



**2003  
WaveRunner  
GP1300R**

**OWNER'S/OPERATOR'S  
MANUAL**

**READ THIS MANUAL  
CAREFULLY BEFORE OPERATION!**

---

**YAMAHA MOTOR CO., LTD.**  
**F1G-F8199-70**



## EC declaration of conformity

E

THE MANUFACTURER:

Yamaha Motor Europe N.V.

P.O.Box 75033; 1117 ZN Schiphol; The Netherlands

HEREBY DECLARES THAT THE

**Yamaha Personal Watercraft,  
type and serial number :  
GP1300R (F1G800101-)**

COMPLIES WITH THE PROVISIONS OF THE

Directive 89/336/EEC relating to electromagnetic compatibility (EMC),

COMPLIES WITH THE PROVISIONS OF THE FOLLOWING  
HARMONIZED STANDARD:

- EN 50082-2

ALSO COMPLIES WITH THE FOLLOWING EUROPEAN STANDARDS,  
NATIONAL STANDARDS AND TECHNICAL PROVISIONS:

- CISPR 12.

Done at Schiphol, (The Netherlands),

On, 2002-12-18

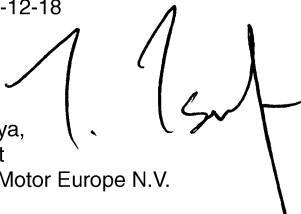

T. Tsuchiya,  
President

Yamaha Motor Europe N.V.

## To the owner/operator

Thank you for choosing a Yamaha watercraft.

This Owner's/Operator's Manual contains information you will need for proper operation, maintenance, and care. A thorough understanding of these simple instructions will help you to obtain maximum enjoyment from your new Yamaha. If you have any questions about the operation or maintenance of your watercraft, please consult a Yamaha dealer.

Because Yamaha has a policy of continuing product improvement, this product may not be exactly as described in this Owner's/Operator's Manual. Specifications are subject to change without notice.

This manual should be considered a permanent part of this watercraft and should remain with it even if the watercraft is subsequently sold.

EJU09900

### Important manual information:

In this manual, information of particular importance is distinguished in the following ways:



The Safety Alert Symbol means **ATTENTION! BECOME ALERT! YOUR SAFETY IS INVOLVED!**

### **!WARNING**

**Failure to follow WARNING instructions could result in severe injury or death to the machine operator, passenger, a bystander, or a person inspecting or repairing the watercraft.**

### **CAUTION:**

**A CAUTION indicates special precautions that must be taken to avoid damage to the watercraft.**

### **NOTE:**

A NOTE provides key information to make procedures easier or clearer.

EJU09910

**WaveRunner GP1300R  
OWNER'S/OPERATOR'S MANUAL  
©2002 by Yamaha Motor Co., Ltd.  
1st Edition, December 2002  
All rights reserved.  
Any reprinting or unauthorized use  
without the written permission of  
Yamaha Motor Co., Ltd.  
is expressly prohibited.  
Printed in USA**



# CONTENTS



## GENERAL AND SAFETY INFORMATION

1



## FEATURES AND FUNCTIONS

2



## OPERATION

3



## MAINTENANCE AND CARE

4



## TROUBLESHOOTING AND EMERGENCY PROCEDURES

5



## APPENDIX

6

READ THIS OWNER'S/OPERATOR'S MANUAL CAREFULLY BEFORE OPERATING YOUR WATERCRAFT.



# GENERAL AND SAFETY INFORMATION



<b>Identification numbers</b> .....	1-1
Primary Identification (PRI-ID) number .....	1-1
Hull Identification Number (HIN) .....	1-1
Engine serial number .....	1-1
<b>Emission control information</b> <b>(For Canada only)</b> .....	1-2
Approval label of Emission control certificate .....	1-2
Manufactured date label .....	1-2
<b>Important labels</b> .....	1-3
Label location .....	1-3
Warning labels .....	1-4
Other labels .....	1-7
<b>Safety information</b> .....	1-9
Limitations on who may operate the watercraft .....	1-9
Cruising limitations .....	1-10
Operation requirements .....	1-11
Recommended equipment .....	1-13
Hazard information .....	1-14
Watercraft characteristics .....	1-14
<b>Safe boating rules</b> .....	1-16
<b>Enjoy your watercraft responsibly</b> .....	1-16



EJU18300

## Identification numbers

Record the Primary Identification (PRI-ID) number, Hull Identification Number (HIN) and engine serial number in the spaces provided for assistance when ordering spare parts from a Yamaha dealer. Also record and keep these ID numbers in a separate place in case your watercraft is stolen.

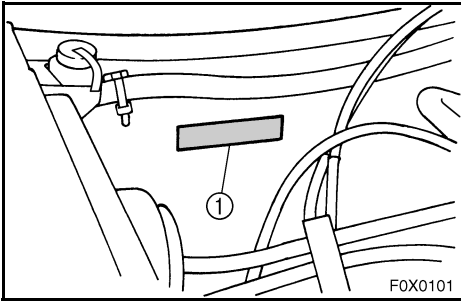

EJU18310

### Primary Identification (PRI-ID) number

MODEL	GP1300-B	PRI-ID	<input type="text"/>
		F1G	<input type="text"/>
YAMAHA MOTOR MANUFACTURING CORPORATION OF AMERICA ASSEMBLED IN U.S.A. FROM AMERICAN AND JAPANESE COMPONENTS. ASSEMBLÉ AUX ÉTATS-UNIS DE PIÈCES AMÉRICAINES ET JAPONAISES.			

F	1	G	-	<input type="text"/>	<input type="text"/>	<input type="text"/>	<input type="text"/>	<input type="text"/>	<input type="text"/>	<input type="text"/>
---	---	---	---	----------------------	----------------------	----------------------	----------------------	----------------------	----------------------	----------------------

The PRI-ID number is stamped on a label ① attached inside the engine compartment.

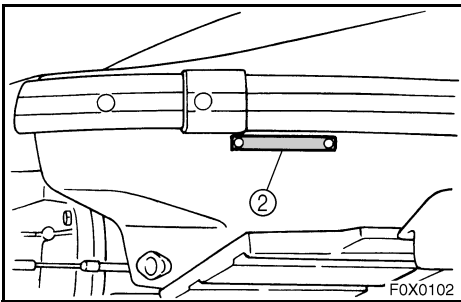

EJU18840

### Hull Identification Number (HIN)

Y	A	M	<input type="text"/>	<input type="text"/>	<input type="text"/>	<input type="text"/>	<input type="text"/>	<input type="text"/>	<input type="text"/>	<input type="text"/>	<input type="text"/>	<input type="text"/>	<input type="text"/>	<input type="text"/>	<input type="text"/>	<input type="text"/>	<input type="text"/>	<input type="text"/>	<input type="text"/>
---	---	---	----------------------	----------------------	----------------------	----------------------	----------------------	----------------------	----------------------	----------------------	----------------------	----------------------	----------------------	----------------------	----------------------	----------------------	----------------------	----------------------	----------------------

The HIN is stamped on a plate ② attached to the hull on the aft, starboard (right) side.

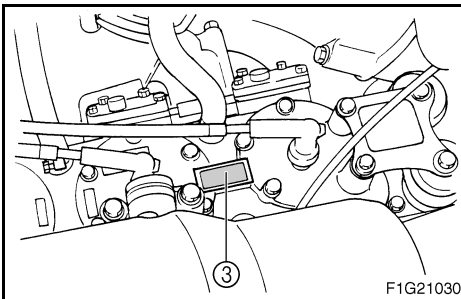

EJU09970

### Engine serial number

<b>YAMAHA</b>									
<input type="text"/>	<input type="text"/>	<input type="text"/>	<input type="text"/>	<input type="text"/>	<input type="text"/>	<input type="text"/>	<input type="text"/>	<input type="text"/>	<input type="text"/>
YAMAHA MOTOR CO., LTD. MADE IN JAPAN PAYS D'ORIGINE JAPON									

The engine serial number is stamped on a label ③ attached to the engine unit.

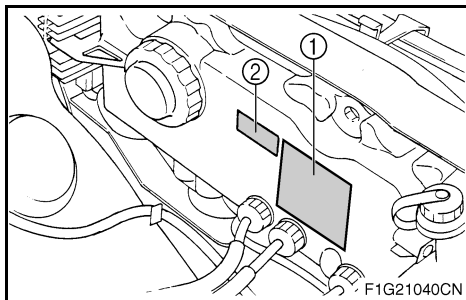

EJU19870

## Emission control information (For Canada only)

This engine conforms to 2003 U.S. Environmental Protection Agency (EPA) regulations for marine SI engines.

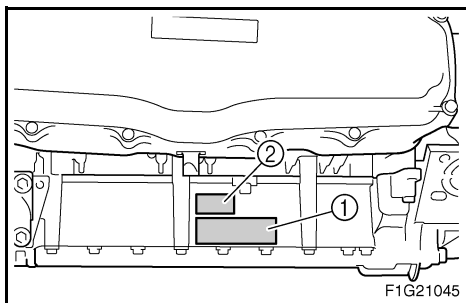

EJU14510

## Approval label of Emission control certificate

This label is attached to the electrical box and the intake side of the crankcase.

### ① Emission control information label

EMISSION CONTROL INFORMATION		CATALYST
ENGINE FAMILY : [.....]		
THIS ENGINE CONFORMS TO 2003 U.S. EPA REGULATIONS FOR MARINE SI ENGINES.		
FELS : [.....] g/kw-hr	SPARK PLUG GAP (mm) : [.....]	
DISPLACEMENT : [.....] cm <sup>3</sup>		TROLLING SPEED : [.....] rpm
ADVERTISED POWER : [.....] kw	FUEL : UNLEADED REGULAR GASOLINE	
ENGINE LUBRICANT : YAMALUBE2W		
INFORMATION ANTIPOLLUTION		CATALYSEUR
CATEGORIE DU MOTEUR : [.....]		
CE MOTEUR EST CONFORME AUX NORMES 2003 EPA E.U. POUR MOTEURS NAUTIQUES SI.		
FELS : [.....] g/kw-hr	BOUGIE-ECARTEMENT (mm) : [.....]	
CYLINDRE : [.....] cm <sup>3</sup>		REGIME EMBRAVE : [.....] RPM
CABRANT : ESSENCE NORMALE SANS PLOMB		
PUISSANCE AFFICHEE : [.....] kw	LUBRIFIANT DU MOTEUR : YAMALUBE 2W	
<b>YAMAHA MOTOR CO.,LTD.</b>		

EJU13900

## Manufactured date label

This label is attached to the electrical box and the intake side of the crankcase.

### ② Manufactured date label

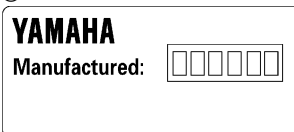



EJU09980

# Important labels

EJU13510

## Label location

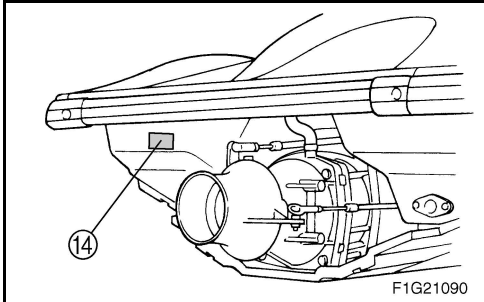
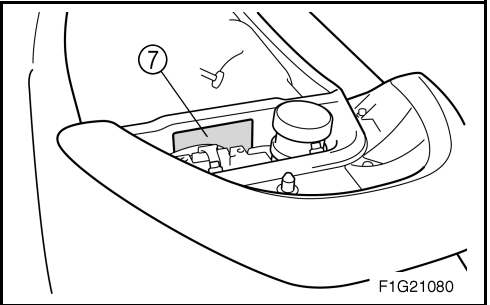
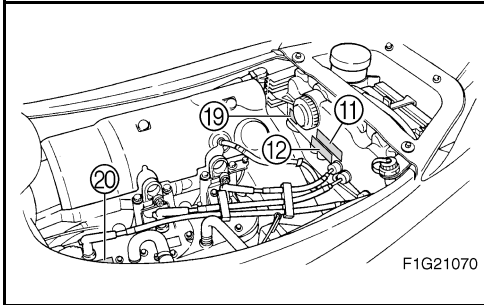
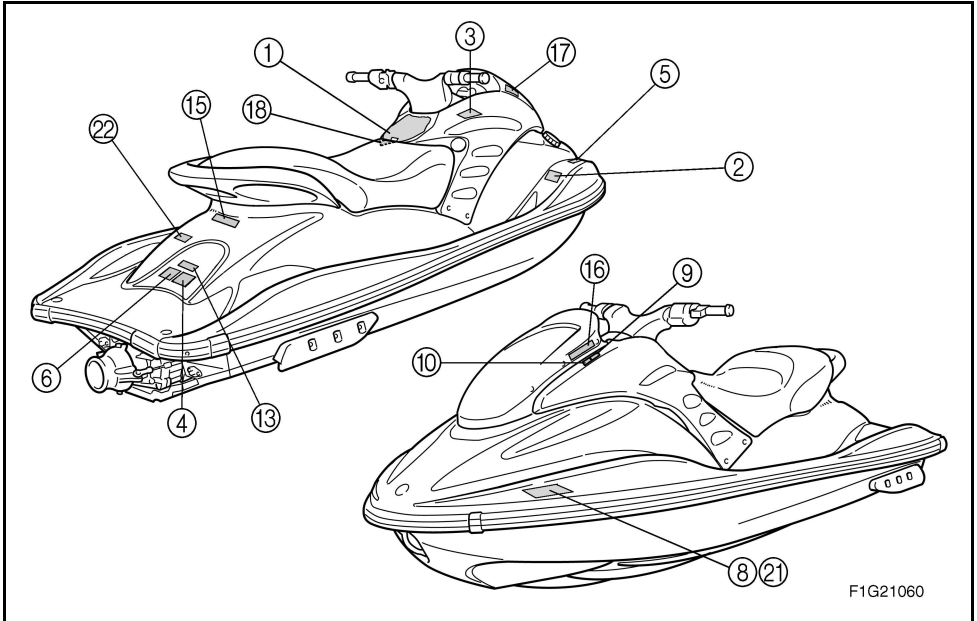



EJU19890

# Warning labels

①

**⚠ Avertissement**

*Afin de limiter les risques de BLESSURES GRAVES, voire MORTELLES:*

**PORTER UN GILET DE SAUVETAGE.** Tout utilisateur doit porter un gilet de sauvetage homologué pour les scooters des mers. *Afin de limiter les risques de BLESSURES GRAVES, voire MORTELLES: RESPECTER SES LIMITES ET ÉVITER LES MANOEUVRES BRUTALES afin de limiter tout risque de perte de contrôle, d'éjection et de collision. Il s'agit d'un véhicule à hautes performances et pas d'un jouet. Des virées brusques au dos, voire de sillages ou de vagues accroît le risque de blessures au dos, voire de paralysie, de blessures au visage et de fractures diverses. Ne jamais sauter des sillages ni des vagues.*

**PORTER DES VÊTEMENTS PROTÉCTEURS.** Le port d'un simple maillot de bain ne constitue pas une protection adéquate contre la puissance de pénétration de l'eau dans le rectum et/ou le vagin. Tout utilisateur doit porter le pantalon d'une tenue de plongée ou tout autre vêtement offrant une protection semblable. (Voir le manuel d'utilisation.) Le port de chaussures, de gants et de lunettes de plongée est recommandé.

**CONNÂTRE LES LOIS DE NAVIGATION.** La Yamaha Motor Co., Ltd. recommande la limite d'âge de pilotage de 16 ans. Vérifier l'âge du pilote ainsi que les exigences quant à l'âge prévues par la législation locale. Il est préférable, et parfois requis par certaines législations, de suivre un cours de sécurité maritime.

**ATTACHER LA LANIÈRE DE L'INTERRUPTEUR D'ARRÊT DU MOTEUR** au poignet et l'éloigner du guidon afin que le moteur se coupe bien en cas de chute. Après utilisation, retirer la lanrière du scooter afin de prévenir toute utilisation par des enfants ou des personnes non-autorisées.

**NE PAS DONNER DES GAZ LORSQUE QUELQU'UN SE TROUVE DERRIÈRE LE VÉHICULE:** Eau et/ou débris projetés par la pompe pourraient causer des blessures graves.

**NE PAS S'APPROCHER DE LA GRILLE D'ADMISSION** lorsque le moteur tourne. Cheveux longs, vêtements amples ou lanières de gilet de sauvetage risquent d'être happés, ce qui pourrait provoquer des blessures, ou même une noyade.

**NE JAMAIS PILOTER APRES AVOIR ABSORBÉ DE L'ALCOOL, DES DROGUES OU CERTAINS MÉDICAMENTS.**

**LIRE ET RESPECTER LES INSTRUCTIONS DONNÉES DANS LE MANUEL D'UTILISATION.**

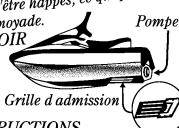
**⚠ WARNING**

**To reduce the risk of SEVERE INJURY or DEATH:**

**WEAR A PERSONAL FLOTATION DEVICE (PFD).** All riders must wear an authority-approved riding, remove cord from PWC to avoid unauthorized use by children or others. PFD that is suitable for personal watercraft (PWC) use.

**WEAR PROTECTIVE CLOTHING.** Severe internal injuries can occur if water is forced into body cavities as a result of falling into water or being near jet thrust nozzle. Normal swimwear does not adequately protect against forceful water entry into rectum or vagina. All riders must wear a wet suit bottom or clothing that provides equivalent protection (See Owner's Manual).

Footwear, gloves, and goggles/glasses are recommended.

**KNOW BOATING LAWS.** Yamaha Motor Co., Ltd. recommends a minimum operator age of 16 years old. Know the operator age and training requirements for your state. A boating safety course is recommended and may be required in your state.

**ATTACH ENGINE SHUT-OFF CORD (LANYARD)** to wrist and keep it free from handlebars so that engine stops if operator falls off. After

**RIDE WITHIN YOUR LIMITS AND AVOID AGGRESSIVE MANEUVERS** to reduce the risk of loss of control, ejection, and collision. This is a high performance boat — not a toy. Sharp turns or jumping wakes or waves can increase the risk of back/spinal injury (paralysis), facial injuries, and broken legs, ankles, and other bones. Do not jump wakes or waves.

**DO NOT APPLY THROTTLE WHEN ANYONE IS AT REAR OF PWC** — turn engine off or keep engine at idle. Water and/or debris exiting jet thrust nozzle can cause severe injury.

**KEEP AWAY FROM INTAKE GRATE** while engine is on. Items such as long hair, loose clothing, or PFD straps can become entangled in moving parts resulting in severe injury or drowning.

**YAMAHA**  
FOX-U41B1-12

**NEVER RIDE AFTER CONSUMING DRUGS OR ALCOHOL**  
**READ AND FOLLOW OWNER'S MANUAL**

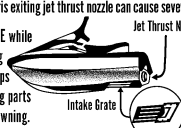

②

## ▲ WARNING

Collisions result in more **INJURIES AND DEATHS** than any other type of accident for personal watercraft (PWC).

### TO AVOID COLLISIONS:

**SCAN CONSTANTLY** for people, objects, and other watercraft. Be alert for conditions that limit your visibility or block your vision of others.

**OPERATE DEFENSIVELY** at safe speeds and keep a safe distance away from people, objects, and other watercraft.

- Do not follow directly behind PWCs or other boats.
- Do not go near others to spray or splash them with water.
- Avoid sharp turns or other maneuvers that make it hard for others to avoid you or understand where you are going.
- Avoid areas with submerged objects or shallow water.

**TAKE EARLY ACTION** to avoid collisions. Remember, PWCs and other boats do not have brakes.

**DO NOT RELEASE THROTTLE WHEN TRYING TO STEER** away from objects — you need throttle to steer. Always check throttle and steering controls for proper operation before starting PWC. Follow navigation rules and state/province and local laws that apply to PWCs. See Owner's Manual for more information.

YAMAHA

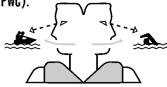

③

## ▲ AVERTISSEMENT

Les collisions sont la cause principale des **BLESSURES ET DÉCÈS** d'utilisateurs de scooter des mers.

### POUR ÉVITER LES COLLISIONS:

**ÊTRE CONSTANTMENT à l'affût** de personnes, d'objets et d'autres bateaux. Être conscient des conditions limitant sa visibilité ou celle des autres embarcations.

**PILOTER AVEC PRUDENCE** à des vitesses raisonnables et garder une distance de sécurité entre le scooter et toute personne, objet et embarcation.

• Ne pas suivre une autre embarcation de trop près.

• Ne pas se rapprocher d'autrui en vue de l'éclabousser.

• Éviter les virages brusques ou toute manœuvre qui risque de mettre un autre pilote en danger ou qui l'empêche de pouvoir déterminer clairement la direction que l'on prend.

• Éviter les endroits où flottent des objets et les eaux peu profondes.

**REAGIR RAPIDEMENT** en vue d'éviter les collisions. Garder à l'esprit que les bateaux n'ont pas de freins.

**NE PAS LÂCHER LES GAZ LORSQUE L'ON ESSAIE DE S'ÉLOIGNER** d'objets — une poussée est nécessaire à la direction du scooter des mers. Toujours s'assurer avant le départ que l'accélérateur et la direction fonctionnent correctement.

Suivre les lois de navigation ainsi que les législations nationales, provinciales et locales concernant les scooters des mers. Voir le manuel d'utilisation pour plus d'informations.

YAMAHA

FOV-U41B2-10



④

## ▲ WARNING

- Severe internal injuries can occur if water is forced into body cavities as a result of being near jet thrust nozzle.
- Wear a wetsuit bottom or clothing that provides equivalent protection.
- Do not board PWC if operator is applying throttle.

## ▲ AVERTISSEMENT

- Le choc infligé par la pénétration forcée d'eau dans les orifices corporels lors du contact avec le jet de la pompe risque de provoquer des lésions graves.
- Porter le pantalon d'une tenue de plongée ou tout autre vêtement offrant une protection semblable.
- Ne pas embarquer lorsque le pilote donne des gaz.

(FOW-U41E2-50)

⑤

## ▲ WARNING

Gasoline is highly flammable and explosive. A fire or explosion could cause severe injury or death. Shut engine off. Refuel in well ventilated area away from flames or sparks. Do not smoke. Avoid spilling gasoline. Wipe up spilled gasoline immediately.

Remove all seats and front storage compartment to ventilate fuel vapors from engine compartment before starting engine. Do not start engine if there is a fuel leak or a loose electrical connection.

REGULAR UNLEADED GASOLINE ONLY

## ▲ AVERTISSEMENT

L'essence est très inflammable et explosive. Un incendie ou une explosion risquent de provoquer des blessures graves, voire mortelles. Couper le moteur. Faire le plein dans un endroit bien aéré et éloigné de toute flamme ou étincelle. Ne pas fumer. Éviter de renverser de l'essence. Essayer immédiatement toute coulure d'essence. Déposer les selles et le compartiment de rangement avant pour évacuer les vapeurs d'essence du compartiment du moteur avant de mettre le moteur en marche. Ne jamais mettre le moteur en marche en cas de fuite d'essence ou si un branchement électrique est desserré.

ESSENCE NORMALE SANS PLOMB UNIQUEMENT

FOV-U415B-00





⑥

**⚠ WARNING**

Do not use cleat or grips to lift PWC. PWC could fall, which could result in severe injury.

**⚠ AVERTISSEMENT**

Ne pas soulever le scooter à l'aide du taquet ou des poignées. Le scooter pourrait tomber et provoquer des blessures graves.

(FOV-U41E2-50)

⑦

**⚠ WARNING**

Be sure to connect breather hose to battery. Fire or explosion could result if not connected properly.

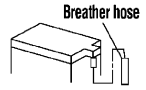
**⚠ AVERTISSEMENT**

Bien veiller à brancher la durit de mise à l'air à la batterie. Un mauvais branchement risque d'être à l'origine d'un incendie ou d'une explosion.

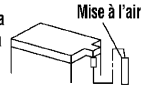

YAMAHA

FOV-U41DB-11

⑧ (For Europe only)

**⚠ AVERTISSEMENT**

APPLICABLE POUR LA FRANCE SEULEMENT

- En France : permis de conduire et immatriculation obligatoire.
- Navigation en mer autorisée entre 300 mètres et 1 mille nautique.
- Entre 0 et 300 mètres, se référer aux instructions nautiques locales affichées.  
Sinon, règle générale : vitesse maxi 5 nœuds (9Km/h) dans cette zone.
- Utiliser les chenaux obligatoires de sortie lorsqu'ils existent.
- Respecter les règles de priorité.
- Gilet de sauvetage obligatoire-Fusée et bout de remorquage à bord.
- Ne jamais conduire sous l'influence de l'alcool ou de drogues.
- Consulter la météo avant de sortir en mer.
- Une conduite responsable et un contrôle quotidien de votre machine suivant le manuel d'entretien YAMAHA seront garants de votre sécurité.

YAMAHA

GJ-U41E6-00

⑨

**⚠ WARNING**

THIS PWC IS EQUIPPED WITH A CATALYTIC CONVERTER.

To reduce risk of severe burn injuries:

- Do not touch any muffler surfaces in engine compartment after running engine. Catalytic converter gets very hot.
- Do not start engine on land if anyone is behind watercraft. Steam and hot water can spurt from exhaust outlet.
- Return to shore at low speed if overheat warning indicator and buzzer come on. If you ignore these signals, engine will stop running and cannot be restarted until exhaust system cools down.
- Do not run engine over 4,000 r/min on land.

YAMAHA

FOV-U418W-00

⑩

**⚠ AVERTISSEMENT**

CE SCOOTER EST ÉQUIPÉ D'UN CATALYSEUR

Afin d'éviter le risque de brûlures graves:

- Ne jamais toucher une partie quelconque du silencieux pendant ou après l'utilisation du moteur. Le catalyseur devient en effet très chaud.
- Ne pas mettre le moteur en marche lorsque quelqu'un se trouve derrière le scooter alors que celui-ci est hors de l'eau. De l'eau et de la vapeur chaudes pourraient gicler de l'échappement.
- Retourner au rivage à vitesse réduite si le témoin d'avertissement de surchauffe s'allume ou si le ronfleur retentit. En cas de non-respect de cette consigne, le moteur se coupe et ne pourra être remis en marche qu'une fois le circuit d'échappement refroidi.
- Ne pas faire tourner le moteur à plus de 4,000 tr/min hors de l'eau.

YAMAHA

FOV-U418W-10



⑪

**WARNING**

Do not touch or remove electrical parts when starting or running the engine.

YAMAHA

6R7-83623-40

⑫

**AVERTISSEMENT**

Ne pas toucher ou retirer les pièces électriques lors du démarrage ou de la marche du moteur.

YAMAHA

6R7-83623-50

EJU19900

**Other labels**

⑬

**RATED PERSON CAPACITY: 2**  
**MAXIMUM LOAD: 160 kg (353 lb)**  
**CAPACITÉ MAXIMALE: 2 personnes**  
**CHARGE MAXIMALE: 160 kg (353 lb)**

(F0W-U41E2-50)

⑭

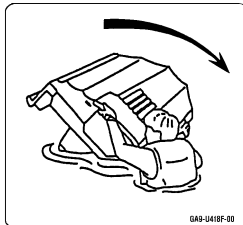

GAB-U41BF-00

⑮

**FIRE EXTINGUISHER**  
**CONTAINER**  
**COMPARTIMENT**  
**DE L'EXTINCTEUR**

F0P-U41F5-10

⑯

**VISOR**

Keep gasoline, oil, solvents, and alkaline or acid cleaners away from visor. Damage may occur. For cleaning, use neutral detergent.

YAMAHA

FOX-U41FD-00

⑰

**VISIÈRE**

Éviter d'enduire la visière d'essence, d'huile, de dissolvant ou de produits de nettoyage alcalins ou acides.  
 Celle-ci risque d'être abîmée. Nettoyer avec un détergent neutre.

YAMAHA

FOX-U41FD-10



18

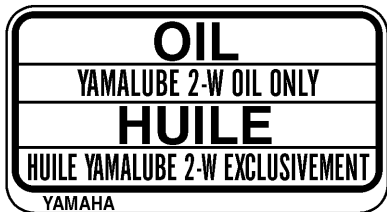

FOV-U41FB-10

19 (For Europe only)

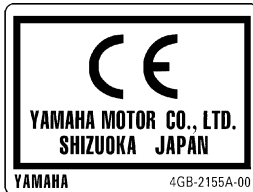

20





(66V-42791-00)

21 (For Canada only)



GJ3-U419E-00

22 (For Canada only)

 Fisheries and Oceans Canada Coast Guard		Pêches et Océans Canada Garde côtière			
<b>BUILDER - CONSTRUCTEUR</b>  YAMAHA MOTOR CANADA (YAM) LTD.		<b>MODEL - MODELE</b>  WAVE RUNNER GP1300 GP1300-B			
THE MANUFACTURER CERTIFIES THAT THIS PRODUCT COMPLIES WITH THE CONSTRUCTION STANDARDS FOR SMALL VESSELS.		LE FABRICANT CERTIFIE QUE CE PRODUIT EST CONFORME AUX NORMES DE CONSTRUCTION DES PETITS BATEAUX.			
NO. - no					



EJU09990



## Safety information

The safe use and operation of this watercraft is dependent upon the use of proper riding techniques, as well as upon the common sense, good judgment, and expertise of the operator. Before using this watercraft, make sure that its use is permitted under local laws, bylaws and regulations and always operate the watercraft in full conformity with any requirements and limitations imposed. Every operator should know the following requirements before riding the watercraft.

- Before operating the watercraft, read this Owner's/Operator's Manual, the Riding Practice Guide, and all warning and caution labels on the watercraft. These materials should give you an understanding of the watercraft and its operation.
- Never allow anyone to operate this watercraft until they too have read this Owner's/Operator's Manual, the Riding Practice Guide and all warning and caution labels.

EJU10000

## Limitations on who may operate the watercraft

- Yamaha recommends a minimum operator age of 16 years old. Adults must supervise use by minors. Know your local operator age and training requirements.



- This watercraft is designed to carry the operator and one passenger. Never exceed the maximum load limit or allow more than 2 persons to ride the watercraft at one time.

Maximum load: 160 kg (353 lb)  
Load is the total weight of cargo,  
operator and passenger.

- Do not operate the watercraft with a passenger on board until you have considerable practice and experience riding alone. Operating the watercraft with a passenger requires more skill. Take the time to become accustomed to the handling characteristics of the watercraft before trying any difficult maneuvers.



EJU10010

## Cruising limitations

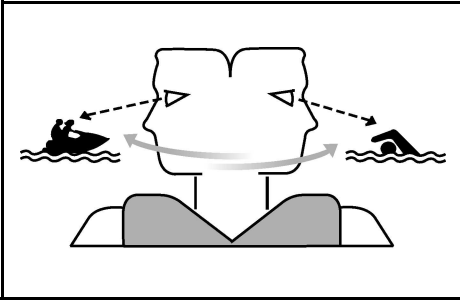

- Scan constantly for people, objects, and other watercraft. Be alert for conditions that limit your visibility or block your vision of others.
- Operate defensively at safe speeds and keep a safe distance away from people, objects, and other watercraft.
- Do not follow directly behind watercraft or other boats.
- Do not go near others to spray or splash them with water.
- Avoid sharp turns or other maneuvers that make it hard for others to avoid you or understand where you are going.
- Avoid areas with submerged objects or shallow water.
- Ride within your limits and avoid aggressive maneuvers to reduce the risk of loss of control, ejection, and collision.
- This is a high performance boat—not a toy. Sharp turns or jumping wakes or waves can increase the risk of back/spinal injury (paralysis), facial injuries, and broken legs, ankles and other bones. Do not jump wakes or waves.

- Do not operate the watercraft in rough water, bad weather or when visibility is poor; this may lead to an accident causing injury or death. Be alert to the possibility of adverse weather. Take note of weather forecasts and the prevailing weather conditions before setting out on your watercraft.
- As with any water sport, you should not ride your watercraft without someone else near by. If you ride further than swimming distance from shore, you should ride by another boat or watercraft, but make sure you stay a safe distance away. It's good common sense!

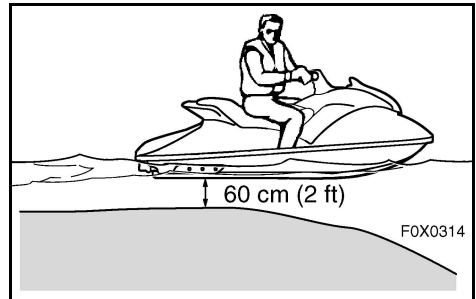

- Never operate in water that is less than 60 cm (2 ft) deep, otherwise you increase your chance of hitting a submerged object, which could result in injury.



- This watercraft is not equipped with lighting required for night operation. Do not operate the watercraft after sunset or before dawn, otherwise you increase the risk of colliding with another boat, which could result in severe injury or death.

EJU10020

## Operation requirements

- All riders must wear an authority-approved PFD that is suitable for personal watercraft use.
- Wear protective clothing. Severe internal injuries can occur if water is forced into body cavities as a result of falling into water or being near the jet thrust nozzle. Normal swimwear does not adequately protect against forceful water entry into rectum or vagina. All riders must wear a wetsuit bottom or clothing that provides equivalent protection. Such clothing includes thick, tightly woven, sturdy and snug-fitting apparel such as denim, but does not include spandex or similar fabrics, like those used in bicycle shorts.

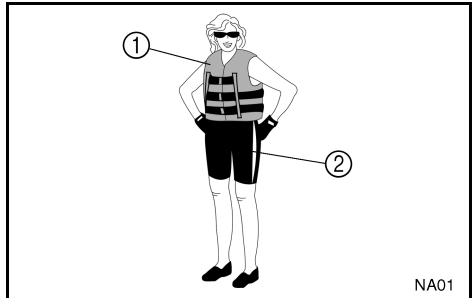

① Authority-approved PFD

② Wetsuit bottom

- Eye protection is recommended to keep wind, water, and glare from the sun out of your eyes while you operate your watercraft. Restraining straps for eyewear are made which are designed to float should your eyewear fall in the water. Footwear and gloves are recommended.



- You must decide whether to wear a helmet while you ride for recreation. You should know that a helmet could help protect you in certain kinds of accidents and that it could injure you in others.

A helmet is designed to provide some head protection. Although helmets cannot protect against all foreseeable impacts, a helmet might reduce your injuries in a collision with a boat or other obstacle.

A helmet may have potential safety hazards, as well. Falling into the water could risk the chance of the helmet catching water, commonly known as “bucketing,” and the resulting strain on your neck could cause choking, severe and permanent neck injuries, or death. A helmet could also increase the risk of an accident if it reduces your vision or hearing, or if it distracts you or increases your fatigue.

How should you decide if a helmet’s potential safety benefits outweigh its potential risks for you? Consider your particular riding conditions. Consider factors such as your riding environment and your riding style and ability. Also consider the likelihood of traffic congestion, and the water surface conditions. If you decide to wear a helmet based upon your riding circumstances, choose one carefully. Look for a helmet designed for personal watercraft use, if possible. If you will be engaging in closed-course competition, follow the helmet requirements of the sanctioning organization.



- NEVER operate the watercraft after consuming alcohol or taking other drugs.
- For reasons of safety and proper care of the watercraft, always perform the pre-operation checks listed on page 3-6 before operating the watercraft.
- The operator and passenger should always keep both feet in the footwell when the watercraft is in motion. Lifting your feet increases your chances of losing your balance, and your feet being hit by objects outside the watercraft. Do not give a ride to a child whose feet cannot reach the floor of the footwell.

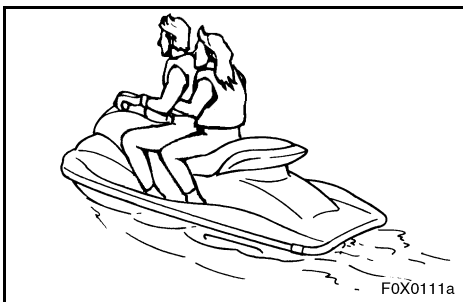

- Passenger should firmly hold on to the operator.
- Always consult your doctor on whether it is safe for you to ride this watercraft if you are pregnant or in poor health.



- Do not attempt to modify this watercraft! Modifications to your watercraft may reduce safety and reliability, and render the watercraft unsafe or illegal for use.

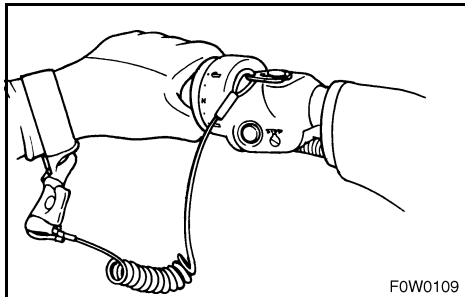

- Attach the engine shut-off cord (lanyard) to wrist and keep it free from the handlebars so that the engine stops if the operator falls off. After riding, remove the engine shut-off cord from the watercraft to avoid accidental starting or unauthorized use by children or others.
- Scan carefully for swimmers and stay away from swimming areas. Swimmers are hard to see and you could accidentally hit someone in the water.
- Avoid being hit by another boat! You should always take the responsibility to watch for traffic; other boaters may not be watching for you. If they do not see you, or you maneuver more quickly than other boaters expect, you risk a collision.
- Maintain a safe distance from other boats or watercraft, and also watch for boats' ski ropes or fishing lines. Obey the "Safe boating rules" and be sure to check behind you before making a turn. (See Safe boating rules on page 1-16.)

EJU13820

## Recommended equipment

The following items should be carried on board your watercraft:

- Sound-signaling device  
You should carry a whistle or other sound-signaling device that can be used to signal other boats.
- Visual distress signals  
It is recommended that an authority-approved pyrotechnic device be stored in a waterproof container on your watercraft. A mirror can also be used as an emergency signal. Contact your Yamaha dealer for more information.
- Watch  
A watch is helpful so you will know how long you have been operating.
- Towline  
A towline can be used to tow a disabled watercraft in an emergency.





EJU20020

## Hazard information

- Never start the engine or let it run for any length of time in an enclosed area. Exhaust fumes contain carbon monoxide, a colorless, odorless gas that may cause loss of consciousness and death within a short time. Always operate the watercraft in an open area.
- Do not start engine on land until everyone is away from stern. Hot water and steam spurting from exhaust outlet can cause serious burns.
- Hot muffler surfaces can cause serious burns. Do not touch any muffler surface during or after engine operation. Catalytic converter gets hotter after engine stops.

EJU20030

## Watercraft characteristics

- Jet thrust turns the watercraft. Releasing the throttle lever completely produces only minimum thrust. If you are traveling at speeds above trolling, you will have rapidly decreasing ability to steer without throttle. This model has the Yamaha Engine Management System (YEMS) that includes an Off-Throttle Steering (OTS) system. It will activate at planing speeds should you attempt to steer the watercraft after releasing the throttle lever. The OTS system assists in turning by continuing to supply some thrust while the watercraft is decelerating, but you can turn more sharply if you apply throttle while turning the handlebars. The OTS system does not function below planing speeds or when the engine is off. Once the engine slows down, the watercraft will no longer turn in response to handlebar input until you apply throttle again or you reach trolling speed. Practice turning in an open area without obstructions until you have a good feel for this maneuver.
- This watercraft is water-jet propelled. The jet pump is directly connected to the engine. This means that jet thrust will produce some movement whenever the engine is running. There is no “neutral” position.



- Keep away from the intake grate ① while the engine is on. Items such as long hair, loose clothing, or PFD straps can become entangled in moving parts resulting in severe injury or drowning.
- Never insert any object into the jet thrust nozzle ② while the engine is running. Severe injury or death could result from coming in contact with the rotating parts of the jet pump.

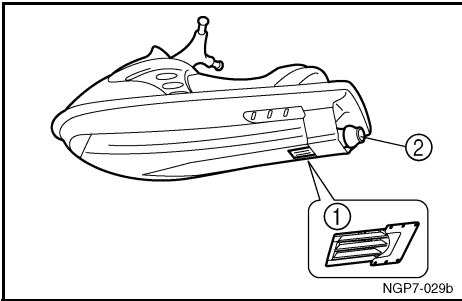

- Stop the engine and remove the clip ③ from the engine shut-off switch ④ before removing any debris or weeds, which may have collected around the jet intake.

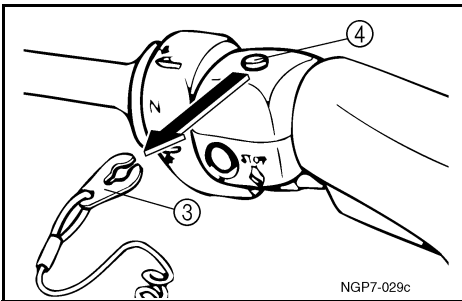



## Safe boating rules

Your Yamaha watercraft is legally considered a powerboat. Operation of the watercraft must be in accordance with the rules and regulations governing the waterway on which it is used.

## Enjoy your watercraft responsibly

You share the areas you enjoy when riding your watercraft with others and with nature. So your enjoyment includes a responsibility to treat these other people, and the lands, waters, and wildlife with respect and courtesy.

Whenever and wherever you ride, think of yourself as the guest of those around you. Remember, for example, that the sound of your watercraft may be music to you, but it could be just noise to others. And the exciting splash of your wake can make waves others won't enjoy. Avoid riding close to shoreline homes and waterfowl nesting areas or other wildlife areas, and keep a respectful distance from fishermen, other boats, swimmers, and populated beaches. When travel in areas like these is unavoidable, ride slowly and obey all laws.

Remember that pollution can be harmful to the environment. Do not refuel or add oil where a spill could cause damage to nature. Remove your watercraft from the water and move it away from the shoreline before refueling. And keep your surroundings pleasant for the people and wildlife that share the waterways: don't litter!

When you ride responsibly, with respect and courtesy for others, you help ensure that our waterways stay open for the enjoyment of a variety of recreational opportunities.



---

**-MEMO-**

# FEATURES AND FUNCTIONS



**Location of main components** .....2-1

## Operation of controls and other

<b>functions</b> .....	2-5
Seat .....	2-5
Hood .....	2-6
Fuel tank filler cap .....	2-6
Oil tank filler cap .....	2-6
Engine stop switch .....	2-7
Engine shut-off switch .....	2-7
Throttle lever .....	2-7
Start switch .....	2-8
Cooling water pilot outlet .....	2-8
Steering system .....	2-9
Quick Shift Trim System (QSTS) selector .....	2-10
Handgrip .....	2-11
Engine overheat warning system .....	2-12
Exhaust temperature warning system .....	2-13
Yamaha Engine Management System (YEMS) .....	2-14
Multifunction information center .....	2-15
Tachometer .....	2-16
Speedometer .....	2-16
Fuel meter .....	2-16
Hour meter/Voltmeter .....	2-17
Fuel warning indicator .....	2-17
Oil warning indicator .....	2-18
Check engine warning indicator .....	2-18
Engine overheat warning indicator .....	2-19
Exhaust temperature warning indicator .....	2-19
Storage compartments .....	2-20
Yamaha Adjustable Sponson (Y.A.S.) .....	2-21



EJU10080

## Location of main components

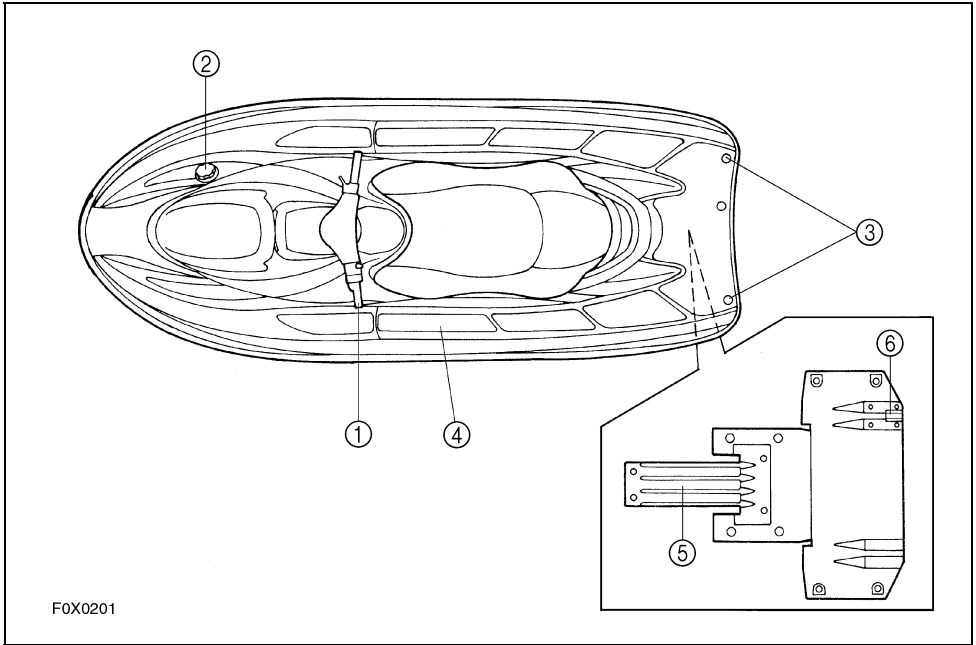

F0X0201

- ① **Handlebars**  
Use to control direction.
- ② **Fuel tank filler cap**
- ③ **Rope hole**
- ④ **Footwell**  
Use to place feet for balance.
- ⑤ **Intake grate**  
Prevents debris from getting into the jet pump.
- ⑥ **Speed sensor**

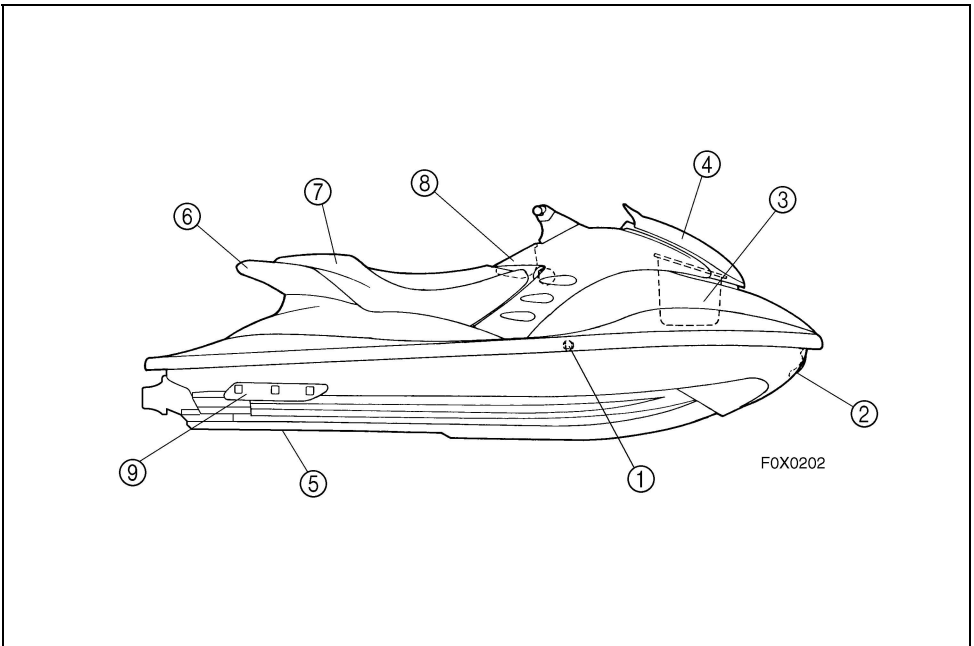

- ① **Cooling water pilot outlet**  
Use to verify cooling water flow.
- ② **Bow eye**  
Use to attach rope for transporting, mooring or towing the watercraft in an emergency.
- ③ **Front storage compartment**
- ④ **Hood**
- ⑤ **Jet intake**
- ⑥ **Handgrip**
- ⑦ **Seat**
- ⑧ **Glove compartment**
- ⑨ **Yamaha Adjustable Sponson (Y.A.S.)**

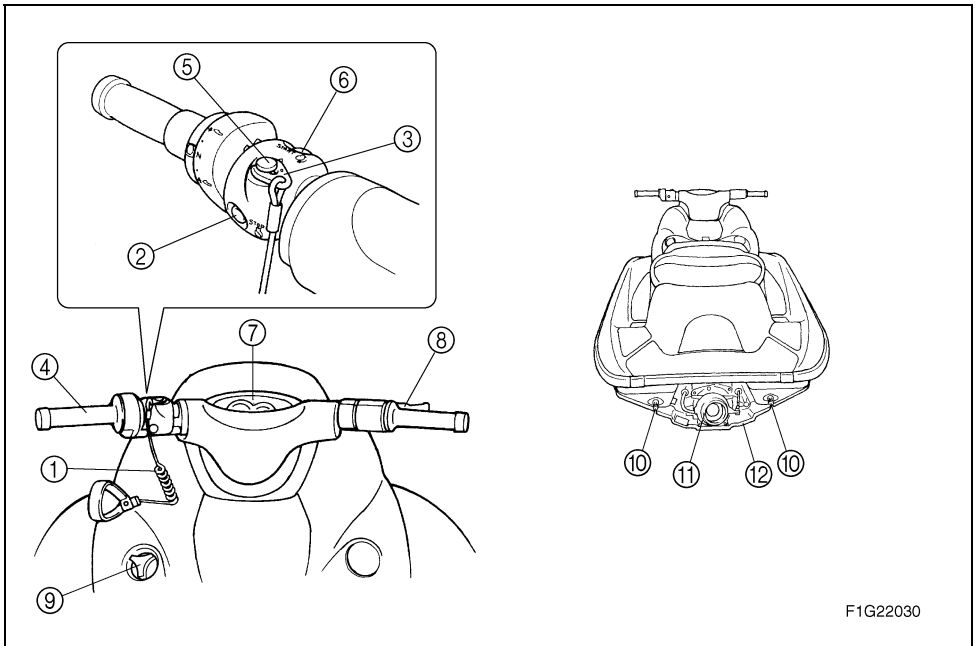

F1G22030

- ① **Engine shut-off cord (lanyard)**  
Attach to wrist so that the engine stops if the operator falls off the watercraft.
- ② **Engine stop switch**  
Push to stop the engine normally.
- ③ **Clip**  
Insert into the engine shut-off switch to enable starting of the engine.  
Remove to stop the engine or prevent accidental starting of the engine or unauthorized use of the watercraft.
- ④ **Quick Shift Trim System (QSTS) selector**  
Use to select the trim angle of the watercraft.
- ⑤ **Engine shut-off switch**  
Remove the clip to stop the engine and disable it from starting.
- ⑥ **Start switch**  
Push to start the engine.
- ⑦ **Multifunction information center**  
Use to check watercraft operation.
- ⑧ **Throttle lever**  
Use to accelerate and decelerate.
- ⑨ **Oil tank filler cap**
- ⑩ **Stern drain plugs**  
Use to drain water in the bilge when the watercraft is on dry land.
- ⑪ **Jet thrust nozzle**  
Changes the direction of jet thrust according to handlebar position.
- ⑫ **Ride plate**



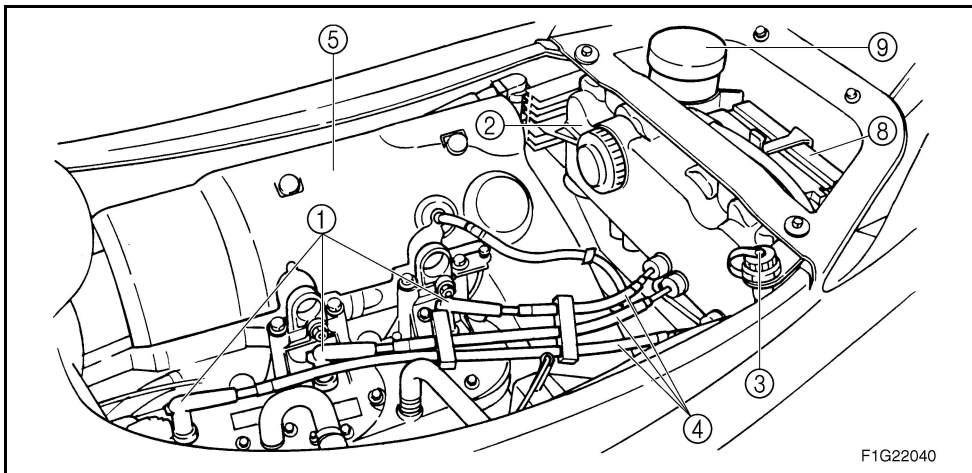

F1G22040

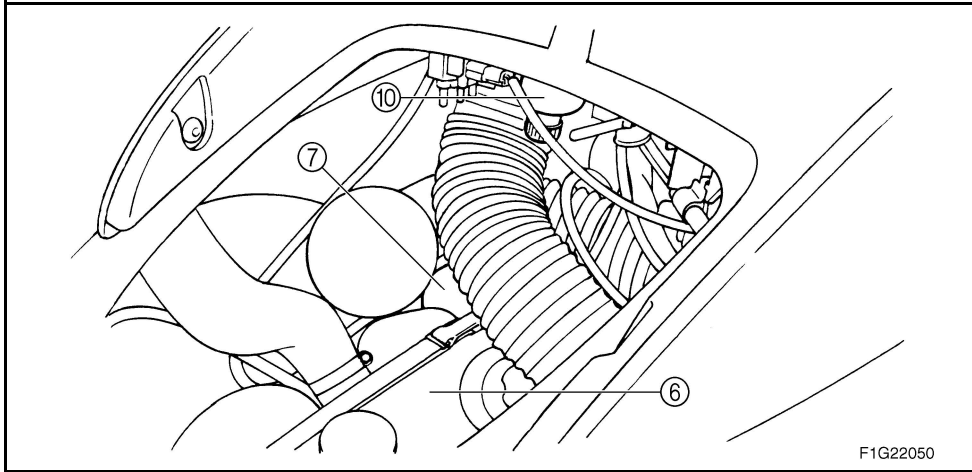

F1G22050

- ① **Spark plugs/Spark plug caps**
- ② **Electrical box**  
Protects electrical components from water.
- ③ **Flush hose connector**  
Use to flush the engine cooling water passages.
- ④ **Spark plug lead**
- ⑤ **Muffler**
- ⑥ **Fuel tank**
- ⑦ **Oil tank**
- ⑧ **Battery**
- ⑨ **Fire extinguisher container**
- ⑩ **Water separator**



EJU10090

## Operation of controls and other functions

EJU10100

### Seat

There is a seat latch ① at the rear of the seat to remove the seat.

#### To remove the seat:

Pull the seat latch up, and then pull the seat off.

#### To install the seat:

Insert the projection on the front of the seat into the stay on the deck, and then push the rear of the seat down to lock it in place securely.

#### NOTE:

Make sure that the seat is properly secured before operating the watercraft.

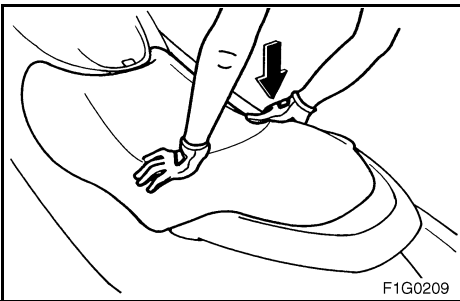
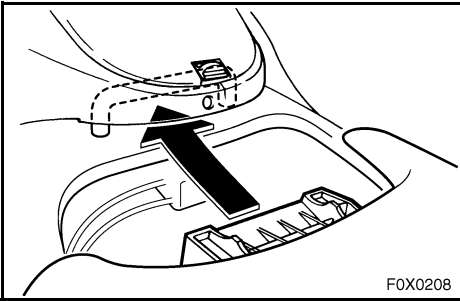
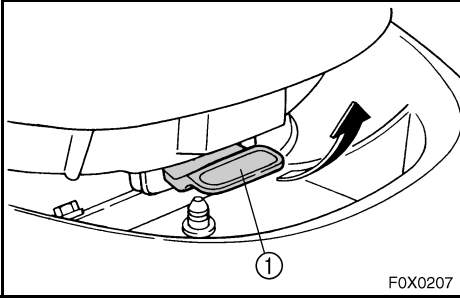

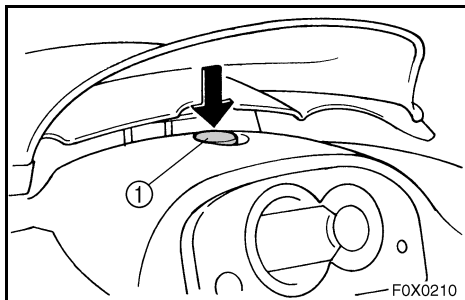

EJU10110

**Hood**

To open the hood, push the latch ① down, and then lift the hood up.

To close the hood, push the hood down to lock it in place.

**NOTE:** \_\_\_\_\_  
Make sure that the hood is properly secured before operating the watercraft.

---

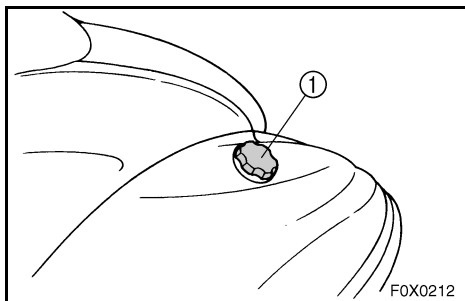
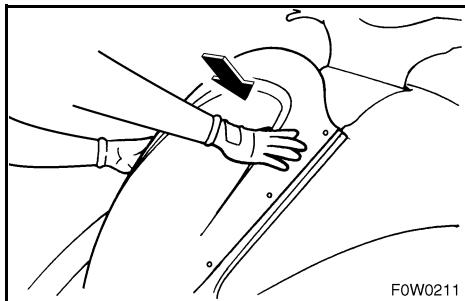

EJU10120

**Fuel tank filler cap**

To remove the fuel tank filler cap ①, turn it counterclockwise.

**NOTE:** \_\_\_\_\_  
Make sure that the fuel tank filler cap is properly secured before operating the watercraft.

---

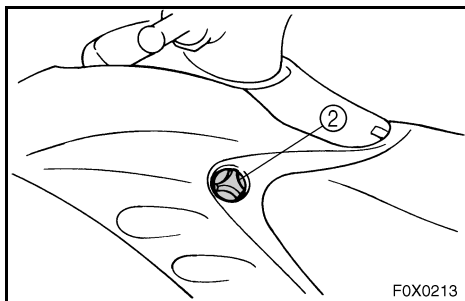

EJU10130

**Oil tank filler cap**

To remove the oil tank filler cap ②, turn it counterclockwise.

**NOTE:** \_\_\_\_\_  
Make sure that the oil tank filler cap is properly secured before operating the watercraft.

---

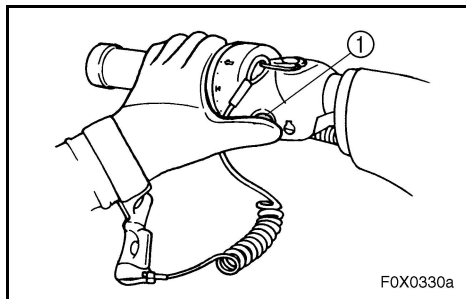

EJU10150

## Engine stop switch

Push this switch ① (red button) to stop the engine normally.

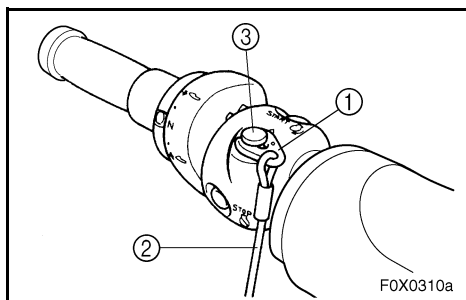

EJU10160

## Engine shut-off switch

Insert the clip ①, on the end of the engine shut-off cord ②, under the engine shut-off switch ③ (black button). The engine will stop automatically when the clip is removed from the switch, such as if the operator falls off the watercraft.

### **⚠WARNING**

- Always attach the engine shut-off cord to your wrist and the clip to the engine shut-off switch **BEFORE** starting the engine.
- To prevent accidental starting of the engine or unauthorized use by children or others, always remove the clip from the shut-off switch when the engine is not running.

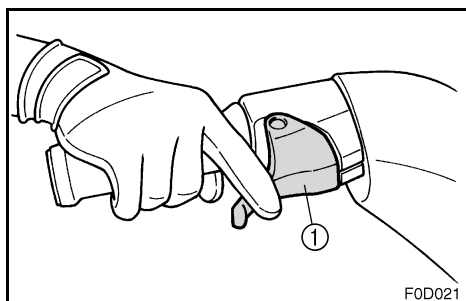
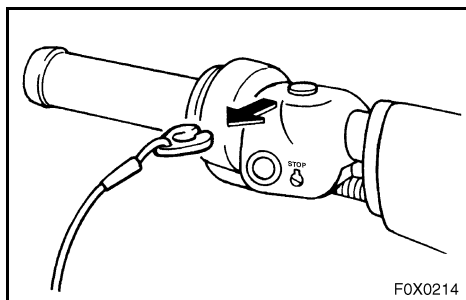

EJU10180

## Throttle lever

Squeeze the throttle lever ① to increase engine speed.

Release the throttle lever to decrease engine speed or to return it to the idle position.

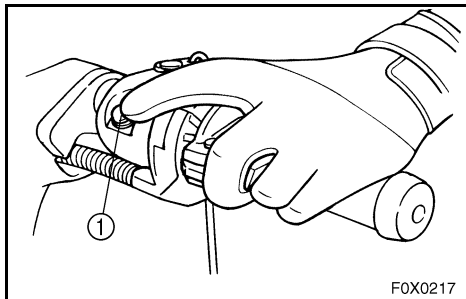

EJU18610

### Start switch

Push the start switch ① (green button) to start the engine.

**NOTE:** \_\_\_\_\_  
The engine will not start when the clip is removed from the engine shut-off switch or if the throttle lever is squeezed.

---

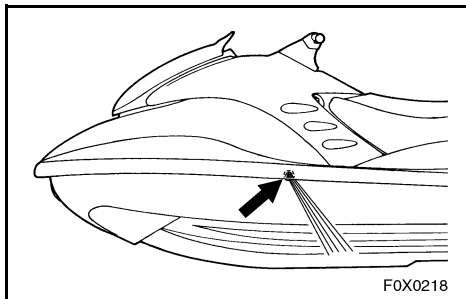

EJU10201

### Cooling water pilot outlet

This watercraft is equipped with cooling water pilot outlets.

When the engine is running, cooling water is circulated in the engine, and then it is discharged from the pilot outlets.

To check for proper operation of the cooling system, check that water is being discharged from the pilot outlets. If water is not being discharged from the outlets, cooling water may not be circulating in the engine. When this occurs, stop the engine and check for the cause. (See pages 2-12 and 5-4 for further instructions.)

**NOTE:** \_\_\_\_\_  
If the cooling water passages are dry, it will take about 20 seconds for the water to reach the outlet after the engine is started.

---



EJU19950

## Steering system

Your watercraft can be steered by turning the handlebars ① in the direction you wish to travel.

When the handlebars are turned, the angle of the jet thrust nozzle ② is changed and the direction of the watercraft is changed accordingly. Since the strength of the jet thrust determines the speed and degree of a turn, throttle must always be applied when attempting a turn, except at trolling speed.

This model has the Yamaha Engine Management System (YEMS) that includes an Off-Throttle Steering (OTS) system. It will activate at planing speeds should you attempt to steer the watercraft after releasing the throttle lever. The OTS system assists in turning by continuing to supply some thrust while the watercraft is decelerating, but you can turn more sharply if you apply throttle while turning the handlebars. The OTS system does not function below planing speeds or when the engine is off. Once the engine slows down, the watercraft will no longer turn in response to handlebar input until you apply throttle again or you reach trolling speed.

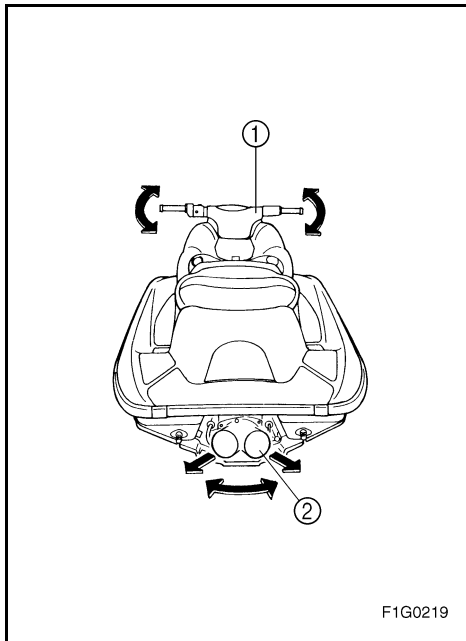



EJU10220

## Quick Shift Trim System (QSTS) selector

The QSTS selector ① is located at the left handlebar grip and is used to adjust the trim angle of the watercraft.

Operating the QSTS selector changes the angle of the jet thrust nozzle vertically. This changes the trim angle of the watercraft.

There are 5 positions: 2 bow down positions ① and ②, neutral “N,” and 2 bow up positions ③ and ④.

### To change the trim angle:

1. Reduce engine speed to 3,000 r/min or less.
2. Squeeze the shift lock lever ②, and then turn the QSTS selector to the desired position.
3. Release the shift lock lever to lock the QSTS selector.

### CAUTION:

Do not turn the QSTS selector while operating the watercraft at full throttle, otherwise damage could occur to the QSTS.

The neutral “N” position will provide good performance for most operating conditions.

To enhance particular types of performance, select bow down or bow up.

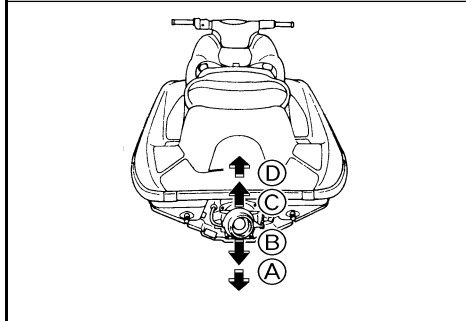
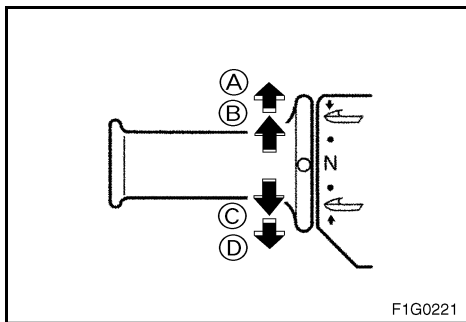
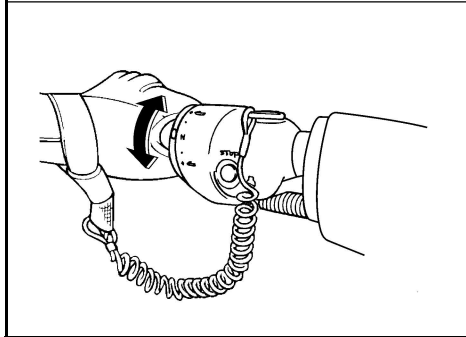
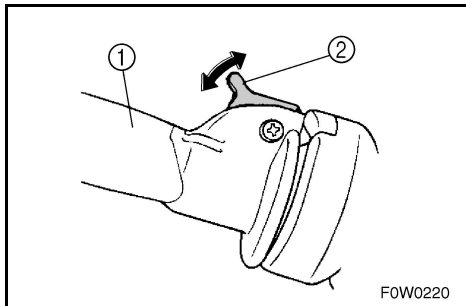

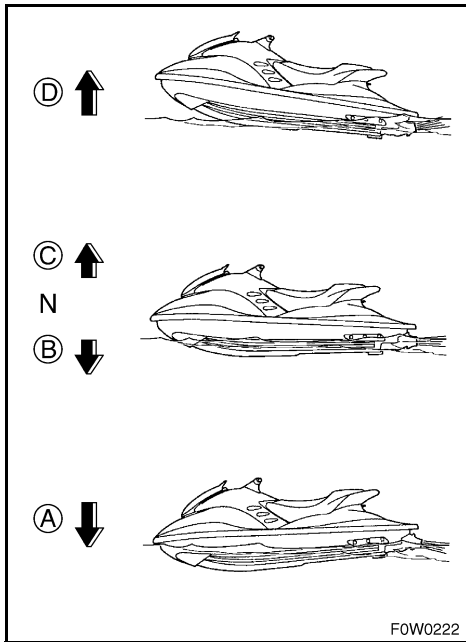

EJU10230

### Bow down

Turn the grip to ① or ② and the bow will go down while the watercraft is on plane.

Bow down puts more of the bow in the water. This gives the watercraft more “hook,” which enhances turning performance. This position will also help the watercraft get up on plane more quickly.

At higher speeds, however, the watercraft will have greater tendency to “bow steer” and follow waves and wakes in the water. Fuel economy and maximum speed are also reduced.

EJU10240

### Bow up

Turn the grip to ③ or ④ and the bow will go up while the watercraft is on plane.

Bow up puts less of the bow in the water. There is less water resistance, so straight-ahead acceleration when on plane and top speed are enhanced.

In some conditions, however, the watercraft may tend to “porpoise” (hop in the water). If the watercraft is porpoising, choose neutral or bow down.

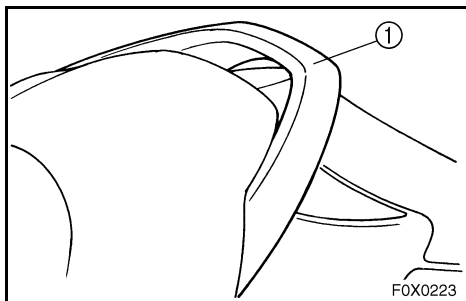

EJU19790

### Handgrip

The handgrip ① provides a handhold for boarding the watercraft.

### **⚠WARNING**

**Do not use the handgrip to lift the watercraft. The watercraft could fall, which could result in severe injury.**





EJU20450

## Engine overheat warning system

This model is equipped with an engine overheat warning system.

If the engine starts to overheat, the warning light and the engine overheat warning indicator begin to blink, and the buzzer sounds intermittently.

When this occurs, reduce the engine speed and beach the watercraft. Check for water discharge. If there is no discharge of water at the cooling water pilot outlet, while the engine is running, check the intake grate and impeller for clogging.

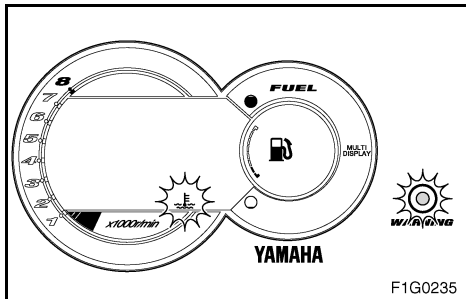

F1G0235

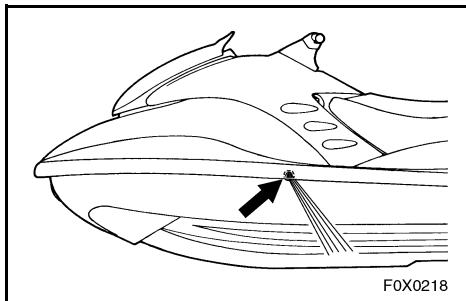

F0X0218

### **⚠ WARNING**

Before attempting to remove weeds or debris from the intake grate or impeller, shut the engine off and remove the clip from the engine shut-off switch. Severe injury or death could result from coming in contact with the rotating parts of the jet pump.

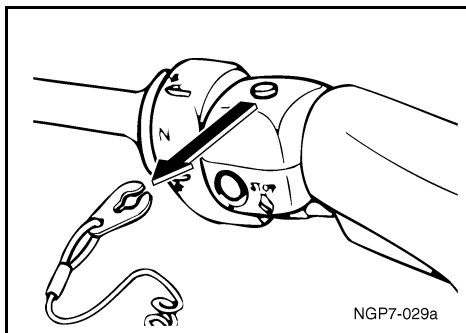

NGP7-029a

### **CAUTION:**

This watercraft is equipped with a catalytic converter.

- Return to shore at low speed if overheat warning indicator and buzzer come on. If you ignore these signals, engine will stop running and cannot be restarted until exhaust system cools down.
- Have your watercraft inspected and serviced by a Yamaha dealer if engine stops due to overheating.

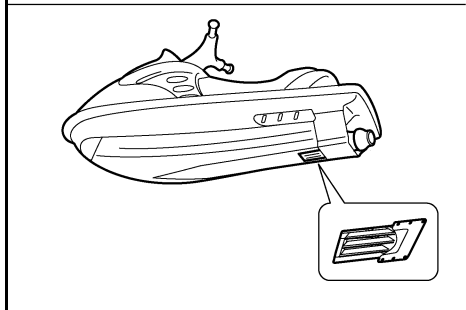



If the overheat warning is ignored, engine and exhaust system heat may increase, particularly if the watercraft is operated at higher speeds. When this occurs, the warning light, the engine overheat warning indicator and the buzzer will change from intermittently to continuously on, and the overheat system will stop ignition to the engine to reduce the risk of severe overheating. The engine cannot be started until it cools down, so it may be necessary to have the watercraft towed back to the beach. (See “Towing the watercraft” on page 5-7 for towing procedures.)

**NOTE:**

Press the select button on the multifunction information center to stop the buzzer.

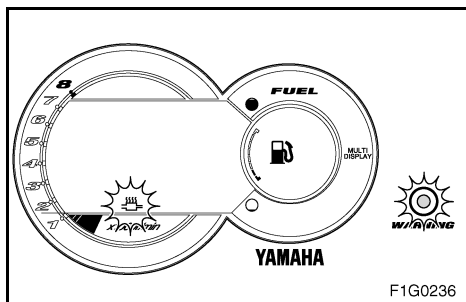

EJU20460

## Exhaust temperature warning system

This model is equipped with an exhaust temperature warning system.

If the exhaust temperature gets too hot, the warning light and exhaust temperature warning indicator begin to blink, and the buzzer sounds intermittently.

When this occurs, reduce engine speed and beach the watercraft to allow the exhaust system to cool down.

**⚠WARNING**

**Hot muffler surfaces can cause serious burns. Do not touch any muffler surface during or after engine operation. The catalytic converter gets hotter after the engine stops.**

**CAUTION:**

This model is equipped with a catalytic converter.

- When the exhaust temperature warning system is activated, reduce engine speed (below 4,000 r/min) and beach the watercraft.
- If you cannot locate and correct the cause of the overheating, consult a Yamaha dealer. Continuing to operate at higher speeds could result in severe engine damage.

**NOTE:**

Press the select button on the multifunction information center to stop the buzzer.

EJU19940

## Yamaha Engine Management System (YEMS)

This model is equipped with an integrated, computerized management system that controls and adjusts ignition timing, fuel injection, engine diagnostics, and the Off-Throttle Steering (OTS) system.



EJU20161

## Multifunction information center

This meter contains following functions for the help and convenience of operation.

- ① Tachometer
- ② Speedometer
- ③ Hour meter/Voltmeter
- ④ Fuel meter
- ⑤ Warning light
- ⑥ Fuel warning indicator
- ⑦ Engine overheat warning indicator
- ⑧ Oil warning indicator
- ⑨ Exhaust temperature warning indicator
- ⑩ Check engine warning indicator
- ⑪ Select button

### CAUTION:

- Do not run the engine over 4,000 r/min to check the meter for operation on land. The engine could overheat or the catalytic converter could result in serious damage.
- Use the specified resistor-type spark plug and cap, otherwise the meter may function erratically.

### NOTE:

All display light up and the buzzer sounds twice after the engine starts. Then, the meter will operate normally after few seconds. The current display will continue to operate for 25 seconds after the engine stops.

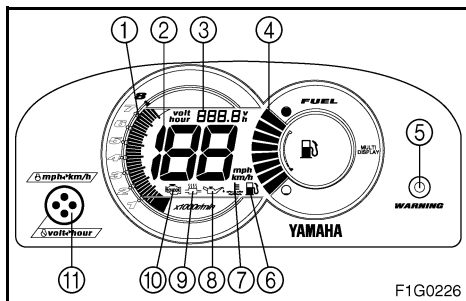
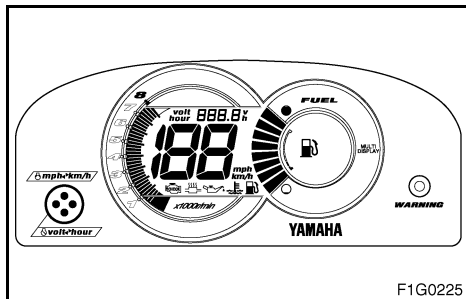

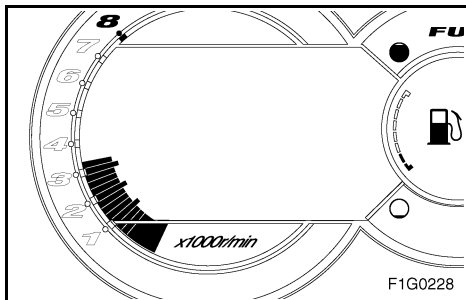

EJU10280

### Tachometer

The engine speed (r/min) is displayed by segments. Each segment indicates a 250 r/min increment.

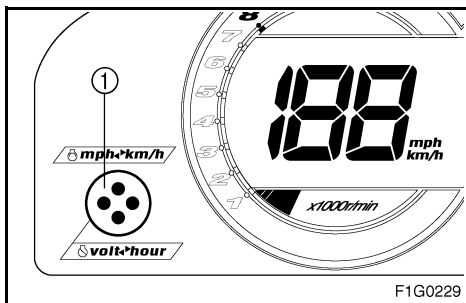

EJU20171

### Speedometer

The meter shows the watercraft speed against water.

**NOTE:** \_\_\_\_\_  
To switch the speedometer display between kilometers and miles, push the select button ① for at least 1 second, within 10 seconds after the meter is displayed.

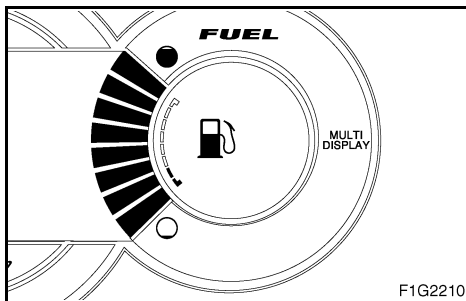

EJU10310

### Fuel meter

The fuel meter is provided for convenient fuel level checking while riding. The fuel meter has eight segments which show the amount of fuel remaining in the fuel tank.

**NOTE:** \_\_\_\_\_  
The indication of the segments differs on your operating condition. Use the meter as a reference.

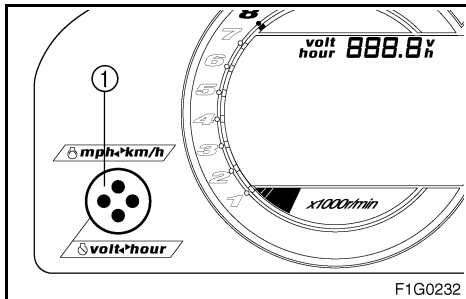

EJU20182

## Hour meter/Voltmeter

### NOTE:

To switch the display between the hour meter and voltmeter, push the select button ① for at least 1 second after the meter is displayed for more than 10 seconds.

### Hour meter

The hour meter is provided to make it easy to follow the maintenance schedule.

The meter shows the hours of engine operation that have elapsed since the watercraft was new.

### Voltmeter

The voltmeter is provided to display the voltage of the battery.

The voltmeter displays 12 volts or more when the battery voltage is within specification.

If the voltage displayed is low, beach the watercraft and, if necessary, have a Yamaha dealer check the charging system.

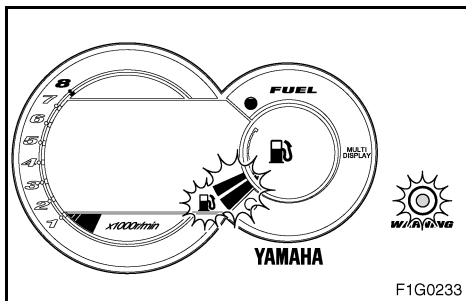

EJU10330

## Fuel warning indicator

If the fuel remaining in the tank drops to about 13 L (3.4 US gal, 2.9 Imp gal), the lowest two fuel level segments, the fuel warning indicator and the warning light begin to blink. The buzzer also starts sounding intermittently.

The warning signals will be cleared when the engine restarts after refilling fuel.

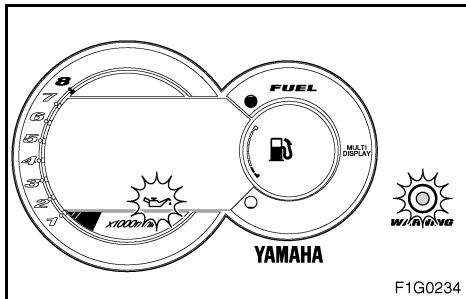

EJU10341

### Oil warning indicator

If the oil remaining in the tank drops to about 1.7 L (0.45 US gal, 0.37 Imp gal) or the oil filter is clogged, the oil warning indicator and the warning light begin to blink. The buzzer also starts sounding intermittently.

If the oil warning indicators begin to blink, refill with engine oil as soon as possible.

The warning signals will be cleared when the engine restarts after refilling engine oil.

**NOTE:** If the warning indicators blink with adequate oil in the tank, have a Yamaha dealer check the oil filter for dirt and clogs.

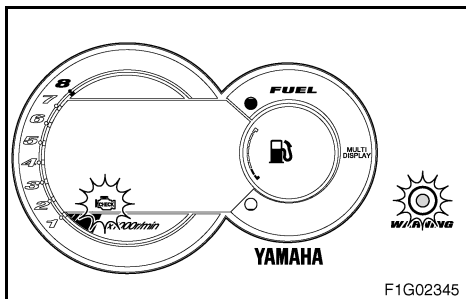

EJU20041

### Check engine warning indicator

If a sensor malfunction or a short circuit is detected, the warning light and indicator begin to blink and the buzzer sounds intermittently.

If this occurs, reduce the engine speed, beach the watercraft, and have a Yamaha dealer check the engine.



EJU20050

## Engine overheat warning indicator

If the engine starts to overheat, the warning light and engine overheat warning indicator begin to blink, and the buzzer sounds intermittently.

If the watercraft continues to be operated at higher speeds after the warning system has been activated, the warning light, engine overheat warning indicator and the buzzer will change from intermittently to continuously on. (See “Engine overheat warning system” on page 2-12 for further details.)

The warning signals will turn off when the engine is started after it has cooled down.

**NOTE:** \_\_\_\_\_

When the warnings overlap each other, their priority is as follows:

1. Final overheat warning
2. Fuel level warning
3. Oil level warning
4. Initial overheat warning
5. Exhaust temperature warning
6. Check engine warning

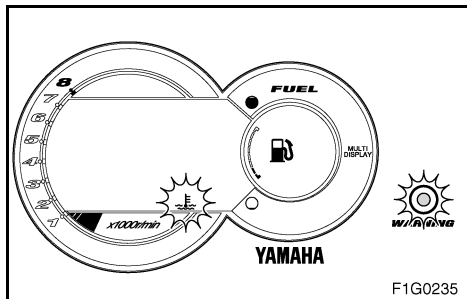

EJU11860

## Exhaust temperature warning indicator

If the exhaust system becomes too hot, the warning light and exhaust temperature warning indicator begin to blink, and the buzzer sounds intermittently. (See “Exhaust temperature warning system” on page 2-13 for further details.)

The warning signals will turn off when the engine is started after it has cooled down.

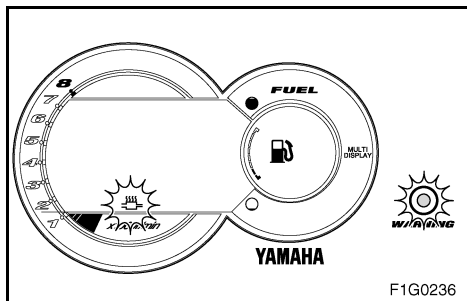



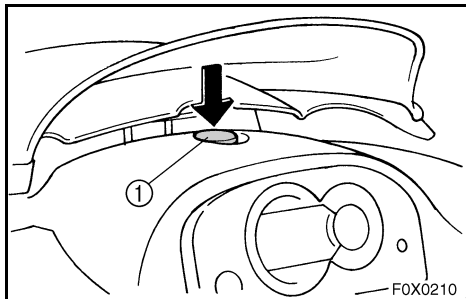

EJU10350

### Storage compartments

A front storage compartment and a glove compartment are provided.

**NOTE:**

- Make sure that the storage compartments are properly secured before operating the watercraft.
- The storage compartments are not designed to be waterproof. If you carry objects that must be kept dry, such as the manuals, put them in a waterproof bag.

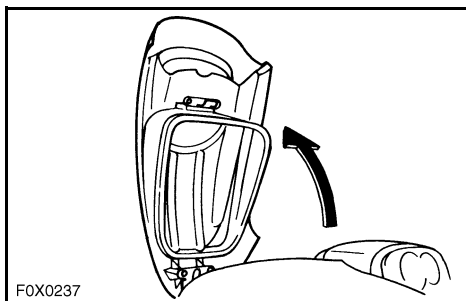

EJU10370

### Front storage compartment

The front storage compartment ② is located at the bow.

To open the front storage compartment, push the hood latch ① down, and then open the hood.

**NOTE:**

The front storage compartment can be removed to access the engine compartment.

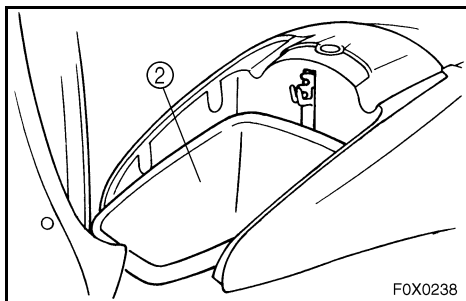

Front storage compartment: Capacity: 16 L (4.2 US gal, 3.5 Imp gal) Load limit: 5 kg (11 lb)
--

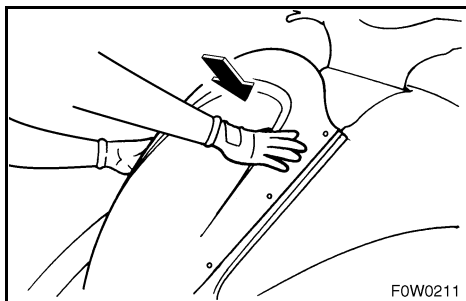

To close the front storage compartment, push down on the rear of the hood until it latches securely.



EJU20470

### Glove compartment

A glove compartment ② is located in front of the seat.

To open the glove compartment, slide the latch ① toward you, and then lift up the lid.

To close the glove compartment, push the lid down until it locks securely.

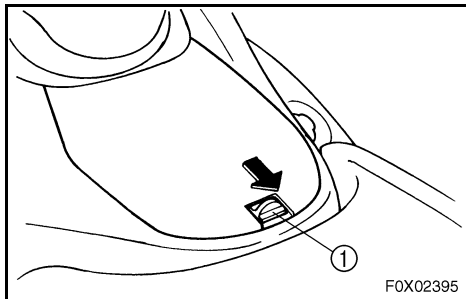

FOX02395

Glove compartment:  
Capacity: 2 L (0.53 US gal, 0.44 Imp gal)  
Load limit: 1 kg (2.2 lb)

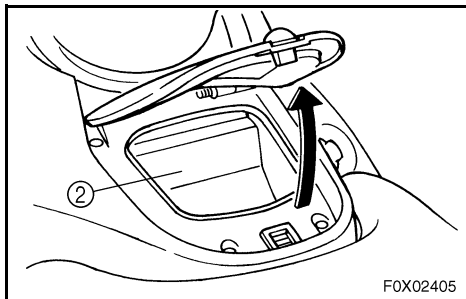

FOX02405

EJU10391

### Yamaha Adjustable Sponson (Y.A.S.)

The sponsons ① have adjustable positioning to allow the operator to enhance either straight-line performance or turning performance according to the preference and operating conditions. (See page 4-22 for adjustment procedures.)

#### Up position ①A:

There will be less water resistance in this position, so straight-ahead acceleration when on plane and top speed will be enhanced.

#### Down position ①B:

This position will give the watercraft more “hook” which will enhance turning performance.

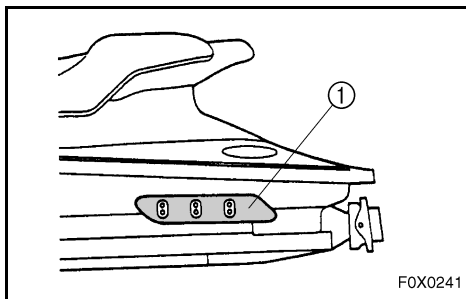

FOX0241

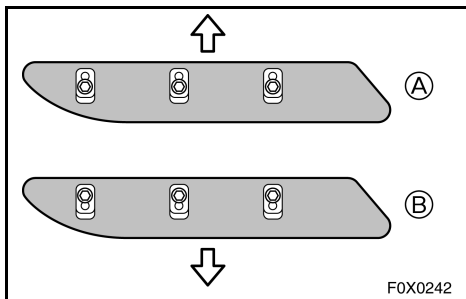

FOX0242

## OPERATION

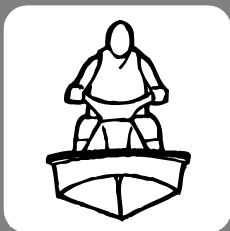

<b>Fuel and oil</b> .....	3-1
Gasoline .....	3-1
2-stroke engine oil .....	3-3
Filling the fuel tank .....	3-4
Filling the oil tank .....	3-5
<b>Pre-operation checks</b> .....	3-6
Pre-operation check list .....	3-6
Pre-operation check points .....	3-7
<b>Operation</b> .....	3-14
Engine break-in .....	3-14
Starting the engine .....	3-16
Stopping the engine .....	3-18
Leaving the watercraft .....	3-18
<b>Operating your watercraft</b> .....	3-19
Getting to know your watercraft .....	3-19
Learning to operate your watercraft ....	3-19
Riding watercraft with a passenger ....	3-20
Starting the watercraft .....	3-21
Boarding and starting in deep water ...	3-23
Capsized watercraft .....	3-25
Turning the watercraft .....	3-27
Stopping the watercraft .....	3-29
Beaching the watercraft .....	3-30
Docking the watercraft .....	3-30
Rough water operation .....	3-30
<b>Post-operation checks</b> .....	3-31
<b>Transporting</b> .....	3-33



## Fuel and oil

This engine uses Yamaha's oil injection system, which provides superior lubrication by ensuring the proper oil ratio for all operating conditions. No fuel premixing is necessary except during the engine break-in period. Simply pour gasoline into the fuel tank and oil into the oil tank.

The engine utilizes an electronic fuel injection system to deliver the optimal air-fuel mixture ratio required by the engine. With optimal combustion conditions, this system is able to increase startability and improve fuel economy.

### Gasoline

#### **⚠WARNING**

**GASOLINE AND ITS VAPORS ARE HIGHLY FLAMMABLE AND EXPLOSIVE!**

- Do not smoke when refueling, and keep away from sparks, flames, or other sources of ignition.
- Stop engine before refueling.
- Refuel in a well-ventilated area with the watercraft in a horizontal position.
- Do not stand or sit on the watercraft while refueling in case of fire.
- Take care not to spill gasoline. If gasoline spills, wipe it up immediately with dry rags. Always properly dispose of gasoline-soaked rags.



- **Avoid overfilling the fuel tank. Stop filling when the fuel level just reaches the bottom of the filler tube. Do not fill up the filler tube because fuel expands as it warms up and could overflow. If temporarily leaving the watercraft with a full fuel tank, do not leave it in direct sunlight. Leave it in a well-ventilated area with the watercraft in a horizontal position.**
- **Tighten the filler cap securely after refueling.**
- **If you should swallow some gasoline, inhale a lot of gasoline vapor, or get gasoline in your eyes, get immediate medical attention.**
- **If any gasoline spills onto your skin, immediately wash with soap and water. Change clothing if gasoline spills on it.**

**CAUTION:**

- **Do not use leaded gasoline. Leaded gasoline can seriously damage the catalytic converter.**
- **Use only fresh gasoline that has been stored in clean containers.**

Recommended gasoline:

Regular unleaded gasoline with  
a minimum octane rating of

86 (Pump octane number) =  $(R+M)/2$

90 (Research octane number)



EJU18320

## Gasohol

There are two types of gasohol: gasohol containing ethanol and that containing methanol.

Gasohol containing ethanol can be used if ethanol content does not exceed 10% and the fuel meets minimum octane ratings.

Gasohol containing methanol is not recommended by Yamaha because it can cause fuel system damage or engine performance problems.

EJU11870

## 2-stroke engine oil

### CAUTION:

**Use only YAMALUBE 2-W oil. Using another oil can seriously damage the catalytic converter and other engine components.**

Recommended engine oil:  
YAMALUBE 2-W oil only

### NOTE:

YAMALUBE 2-W is developed for this watercraft and available from a Yamaha dealer.



EJU20190

## Filling the fuel tank

### CAUTION:

**Be careful when refueling. Avoid getting water or other contaminants in the fuel tank. Contaminated fuel can cause poor running or engine damage.**

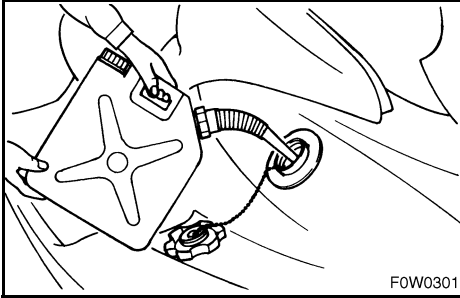

1. Open the hood and remove the front storage compartment, to check the fuel level. (See page 2-20 for front storage compartment.)
2. Open the fuel tank filler cap, and slowly add fuel to the fuel tank.
3. Stop filling when the fuel just reaches the bottom of the filler tube on the fuel tank. Do not fill into the filler tube, because fuel could spill out.

Fuel tank capacity:

Total: 60 L (15.9 US gal, 13.2 Imp gal)



EJU10460

## Filling the oil tank

### **⚠ WARNING**

- Do not add gasoline to the oil tank. Fire or explosion could result.
- Oil in the bilge is a serious fire hazard. Wipe up any spilled oil immediately.

### **CAUTION:**

Do not allow the oil tank to become completely empty. If the oil tank becomes empty the oil injection pump must be bled to ensure proper oil flow, otherwise engine damage may occur. If bleeding of the oil pump is necessary, have a Yamaha dealer bleed it.

1. Remove the seat to watch the oil level. (See page 2-5 for seat.)
2. Open the oil tank filler cap, and very slowly add engine oil to the oil tank.
3. Stop filling when the oil just reaches the top of oil tank visible.

Oil tank capacity:  
5.5 L (1.5 US gal, 1.2 Imp gal)

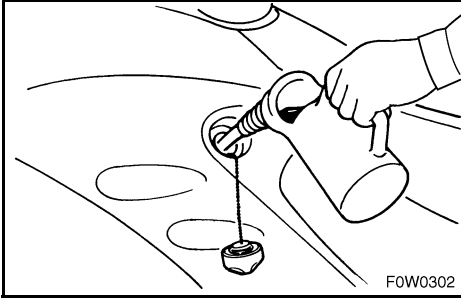





EJU13460

## Pre-operation checks

EJU13470

### Pre-operation check list

Before operating this watercraft, perform the checks in the following check list. See the accompanying text in this chapter for details on how to perform the checks.

#### **⚠ WARNING**

**If any item in the pre-operation check list is not working properly, have it inspected and repaired before operating the watercraft, otherwise an accident could occur.**

ITEM	ROUTINE	PAGE
Engine compartment	Remove the seat and front storage compartment to ventilate engine compartment. Check for fuel vapors or loose electrical connections	3-7
Bilge	Check for water and fuel residue and remove if necessary	3-8
Throttle	Check that the throttle lever springs back	3-11
Steering system	Check for proper steering system operation	3-11
Fuel and oil	Check fuel and oil level and add if necessary Check hoses and tanks for leakage	3-7
Water separator	Check for water and drain if necessary	3-8
Battery	Check electrolyte level and battery condition	3-9
Hood	Check that the hood is properly secured	2-6
Seat	Check that the seat is properly secured	2-5
Hull/Deck	Check the hull and deck for cracks or other damage	—
Jet unit	Check for debris and remove if necessary	3-12
Fire extinguisher	Check the condition and replace if necessary	3-10
Engine shut-off cord	Check condition and replace if frayed or broken	3-12
Switches	Check the start switch, engine stop switch and engine shut-off switch for proper operation when the watercraft is in the water	3-13
Cooling water pilot outlet	Check that water is discharged while the engine is running and the watercraft is in the water	3-13
Multifunction information center	Check for warning indications and proper operation	3-13

#### **NOTE:**

Pre-operation checks should be made thoroughly each time the watercraft is used. This procedure can be completed in a short time. It is worth the time spent to assure safety and reliability.

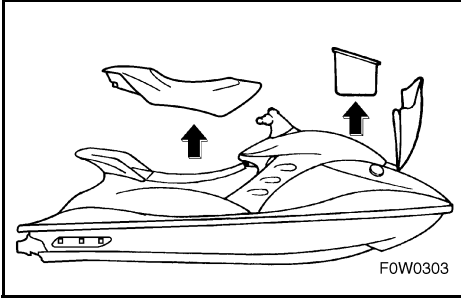

EJU10480

## Pre-operation check points

EJU10500

### Engine compartment

Ventilate the engine compartment before each use.

To ventilate the engine compartment, remove seat and front storage compartment. (See page 2-5 for seat, and 2-20 for front storage compartment.) Allow the engine compartment to remain open for a few minutes to allow any fuel vapors to escape. Also, check for loose electrical connections.

#### **⚠WARNING**

**Failure to ventilate the engine compartment could result in fire or explosion. Do not start the engine if there is a fuel leak or a loose electrical connection.**

EJU20071

### Fuel and oil systems

Check the fuel system for leakage, cracks or malfunctions before each use. (See page 4-10 for check points and correct procedures.)

1. Remove the fuel tank filler cap to release any pressure that might have built up in the fuel tank.
2. Remove seat and front storage compartment. (See page 2-5 for seat, and 2-20 for front storage compartment.)
3. Check the fuel and oil levels in the tanks and replenish if necessary. (See pages 3-4 and 3-5 for filling instructions.)

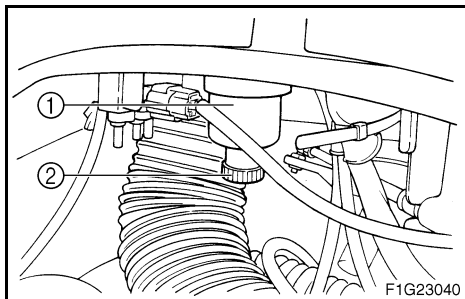

EJU19610

## Water separator

Check the water separator ① for water. Normally the water separator is empty. The water separator retains any water entering through the fuel tank breather hose if the watercraft is capsized.

If water remains in the water separator, drain it by removing the drain screw ②. Place a drain pan under the water separator to catch the draining water or use a dry cloth to soak up any water that could spill into the watercraft. If any water spills into the watercraft, be sure to wipe it up with a dry cloth. Be sure to install the drain screw after draining the water separator.

EJU20200

## Bilge

Check for moisture and fuel residue in the bilge.

This watercraft is equipped with a conventional jet vacuum bilge draining system and an electric bilge draining system. The electric bilge draining system is operated when the engine is running. When excess water reaches the water inlet of the electric bilge pump, the water is discharged via the exhaust passage from the jet thrust nozzle.

A small quantity of water will remain in the bilge and should be removed manually. To remove any residual water, perform the following procedure.

### To remove water from the bilge:

1. Remove the stern drain plugs.
2. Raise the bow of the watercraft until the water drains.
3. After the water has drained, wipe the bilge with dry rags to make sure that the bilge is thoroughly dry.
4. Install the drain plugs.

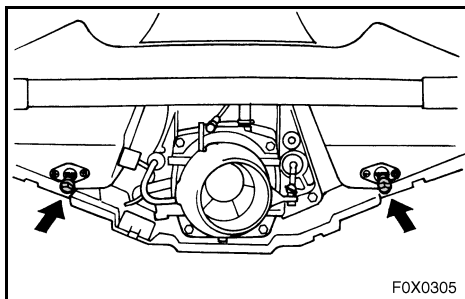

**CAUTION:**

- Make sure that the stern drain plugs are tightened securely before launching the watercraft.
- Clean any foreign materials, such as dirt or sand, from the drain plug threads before installing the drain plugs.

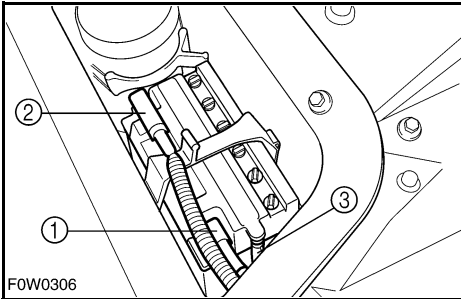

FOW0306

EJU19690

**Battery**

Check the battery condition and the electrolyte level.

Check that the battery leads are tightened securely and there is no corrosion on the battery terminals.

**⚠ WARNING**

- The battery must always be fully charged and in good condition. Loss of battery power may leave you stranded. Never operate the watercraft if the battery does not have sufficient power to start the engine or if it shows any other signs of decreased power.
- Be sure to connect the breather hose to the battery. Fire or explosion could result if the breather hose is damaged, obstructed, or not connected properly.

Make sure that the battery is securely held in place.

- ① Positive (+): Red lead
- ② Negative (-): Black lead
- ③ Breather hose

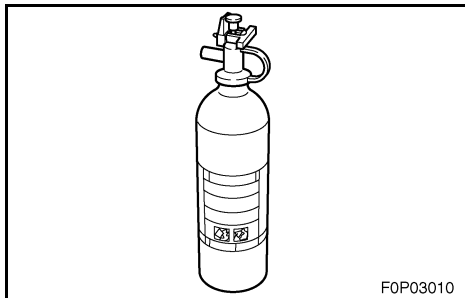

EJU10550

### Fire extinguisher

Check that there is a full fire extinguisher on board. The fire extinguisher container ① is located in the battery compartment.

To open the fire extinguisher container cap ② remove the seat and turn it counter-clockwise.

After inserting the fire extinguisher make sure that the container cap is tightened securely.

#### NOTE:

- See the instructions supplied by the fire extinguisher manufacturer for checking the fire extinguisher. Always keep the extinguisher in the fire extinguisher container.
- Always carry a fire extinguisher on board. A fire extinguisher is not standard equipment with this watercraft. If you do not have one, contact a Yamaha dealer or a fire extinguisher dealer to obtain one meeting the proper specifications.

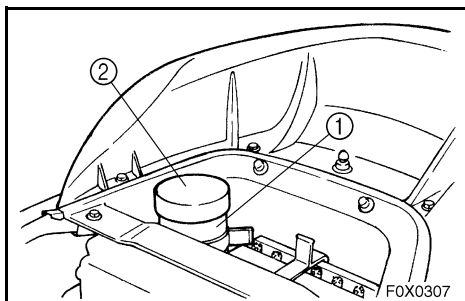

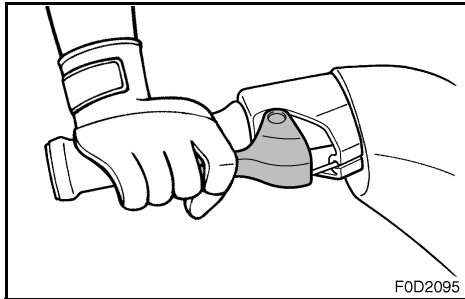

EJU18340

### Throttle

Squeeze and release the throttle lever several times to make sure that there is no hesitation in its travel. It should be smooth over the complete range, and spring back to the idle position when released.

**⚠WARNING**

**Before starting the engine, always check the operation of the throttle lever.**

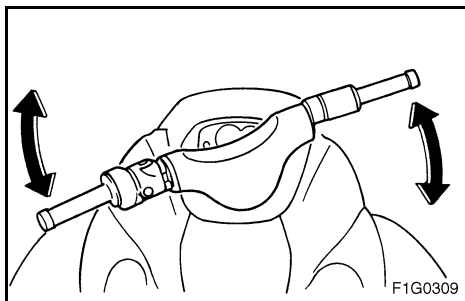

EJU10570

### Steering system

Check for looseness in the handlebars.

Turn them as far as possible to the right and left to make sure that operation is smooth and unrestricted throughout the whole range. Make sure that the jet thrust nozzle also changes directions as the handlebars are turned, and that there is no free play between the handlebars and the jet thrust nozzle.



EJU10580

## Jet unit

Carefully check the jet intake for weeds, debris, or anything else that might restrict the intake of water. If the intake is clogged, cavitation could occur, reducing jet thrust, and possibly damaging the jet pump.

In some cases, the engine may overheat because of lack of cooling water, and damage to the engine could result. Engine cooling water is fed to the engine by the jet pump. (See page 5-4 for jet intake cleaning procedures.)

### **⚠ WARNING**

- Keep away from intake grate while engine is on. Items such as long hair, loose clothing, or PFD straps can become entangled in moving parts resulting in severe injury or drowning.
- Stop the engine and remove the clip from the engine shut-off switch before removing any debris or weeds, which may have collected around the jet intake.

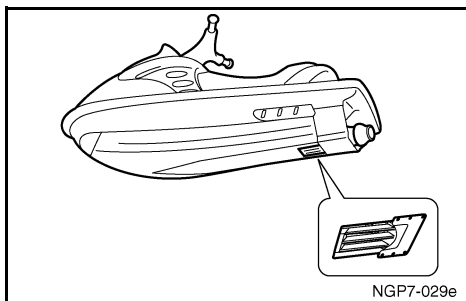
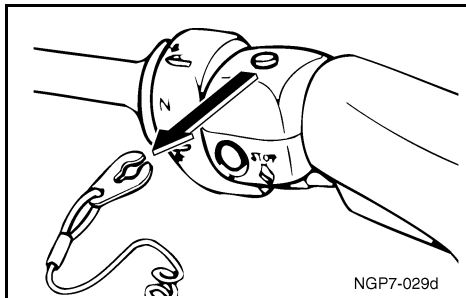

EJU10590

## Engine shut-off cord (lanyard)

Check that the engine shut-off cord is not frayed or broken. If the cord is damaged, replace it; never try to repair it or tie it together.

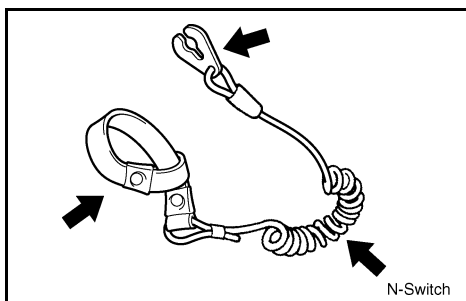

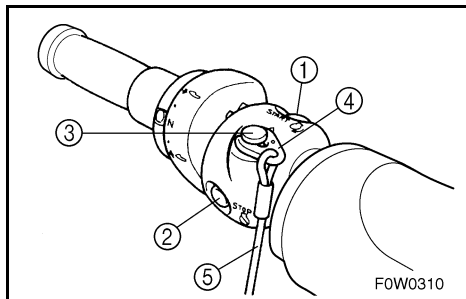

EJU18350

## Switches

Check the start switch ①, the engine stop switch ②, and the engine shut-off switch ③ for proper operation.

To check these switches, place the watercraft in the water to provide adequate cooling. Start the engine, and then pull the engine shut-off cord ⑤ to remove the clip ④ from the engine shut-off switch. Verify that the engine stops immediately. (See pages 2-7 to 2-8 for information on proper operation of the start switch, the engine stop switch and the engine shut-off switch.)

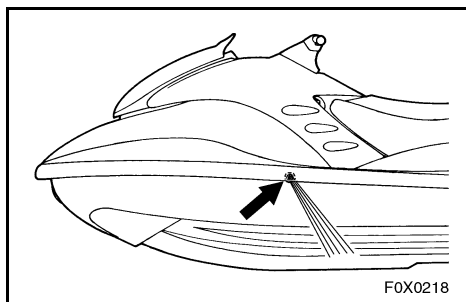

EJU10610

## Cooling water pilot outlet

Check that water comes out from the outlets while the engine is running and the watercraft is in the water.

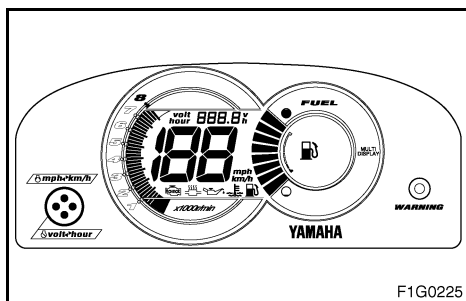

EJU10620

## Multifunction information center

Check the operation of the multifunction information center. (See pages 2-15 to 2-19 for multifunction information center.)





EJU18360

## Operation

### **⚠ WARNING**

Before operating your watercraft, become familiar with all controls. Consult your Yamaha dealer about any control or function you do not fully understand. Failure to understand how controls work could cause an accident or prevent you from avoiding an accident.

### **CAUTION:**

Make sure that the stern drain plugs are securely tightened before launching the watercraft.

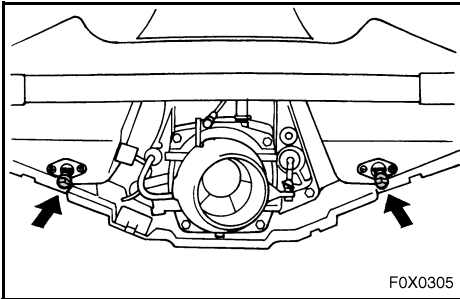

EJU18810

## Engine break-in

The engine break-in period is essential to allow the various components of the engine to wear and polish themselves to the correct operating clearances. This ensures proper performance and promotes longer component life.

### **CAUTION:**

- For the first tankful of operation, pre-mix a 50:1 mixture of fuel and oil (in addition to the oil in the oil tank).
- After break-in, use straight gasoline for normal operation.



1. Launch the watercraft and start the engine. (See page 3-16 for engine starting procedures.)
2. Run the engine at the lowest possible speed for 5 minutes.
3. Gradually open the throttle and run the engine at 5,000 r/min or less.
4. Continue operation at 5,000 r/min or less until the first tankful of fuel has been used.
5. Fill the tank with straight gasoline, and then proceed with normal operation.

**CAUTION:**

**Failure to follow the engine break-in procedure properly can result in severe damage to the engine.**



EJU18080

## Starting the engine

### **⚠WARNING**

Never start the engine or let it run for any length of time in an enclosed area. Exhaust fumes contain carbon monoxide, a colorless, odorless gas that may cause loss of consciousness and death within a short time. Always operate the watercraft in an open area.

1. Launch the watercraft in water free from weeds and debris and at least 60 cm (2 ft) deep.

### **⚠WARNING**

Never operate in water that is less than 60 cm (2 ft) deep, otherwise you increase your chance of hitting a submerged object, which could result in injury.

### **CAUTION:**

Never operate in water that is less than 60 cm (2 ft) deep, otherwise pebbles or sand could be sucked into the jet intake, causing impeller damage or engine overheating.

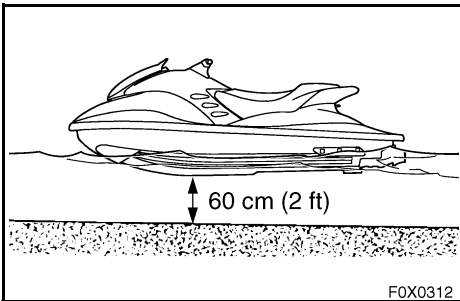

F0X0312

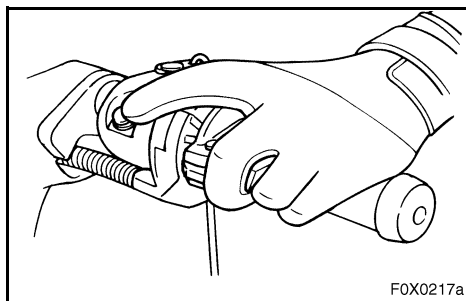
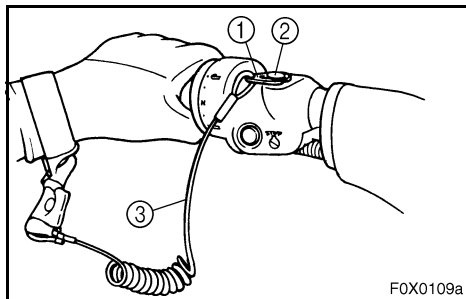

2. Attach the clip ① to the engine shut-off switch ②. Also, attach the engine shut-off cord ③ to your left wrist.

**WARNING**

Check that the engine shut-off cord is not frayed or broken, and keep it free from the handlebars so the engine stops if the operator falls off. The engine shut-off cord may not pull free if wrapped around the handlebars when the operator falls off, allowing the watercraft to continue to run and cause an accident.

**NOTE:**

It is not possible to start the engine with the clip removed from the engine shut-off switch.

3. Push the start switch (green button).

**NOTE:**

The engine will not start if the throttle lever is squeezed.

4. Release the start switch as soon as the engine starts to run.

**CAUTION:**

- Never push the start switch while the engine is running.
- Do not operate the start switch for more than 5 seconds, otherwise the battery will be discharged and the engine will not start. Also, the starter motor may be damaged. If the engine does not start in 5 seconds, release the start switch, wait 15 seconds, and then try again.

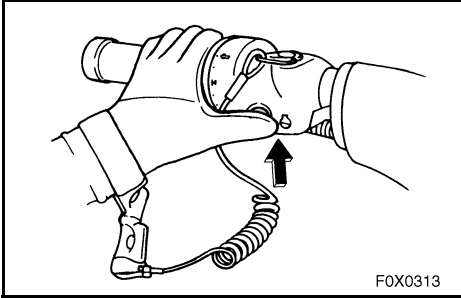

EJU10660

## Stopping the engine

To stop the engine, release the throttle lever, and then push the engine stop switch (red button).

### **⚠WARNING**

**You need throttle to steer. Shutting off the engine can cause you to hit an obstacle you are attempting to avoid. A collision could result in severe injury or death.**

EJU10670

## Leaving the watercraft

If leaving the watercraft, remove the engine shut-off cord to reduce the chance of accidental starting or unauthorized use by children or others.



EJU10680

## Operating your watercraft

EJU10690

### Getting to know your watercraft

Operating your watercraft requires skills acquired through practice over a period of time. Take the time to learn the basic techniques well before attempting more difficult maneuvers.

Operating your new watercraft can be a very enjoyable activity, providing you with hours of pleasure. However, it is essential to familiarize yourself with the operation of the watercraft to achieve the skill level necessary to enjoy riding safely. Before operating this watercraft, read this Owner's/Operator's Manual, the Riding Practice Guide, and all warning and caution labels on the watercraft. Pay particular attention to the safety information on pages 1-9 to 1-15. These materials should give you an understanding of the watercraft and its operation.

Remember: This watercraft is designed to carry the operator and one passenger. Never exceed the maximum load limit or allow more than 2 persons to ride the watercraft at one time.

Maximum load: 160 kg (353 lb)  
Load is the total weight of cargo, operator and passenger.

EJU10700

### Learning to operate your watercraft

Before operating the watercraft, always perform the pre-operation checks listed on page 3-6. The short time spent checking the watercraft will reward you with added safety and reliability.

Check all local laws before operating your watercraft.

Operate defensively at safe speeds and keep a safe distance away from people, objects, and other watercraft. Select a wide area to learn in, where you have good visibility and light boat traffic.

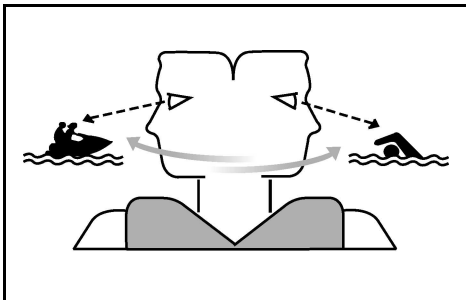

Use the buddy system—operate with someone nearby. Scan constantly for people, objects, and other watercraft. Be alert for conditions that limit your visibility or block your vision of others.

Attach the engine shut-off cord (lanyard) to your wrist and keep it free from the handlebars so that the engine stops if the operator falls off.

Wear a personal flotation device (PFD). All riders must wear an authority-approved PFD that is suitable for personal watercraft use.



Wear protective clothing. Severe internal injuries can occur if water is forced into body cavities as result of falling into the water or being near the jet thrust nozzle. Normal swimwear does not adequately protect against forceful water entry into rectum and vagina. All riders must wear a wetsuit bottom or clothing that provides equivalent protection.

Such clothing includes thick, tightly woven, sturdy and snug-fitting apparel such as denim, but does not include spandex or similar fabrics like those used in bicycle shorts. A full wetsuit can also protect against hypothermia (subnormal body temperature) and abrasions.

Footwear and gloves are recommended.

Eye protection is recommended to keep wind, water, and glare from the sun out of your eyes while you operate your watercraft. Restraining straps for eyewear are made which are designed to float should your eyewear fall in the water.

You should grip the handlebars firmly and keep both feet on the floor of the footwell. Do not attempt to ride with passengers until your operating skills are fully developed.

EJU10710

## Riding watercraft with a passenger

When a passenger is on board with the operator, the watercraft handles differently, and is not as easy to maneuver, so operating it requires a higher degree of skill. Before attempting to operate the watercraft with a passenger on board, the operator must practice operating the watercraft alone enough to be able to acquire the necessary skills.

The passenger must always wear an authority-approved PFD and a wetsuit bottom or equivalent.

### **⚠WARNING**

**Do not apply throttle when anyone is at rear of watercraft. Turn engine off or keep engine at idle. Water and/or debris exiting the jet thrust nozzle can cause severe injury. The passenger should not attempt to board the watercraft if the operator is applying throttle.**

Do not give a ride to a child whose feet cannot reach the floor of the footwell. The passenger should hold on firmly to the operator and keep both feet in the footwell.

### **⚠WARNING**

**When a passenger is on board, make sure that he or she is holding on firmly and has his or her feet in the footwell before you start to accelerate.**



EJU18370

## Starting the watercraft

### **⚠WARNING**

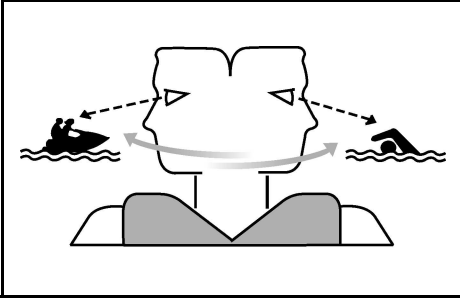

- Scan constantly for people, objects, and other watercraft. Be alert for conditions that limit your visibility or block your vision of others.
- Operate defensively at safe speeds and keep a safe distance away from people, objects, and other watercraft.
- Do not follow directly behind watercraft or other boats. Do not go near others to spray or splash them with water. Avoid sharp turns or other maneuvers that make it hard for others to avoid you or understand where you are going. Avoid areas with submerged objects or shallow water.
- Take early action to avoid collisions. Remember watercraft and other boats do not have brakes. Do not release the throttle when trying to steer away from objects—you need throttle to steer.
- Practice reboarding in shallow water before riding in deep water.



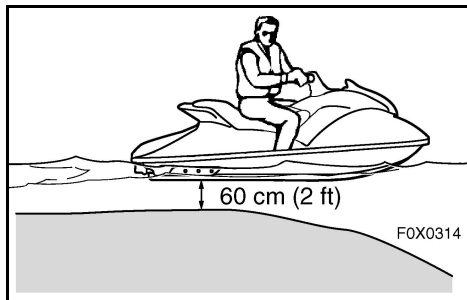

EJU10730

### Starting and boarding in shallow water

1. Do not start the engine in less than 60 cm (2 ft) of water. Put the watercraft in water that is deep enough, and then board the watercraft from the side or the rear.
2. Attach the engine shut-off cord to your left wrist, and then install the clip to the engine shut-off switch.
3. Grip the handlebars with both hands, place both feet on the floor of the foot-well, start the engine, and start off.

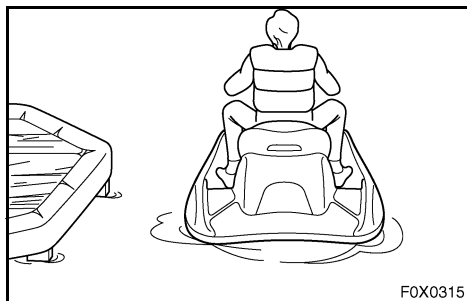

EJU10740

### Starting from a dock

1. Board the watercraft from the side.
2. Attach the engine shut-off cord to your left wrist, and then install the clip to the engine shut-off switch.
3. Push the watercraft away from the dock, grip the handlebars with both hands, place both feet on the floor of the foot-well, start the engine, and start off.



EJU10750

## Boarding and starting in deep water

### **⚠WARNING**

- Operator and passenger should practice getting on board in shallow water before riding in deep water. Boarding in deep water requires more skill.
- The fatigue and exposure that could result after unsuccessful attempts to get back on the watercraft may increase the risk of injuries and drowning.

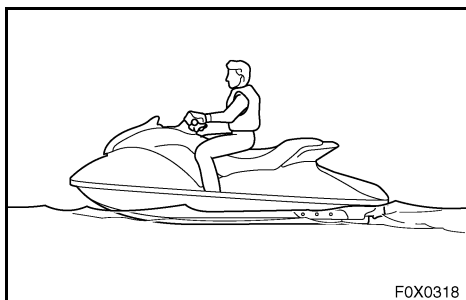
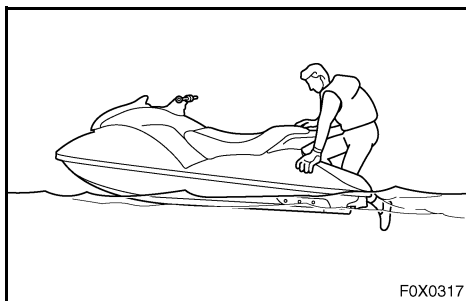
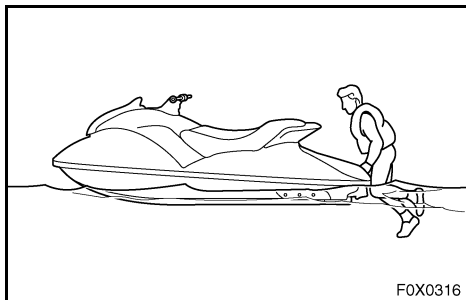

EJU18380

## Boarding alone

1. Swim to the rear of the watercraft and place both hands on the boarding platform, pull yourself up, and then grasp the handgrip with one hand.
2. Pull yourself up to a kneeling position on the platform, and then move to the seat and sit astride.
3. Attach the engine shut-off cord to your left wrist, and then install the clip to the engine shut-off switch.
4. Grip the handlebars firmly with both hands, place both feet on the floor of the footwell, start the engine, and then look in all directions before starting off.

### **⚠WARNING**

**Before starting off, make sure that there are no boats, obstructions, or swimmers around you.**



EJU10770

## Boarding with a passenger

### **⚠WARNING**

Severe internal injuries can occur if water is forced into body cavities as a result of being near the jet thrust nozzle. Do not apply throttle until the passenger is seated with his or her feet on the floor of the footwell and is holding on to the operator.

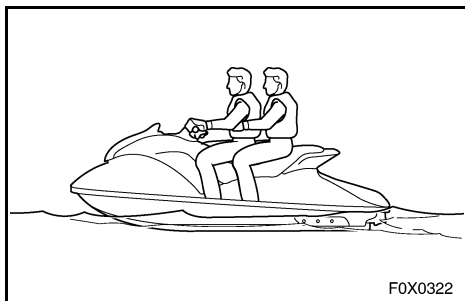
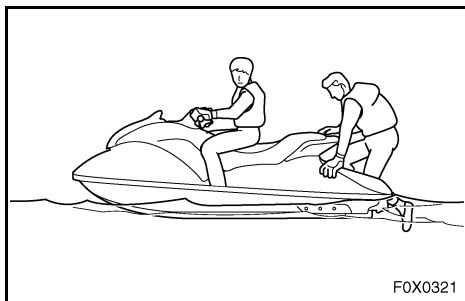
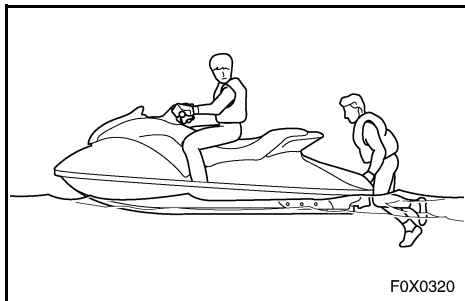
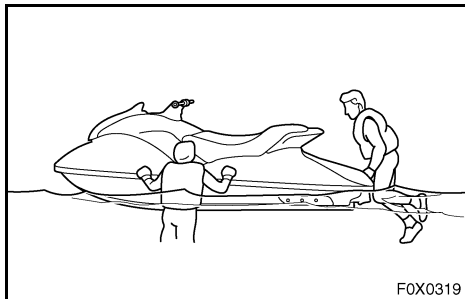

1. Climb on board as noted in the previous section, and sit astride the seat. Attach the engine shut-off cord to your wrist, and then install the clip to the engine shut-off switch.
2. Have the passenger move to the rear of the watercraft.
3. Have the passenger get on board and sit on the seat.

### **NOTE:**

When a passenger is getting on board, both the passenger and the operator should try to balance the watercraft.

4. The operator should check to see that the passenger has his or her feet on the floor of the footwell and that he or she is securely holding on to the operator.
5. Start the engine, look in all directions, and then accelerate to planing speed.

### **⚠WARNING**

Before starting off, make sure that there are no boats, obstructions, or swimmers around you.

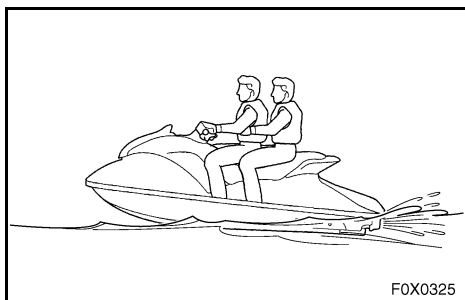
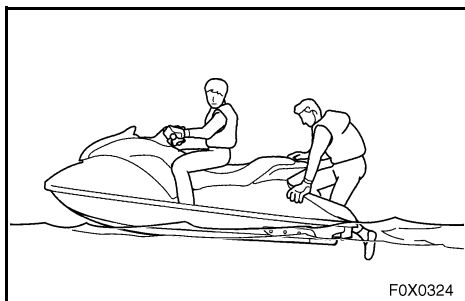
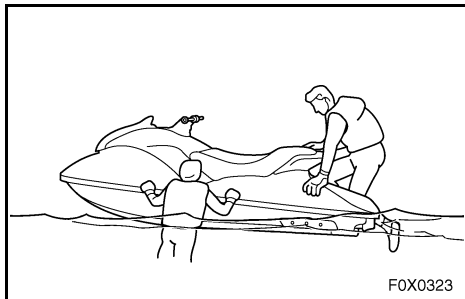
**NOTE:**

The heavier the total weight of the operator and passengers, the more difficult it will be to balance the watercraft. Do not operate the watercraft when the total weight exceeds 160 kg (353 lb) including any cargo. If it is difficult to balance the watercraft at a standstill, proceed as follows:

1. The passenger must steady the watercraft while the operator is boarding. The operator pulls himself up onto the platform into a seating position, then balances the watercraft.
2. Attach the lanyard to your left wrist, then install the clip on the lanyard to the engine shut-off switch. Start the engine and keep it at idle.
3. The passenger pulls himself up on the platform, kneels down, then crawls onto the seat as the watercraft accelerates.
4. The watercraft can now be accelerated to planing speed, then the operator can reduce the throttle to the desired running speed.

EJU20081

**Capsized watercraft**

If the watercraft capsizes, follow the procedures below carefully to prevent damage or injury.

**⚠WARNING****IMPROPER UPRIGHTING CAN CAUSE INJURY:**

- Make sure that the engine shut-off cord is removed from the engine shut-off switch.
- Do not put your hand in the intake grate.
- Watch so you are not hit by the watercraft as it comes over.

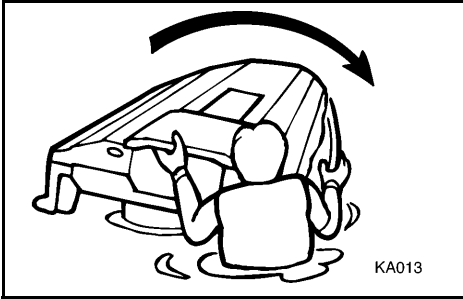

1. Remove the clip from the engine shut-off switch.
2. Swim to the rear of the watercraft. Pull the watercraft over with your left hand on the ride plate while pushing down on the gunwale with your right hand and foot.

**NOTE:**

If the port (left) side of the capsized watercraft is tilting upward, first tilt the watercraft so the port (left) side is down by using your weight to press down on the gunwale.

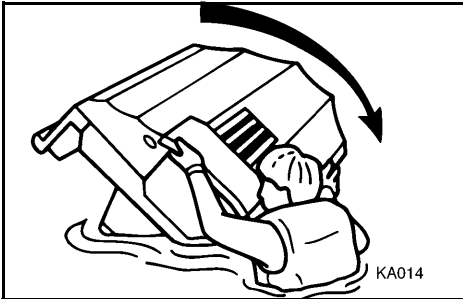

**CAUTION:**

**Do not turn the watercraft over counterclockwise, otherwise water may leak into the engine and cause damage.**

3. Start the engine, and then head for shore to inspect the engine for water damage.

**CAUTION:**

**If the watercraft has been capsized for 5 minutes or more, air may have entered the oil injection system. Leave the engine off, or operate only at trolling speed, for 10 minutes after the watercraft has been turned right-side up. This will allow any air to bleed off.**



EJU19960

## Turning the watercraft

Steering control depends on the combination of handlebar position and the amount of throttle.

Water sucked in through the intake grate is pressurized by the impeller in the jet pump. As the pressurized water is expelled from the pump through the jet thrust nozzle, it creates thrust to move and steer the watercraft. The higher the engine speed, the more thrust produced.

The amount of jet thrust, in addition to the position of the handlebars, determines how sharply you turn.

- A. More throttle produces higher thrust, so the watercraft will turn more sharply.
- B. Less throttle produces lower thrust, so the watercraft will turn more gradually.
- C. Releasing the throttle lever completely produces only minimum thrust. If you are traveling at speeds above trolling, you will have rapidly decreasing ability to steer without throttle. You may still have some turning ability immediately after releasing the throttle lever, but once the engine slows down, the watercraft will no longer respond to handlebar input until you apply throttle again or you reach trolling speed.

At trolling speed, the watercraft can be turned gradually by handlebar position alone using just the amount of thrust available at idle.

- D. If the engine is stopped while riding, there is no thrust. The watercraft will go straight even though the handlebars are turned.

**You need throttle to steer.**

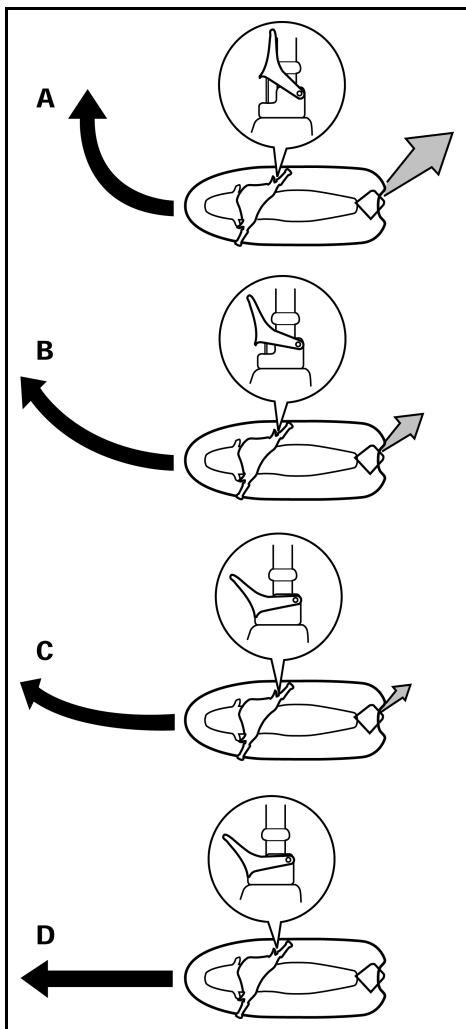
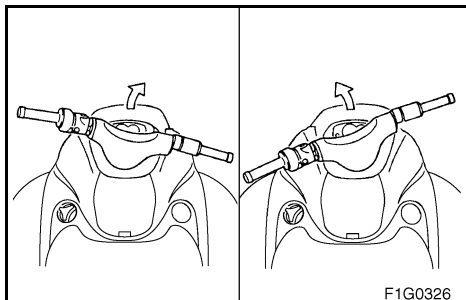

**⚠WARNING**

- **Do not release the throttle lever when trying to steer away from objects—you need throttle to steer. A collision could result in severe injury or death.**
- **When operating at higher speeds, make gradual turns or slow down before turning. Sharp high-speed turns may cause the watercraft to slide sideways or spin, throwing the operator and passengers overboard which could cause an injury.**

This model has the Yamaha Engine Management System (YEMS) that includes an Off-Throttle Steering (OTS) system. It will activate at planing speeds should you attempt to steer the watercraft after releasing the throttle lever (see condition C above). The OTS system assists in turning by continuing to supply some thrust while the watercraft is decelerating, but you can turn more sharply if you apply throttle while turning the handlebars. The OTS system does not function below planing speeds or when the engine is off. Once the engine slows down, the watercraft will no longer turn in response to handlebar input until you apply throttle again or you reach trolling speed.



EJU10800

## Stopping the watercraft

The watercraft is not equipped with a separate braking system. It is stopped by water resistance when the throttle lever is released. From full speed, the watercraft comes to a complete stop in approximately 125 m (410 ft) after the throttle is released and the engine is stopped, although this distance will vary depending on many factors, including gross weight, water surface conditions, and wind direction. The watercraft slows down as soon as the throttle lever is released, but will coast for a distance before fully stopping. If you are not sure you can stop in time before hitting an obstacle, apply throttle and turn in another direction.

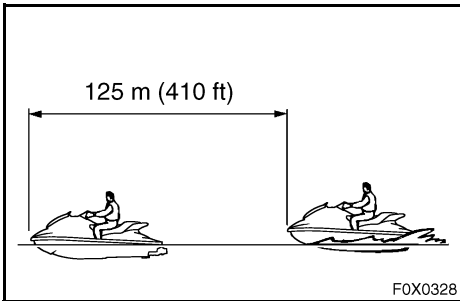

### **⚠ WARNING**

- **Allow adequate stopping distance.**
- **Take early action to avoid collisions. Remember, watercraft and other boats do not have brakes.**
- **Operate defensively at safe speeds and keep a safe distance away from people, objects, and other watercraft to give you time to stop.**
- **Do not shut the engine off when slowing down in case you need engine power to steer away from a boat or other obstacle that comes into your path.**





EJU10810

## Beaching the watercraft

1. Make sure no obstructions, boats or swimmers are near the beach. Release the throttle lever about 125 m (410 ft) before you reach the intended beaching area.
2. Approach the beach slowly and stop the engine before reaching land.  
Remember: you need throttle to steer.
3. Get off the watercraft and pull it up on the beach.

### CAUTION:

**Small pebbles, sand, seaweed, and other debris can be pulled into the jet intake and impair or damage the impeller. Always stop the engine and get off before beaching the watercraft.**

EJU10820

## Docking the watercraft

1. Make sure that no obstructions, boats or swimmers are close to the watercraft. Reduce speed about 125 m (410 ft) away from the dock.
2. Slowly approach the dock and stop the engine just before coming alongside it.

EJU10830

## Rough water operation

The force of landing after jumping can cause a strong impact on both the watercraft and the operator and passenger. It is possible for the operator to hit his or her chest or jaw on the watercraft body or handlebars and be injured. Do not operate the watercraft with your chin right above the handlebars or with your feet outside the watercraft. Operating in rough water or jumping waves can also crack the watercraft body or damage internal parts. Avoid operating in rough water or bad weather conditions.



EJU20210

## Post-operation checks

### **⚠WARNING**

**Stay away from stern when engine is running on land. Hot water and steam spurting from exhaust outlet into the air can cause serious burns.**

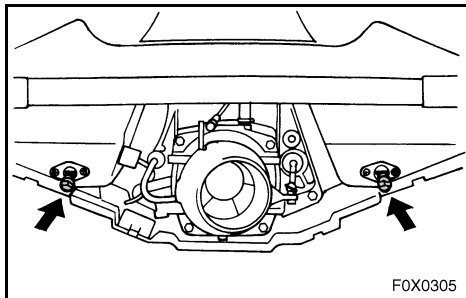

Always perform the following post-operation checks after operating the watercraft.

1. Remove the watercraft from the water.
2. Wash down the hull, handlebars, and jet unit with fresh water.
3. Remove the seat and check the engine compartment for water. To drain excess water, remove the stern drain plugs, and then raise the bow of the watercraft enough to allow water in the bilge to drain out.

### **NOTE:**

This watercraft is equipped with a jet vacuum bilge draining system and an electric bilge draining system that remove water from the engine compartment while you are underway. However, some residual water will remain. (See “Bilge” on page 3-8 for more information.)

4. Put the watercraft in a horizontal position.
5. Flush the cooling system to prevent it from clogging with salt, sand, or dirt. (See page 4-1 for flushing procedures.)
6. Drain residual water from the exhaust system by running the engine at 4,000 r/min for 10 to 15 seconds.

### **CAUTION:**

**Do not run engine over 4,000 r/min on land. Otherwise catalytic converter could sustain serious damage.**



7. If the watercraft will be stored for a week or more, lubricate internal engine components to help prevent corrosion. (See page 4-3 for lubrication procedures.)
8. Rinse the engine and engine compartment with a small amount of water.

**CAUTION:**

**Do not use high pressure when rinsing the engine or engine compartment as severe engine damage could result.**

9. Wipe the engine and engine compartment dry with a clean cloth (repeat step 3, if necessary).
10. Wipe the hull, handlebars, and jet unit dry with a clean cloth.
11. Spray a rust inhibitor on metallic parts to minimize corrosion.

**⚠WARNING**

**Do not spray flammable rust inhibitor products on engine surfaces while the engine is hot. The sprayed substance or propellants could catch fire.**

12. Allow the engine compartment to air dry completely before installing the seat.

**NOTE:**

Cover watercraft after engine and catalytic converter cool down.



EJU20090

## Transporting

When transporting the watercraft on a trailer, secure the tie downs to the trailer through the bow eye and stern rope holes.

**CAUTION:**

**Do not route ropes or tie downs over the seat, as they may leave permanent marks on the seat's surface. Also, wrap the ropes or tie downs with towels or rags where they touch the body of the watercraft to avoid scratching or damage.**

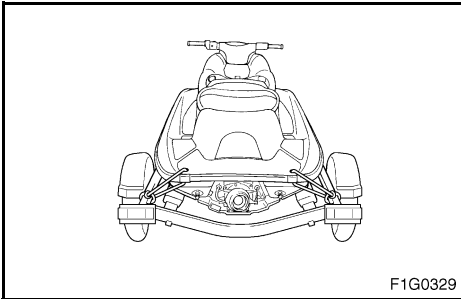
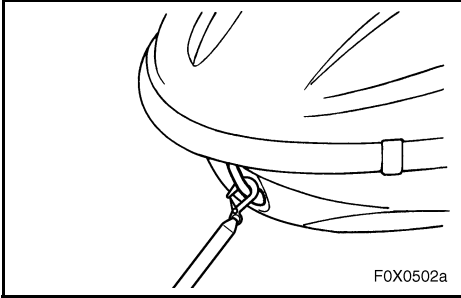

EJU10860

# MAINTENANCE AND CARE



<b>Storage</b> .....	4-1
Flushing the cooling system .....	4-1
Lubrication .....	4-3
Fuel system .....	4-3
Battery .....	4-5
Cleaning the watercraft .....	4-6
<b>Maintenance and adjustments</b> .....	4-7
Owner's/Operator's Manual and tool kit .....	4-8
Periodic maintenance chart .....	4-9
Inspecting the fuel system .....	4-10
Inspecting the oil injection system .....	4-11
Inspecting the jet thrust nozzle angle .....	4-12
Inspecting and adjusting the throttle cable .....	4-12
Inspecting the QSTS mechanism .....	4-13
Cleaning and adjusting the spark plugs .....	4-14
Lubrication points .....	4-15
Inspecting the battery .....	4-18
Adjusting the fuel injection system .....	4-20
Replacing the fuse .....	4-21
Bleeding the oil injection pump .....	4-21
Adjusting the Yamaha Adjustable Sponson (Y.A.S.) .....	4-22
<b>Specifications</b> .....	4-23



## Storage

### **⚠WARNING**

Always place the watercraft upright in a horizontal position when storing it, otherwise fuel could leak out into the engine or engine compartment, which could result in a fire hazard.

Storage for prolonged periods of time, such as winter storage, requires preventative maintenance to ensure against deterioration. It is advisable to have the watercraft serviced by a Yamaha dealer prior to storage. However, the following procedures can be performed by the owner.

EJU11940

### **Flushing the cooling system**

Flushing the cooling system is essential to prevent the cooling system from being clogged with salt, sand, or dirt.

### **⚠WARNING**

Stay away from stern when engine is running on land. Hot water and steam spurring from exhaust outlet into the air can cause serious burns.

### **CAUTION:**

- Do not supply water to the cooling water passages when the engine is not running. The water could flow back through the muffler into the crankcase causing severe engine damage.
- Do not run the engine for more 15 seconds without supplying water, otherwise the engine may overheat.
- Do not run engine over 4,000 r/min on land. The catalytic converter could sustain serious damage.

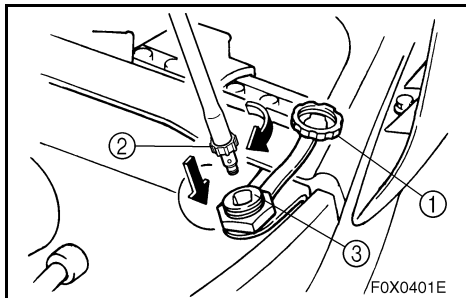

1. Put the watercraft on land in a horizontal position.
2. Open the flushing hose connector cap ①, and then insert the garden hose adapter ② into the flushing hose connector ③ and turn it until it is securely connected.
3. Connect the garden hose adapter to a water tap using a hose.
4. Start the engine, and then immediately turn the water supply on until water flows out continually from the cooling water pilot outlet.
5. Run the engine at idling speed for about 3 minutes watching the engine condition. If the engine stops while flushing, turn the water supply off immediately and repeat the above steps.
6. Turn the water supply off, and then force the remaining water out from the cooling passages by running the engine at 4,000 r/min or less within 10 to 15 seconds.
7. Stop the engine.
8. Remove the garden hose adapter and secure the cap.



EJU20100

## Lubrication

### **⚠WARNING**

**Do not spray flammable rust inhibitor products on engine surfaces while the engine is hot. The sprayed substance or propellants could catch fire.**

1. Remove the spark plugs and pour approximately one tablespoon of oil into each cylinder.
2. Grease the spark plug threads and reinstall the spark plugs.
3. Crank the engine within 3 seconds using the start switch.
4. Lubricate all cables such as the throttle and steering cables.

### **NOTE:**

Use a suitable marine grease applicator to pressure lubricate the cables and purge out any moisture between the inner and outer cables.

5. Lubricate the areas of the watercraft specified under Lubrication points on page 4-15.

EJU20221

## Fuel system

### **⚠WARNING**

**GASOLINE AND ITS VAPORS ARE HIGHLY FLAMMABLE AND EXPLOSIVE!**

- Do not smoke when refueling, and keep away from sparks, flames, or other sources of ignition.
- Stop engine before refueling.
- Refuel in a well-ventilated area with the watercraft in a horizontal position.
- Do not stand or sit on the watercraft while refueling in case of fire.





- Take care not to spill gasoline. If gasoline spills, wipe it up immediately with dry rags. Always properly dispose of gasoline-soaked rags.
- Avoid overfilling the fuel tank. Stop filling when the fuel level just reaches the bottom of the filler tube. Do not fill up the filler tube because fuel expands as it warms up and could overflow. If temporarily leaving the watercraft with a full fuel tank, do not leave it in direct sunlight. Leave it in a well-ventilated area with the watercraft in a horizontal position.
- Tighten the filler cap securely after refueling.
- If you should swallow some gasoline, inhale a lot of gasoline vapor, or get gasoline in your eyes, get immediate medical attention.
- If any gasoline spills onto your skin, immediately wash with soap and water. Change clothing if gasoline spills on it.

---

Fill the fuel tank with fresh gasoline and add 470 ml (15.9 US oz, 16.5 Imp oz) of Yamaha Fuel Stabilizer and Conditioner.

Recommended fuel stabilizer: Yamaha Fuel Stabilizer and Conditioner
---

**CAUTION:**

**Use only Yamaha Fuel Stabilizer and Conditioner. Using another stabilizer can damage the catalytic converter.**

---



EJU19700

## Battery

If the watercraft will not be used for more than a month, disconnect the negative (-) lead first, then the positive (+) lead and breather hose, and then remove the battery from the watercraft.

Clean the battery casing using fresh water.

If the battery terminals are dirty or corroded, clean them with a wire brush.

Fully charge the battery, and then store it in a cool, dark place.

Apply Yamaha marine grease or Yamaha grease A to the battery terminals.

Check the battery at least every 2 months and fully charge it if necessary.

### **⚠WARNING**

**Be sure to connect the breather hose to the battery. Fire or explosion could result if the breather hose is damaged, obstructed, or not connected properly.**

### **CAUTION:**

**The battery may not be usable again if you store it for a long period without charging it. Charge the battery periodically.**

**NOTE:** \_\_\_\_\_

The condition of the battery can be known by checking the specific gravity of the electrolyte. However, you can also know the condition of the battery by measuring the voltage at both battery terminals. Charge the battery if the voltage is less than 12 volts.

Specific gravity (for reference): 1.28 at 20 °C (68 °F)
--

It is recommended to have a Yamaha dealer check the specific gravity and to charge the battery. If you maintain the battery yourself, be sure to read and follow the instructions provided with the battery tester and charger you use.

EJU18800

## Cleaning the watercraft

Clean the watercraft before storing it for a long period.

**⚠WARNING** \_\_\_\_\_

**Do not spray flammable rust inhibitor products on engine surfaces while the engine is hot. The sprayed substance or propellants could catch fire.**

1. Wash down the hull, handlebars, and drive unit with fresh water.
2. Rinse the engine and bilge area with fresh water. Drain off all water and wipe up remaining moisture with clean, dry rags.
3. Spray the engine's exterior with a rust inhibitor or lubricant.
4. Wax the hull with a non-abrasive wax.
5. Wipe all vinyl and rubber components, such as the seat and engine compartment seals, with a vinyl protectant.



## Maintenance and adjustments

Periodic inspection, adjustment and lubrication will keep your watercraft in the safest and most efficient condition possible. Safety is an obligation of the watercraft owner. The most important points of watercraft inspection, adjustment and lubrication are explained on the following pages.

See your Yamaha dealer for genuine Yamaha replacement parts and optional accessories designed for your watercraft.

Remember that failures that are the result of the installation of parts or accessories which are not qualitatively equivalent to genuine Yamaha parts are not covered by the limited warranty.

### **⚠ WARNING**

- **Be sure to turn off the engine when you perform maintenance unless otherwise specified, otherwise an accident or injury could result from unexpected operation, moving parts, or electric shock. If the owner is not familiar with watercraft servicing, this work should be done by a Yamaha dealer. Improperly serviced components could fail or stop operating correctly, which could result in an accident.**
- **Modifications to this watercraft not approved by Yamaha may cause loss of performance or excessive noise, or render it unsafe for use. Consult a Yamaha dealer before attempting any changes.**

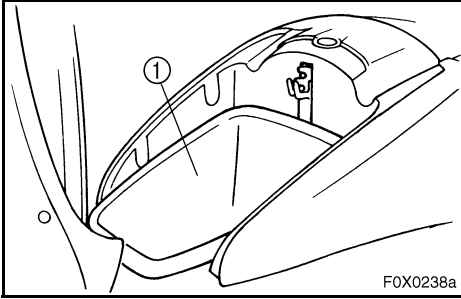

EJU18750

## Owner's/Operator's Manual and tool kit

It is advisable always to carry the Owner's/Operator's Manual and tool kit ② with you whenever you use the watercraft. For your convenience, a storage compartment ① is provided on the watercraft for the manual and tool kit.

**NOTE:**

To protect these materials from water damage, it would be a good idea to put them in a waterproof bag.

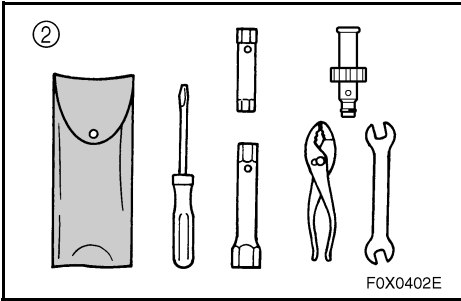

The service information included in this manual is intended to provide you with the necessary information for completing your own preventive maintenance and minor repairs. The tools provided in the tool kit are sufficient for this purpose.



EJU13550

## Periodic maintenance chart

The following chart gives general guidelines for periodic maintenance. However, depending on your operating conditions maintenance may need to be performed more frequently.

- This mark indicates maintenance that you may do yourself.
- This mark indicates work to be done by a Yamaha dealer.

MAINTENANCE INTERVAL  ITEM		INITIAL			THEREAFTER EVERY		PAGE
		10 hours	50 hours	100 hours	100 hours	200 hours	
			6 months	12 months	12 months	24 months	
Spark plug	Inspect, clean, adjust	●		●	●		4-14
Lubrication points	Lubricate			●	●		4-15
Intermediate housing	Lubricate	○*1		●*2	●*2		4-17
Fuel system	Inspect			○	○		4-10
Fuel tank	Clean					○	4-10
Oil injection system	Inspect, clean	○				○	4-11
Throttle shaft	Inspect			○	○		—
Cooling water passages	Flush	●*3					4-1
Water inlet strainer	Inspect, clean			○	○		—
Bilge strainer	Clean			○	○		—
Electric bilge pump strainer	Inspect, clean			○	○		—
Impeller	Inspect	●*4		○	○		—
Jet thrust nozzle angle	Inspect			●	●		4-12
QSTS mechanism	Inspect, adjust	●*4		○	○		4-13
Throttle lever	Check operation	●*4					3-11
Throttle cable	Inspect, adjust			○	○		4-12
Stern drain plugs	Inspect, replace	●*4		○	○		3-8
Battery	Inspect	●*5		○	○		4-18
Rubber coupling	Inspect					○	—
Engine mount	Inspect					○	—
Nuts and bolts	Inspect	○		○	○		—

\*1: Grease capacity: 33.0–35.0 cm<sup>3</sup> (1.11–1.18 oz)

\*2: Grease capacity: 6.0–8.0 cm<sup>3</sup> (0.20–0.27 oz)

\*3: After every use

\*4: Before every use

\*5: Inspect fluid level before every use



EJU18160

## Inspecting the fuel system

### **⚠ WARNING**

Gasoline is highly flammable and explosive. Failure to check for and repair any fuel leakage could result in fire or explosion. A fire or explosion can cause severe injury or death. Shut off the engine. Do not smoke. Avoid spilling gasoline.

Fuel in hose is pressurized.

Fuel can spray out and cause injury or a fire hazard if fuel line is disconnected.

Do not attempt to run engine with fuel line disconnected.

Check the fuel system for leaks, cracks, or malfunctions. If any problem is found, consult a Yamaha dealer.

#### **Check:**

- Fuel tank for water or dirt.
- Fuel tank cap (seal) for damage.
- Fuel tank for damage, cracks or leakage.
- Fuel hose joint for leakage.
- Fuel hose for cracks or other damage.
- Air bleeding passages for leakage.

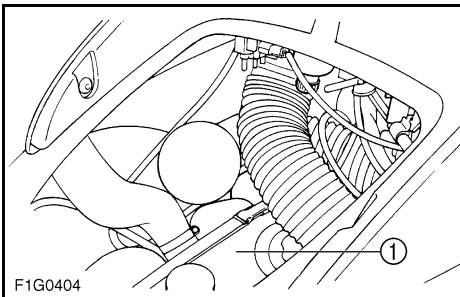

EJU18410

### **Fuel tank**

Check the fuel tank ① for leakage or water in the tank. If water is found in the fuel system or if the fuel tank needs to be cleaned, have a Yamaha dealer service the watercraft.



EJU11000

## Inspecting the oil injection system

Check the oil injection system for leakage, cracks, or malfunctions. If necessary, have a Yamaha dealer repair the oil injection system.

### Check:

- Oil tank for damage, cracks or leakage.
- Oil tank for water or dirt.
- Oil hose and joint for damage or cracks.
- Oil filter for dirt.
- Oil pump for leakage.

EJU11010

### Oil tank

Check the oil tank for leakage or water in the tank. If water is found in the oil injection system or if the oil tank needs to be cleaned have a Yamaha dealer service the watercraft.

EJU20230

### Oil filter

Have a Yamaha dealer check the oil filter for dirt and clogs.



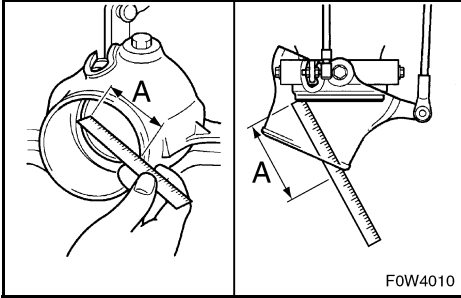

EJU18890

## Inspecting the jet thrust nozzle angle

Check for smooth operation of the handlebars and jet thrust nozzle.

Turn the handlebars as far as possible to the right and left and check that the difference of distance A and B between the jet thrust nozzle and the nozzle is within 5 mm.

Difference of A and B:  
Maximum 5 mm (0.20 in)

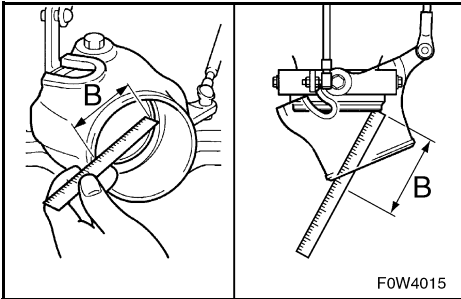

EJU11040

## Inspecting and adjusting the throttle cable

Check that the throttle cable moves back to the set position smoothly and that free play is within specification.

1. Squeeze and release the throttle lever. If the lever does not return smoothly, have a Yamaha dealer service it.
2. Adjust free play  $\textcircled{a}$  by loosening the lock-nut  $\textcircled{1}$  and turning the adjuster  $\textcircled{2}$ .

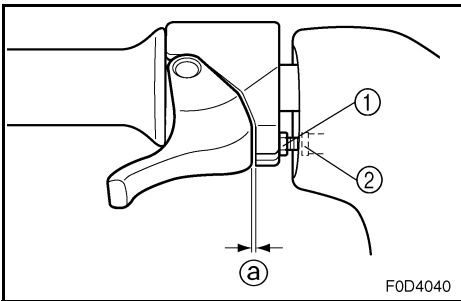

Throttle lever free play:  
4–7 mm (0.16–0.28 in)



EJU18420

## Inspecting the QSTS mechanism

Check that the shift lock lever moves back to the lock position smoothly, that the QSTS selector locks and unlocks properly, and that the jet thrust nozzle moves up or down.

1. Squeeze and release the shift lock lever.
2. Check that the QSTS selector locks and unlocks when the lever is released.
3. Check that the selector turns smoothly when the lever is squeezed and held in place.
4. Check that the angle of the jet thrust nozzle changes when the selector is shifted from neutral to bow up or bow down.

If the mechanism does not work properly, have a Yamaha dealer service it.

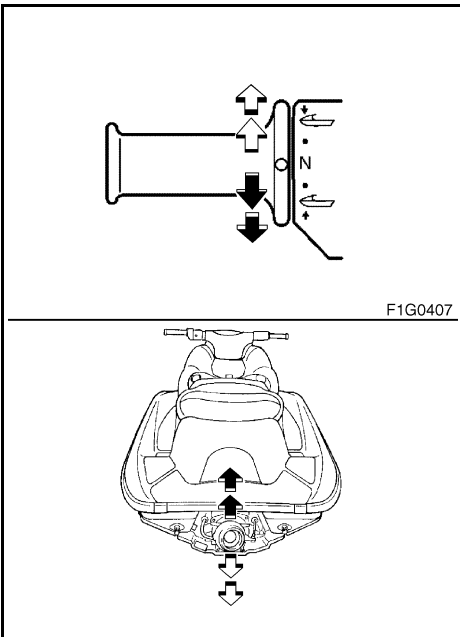
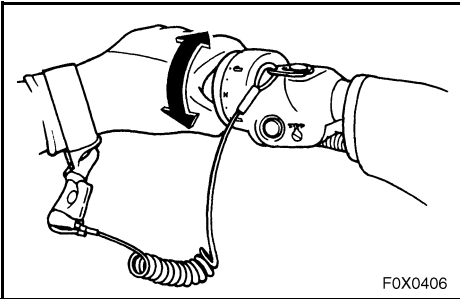
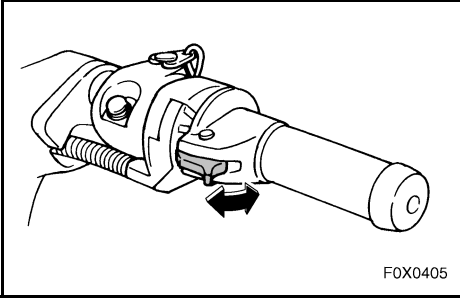



EJU11061

## Cleaning and adjusting the spark plugs

The spark plug is an important engine component and is easy to inspect. The condition of the spark plug can indicate something about the condition of the engine. For example, if the center electrode porcelain is very white, this could indicate an intake air leak or carburetion problem in that cylinder. Do not attempt to diagnose any problems yourself. Have a Yamaha dealer service the watercraft.

Remove and inspect the spark plug periodically; heat and deposits will cause the spark plug to slowly break down and erode. If electrode erosion becomes excessive, or if carbon and other deposits are excessive, replace the spark plug with the specified plug.

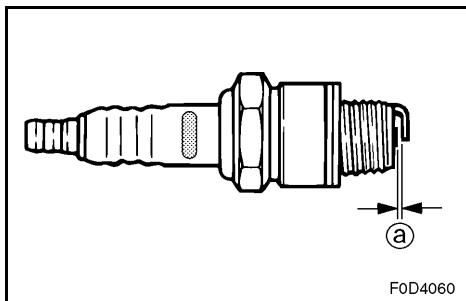

Standard spark plug: BR8ES-11

Measure the spark plug gap  $\text{\textcircled{a}}$  with a wire thickness gauge before installing the spark plug. Replace the spark plugs or adjust the gap to specification if necessary.

Spark plug gap:  
1.0–1.1 mm (0.039–0.043 in)

### To install the spark plug:

1. Clean the gasket surface.
2. Wipe any dirt from the threads of the spark plug.
3. Screw the spark plug to the correct torque.

Spark plug tightening torque:  
25 N·m (2.5 kgf·m, 18 ft·lb)

**NOTE:**

- Wipe off any water on the spark plug or inside the cap before installing the spark plug cap. Push the spark plug cap down until it clicks.
- If a torque wrench is not available when you are fitting a new spark plug, a good estimate of the correct torque is 1/4 turn to 1/2 turn past finger tight. Have the spark plug adjusted to the correct torque with a torque wrench as soon as possible.

**⚠WARNING**

**Be careful not to damage the insulator when removing or installing a spark plug. A damaged insulator could allow sparks to escape, which could lead to explosion or fire.**

EJU20111

**Lubrication points**

To keep moving parts sliding or rotating smoothly, coat them with water-resistant grease.

Recommended water resistant grease:  
Yamaha Marine Grease/  
Yamaha Grease A

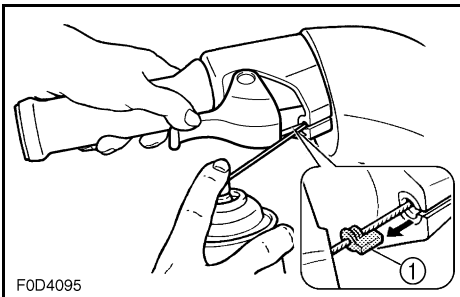

- Throttle cable (handlebar end)  
Pull the throttle lever and remove the seal ①. Spray a rust inhibitor into the outer cable. Refit the seal securely.

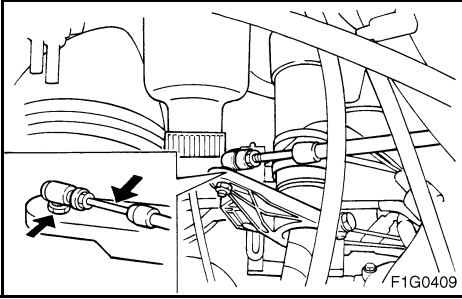

- Steering cable (handlebar end)

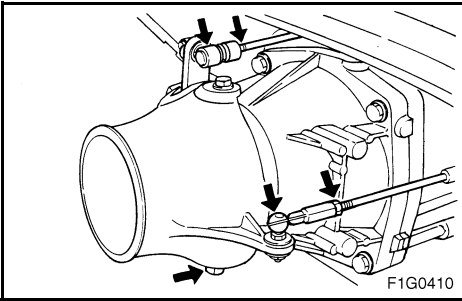

- Steering cable (nozzle end)
- Nozzle pivot shaft
- QSTS cable (nozzle end)

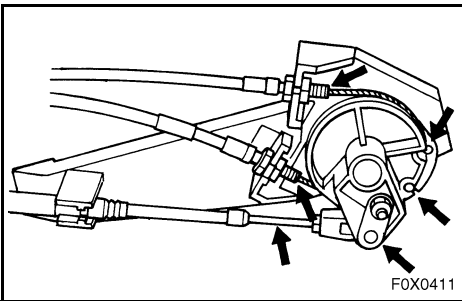

- QSTS cables (pulley end)

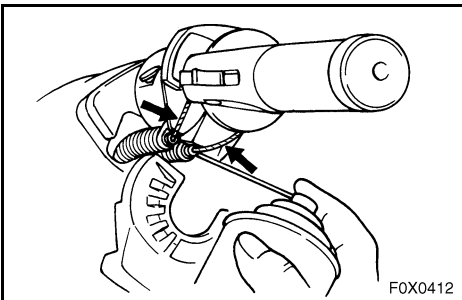

- QSTS cables (handlebar end)  
Remove the QSTS cable housing. Spray a rust inhibitor into the outer cable. Reinstall the QSTS cable housing.

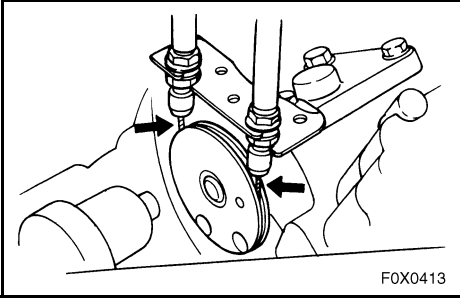

- YPVS cable  
Spray the rust inhibitor into the outer cable.

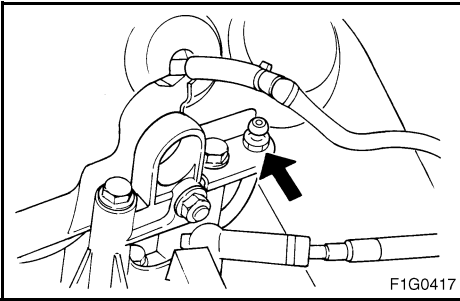

- Intermediate housing  
Using a grease gun, fill the intermediate housing with water-resistant grease through the grease nipple.

Grease capacity:  
Initial 10 hours or 1 month:  
33.0–35.0 cm<sup>3</sup> (1.11–1.18 oz)  
Every 100 hours or 12 months:  
6.0–8.0 cm<sup>3</sup> (0.20–0.27 oz)



EJU19710

## Inspecting the battery

Check the level of the battery electrolyte and make sure that the negative and positive leads are securely tightened.

### **⚠ WARNING**

- **Battery electrolyte is poisonous and dangerous, causing severe burns, etc. Electrolyte contains sulfuric acid. Avoid contact with skin, eyes, or clothing.**

#### **Antidotes**

**External: Flush with water.**

**Internal: Drink large quantities of water or milk. Follow with milk of magnesia, beaten egg, or vegetable oil. Call physician immediately.**

**Eyes: Flush with water for 15 minutes and get prompt medical attention.**

**Batteries produce explosive gases. Keep sparks, flame, cigarettes, etc., well away. If using or charging the battery in an enclosed space, make sure that it is well ventilated. Always shield your eyes when working near batteries.**

**KEEP OUT OF THE REACH OF CHILDREN.**

- **Be sure to connect the breather hose to the battery. Fire or explosion could result if the breather hose is damaged, obstructed, or not connected properly.**

### **CAUTION:**

- **Be careful not to place the battery on its side.**
- **Be sure to remove the battery from the battery compartment when adding electrolyte or charging the battery.**

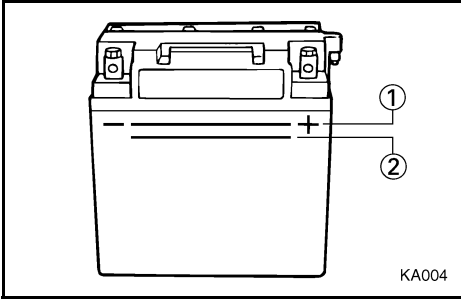
**To replenish the battery:**

1. Make sure that the electrolyte level is between the upper ① and lower ② level marks.
2. Refill the battery with distilled water if necessary.

**CAUTION:**

**Normal tap water contains minerals that are harmful to a battery. Use only distilled water for replenishing the battery.**

**To recharge the battery:****CAUTION:**

**Do not attempt to charge a battery hastily. Battery life could be shortened.**

It is recommended to have a Yamaha dealer charge the battery. If you charge the battery yourself, carefully read the battery charger instructions before charging and follow the points below.

1. Remove all caps from the battery cell.
2. Add distilled water to the specified level if the electrolyte level is low.
3. Set the charging rate to 1.9 ampere and charge the battery slowly until the explosive gases are discharged vigorously from the battery cells.

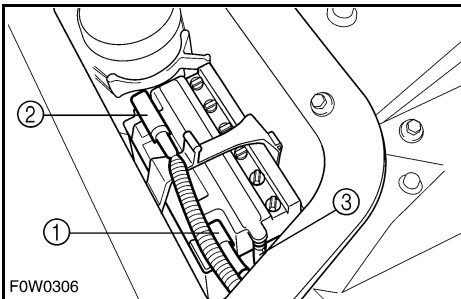
**To connect the battery terminals:**

1. Make sure that the connections are correct when you install the battery in the watercraft.
2. Make sure that the breather hose is properly connected and that it is not damaged or obstructed.
3. Make sure that the battery is securely held in place.

- ① Positive (+): Red lead
- ② Negative (-): Black lead
- ③ Breather hose





EJU18231

## Adjusting the fuel injection system

The fuel injection system was set at the Yamaha factory. Have a Yamaha dealer service the watercraft if necessary.

### **CAUTION:**

**Do not attempt to adjust the fuel injection system. If the settings are changed poor engine performance and damage may result.**

EJU20240

## Checking the trolling speed

1. Put the watercraft in the water.
2. Start the engine and warm it up. Use the tachometer in the multifunction information center to check the trolling speed.

Trolling speed: 1,250–1,450 r/min

If the trolling speed is out of specification, have a Yamaha dealer service the watercraft.

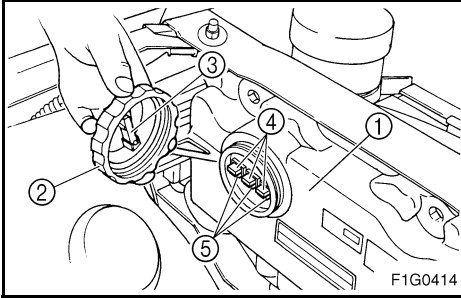

EJU18250

## Replacing the fuse

The fuse is in the electrical box ①.

### To replace the fuse:

1. Remove the cap ②.
2. Replace the fuse ④ with the spare fuse ⑤ of the correct amperage by using the special tool ③ on the reverse side of the cap.

Fuse amperage:

20 A (main)

3 A (meter)

3 A (bilge pump)

### **⚠WARNING**

**Do not use fuses of higher amperage than those recommended. Substitution of a fuse of improper rating can cause extensive electrical system damage and possible fire.**

EJU11120

## Bleeding the oil injection pump

If the oil tank becomes completely empty, or any hose connected to the oil pump has been disconnected, the oil pump must be bled to ensure proper oil flow.

If bleeding of the oil pump is necessary, have a Yamaha dealer bleed it.

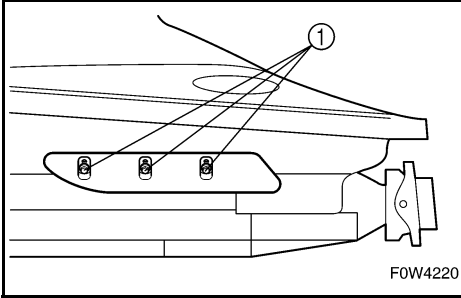

EJU11130

## Adjusting the Yamaha Adjustable Sponson (Y.A.S.)

The Yamaha Adjustable Sponsons can be adjusted to enhance watercraft performance according to operator preference and operating conditions. (See page 2-21 for an explanation of various positions.)

### To adjust the Y.A.S.:

1. Remove the bolts ① on both sponsons.
2. Remove both sponsons, and then install them in the desired position.

### NOTE:

Be sure to install both sponsons to the same level.

3. Tighten the bolts on both sponsons to the correct torque.

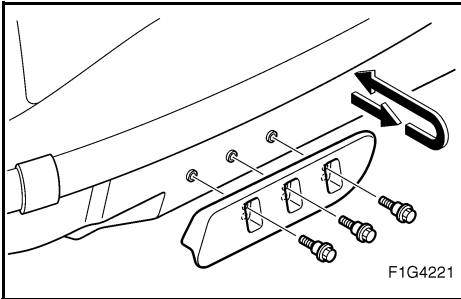

Tightening torque:

18 N·m (1.8 kgf·m, 13 ft·lb)



EJU13590

## Specifications

	MODEL	Unit	GP1300R
<b>WATERCRAFT CAPACITY</b>			
Maximum people on board		Number of people	2
Maximum load capacity		kg (lb)	160 (353)
<b>DIMENSIONS</b>			
Length		mm (in)	2,930 (115.4)
Width		mm (in)	1,150 (45.3)
Height		mm (in)	1,020 (40.2)
Dry weight		kg (lb)	297 (653)
<b>PERFORMANCE</b>			
Maximum output		kW (PS) @ r/min	121.4 (165) @ 7,000
Maximum fuel consumption		L/h (US gal/h, Imp gal/h)	63.0 (16.6, 13.9)
Cruising range at full throttle		hr.	1.0
Trolling speed		r/min	1,250–1,450
<b>ENGINE</b>			
Engine type			2-stroke
Number of cylinders			3
Engine displacement		cm <sup>3</sup> (cu in)	1,297 (79.1)
Bore & stroke		mm (in)	84 × 78 (3.31 × 3.07)
Compression ratio			5.9:1
Lubrication system			Variable oil injection
Cooling system			Water cooled
Starting system			Electric starter
Ignition system			Digital CDI
Spark plug			BR8ES-11 (NGK)
Spark plug gap		mm (in)	1.0–1.1 (0.039–0.043)
Battery capacity		V-AH	12-19
Charging system			Flywheel magneto
<b>DRIVE UNIT</b>			
Propulsion system			Jet pump
Jet pump type			Axial flow, single stage
Impeller rotation			Counterclockwise (viewed from rear)
Transmission			Direct drive from engine
Jet thrust nozzle angle		Degree	23 + 23
Trim nozzle angle		Degree	-5, 0, 5, 10, 15
<b>FUEL AND OIL</b>			
Recommended fuel			Regular unleaded gasoline
Minimum octane rating		PON	86
		RON	90
Recommended engine oil			YAMALUBE 2-W only
Fuel tank capacity			
Total		L (US gal, Imp gal)	60 (15.9, 13.2)
Oil tank capacity		L (US gal, Imp gal)	5.5 (1.5, 1.2)

EJU11150

# TROUBLESHOOTING AND EMERGENCY PROCEDURES

<b>Troubleshooting</b> .....	5-1
Troubleshooting chart .....	5-1
<b>Emergency procedures</b> .....	5-4
Cleaning the jet intake and impeller .....	5-4
Jumping the battery .....	5-5
Towing the watercraft .....	5-7
Submerged watercraft .....	5-8





EJU11160

# Troubleshooting

If you have any trouble with your watercraft, use this section to check for the possible cause.

If you cannot find the cause, or if the procedure for replacement or repair is not described in this Owner's/Operator's Manual, have a Yamaha dealer perform the necessary service.

EJU13670

## Troubleshooting chart

TROUBLE	POSSIBLE CAUSE		REMEDY	PAGE
<b>Engine does not start</b>	<b>Starter motor does not turn over</b>			
	Engine shut-off switch	Clip not in place	Install clip	2-7
	Fuse	Burned out	Replace the fuse and check wiring	4-21
	Battery	Run down	Recharge	4-18
		Poor terminal connections	Tighten as required	4-18
		Terminal corroded	Clean	—
	Starter motor	Faulty	Have serviced by Yamaha dealer	—
	Warning system	Overheat mode	Cool down engine	2-12
	<b>Starter motor turns over</b>			
	Throttle lever	Squeezed	Release	2-7
	Fuel	Empty	Refill as soon as possible	3-4
		Stale or contaminated	Have serviced by Yamaha dealer	4-10
	Fuel tank	Water or dirt present	Have serviced by Yamaha dealer	4-10
	Spark plug	Fouled or defective	Clean or replace	4-14
	Spark plug cap	Not connected or loose	Connect properly	4-14
	Crankcase	Filled with water	Crank engine with plug out until clean	5-8
Fuel injection system	Fuel pump faulty	Have serviced by Yamaha dealer	—	
Water temperature sensor	Failed	Have serviced by Yamaha dealer	2-12	



TROUBLE	POSSIBLE CAUSE		REMEDY	PAGE
<b>Engine runs irregularly or stalls</b>	Fuel	Empty	Refill as soon as possible	3-4
		Stale or contaminated	Have serviced by Yamaha dealer	4-10
	Fuel tank	Water or dirt present	Have serviced by Yamaha dealer	4-10
	Spark plug	Fouled or defective	Replace	4-14
		Incorrect heat range	Replace	4-14
		Gap incorrect	Adjust	4-14
	Spark plug cap	Loose	Connect properly	4-14
		Cracked, torn, or damaged	Replace	—
	Electrical wiring	Loose connection	Tighten or connect properly	—
Fuel injection system	Faulty or clogged injectors	Have serviced by Yamaha dealer	—	
<b>Warning light or indicator blinks</b>	Fuel level	Empty	Refill as soon as possible	3-4
	Engine oil level	Empty	Refill immediately	3-5
		Oil filter clogged	Have serviced by Yamaha dealer	—
	Engine overheated	Jet intake clogged	Clean	5-4
		Water temperature sensor is failed	Have serviced by Yamaha dealer	2-12
	Low battery voltage	Battery voltage low	Charge	4-18
		Battery terminal connected wrong	Connect properly	4-18
	Exhaust gas temperature	Gas temperature is too high	Cool down engine	2-13
Check engine warning	Faulty sensors	Have serviced by Yamaha dealer	—	



TROUBLE	POSSIBLE CAUSE		REMEDY	PAGE
<b>Watercraft slow or loses power</b>	Cavitation	Jet intake clogged	Clean	5-4
		Impeller damaged or worn	Have serviced by Yamaha dealer	—
	Engine overheated	Jet intake clogged	Clean	5-4
	Spark plug	Fouled or defective	Replace	4-14
		Incorrect heat range	Replace	4-14
		Gap incorrect	Adjust	4-14
	Spark plug caps	Loose	Connect properly	4-14
	Electrical wiring	Loose connection	Tighten or connect properly	—
	Fuel	Stale or contaminated	Have serviced by Yamaha dealer	4-10
	Bilge	Water in bilge	Drain	3-8



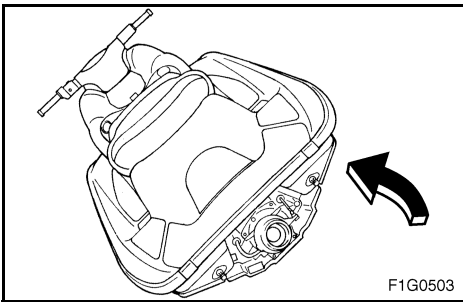
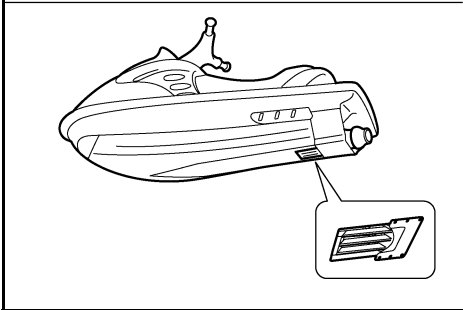
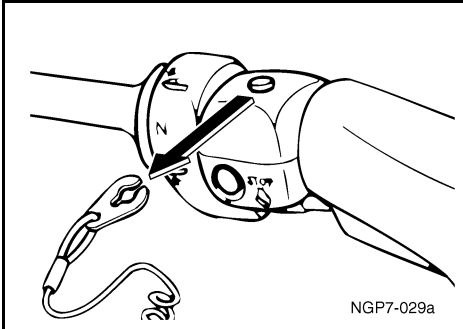

EJU11180

## Emergency procedures

EJU11190

### Cleaning the jet intake and impeller

If weeds or debris get caught in the intake or impeller, cavitation can occur, causing jet thrust to decrease even though engine speed rises. If this condition is allowed to continue, the engine will overheat and may seize. If there is any sign that the jet intake or impeller is clogged with weeds or debris, beach the watercraft and check the intake and impeller. Always stop the engine before beaching the watercraft.

#### **⚠WARNING**

Before attempting to remove weeds or debris from the jet intake or impeller areas, shut the engine off and remove the clip from the engine shut-off switch. Severe injury or death could result from contact with the rotating parts of the jet pump.

1. Turn the watercraft on its side as shown.

#### **CAUTION:**

- Place a suitable clean cloth or carpet underneath the watercraft to protect it from abrasions and scratches.
- Always turn the watercraft over onto its port (left) side.
- When turning the watercraft on its side, support the bow so the handlebars cannot be bent or damaged.



2. Remove any weeds or debris from around the drive shaft, impeller, pump housing, and jet thrust nozzle.  
If debris is difficult to remove, consult your Yamaha dealer.

**CAUTION:**

**Always avoid operating your watercraft in areas where weed growth is thick. If traveling in weeded areas is unavoidable, operate the engine alternately at partial throttle and full throttle. Weeds tend to accumulate more at a steady speed and at trolling speed. If weeds clog the intake or impeller area and cause cavitation, follow the cleaning procedure above.**

EJU18440

## Jumping the battery

If the watercraft battery has run down, the engine can be started using a 12-volt battery and jumper cables.

**⚠WARNING**

**Battery electrolyte is poisonous and dangerous, causing severe burns, etc. Electrolyte contains sulfuric acid. Avoid contact with skin, eyes or clothing.**

**Antidotes**

**External: Flush with water.**

**Internal: Drink large quantities of water or milk. Follow with milk of magnesia, beaten egg or vegetable oil. Call physician immediately.**

**Eyes: Flush with water for 15 minutes and get prompt medical attention.**

**Batteries produce explosive gases. Keep sparks, flame, cigarettes, etc. well away. If using or charging the battery in an enclosed space, make sure that it is well ventilated. Always shield your eyes when working near batteries.**

**KEEP OUT OF THE REACH OF CHILDREN.**

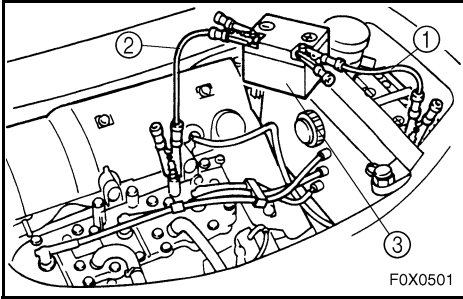

EJU18820

### Connecting the jumper cables

1. Connect the positive (+) jumper cable ① to the positive (+) terminals of both batteries.
2. Connect one end of the negative (-) jumper cable ② to the negative (-) terminal of the booster battery ③.
3. Connect the other end of the negative (-) cable to an unpainted bolt on the cylinder head.

**CAUTION:** \_\_\_\_\_

Do not connect the end of the jumper cable to the negative (-) terminal on the watercraft battery! Be sure all connections are secure and correct before attempting to start the engine. Any wrong connection may damage the electrical system.

4. Start the engine, and then disconnect the cables by reversing the steps above.

**CAUTION:** \_\_\_\_\_

- Never push the start switch while the engine is running.
- Do not operate the start switch for more than 5 seconds, otherwise the battery will be discharged and the engine will not start. Also, the starter motor may be damaged. If the engine does not start in 5 seconds, release the start switch, wait 15 seconds, and try again.



EJU19130

## Towing the watercraft

If the watercraft becomes inoperative in the water, it can be towed to shore.

If the watercraft must be towed in an emergency using a towline, the operator should ride the watercraft, holding onto the handlebars.

### CAUTION:

- Tow the watercraft at 5 mph (8 km/h) or less, otherwise water could enter the engine through the exhaust passages or through the air intake and flood the engine compartment if it is towed too fast.
- Tow the watercraft using the bow eye ① only.
- The bow must be kept up out of the water during towing to prevent water from entering the engine compartment.

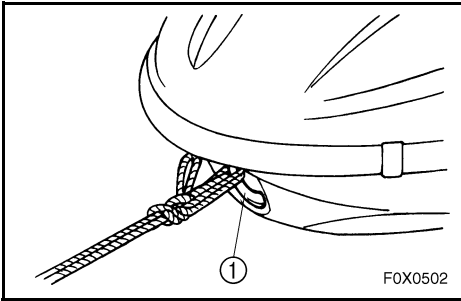

### ⚠WARNING

- The watercraft should only be towed in an emergency.
- The towline should be long enough so that the watercraft will not collide with the towing boat when slowing down. A good rule of thumb is a towline that is three times the combined length of the towing boat and the watercraft.
- The operator of the towing boat must keep speed to a minimum and avoid traffic or obstacles which could be a hazard to the rider on the watercraft.



EJU19020

## Submerged watercraft

If the watercraft is submerged or flooded with water, follow the procedure below and consult a Yamaha dealer as soon as possible. Failure to do so may result in serious engine damage!

### In an emergency:

1. Beach the watercraft and remove the stern drain plugs to drain the water from the engine compartment. (See page 3-8 for further instructions.)  
Remove the storage compartment plugs to drain the water from each storage compartment.
2. Install the stern drain plugs.
3. Have the watercraft inspected by a Yamaha dealer as soon as possible.



-MEMO-

EJU11240

# APPENDIX

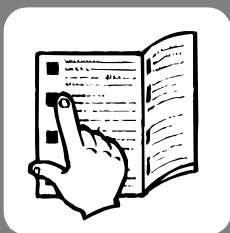

Index.....6-1



# Index

2-stroke engine oil ..... 3-3

## A

Adjusting the fuel injection system ..... 4-20

Adjusting the Yamaha Adjustable

Sponson (Y.A.S.) ..... 4-22

Approval label of Emission control  
certificate ..... 1-2

## B

Battery ..... 3-9, 4-5

Beaching the watercraft ..... 3-30

Bilge ..... 3-8

Bleeding the oil injection pump ..... 4-21

Boarding alone ..... 3-23

Boarding and starting in deep water ..... 3-23

Boarding with a passenger ..... 3-24

Bow down ..... 2-11

Bow up ..... 2-11

## C

Capsized watercraft ..... 3-25

Check engine warning indicator ..... 2-18

Checking the trolling speed ..... 4-20

Cleaning and adjusting the  
spark plugs ..... 4-14

Cleaning the jet intake and impeller ..... 5-4

Cleaning the watercraft ..... 4-6

Connecting the jumper cables ..... 5-6

Cooling water pilot outlet ..... 2-8, 3-13

Cruising limitations ..... 1-10

## D

Docking the watercraft ..... 3-30

## E

Emergency procedures ..... 5-4

Emission control information  
(For Canada only) ..... 1-2

Engine break-in ..... 3-14

Engine compartment ..... 3-7

Engine overheat warning indicator ..... 2-19

Engine overheat warning system ..... 2-12

Engine serial number ..... 1-1

Engine shut-off cord (lanyard) ..... 3-12

Engine shut-off switch ..... 2-7

Engine stop switch ..... 2-7

Enjoy your watercraft responsibly ..... 1-16

Exhaust temperature warning  
indicator ..... 2-19

Exhaust temperature warning  
system ..... 2-13

## F

Filling the fuel tank ..... 3-4

Filling the oil tank ..... 3-5

Fire extinguisher ..... 3-10

Flushing the cooling system ..... 4-1

Front storage compartment ..... 2-20

Fuel and oil ..... 3-1

Fuel and oil systems ..... 3-7

Fuel meter ..... 2-16

Fuel system ..... 4-3

Fuel tank ..... 4-10

Fuel tank filler cap ..... 2-6

Fuel warning indicator ..... 2-17

## G

Gasohol ..... 3-3

Gasoline ..... 3-1

Getting to know your watercraft ..... 3-19

Glove compartment ..... 2-21

## H

Handgrip ..... 2-11

Hazard information ..... 1-14

Hood ..... 2-6

Hour meter/Voltmeter ..... 2-17

Hull Identification Number (HIN) ..... 1-1

## I

Identification numbers ..... 1-1

Important labels ..... 1-3

Inspecting and adjusting the  
throttle cable ..... 4-12

Inspecting the battery ..... 4-18

Inspecting the fuel system ..... 4-10

Inspecting the jet thrust nozzle angle ..... 4-12

Inspecting the oil injection system ..... 4-11

Inspecting the QSTS mechanism ..... 4-13





<b>J</b>		
Jet unit.....	3-12	
Jumping the battery.....	5-5	
<b>L</b>		
Label location.....	1-3	
Learning to operate your watercraft.....	3-19	
Leaving the watercraft.....	3-18	
Limitations on who may operate the watercraft.....	1-9	
Location of main components.....	2-1	
Lubrication.....	4-3	
Lubrication points.....	4-15	
<b>M</b>		
Maintenance and adjustments.....	4-7	
Manufactured date label.....	1-2	
Multifunction information center ...	2-15, 3-13	
<b>O</b>		
Oil filter.....	4-11	
Oil tank.....	4-11	
Oil tank filler cap.....	2-6	
Oil warning indicator.....	2-18	
Operating your watercraft.....	3-19	
Operation.....	3-14	
Operation of controls and other functions.....	2-5	
Operation requirements.....	1-11	
Other labels.....	1-7	
Owner's/Operator's Manual and tool kit.....	4-8	
<b>P</b>		
Periodic maintenance chart.....	4-9	
Post-operation checks.....	3-31	
Pre-operation check list.....	3-6	
Pre-operation check points.....	3-7	
Pre-operation checks.....	3-6	
Primary Identification (PRI-ID) number.....	1-1	
<b>Q</b>		
Quick Shift Trim System (QSTS) selector.....	2-10	
<b>R</b>		
Recommended equipment.....	1-13	
Replacing the fuse.....	4-21	
Riding watercraft with a passenger.....	3-20	
Rough water operation.....	3-30	
<b>S</b>		
Safe boating rules.....	1-16	
Safety information.....	1-9	
Seat.....	2-5	
Specifications.....	4-23	
Speedometer.....	2-16	
Starting and boarding in shallow water.....	3-22	
Starting from a dock.....	3-22	
Starting the engine.....	3-16	
Starting the watercraft.....	3-21	
Start switch.....	2-8	
Steering system.....	2-9, 3-11	
Stopping the engine.....	3-18	
Stopping the watercraft.....	3-29	
Storage.....	4-1	
Storage compartments.....	2-20	
Submerged watercraft.....	5-8	
Switches.....	3-13	
<b>T</b>		
Tachometer.....	2-16	
Throttle.....	3-11	
Throttle lever.....	2-7	
Towing the watercraft.....	5-7	
Transporting.....	3-33	
Troubleshooting.....	5-1	
Troubleshooting chart.....	5-1	
Turning the watercraft.....	3-27	
<b>W</b>		
Warning labels.....	1-4	
Watercraft characteristics.....	1-14	
Water separator.....	3-8	
<b>Y</b>		
Yamaha Adjustable Sponson (Y.A.S.).....	2-21	
Yamaha Engine Management System (YEMS).....	2-14	







Printed in USA  
Jan. 2003—1.3 × 1 CR  
**F1G-F8199-70**  
(E)

Printed on recycled paper