



**2002  
WaveRunner**

**XLT1200**

**WaveRunner**



**OWNER'S/OPERATOR'S  
MANUAL**

READ THIS MANUAL  
CAREFULLY BEFORE OPERATION!

**YAMAHA MOTOR CO., LTD.**  
F0V-F8199-71●



## To the owner/operator

Thank you for choosing a Yamaha watercraft.

This Owner's/Operator's Manual contains information you will need for proper operation, maintenance, and care. A thorough understanding of these simple instructions will help you to obtain maximum enjoyment from your new Yamaha. If you have any questions about the operation or maintenance of your watercraft, please consult a Yamaha dealer.

Because Yamaha has a policy of continuing product improvement, this product may not be exactly as described in this Owner's/Operator's Manual. Specifications are subject to change without notice.

This manual should be considered a permanent part of this watercraft and should remain with it even if the watercraft is subsequently sold.

EJU01204

### Important manual information:

In this manual, information of particular importance is distinguished in the following ways:



The Safety Alert Symbol means **ATTENTION! BECOME ALERT! YOUR SAFETY IS INVOLVED!**

### **!WARNING**

**Failure to follow WARNING instructions could result in severe injury or death to the machine operator, passengers, a bystander, or a person inspecting or repairing the watercraft.**

### **CAUTION:**

**A CAUTION indicates special precautions that must be taken to avoid damage to the watercraft.**

### **NOTE:**

A NOTE provides key information to make procedures easier or clearer.

EJU00991

**WaveRunner XLT1200  
OWNER'S/OPERATOR'S MANUAL  
©2001 by Yamaha Motor Co., Ltd.  
1st Edition, September 2001  
All rights reserved.  
Any reprinting or unauthorized use  
without the written permission of  
Yamaha Motor Co., Ltd.  
is expressly prohibited.  
Printed in USA**



# CONTENTS



## GENERAL AND SAFETY INFORMATION

**1**

## FEATURES AND FUNCTIONS

**2**

## OPERATION

**3**

## MAINTENANCE AND CARE

**4**

## TROUBLESHOOTING AND EMERGENCY PROCEDURES

**5**

## APPENDIX

**6**

**READ THIS OWNER'S/OPERATOR'S MANUAL CAREFULLY  
BEFORE OPERATING YOUR WATERCRAFT.**



# GENERAL AND SAFETY INFORMATION



<b>Identification numbers</b> .....	1-1
Primary Identification (PRI-ID) number .....	1-1
Hull Identification Number (HIN) .....	1-1
Engine serial number .....	1-1
<b>Important labels</b> .....	1-2
Label location .....	1-2
Warning labels .....	1-3
Caution labels .....	1-6
Other labels .....	1-7
<b>⚠ Safety information</b> .....	1-9
Limitations on who may operate the watercraft .....	1-9
Cruising limitations .....	1-10
Operation requirements .....	1-11
Recommended equipment .....	1-13
Hazard information .....	1-14
Watercraft characteristics .....	1-14
Water-skiing .....	1-15
<b>Safe boating rules</b> .....	1-17
<b>Enjoy your watercraft responsibly</b> .....	1-17



EJU00994

# Identification numbers

Record your Primary Identification (PRI-ID) number, Hull Identification Number (HIN) and engine serial number in the spaces provided, to assist you in ordering spare parts from a Yamaha dealer. Also record and keep these ID numbers in a separate place in case your watercraft is stolen.

EJU00995

## Primary Identification (PRI-ID) number

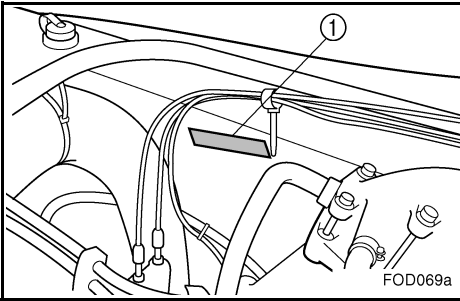

MODEL	XA1200A-A	PRI-ID	
		F0V	
YAMAHA MOTOR MANUFACTURING CORPORATION OF AMERICA ASSEMBLED IN U.S.A. FROM AMERICAN AND JAPANESE COMPONENTS. ASSEMBLÉ AUX ÉTATS-UNIS DE PIÈCES AMÉRICAINES ET JAPONAISES.			

F	0	V	-							
---	---	---	---	--	--	--	--	--	--	--

The PRI-ID number is stamped on a label ① attached to the inside of the engine compartment.

EJU01205

## Hull Identification Number (HIN)

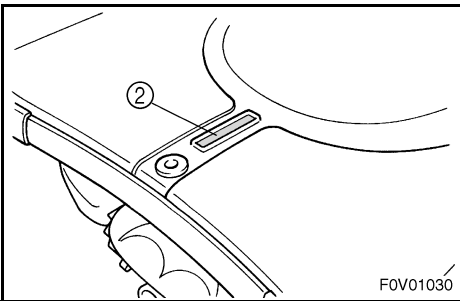

Y	A	M								
---	---	---	--	--	--	--	--	--	--	--

The HIN is stamped on a plate ② attached to the aft deck.

EJU00997

## Engine serial number

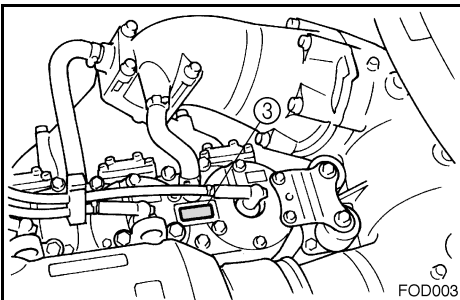

YAMAHA									
YAMAHA MOTOR CO., LTD. MADE IN JAPAN PAYÉ D'ORIGINE JAPON									

The engine serial number is stamped on a label ③ attached to the engine unit.





EJU00998

# Important labels

EJU01351

## Label location

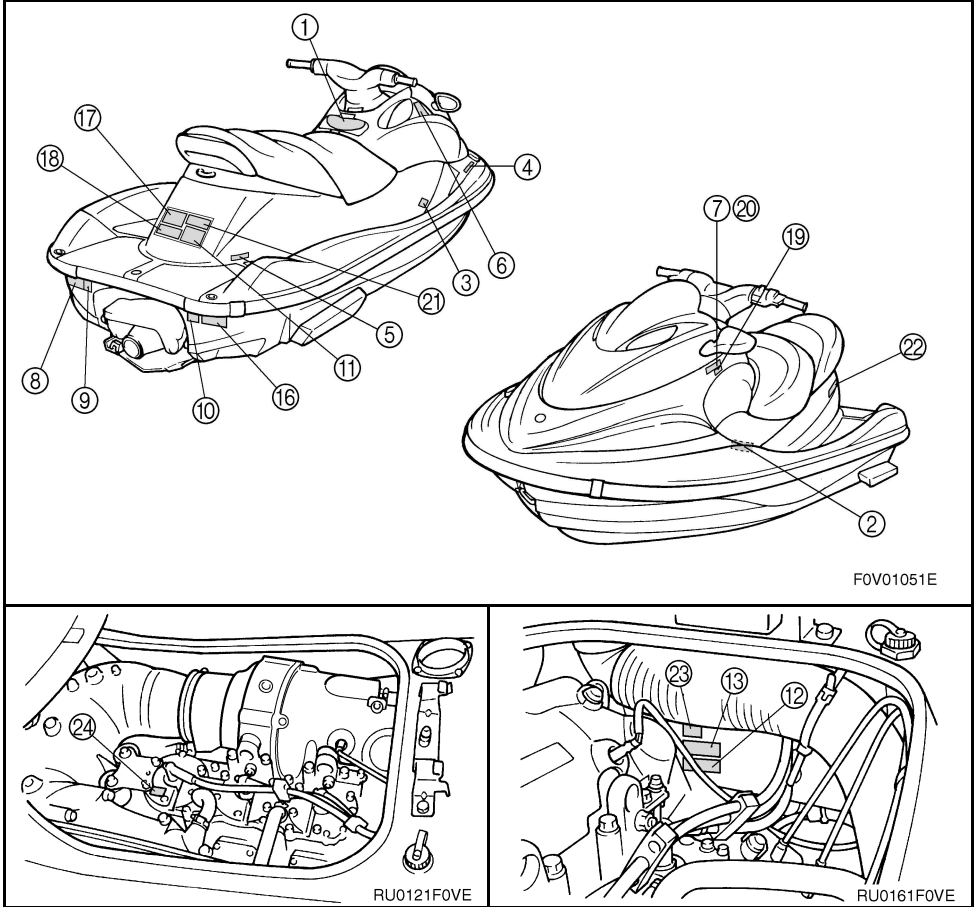

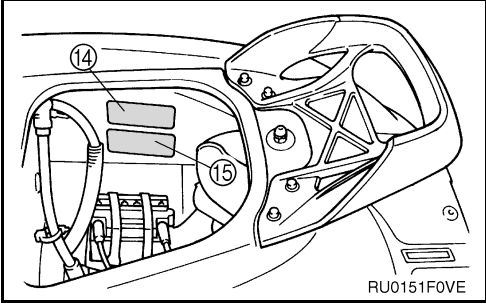

EJU01352

# Warning labels

1

**WEAR A PERSONAL FLOTATION DEVICE (PFD).** All riders must wear an authority-approved PFD that is suitable for personal watercraft (PWC) use.

**WEAR PROTECTIVE CLOTHING.** Severe internal injuries can occur if water is forced into body cavities as a result of falling into water or being near jet thrust nozzle. Normal swimmer does not adequately protect against forceful water entry into testicles or vagina. All riders must wear a wet suit bottom or bottom that provides equivalent protection (See Owner's Manual). Footwear, gloves, and goggles/glasses are recommended.

**KNOW BOATING LAWS.** Yamaha Motor Co., Ltd. recommends a minimum operator age of 16 years old. Know the operator age and training requirements for your state. A boating safety course is recommended and may be required in your state.

**ATTACH ENGINE SHUT-OFF CORD (LANYARD)** to wrist and keep it free from handlebars as that engine stops if operator falls off. After riding, remove cord from PWC to avoid unauthorized use by children or others.

**⚠ WARNING**

**To reduce the risk of SEVERE INJURY or DEATH:**

**RIDE WITHIN YOUR LIMITS AND AVOID AGGRESSIVE MANEUVERS** to reduce the risk of loss of control, ejection, and collision. This is a high performance boat – not a toy. Sharp turns or jumping wakes or waves can increase the risk of back/spinal injury (paralysis), facial injuries, and broken legs, ankles, and other bones. Do not jump wakes or waves.

**DO NOT APPLY THROTTLE WHEN ANYONE IS AT REAR OF PWC** – turn engine off or keep engine at idle. Water and/or debris exiting jet thrust nozzle can cause severe injury.

**KEEP AWAY FROM INTAKE GRATE** while engine is on. Items such as long hair, loose clothing, or PFD straps can become entangled in moving parts resulting in severe injury or drowning.

**NEVER RIDE AFTER CONSUMING DRUGS OR ALCOHOL.**



**PFD**  
**Wet Suit Bottom**

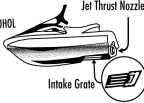

**Jet Thrust Nozzle**  
**Intake Grate**

**⚠ WARNING**

Collisions result in more **INJURIES AND DEATHS** than any other type of accident for personal watercraft (PWC).

**TO AVOID COLLISIONS: SCAN CONSTANTLY** for people, objects, and other watercraft. Be alert for conditions that limit your visibility or block your vision at others.

**OPERATE DEFENSIVELY** at safe speeds and keep a safe distance away from people, objects, and other watercraft.

- Do not follow directly behind PWCs or other boats.
- Do not go near others to spray or splash them with water.
- Avoid sharp turns or other maneuvers that make it hard for others to avoid you or understand where you are going.
- Avoid areas with submerged objects or shallow water.

**TAKE EARLY ACTION** to avoid collisions. Remember, PWC and other boats do not have brakes.

**DO NOT RELEASE THROTTLE WHEN TRYING TO STEER** away from objects – you need throttle to steer. Always check throttle and steering controls for proper operation before starting PWC. Follow navigation rules and state/province and local laws that apply to PWCs. See Owner's Manual for more information.

READ AND FOLLOW OWNER'S MANUAL  
YAMAHA

FOV-U41B1-51



②

### ⚠ AVERTISSEMENT

Afin de limiter les risques de **BLESSURES GRAVES, voire MORTELLES**, PORTER UN GILET DE SAUVETAGE. Tout utilisateur doit porter un gilet de sauvetage homologué pour les scooters des mers. PORTER DES VÊTEMENTS PROTÉCTEURS. Le choc infligé par la pénétration forcée d'eau dans les orifices corporels lors d'une chute ou lors du contact avec le jet d'eau de la pompe risque de provoquer des lésions graves. Le port d'un simple maillot de bain ne constitue pas une protection adéquate contre la pénétration de l'eau dans le rectum et/ou le vagin. Tout utilisateur doit porter le pantalon d'une tenue de plongée ou tout autre vêtement offrant une protection semblable. (Voir le manuel d'utilisation.) Le port de chaussures, de gants et de lunettes est recommandé.

#### CONNAÎTRE LES LOIS DE NAVIGATION

La Yamaha Motor Co., Ltd. recommande la limite d'âge de pilotage de 16 ans. Vérifier l'âge du pilote ainsi que les exigences quant à l'âge prévues par la législation locale. Il est préférable, et parfois requis par certaines législations, de suivre un cours de sécurité maritime. ATTACHER LA LAMÈRE DE L'INTÉRRUPTEUR D'ARRÊT DU MOTEUR au poignet et l'éloigner du guidon afin que le moteur se coupe bien en cas de chute. Après utilisation, retirer la lamère du scooter afin de prévenir toute utilisation par des enfants ou des personnes non-autorisées.

YAMAHA



RESPECTER SES LIMITES ET ÉVITER LES MANŒUVRES BRUTES afin de limiter tout risque de perte de contrôle, d'éjection et de collision. Il s'agit d'un véhicule à hautes performances et pas d'un jouet. Des virées brusques ou le saut de sillages ou de vagues accroît le risque de blessures au dos, voire de paralysie, de blessures au visage et de fractures diverses. Ne jamais sauter des sillages ni des vagues. NE PAS JONNER DES GAZ LORSQUE QUELQUIN SE TROUVE DERRIÈRE LE VÉHICULE: couper le moteur ou laisser tourner au ralenti. Eau et/ou débris projetés par la pompe pourraient causer des blessures graves.

NE PAS S'APPROCHER DE LA GRILLE D'ADMISSION lorsque le moteur tourne. Cheveux longs, vêtements amples ou lanternes de gilet de sauvetage risquent d'être happés, ce qui pourrait provoquer des blessures, ou même une noyade.

NE JAMAIS PILOTER APRÈS AVOIR ABSORBÉ DE L'ALCOOL, DES DROGUES OU CERTAINS MÉDICAMENTS.

LIRE ET RESPECTER LES INSTRUCTIONS DONNÉES DANS LE MANUEL D'UTILISATION.

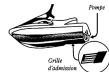

FOV-U41B1-60

③

### ⚠ AVERTISSEMENT

Les collisions sont la cause principale des **BLESSURES ET DÉCÈS** d'utilisateurs de scooter des mers.

#### POUR ÉVITER LES COLLISIONS:

**ÊTRE CONSTAMMENT** à l'affût de personnes, d'objets et d'autres bateaux. Être conscient des conditions limitant sa visibilité à celle des autres embarcations.

**PILOTER AVEC PRUDENCE** à des vitesses raisonnables et garder une distance de sécurité entre le scooter et toute personne, objet et embarcation.

- Ne pas suivre une autre embarcation de trop près.
- Ne pas se rapprocher d'autrui en vue de l'éclabousser.
- Éviter les virages brusques ou toute manœuvre qui risque de mettre un autre pilote en danger ou qui l'empêche de pouvoir déterminer clairement la direction que l'on prend.
- Éviter les endroits où flottent des objets et les eaux peu profondes.

**RÉAGIR RAPIDEMENT** en vue d'éviter les collisions. Garder à l'esprit que les bateaux s'ont pas de freins.

**NE PAS LÂCHER LES GAZ LORSQUE L'ON ESSAYE DE S'ÉLOIGNER** d'objets - une poussée est nécessaire à la direction du scooter des mers. Toujours s'assurer avant le départ que l'accélérateur et la direction fonctionnent correctement.

Suivre les lois de navigation ainsi que les législations nationales, provinciales et locales concernant les scooters des mers. Voir le manuel d'utilisation pour plus d'informations.

YAMAHA

FOH-U41B2-10



④

### ⚠ WARNING

Gasoline is highly flammable and explosive. A fire or explosion could cause severe injury or death. Shut engine off. Refuel in well ventilated area away from flames or sparks. Do not smoke. Avoid spilling gasoline. Wipe up spilled gasoline immediately. Remove all seats and front storage compartment to ventilate fuel vapors from engine compartment before starting engine. Do not start engine if there is a fuel leak or a loose electrical connection.

REGULAR UNLEADED GASOLINE ONLY

### ⚠ AVERTISSEMENT

L'essence est très inflammable et explosive. Un incendie ou une explosion risquent de provoquer des blessures graves, voire mortelles. Couper le moteur. Faire le plein dans un endroit bien aéré et éloigné de toute flamme ou étincelle. Ne pas fumer. Éviter de renverser de l'essence. Essayer immédiatement toute coulure d'essence. Déposer les selles et le compartiment de rangement avant pour évacuer les vapeurs d'essence du compartiment du moteur avant de mettre le moteur en marche. Ne jamais mettre le moteur en marche en cas de fuite d'essence ou si un branchement électrique est desserré.

ESSENCE NORMALE SANS PLOMB UNIQUEMENT

FOV-U415B-00

⑤

### ⚠ AVERTISSEMENT

APPLICABLE POUR LA FRANCE SEULEMENT

- En France : permis de conduire et immatriculation obligatoire.
- Navigation en mer autorisée entre 300 mètres et 1 mille nautique.
- Entre 0 et 300 mètres, se référer aux instructions nautiques locales affichées.

Si non, règle générale : vitesse maxi 5 noeuds (9 Km/h) dans cette zone.

- Utiliser les chevrons obligatoires de sortie lorsqu'ils existent.
- Respecter les règles de priorité.
- Gilet de sauvetage obligatoire-Fusée et bout de remorquage à bord.
- Ne jamais conduire sous l'influence de l'alcool ou de drogues.
- Consulter la météo avant de sortir en mer.
- Une conduite responsable et un contrôle quotidien de votre machine suivant le manuel d'entretien YAMAHA seront garantis de votre sécurité.

YAMAHA

G3-U41B1-00



6

**⚠ WARNING**  
REVERSE SHIFT LEVER OPERATION:

- Shift only while engine is idling or off.
- Reverse is for low speed maneuvering only.
- Do not use reverse function to slow down or stop PWC as it could cause you to lose control, be ejected, or impact handlebars.
- Make sure that there are no obstacles or people behind you before shifting to reverse.

**⚠ AVERTISSEMENT**

FONCTIONNEMENT DU LEVIER D'INVERSION DE MARCHE:

- Inverser la marche uniquement lorsque le moteur tourne au ralenti ou lorsqu'il est coupé.
- La marche arrière est destinée exclusivement aux manœuvres à vitesse réduite.
- Ne pas sélectionner la marche arrière en vue de ralentir ou d'arrêter le scooter des mers, car il y a risque de perte de contrôle, d'éjection ou de heurt sur le guidon.
- S'assurer qu'il n'y a ni obstacle ni personne derrière le scooter avant d'engager la marche arrière.

F0V-U41D5-30

7

**RECOMMENDED OIL**

YAMALUBE 2-W or an equivalent TC-W3 certified oil

**HUILE RECOMMANDEE**

Huile YAMALUBE 2-W ou une huile homologuée TC-W3 équivalente

YAMAHA

**⚠ WARNING**

Do not add gasoline to oil tank. Fire or explosion could result.

**⚠ AVERTISSEMENT**

Ne pas verser de l'essence dans le réservoir d'huile. Cela risquerait de provoquer un incendie ou une explosion.

F0M-U41E3-11

8

**⚠ WARNING**

IMPROPER UPRIGHTING CAN CAUSE INJURY.

- Shut engine off, and be sure engine shut-off cord is removed from engine shut-off switch.
- Do not put hand in intake grate.
- Make sure that you are not hit by PWC as it comes over.

TO TURN OVER:

- Pull PWC over with left hand on side plate while pushing down on gearcase with right hand/foot.

**⚠ AVERTISSEMENT**

UNE MAUVAISE TECHNIQUE DE REDRESSEMENT RISQUE D'ÊTRE LA CAUSE DE BLESSURES.

- Couper le moteur et s'assurer de retirer la tanière de l'interrupteur d'arrêt du moteur.
- Ne pas introduire la main dans la grille d'admission.
- Veiller à ne pas se cogner au scooter qui se redresse.

POUR REDRESSER:

- Faire basculer le scooter en plaçant la main gauche sur le pont et en appuyant sur le plat-bord à l'aide de la main droite ou du pied droit.

YAMAHA

F0P-U41D3-10

9

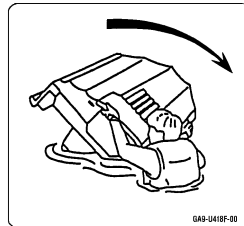

08B-U419F-00

10

**⚠ WARNING**

**⚠ AVERTISSEMENT**

Pinch hazard. Stay clear of reverse gate during operation.

Risque de pincement. Ne pas approcher la pelle d'inversion pendant son utilisation.

YAMAHA

F0P-U416R-10

11

**⚠ WARNING**

- Severe internal injuries can occur if water is forced into body cavities as a result of being near jet thrust nozzle.
- Wear a wetsuit bottom or clothing that provides equivalent protection.
- Do not board PWC if operator is applying throttle.

**⚠ AVERTISSEMENT**

- Le choc infligé par la pénétration forcée d'eau dans les orifices corporels lors du contact avec le jet de la pompe risque de provoquer des lésions graves.
- Porter le pantalon d'une tenue de plongée ou tout autre vêtement offrant une protection semblable.
- Ne pas embarquer lorsque le pilote donne des gaz.

(F0P-U41E1-21)



12

**WARNING**

Do not touch or remove electrical parts when starting or running the engine.

YAMAHA

6R7-83623-40

13

**AVERTISSEMENT**

Ne pas toucher ou retirer les pièces électriques lors du démarrage ou de la marche du moteur.

YAMAHA

6R7-83623-50

EJU01353

**Caution labels**

14

**CAUTION****BATTERY REMOVAL:**

- Disconnect both battery leads and battery breather hose before removing battery.

**BATTERY INSTALLATION:**

- Connect red lead to positive (+) terminal.
- Connect black lead to negative (-) terminal. Reversing leads will damage electrical system.
- Make sure that breather hose is connected after installation.

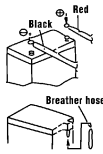

YAMAHA

70P-U418B-00

15

**ATTENTION****DÉPOSE DE LA BATTERIE:**

- Déconnecter les deux câbles et la durit de mise à l'air de la batterie avant de déposer celle-ci.

**REPOSE DE LA BATTERIE:**

- Connecter le câble rouge à la borne positive (+).
- Connecter le câble noir à la borne négative (-). L'inversion des câbles provoquera l'endommagement du système électrique.
- Après la repose, s'assurer que la durit de mise à l'air est correctement branchée.

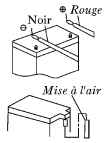

YAMAHA

FOP-U418B-10

16

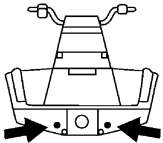
**CAUTION ATTENTION**

**BEFORE LAUNCHING:**  
See Owner's Manual for draining procedure. Make sure stern drain plugs are tightened securely.

**AVANT LE LANCEMENT:**  
Se référer au manuel d'utilisation pour procéder à la purge du scooter. S'assurer que les bouchons de purge à la poupe sont serrés correctement.

YAMAHA

FOP-U418G-10



17

**CAUTION****HANDGRIP IS FOR BOARDING AND SPOTTING ONLY.**

Do not use to tow objects, lift PWC, or attach tie downs, otherwise damage could occur.

**ATTENTION**

LA POIGNÉE EST DESTINÉE UNIQUEMENT À L'EMBARCATION ET À L'OBSERVATION.

*Ne pas utiliser pour remorquer, soulever ou amarrer le scooter, sous peine de l'endommager.*

(F0P-U41E1-21)

18

**CAUTION**

- Cleat is for mooring or pulling a water skier.
- Do not use cleat to lift PWC, otherwise damage could occur.

**ATTENTION**

- *Le taquet est destiné à l'amarrage et à la traction d'un skieur nautique.*
- *Ne pas utiliser le taquet afin de soulever le scooter, sous peine de l'endommager.*

(F0P-U41E1-21)

EJU01354

**Other labels**

19

**FIRE EXTINGUISHER CONTAINER  
COMPARTMENT DE L'EXTINCTEUR**

F0V-U41F5-10

20

**RECOMMENDED OIL**

**YAMALUBE 2-W or an equivalent TC-W3 certified oil**

**HUILE RECOMMANDÉE**

**Huile YAMALUBE 2-W ou une huile homologuée TC-W3 équivalente**

YAMAHA

**⚠ WARNING**

Do not add gasoline to oil tank. Fire or explosion could result.

**⚠ AVERTISSEMENT**

Ne pas verser de l'essence dans le réservoir d'huile. Cela risquerait de provoquer un incendie ou une explosion.

F0M-U41E3-11



21

**AFTER OPERATION****APRÈS L'UTILISATION**

After removing from water:

- Flush jet pump and hull with fresh water. Remove stern drain plugs.
- Start engine and rapidly squeeze and release throttle lever for 10-15 seconds to drain any water remaining in exhaust system.
- Refer to the Owner's Manual for maintenance and storage information.

*Après avoir retiré le scooter de l'eau:*

- *Rincer la pompe de propulsion et la coque à l'eau claire. Retirer les bouchons de purge de la poupe.*
- *Mettre le moteur en marche, puis actionner et relâcher rapidement le levier d'accélération de façon répétée pendant 10 à 15 secondes afin de purger toute l'eau du circuit d'échappement.*
- *Entretien et entreposer le scooter des mers conformément aux instructions données dans le manuel d'utilisation.*

(F0P-U41E1-21)

22

**RATED PERSON CAPACITY: 3**  
**MAXIMUM LOAD: 240 kg (530 lb)**  
**CAPACITÉ MAXIMALE: 3 personnes**  
**CHARGE MAXIMALE: 240 kg(530 lb)**

YAMAHA

F0P-U41G1-11

23



**YAMAHA MOTOR CO., LTD.**  
**SHIZUOKA JAPAN**

YAMAHA

4GB-2155A-00

24

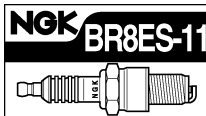

(66V-42791-00)



EJU00999



## Safety information

The safe use and operation of this watercraft is dependent upon the use of proper riding techniques, as well as upon the common sense, good judgment, and expertise of the operator. Before using this watercraft, make sure that its use is permitted under local laws, bylaws and regulations and always operate the watercraft in full conformity with any requirements and limitations imposed. Every operator should know the following requirements before riding the watercraft.

- Before operating the watercraft, read this Owner's/Operator's Manual, the Riding Practice Guide, and all warning and caution labels on the watercraft. These materials should give you an understanding of the watercraft and its operation.
- Never allow anyone to operate this watercraft until they too have read this Owner's/Operator's Manual, the Riding Practice Guide and all warning and caution labels.

EJU01207

## Limitations on who may operate the watercraft

- Yamaha recommends a minimum operator age of 16 years old. Adults must supervise use by minors. Know your local operator age and training requirements.

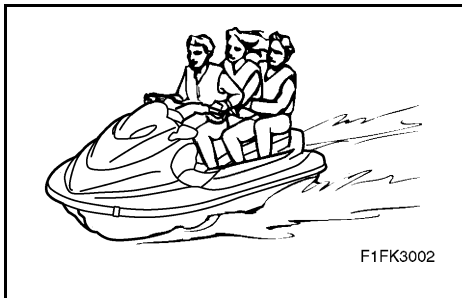

- This watercraft is designed to carry the operator and up to 2 passengers. Never exceed the maximum load limit or allow more than 3 persons (or 2 persons if a water-skier is being pulled) to ride the watercraft at one time.

Maximum load: 240 kg (530 lb)  
Load is the total weight of cargo, operator and passengers.

- Do not operate the watercraft with any passengers on board until you have considerable practice and experience riding alone. Operating the watercraft with passengers requires more skill. Take the time to become accustomed to the handling characteristics of the watercraft before trying any difficult maneuvers.





EJU01001

## Cruising limitations

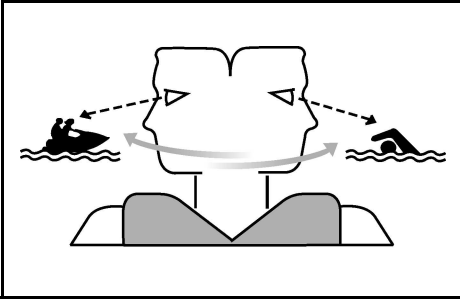

- Scan constantly for people, objects, and other watercraft. Be alert for conditions that limit your visibility or block your vision of others.
- Operate defensively at safe speeds and keep a safe distance away from people, objects, and other watercraft.
- Do not follow directly behind watercraft or other boats.
- Do not go near others to spray or splash them with water.
- Avoid sharp turns or other maneuvers that make it hard for others to avoid you or understand where you are going.
- Avoid areas with submerged objects or shallow water.
- Ride within your limits and avoid aggressive maneuvers to reduce the risk of loss of control, ejection, and collision.
- This is a high performance boat—not a toy. Sharp turns or jumping wakes or waves can increase the risk of back/spinal injury (paralysis), facial injuries, and broken legs, ankles and other bones. Do not jump wakes or waves.

- Do not operate the watercraft in rough water, bad weather or when visibility is poor; this may lead to an accident causing injury or death. Be alert to the possibility of adverse weather. Take note of weather forecasts and the prevailing weather conditions before setting out on your watercraft.
- As with any water sport, you should not ride your watercraft without someone else near by. If you ride further than swimming distance from shore, you should ride by another boat or watercraft, but make sure you stay a safe distance away. It's good common sense!

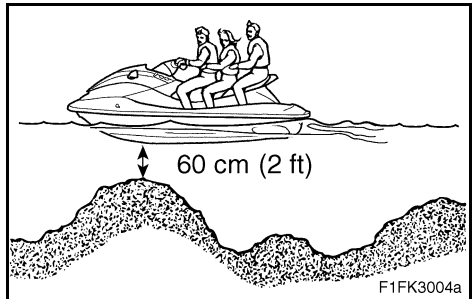

- Never operate in water that is less than 60 cm (2 ft) deep, otherwise you increase your chance of hitting a submerged object, which could result in injury.



- This watercraft is not equipped with lighting required for night operation. Do not operate the watercraft after sunset or before dawn, otherwise you increase the risk of colliding with another boat, which could result in severe injury or death.

EJU01208

## Operation requirements

- All riders must wear a personal flotation device (PFD) that is approved by the appropriate authorities and suitable for personal watercraft use.
- Wear protective clothing. Severe internal injuries can occur if water is forced into body cavities as a result of falling into water or being near the jet thrust nozzle. Normal swimwear does not adequately protect against forceful water entry into rectum or vagina. All riders must wear a wetsuit bottom or clothing that provides equivalent protection. Such clothing includes thick, tightly woven, sturdy and snug-fitting apparel such as denim, but does not include spandex or similar fabrics, like those used in bicycle shorts.

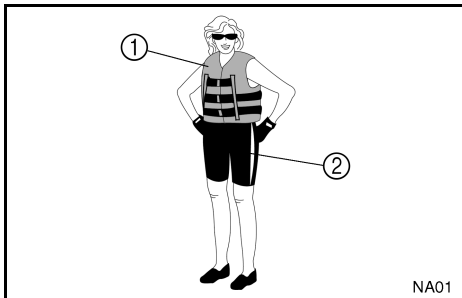

① Authority-approved PFD

② Wetsuit bottom

- Eye protection is recommended to keep wind, water, and glare from the sun out of your eyes while you operate your watercraft. Restraining straps for eyewear are made which are designed to float should your eyewear fall in the water. Footwear and gloves are recommended.



- You must decide whether to wear a helmet while you ride for recreation. You should know that a helmet could help protect you in certain kinds of accidents and that it could injure you in others.

A helmet is designed to provide some head protection. Although helmets cannot protect against all foreseeable impacts, a helmet might reduce your injuries in a collision with a boat or other obstacle.

A helmet may have potential safety hazards, as well. Falling into the water could risk the chance of the helmet catching water, commonly known as “bucketing,” and the resulting strain on your neck could cause choking, severe and permanent neck injuries, or death. A helmet could also increase the risk of an accident if it reduces your vision or hearing, or if it distracts you or increases your fatigue.

How should you decide if a helmet’s potential safety benefits outweigh its potential risks for you? Consider your particular riding conditions. Consider factors such as your riding environment and your riding style and ability. Also consider the likelihood of traffic congestion, and the water surface conditions. If you decide to wear a helmet based upon your riding circumstances, choose one carefully. Look for a helmet designed for personal watercraft use, if possible. If you will be engaging in closed-course competition, follow the helmet requirements of the sanctioning organization.



- NEVER operate the watercraft after consuming alcohol or taking other drugs.
- For reasons of safety and proper care of the watercraft, always perform the pre-operation checks listed on page 3-5 before operating the watercraft.
- The operator and passengers should always keep both feet in the footwell when the watercraft is in motion. Lifting your feet increases your chances of losing your balance, and your feet being hit by objects outside the watercraft. Do not give a ride to children if their feet cannot reach the floor of the footwell.

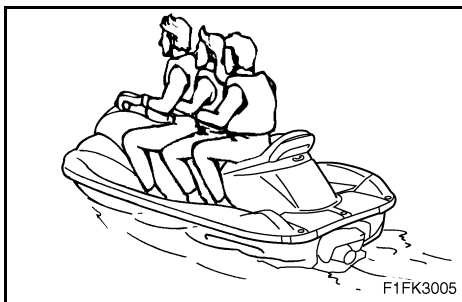

- Passengers should firmly hold on to the person in front of them.
- Always consult your doctor on whether it is safe for you to ride this watercraft if you are pregnant or in poor health.



- Do not attempt to modify this watercraft! Modifications to your watercraft may reduce safety and reliability, and render the watercraft unsafe or illegal for use.

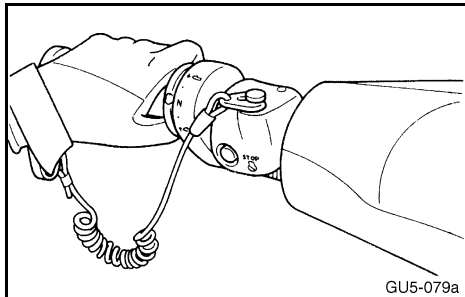

- Attach the engine shut-off cord (lanyard) to wrist and keep it free from the handlebars so that the engine stops if the operator falls off. After riding, remove the engine shut-off cord from the watercraft to avoid accidental starting or unauthorized use by children or others.
- Scan carefully for swimmers and stay away from swimming areas. Swimmers are hard to see and you could accidentally hit someone in the water.
- Avoid being hit by another boat! You should always take the responsibility to watch for traffic; other boaters may not be watching for you. If they do not see you, or you maneuver more quickly than other boaters expect, you risk a collision.
- Maintain a safe distance from other boats or watercraft, and also watch for boats' ski ropes or fishing lines. Obey the "Safe boating rules," and be sure to check behind you before making a turn. (See Safe boating rules on page 1-17.)

EJU01382

## Recommended equipment

The following items should be carried on board your watercraft:

- Sound-signaling device  
You should carry a whistle or other sound-signaling device that can be used to signal other boats.
- Visual distress signals  
It is recommended that an authority-approved pyrotechnic device be stored in a waterproof container on your watercraft. A mirror can also be used as an emergency signal. Contact your Yamaha dealer for more information.
- Watch  
A watch is helpful so you will know how long you have been operating.
- Towline  
A towline can be used to tow a disabled watercraft in an emergency.



EJU01003

## Hazard information

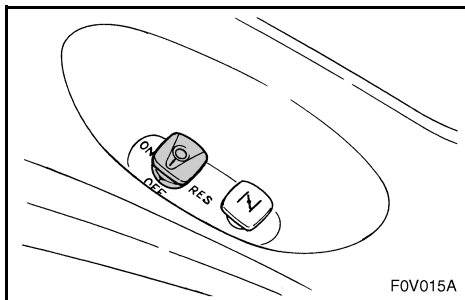

- When transporting or storing your watercraft, always place the fuel cock knob in the “OFF” position, otherwise gasoline may overflow from the carburetor.
- Never start the engine or let it run for any length of time in an enclosed area. Exhaust fumes contain carbon monoxide, a colorless, odorless gas that may cause loss of consciousness and death within a short time. Always operate the watercraft in an open area.

EJU01209

## Watercraft characteristics

- Jet thrust turns the watercraft. Releasing the throttle completely produces only minimum thrust. If you are traveling at speeds above trolling, you will have rapidly decreasing ability to steer without throttle. You may still have some turning ability immediately after releasing the throttle, but once the engine slows down, the watercraft will no longer respond to handlebar input until you open the throttle again or you reach a trolling speed. Practice turning in an open area without obstructions until you have a good feel for this maneuver.
- This watercraft are water-jet propelled. The jet pump is directly connected to the engine. This means that jet thrust will produce some movement whenever the engine is running. There is no “neutral” position. You are in either “forward” or “reverse,” depending upon the shift lever position.
- Do not use the reverse function to slow down or stop the watercraft as it could cause you to lose control, be ejected, or impact the handlebars. This could increase the risk of back/spinal injury (paralysis), facial injuries, and broken legs, ankles, and other bones. You could also damage the shift mechanism.



- Reverse can be used to slow down or stop during slow speed maneuvering, such as when docking. Once the engine is idling, shift to reverse and gradually increase engine speed. Make sure that there are no obstacles or people behind you before shifting into reverse.
- Keep away from intake grate ① while the engine is on. Items such as long hair, loose clothing, or PFD straps can become entangled in moving parts resulting in severe injury or drowning.
- Never insert any object into the jet thrust nozzle ② while the engine is running. Severe injury or death could result from coming in contact with the rotating parts of the jet pump.

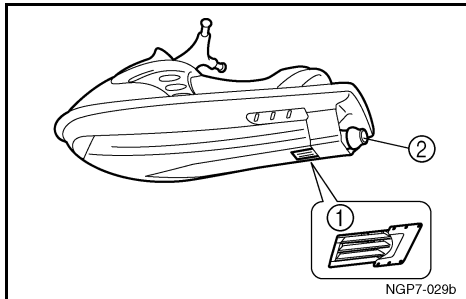

- Stop the engine and remove the clip ③ from the engine shut-off switch ④ before removing any debris or weeds, which may have collected around the jet intake.

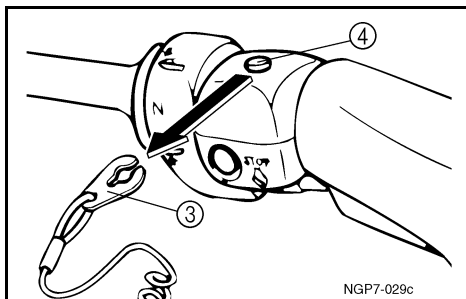

EJU01210

## Water-skiing

You can use the watercraft for water-skiing if it has the seating capacity to carry the operator, a rearward-facing spotter, and the water-skier when he or she is not skiing.

The watercraft must also have a cleat ⑤ designed to pull a ski tow rope; do not attach the tow rope to any other location.

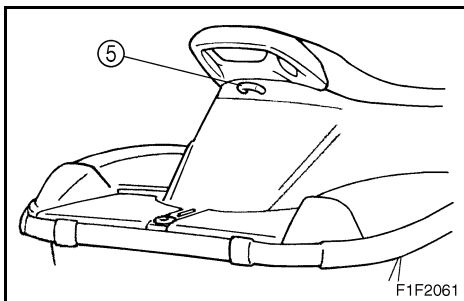

It is the watercraft operator's responsibility to be alert to the safety of the water-skier and others. Know and follow all local water-skiing regulations in effect for the waters in which you will be operating.

The operator should be comfortable carrying passengers before attempting to pull a skier.

The following are some important considerations for minimizing risks while water-skiing.

- The skier should wear an approved PFD, preferably a brightly colored one so boat operators can see the skier.
- The skier should wear protective clothing. Severe internal injuries can occur if water is forced into body cavities as a result of falling into the water. Normal swimwear does not adequately protect against forceful water entry into rectum or vagina. The skier should wear a wetsuit bottom or clothing that provides equivalent protection.



- A second person should be on board as a spotter to watch the skier; in many places it is required by law. Let the skier direct the operator's control of speed and direction with hand signals.

The spotter should sit securely on the passenger seat and hold onto the handgrip with feet firmly on the footrest for proper balance while facing to the rear to watch the skier's hand signals and his or her condition.

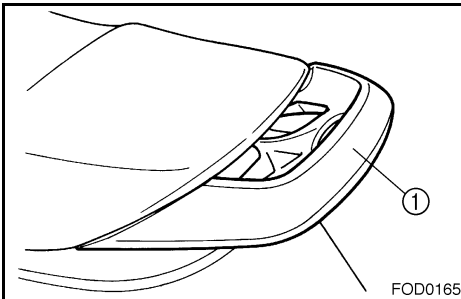
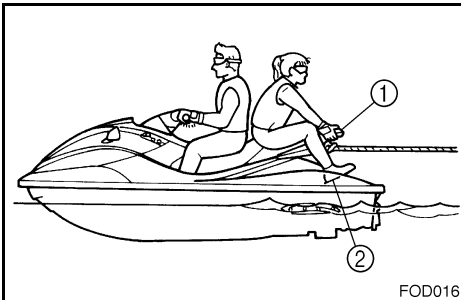

- ① Handgrip
- ② Footrest

- Your control while pulling a skier is affected by the skier's ability, as well as water and weather conditions.

- When preparing to pull a skier, operate the watercraft at the slowest possible speed until the watercraft is well away from the skier and slack in the towrope is taken up. Make sure that the rope is not looped around anything.

After checking that the skier is ready and that there is no traffic or other obstacles, apply enough throttle to raise the skier.

- Make smooth, wide turns. The watercraft is capable of very sharp turns, which could exceed the abilities of the skier. Keep the skier at least 50 m (150 ft), about twice the distance of a standard towrope, from any potential hazard.
- Be alert to the hazard of the towrope handle snapping back at the watercraft when the skier falls or is unable to get up on the skis.
- Towing heavy or bulky objects other than skiers, such as another boat or watercraft, can cause loss of steering control and create a hazardous condition. If you must tow another boat in an emergency situation, operate slowly and cautiously.



EJU01005

## Safe boating rules

Your Yamaha watercraft is legally considered a powerboat. Operation of the watercraft must be in accordance with the rules and regulations governing the waterway on which it is used.

EJU01006

## Enjoy your watercraft responsibly

You share the areas you enjoy when riding your watercraft with others and with nature. So your enjoyment includes a responsibility to treat these other people, and the lands, waters, and wildlife with respect and courtesy.

Whenever and wherever you ride, think of yourself as the guest of those around you. Remember, for example, that the sound of your watercraft may be music to you, but it could be just noise to others. And the exciting splash of your wake can make waves others won't enjoy. Avoid riding close to shoreline homes and waterfowl nesting areas or other wildlife areas, and keep a respectful distance from fishermen, other boats, swimmers, and populated beaches. When travel in areas like these is unavoidable, ride slowly and obey all laws.

Remember that pollution can be harmful to the environment. Do not refuel or add oil where a spill could cause damage to nature. Remove your watercraft from the water and move it away from the shoreline before refueling. And keep your surroundings pleasant for the people and wildlife that share the waterways: don't litter!

When you ride responsibly, with respect and courtesy for others, you help ensure that our waterways stay open for the enjoyment of a variety of recreational opportunities.



# FEATURES AND FUNCTIONS



**Location of main components** .....2-1

## Operation of controls and other

<b>functions</b> .....	2-5
Rear seat .....	2-5
Front seat .....	2-6
Hood .....	2-7
Fuel tank filler cap .....	2-8
Oil tank filler cap .....	2-8
Fuel cock knob .....	2-9
Engine stop switch .....	2-10
Engine shut-off switch .....	2-10
Choke knob .....	2-10
Throttle lever .....	2-11
Start switch .....	2-11
Cooling water pilot outlet .....	2-12
Steering system .....	2-12
Tilt lever .....	2-13
Shift lever .....	2-14
Quick Shift Trim System (QSTS)	
selector .....	2-15
Handgrip .....	2-16
Engine overheat warning system .....	2-17
Multifunction meter .....	2-19
PADLOC (Programmable digital	
locking ignition) .....	2-20
Tachometer .....	2-22
Speedometer .....	2-23
Fuel meter .....	2-23
Engine oil meter .....	2-24
Clock .....	2-24
Hour meter .....	2-25
Trip timer .....	2-25
Tripmeter .....	2-26
Fuel warning indicator .....	2-26
Oil warning indicator .....	2-27
Engine overheat warning	
indicator .....	2-27
Battery warning indicator .....	2-28
Storage compartments .....	2-29



EJU01008

## Location of main components

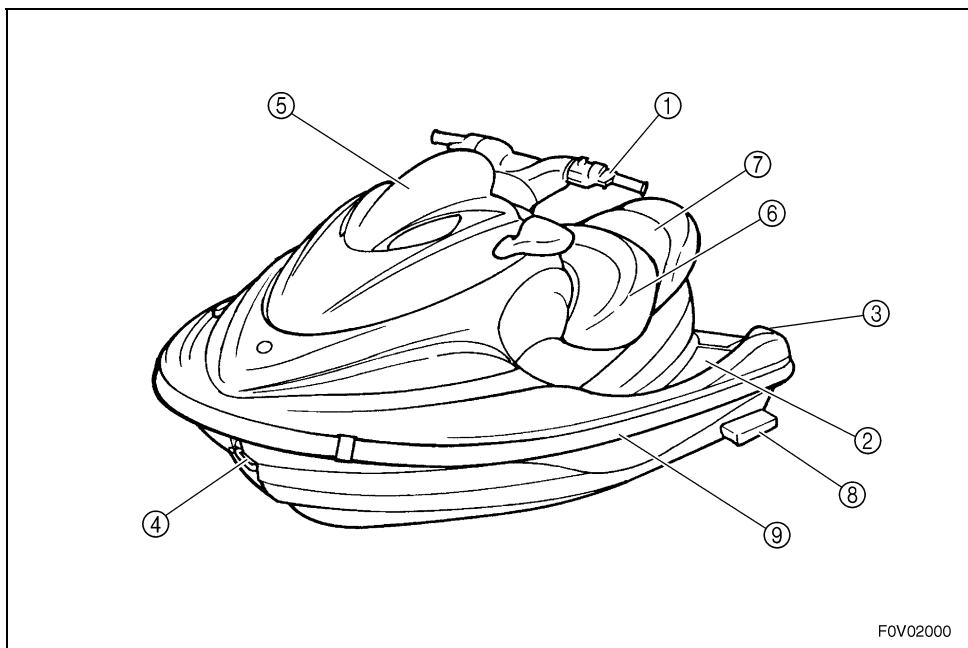

- ① **Handlebars**  
Use to control direction.
- ② **Footwell**  
Use to place feet for balance.
- ③ **Footrest**  
To keep proper balance while facing to the rear to watch the skier.
- ④ **Bow eye**  
Use to attach rope for transporting, mooring or towing the watercraft in an emergency.
- ⑤ **Hood**
- ⑥ **Front seat**
- ⑦ **Rear seat**
- ⑧ **Sponsons**
- ⑨ **Gunwale**

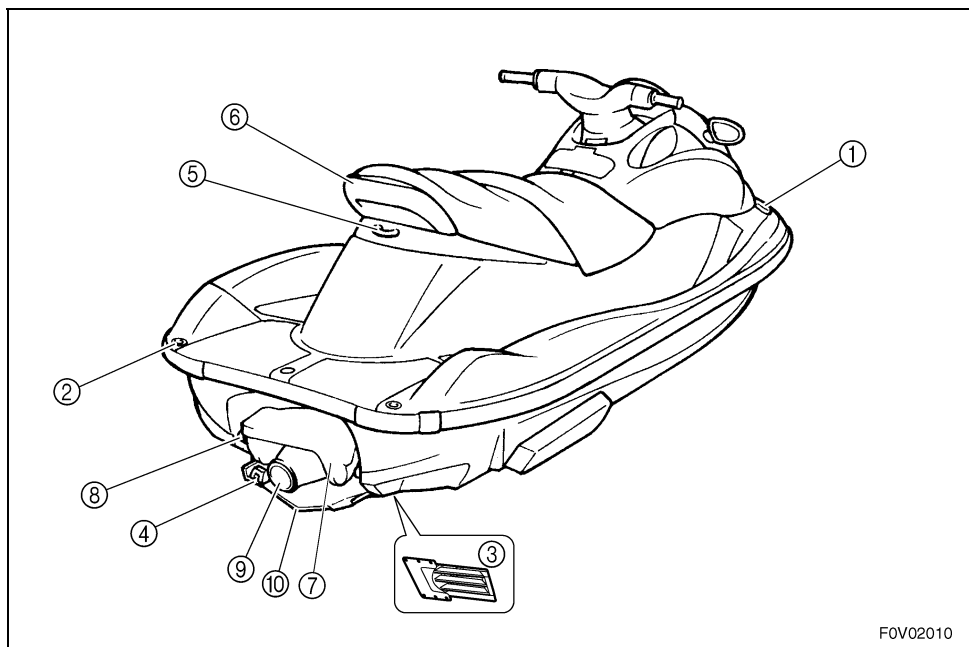

FOV02010

- ① **Fuel tank filler cap**
- ② **Rope holes**
- ③ **Intake grate**  
Prevents debris from getting into the jet pump.
- ④ **Speed sensor**
- ⑤ **Cleat**  
Use to attach a towrope for pulling water-skier, or a rope for mooring the watercraft.
- ⑥ **Handgrip**  
Use for support when boarding the watercraft or when seated facing rearward and acting as a spotter for a water-skier.
- ⑦ **Reverse gate**  
Controls direction of jet thrust when in reverse.
- ⑧ **Stern drain plugs**  
Use to drain water in the bilge when the watercraft is on dry land.
- ⑨ **Jet thrust nozzle**  
Changes the direction of jet thrust according to handlebar position.
- ⑩ **Ride plate**

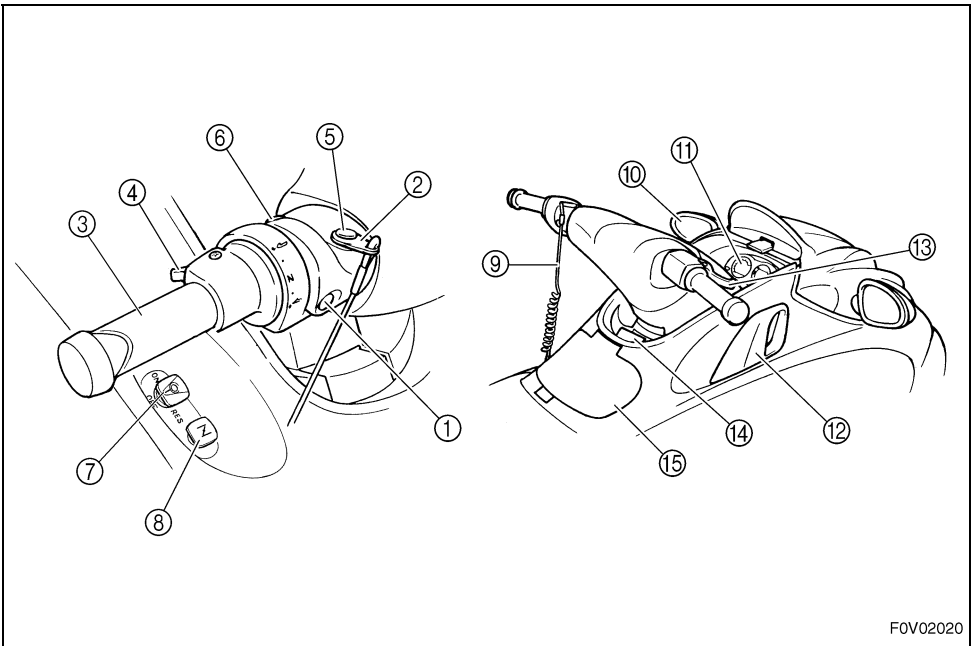

FOV02020

- ① **Engine stop switch**  
Push to stop the engine normally.
- ② **Clip**  
Insert into the engine shut-off switch to enable starting of the engine.  
Remove to stop the engine or prevent accidental starting of the engine or unauthorized use of the watercraft.
- ③ **Quick Shift Trim System (QSTS) selector**  
Use to select the trim angle of the watercraft.
- ④ **QSTS shift lock lever**
- ⑤ **Engine shut-off switch**  
Remove the clip to stop the engine and disable it from starting.
- ⑥ **Start switch**  
Push to start the engine.
- ⑦ **Fuel cock knob**  
Use to select either normal or reserve fuel flow from the fuel tank to the carburetors, or to shut off fuel flow.
- ⑧ **Choke knob**  
Use to start a cold engine.
- ⑨ **Engine shut-off cord (lanyard)**  
Attach to wrist so that the engine stops if the operator falls off the watercraft.
- ⑩ **Adjustable rearview mirrors**
- ⑪ **Multifunction meter**  
Use to check watercraft operation.
- ⑫ **Shift lever**  
Use to put the watercraft into forward or reverse.
- ⑬ **Throttle lever**  
Use to accelerate and decelerate.
- ⑭ **Tilt lever**  
Use to adjust the tilt of the handlebars.
- ⑮ **Glove compartment**

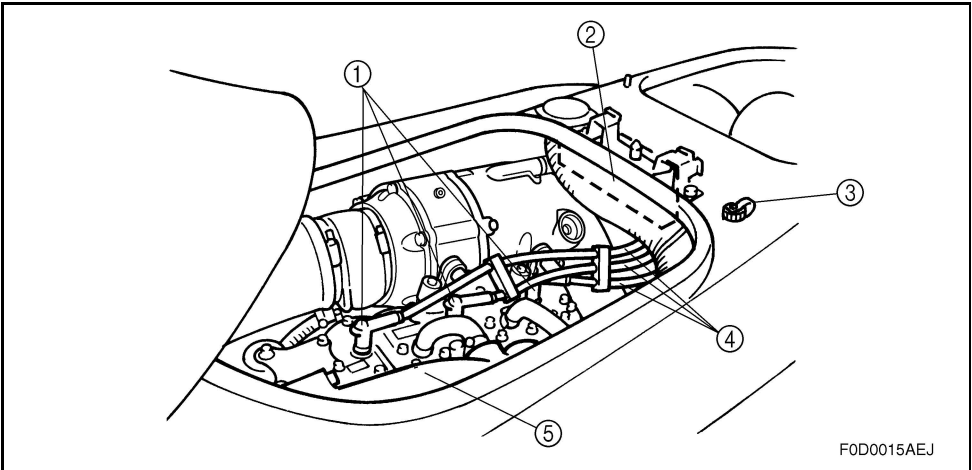

FOD0015AEJ

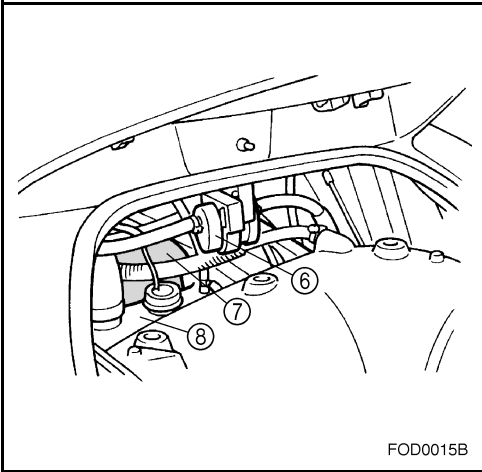

FOD0015B

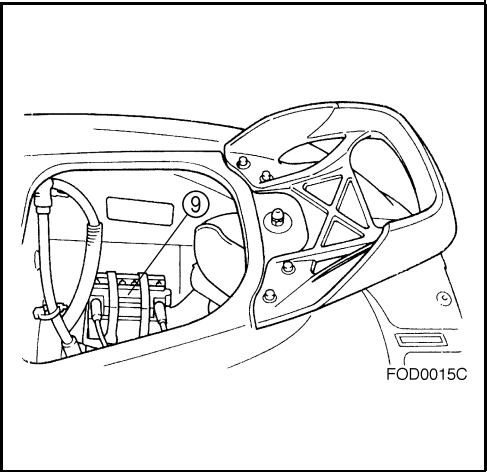

FOD0015C

- ① Spark plugs/Spark plug caps
- ② Electrical box  
Protects electrical components from water.
- ③ Flush hose connector  
Use to flush the engine cooling water passages.
- ④ Spark plug lead
- ⑤ Muffler
- ⑥ Fuel filter
- ⑦ Fuel tank
- ⑧ Oil tank
- ⑨ Battery

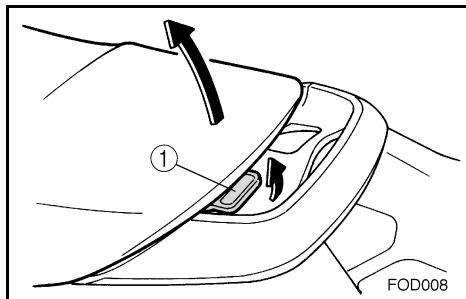

EJU01009

## Operation of controls and other functions

EJU01211

### Rear seat

#### To remove the rear seat:

Pull the rear seat latch ① up, and then pull the seat off.

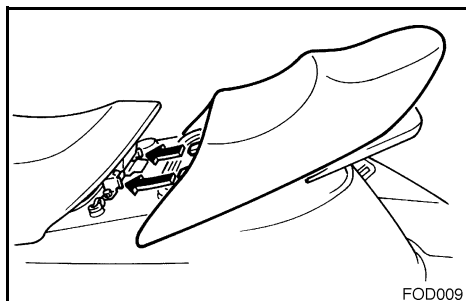

#### To install the rear seat:

Insert the projections on the front of the seat into the stays on the deck, and then push the rear of the seat down to lock it in place securely.

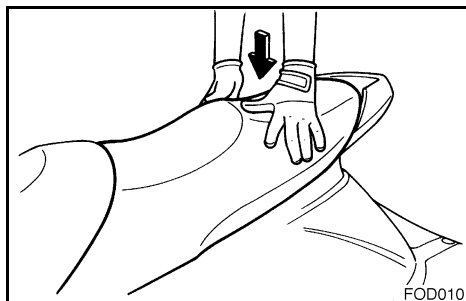



EJU01212

## Front seat

### To remove the front seat:

1. Remove the rear seat.
2. Pull the front seat latch ② up, and then pull the seat off.

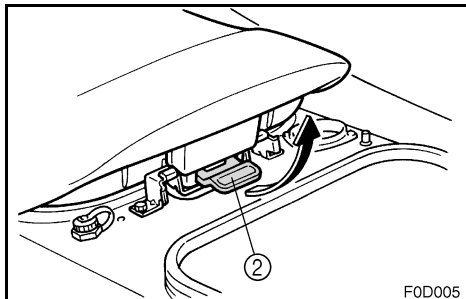

### To install the front seat:

1. Insert the projections on the front of the seat into the stays on the deck, and then push the rear of the seat down to lock it in place.
2. Install the rear seat.

**NOTE:** \_\_\_\_\_  
Make sure that the seats are properly secured before operating the watercraft.

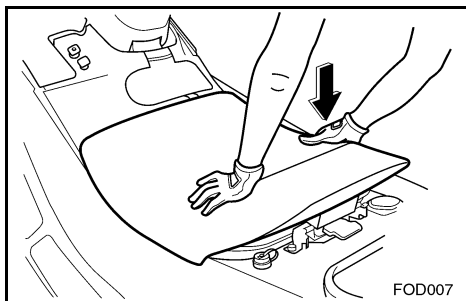
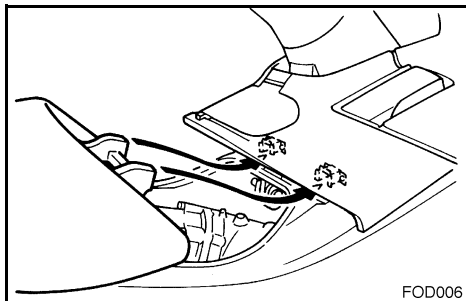



EJU01213

## Hood

To open the hood, pull the latch ① up, and then lift the hood up.

To close the hood, push the hood down to lock it in place.

**NOTE:** \_\_\_\_\_  
Make sure that the hood is properly secured before operating the watercraft.

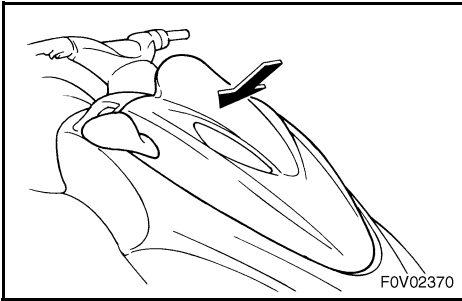
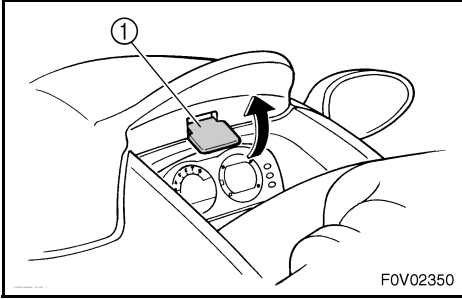



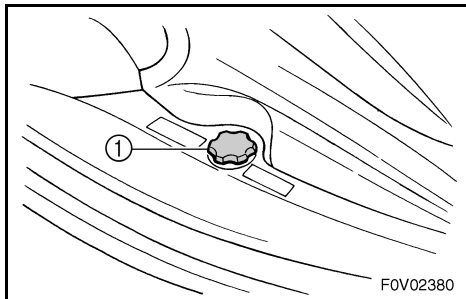

EJU01012

### Fuel tank filler cap

To remove the fuel tank filler cap ①, turn it counterclockwise.

**NOTE:** \_\_\_\_\_

Make sure that the fuel tank filler cap is properly secured before operating the watercraft.

---

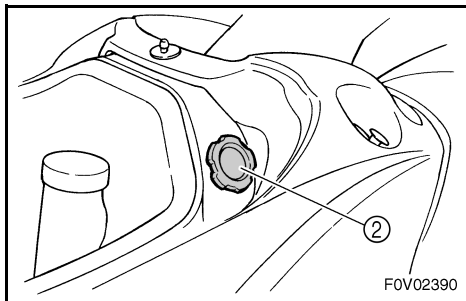

EJU01214

### Oil tank filler cap

**To remove the oil tank filler cap:**

1. Open the hood. (See page 2-7 for hood.)
2. Turn the filler cap ② counterclockwise.

**To install the oil tank filler cap:**

Install the filler cap, and then close the hood.

**NOTE:** \_\_\_\_\_

Make sure that the oil tank filler cap and hood are properly secured before operating the watercraft.

---



EJU01014

### Fuel cock knob

The fuel cock supplies fuel from the fuel tank to the carburetors.

The fuel cock knob ① positions are explained as follows and are shown in the illustration.

**OFF:**

With the fuel cock knob in this position, fuel does not flow. Always turn the fuel cock knob to this position when the engine is not running.

**ON:**

With the fuel cock knob in this position, fuel flows to the carburetors. Turn the fuel cock knob to this position when starting the engine and operating the watercraft.

**RES:**

This indicates reserve. With the fuel cock knob in this position, the fuel reserve is made available. Turn the fuel cock knob to this position if you run out of fuel while operating the watercraft. When this occurs, refuel as soon as possible and be sure to turn the fuel cock knob back to “ON”!

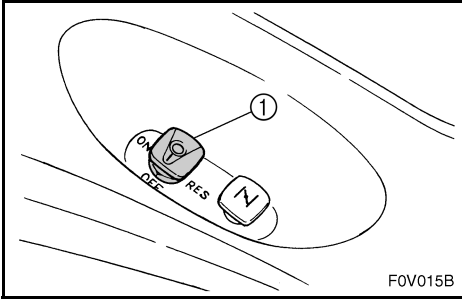

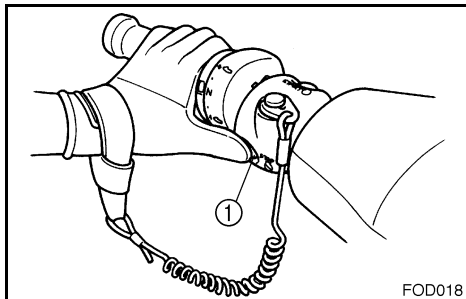

EJU01015

### Engine stop switch

Push this switch ① (red button) to stop the engine normally.

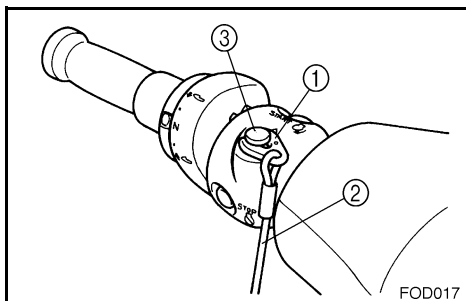

EJU01016

### Engine shut-off switch

Insert the clip ①, on the end of the engine shut-off cord ②, under the engine shut-off switch ③ (black button). The engine will stop automatically when the clip is removed from the switch, such as if the operator falls off the watercraft.

#### **⚠WARNING**

- Always attach the engine shut-off cord to your wrist and the clip to the engine shut-off switch BEFORE starting the engine.
- To prevent accidental starting of the engine or unauthorized use by children or others, always remove the clip from the shut-off switch when the engine is not running.

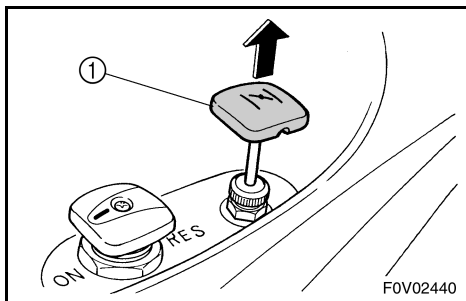
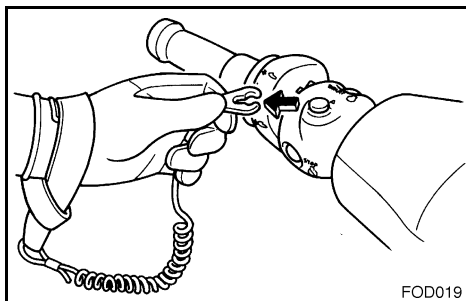

EJU01215

### Choke knob

Starting a cold engine requires a richer air-fuel mixture, which is supplied by the choke.

Pull the knob ① out to turn the choke on.  
Push the knob in to turn the choke off.

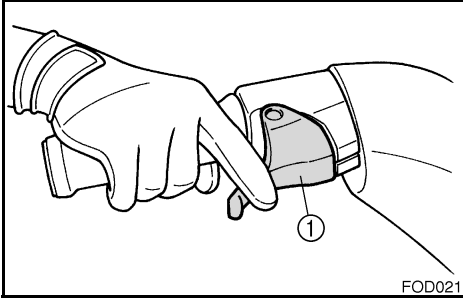

EJU01018

### Throttle lever

Squeeze the throttle lever ① to increase engine speed.

Release the throttle lever to decrease engine speed or to return it to the idle position.

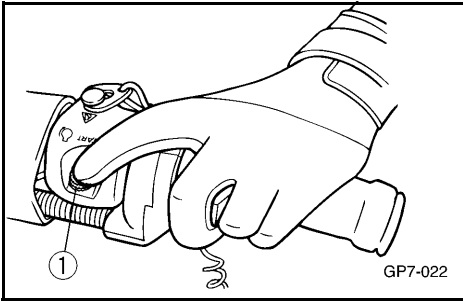

EJU01216

### Start switch

Push the start switch ① (green button) to start the engine.

**NOTE:**

- The engine will not start when the clip is removed from the engine shut-off switch.
- The engine will not start if the “LOCK” mode of the multifunction meter has been selected. (See page 2-21 for “PADLOC” mode selection procedures.)



EJU01020

## Cooling water pilot outlet

This watercraft is equipped with a cooling water pilot outlets.

When the engine is running, cooling water is circulated in the engine, and then it is discharged from the pilot outlets.

To check for proper operation of the cooling system, check that water is being discharged from the pilot outlets. If water is not being discharged from the outlets, cooling water may not be circulating in the engine. When this occurs, stop the engine and check for the cause. (See pages 2-17 and 5-4 for further instructions.)

### NOTE:

If the cooling water passages are dry, it will take about 20 seconds for the water to reach the outlet after the engine is started.

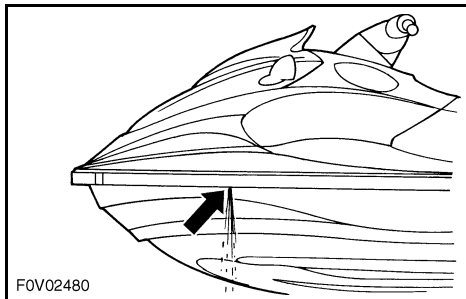

F0V02480

EJU01021

## Steering system

Your watercraft can be steered by turning the handlebars ① the same direction you wish to travel.

When the handlebars are turned, the angle of the jet thrust nozzle ② is changed, and the direction of the watercraft is changed accordingly. Since the strength of the jet thrust determines the speed and direction of a turn, the throttle must always be open when attempting a turn, except at trolling speed.

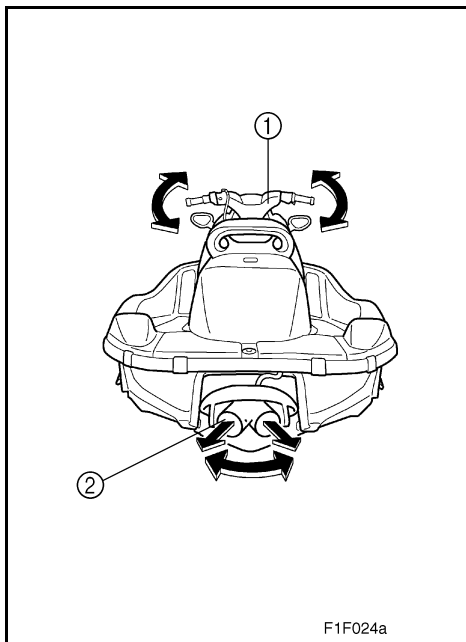

F1F024a

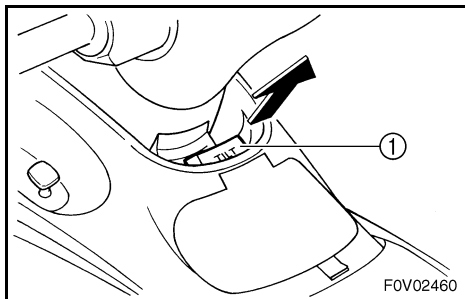

EJU01217

## Tilt lever

The tilt lever ① is located in front of the glove compartment and is used to adjust the tilt of the handlebars.

To adjust the tilt, pull the tilt lever up, and then move the handlebars up or down to the desired position.

### **⚠WARNING**

- **Never touch the tilt lever during operation, otherwise the handlebars may suddenly change position, which may lead to an accident.**
- **Be sure to fasten the tilt lever properly after adjusting the handlebar position. If the handlebars are not properly fastened, they may suddenly change position, which may lead to an accident.**

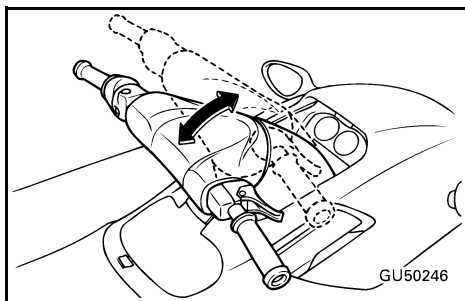



EJU01218

## Shift lever

The shift lever is located on the starboard side of the watercraft and is used to control the reverse gate, which allows the watercraft to move into reverse or forward.

When in the reverse position, the watercraft can be launched from a trailer, or backed up out of tight spots where you cannot turn around easily.

### To shift into reverse:

1. Release the throttle, and then let the engine speed return to idle.
2. Pull the shift lever toward you.

### **⚠WARNING**

- **Make sure that the throttle is completely released and that the engine is at idle before shifting into reverse.**
- **Do not use the reverse function to slow down or stop the watercraft as it could cause you to lose control, be ejected, or impact the handlebars.**
- **Use reverse for slow-speed maneuvering only.**
- **Make sure that there are no obstacles or people behind you before shifting into reverse.**
- **Do not touch the reverse gate while the shift lever is being operated, otherwise you could be pinched.**

### To shift into forward:

1. Release the throttle, and then let the engine speed return to idle.
2. Push the shift lever away from you.

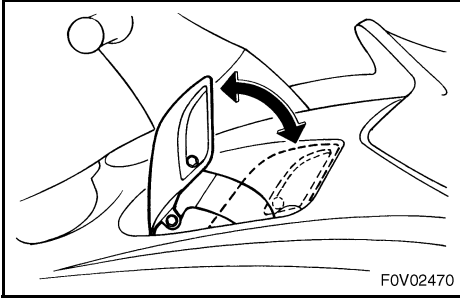



EJU01022

## Quick Shift Trim System (QSTS) selector

The QSTS selector ① is located at the left handlebar grip and is used to adjust the trim angle of the watercraft.

Operating the QSTS selector changes the angle of the jet thrust nozzle vertically. This changes the trim angle of the watercraft.

There are 5 positions: 2 bow down positions ① and ②, neutral "N," and 2 bow up positions ③ and ④.

### To change the trim angle:

1. Reduce engine speed to 3,400 r/min or less.
2. Squeeze the shift lock lever ②, and then turn the QSTS selector to the desired position.
3. Release the shift lock lever to lock the QSTS selector.

### CAUTION:

Do not turn the QSTS selector while operating the watercraft at full throttle, otherwise damage could occur to the QSTS.

The neutral "N" position will provide good performance for most operating conditions.

To enhance particular types of performance, select bow down or bow up.

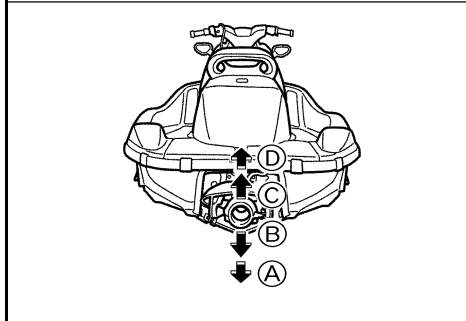
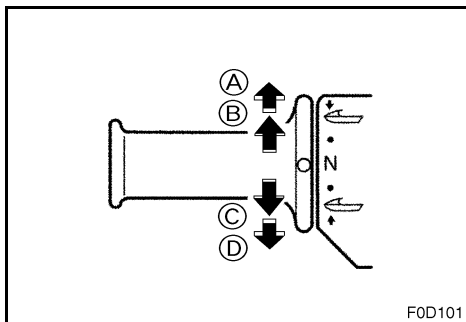
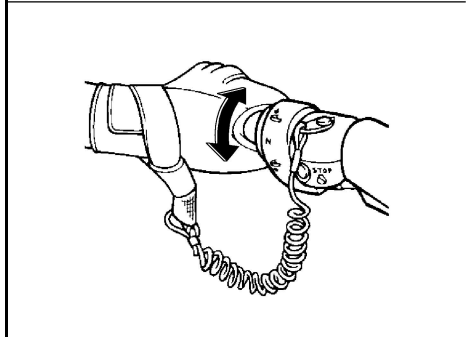
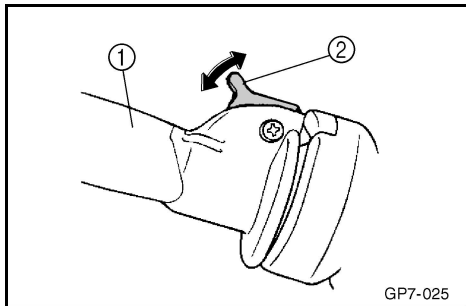





EJU01023

### Bow down

Turn the grip to (A) or (B) and the bow will go down while the watercraft is on plane.

Bow down puts more of the bow in the water. This gives the watercraft more “hook,” which enhances turning performance. This position will also help the watercraft get up on plane more quickly.

At higher speeds, however, the watercraft will have greater tendency to “bow steer” and follow waves and wakes in the water. Fuel economy and maximum speed are also reduced.

EJU01024

### Bow up

Turn the grip to (C) or (D) and the bow will go up while the watercraft is on plane.

Bow up puts less of the bow in the water. There is less water resistance, so straight-ahead acceleration when on plane and top speed are enhanced.

In some conditions, however, the watercraft may tend to “porpoise” (hop in the water). If the watercraft is porpoising, choose neutral or bow down.

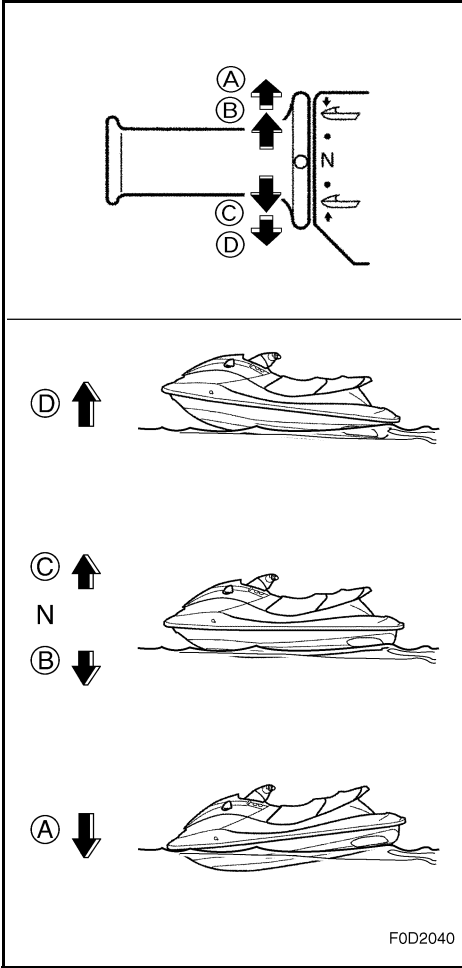

FOD2040

EJU01219

### Handgrip

The handgrip ① provides a handhold for boarding the watercraft and for a spotter when facing rearward.

**CAUTION:** \_\_\_\_\_

**Do not use to tow objects, lift watercraft, or attach tie downs, otherwise damage could occur.**

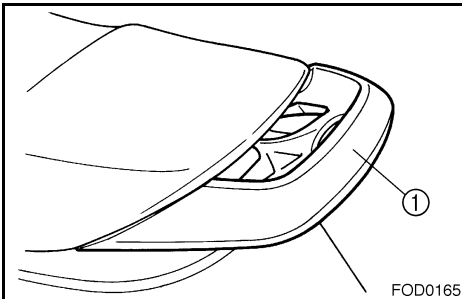

FOD0165



EJU01337

## Engine overheat warning system

The model has an overheat warning device. If the engine starts to overheat, the warning light, indicator and “W.TEMP” on the meter begin to blink and the buzzer sounds intermittently. If this happens, reduce the engine speed and return to beach at low speed. If there is no water discharge at the cooling water pilot outlet while the engine is running, check the jet intake and impeller for clogging.

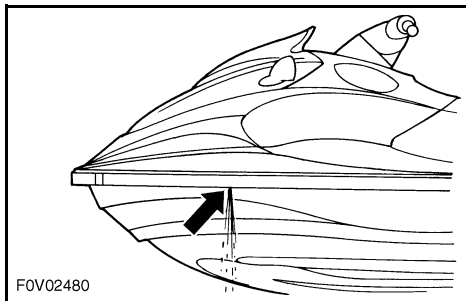
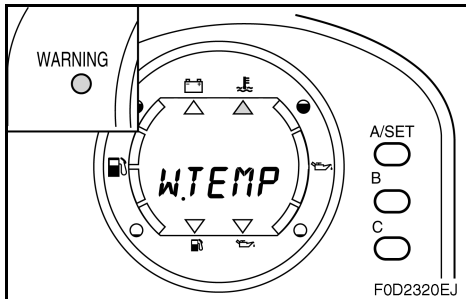

### **⚠ WARNING**

Before attempting to remove weeds or debris from the intake grate or impeller, shut the engine off and remove the clip from the engine shut-off switch. Severe injury or death could result from coming in contact with the rotating parts of the jet pump.

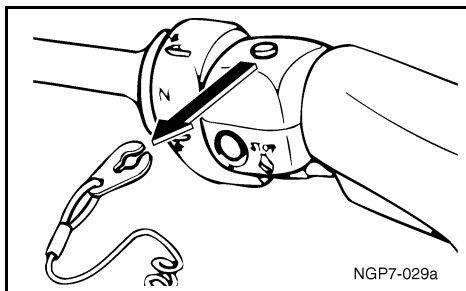

### **CAUTION:**

- Return to shore at low speed if the overheat warning indicator and buzzer are on, and the display shows “W.TEMP.” If you ignore these signals, the engine will stop running and cannot be restarted until the exhaust system cools.
- Have your watercraft inspected and serviced by a Yamaha dealer if the engine stopped due to overheating.

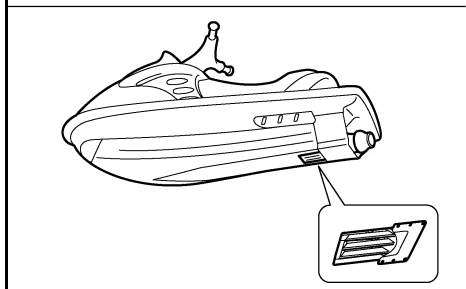



If the initial overheat warning is ignored, engine and exhaust system heat can increase, particularly if the watercraft continues to be operated at higher speed. If so, the warning indicators and buzzer will change from intermittent to constantly on and the overheat system will stop ignition to the engine to reduce the risk of severe overheating. The engine cannot be restarted until it cools down, so it may be necessary to have the watercraft towed back to the beach. Refer to “Towing the watercraft” on page 5-7.

**NOTE:**

- The buzzer stops sounding if any button on the meter is pressed.
- Ask a Yamaha dealer to inspect the watercraft if there is no apparent reason for overheating.



EJU01221

## Multifunction meter

This meter contains following functions for help and convenience in operating the watercraft.

- ① "MODE" button
- ② "SET" button
- ③ "CODE" setting buttons
- ④ Tachometer
- ⑤ Speedometer
- ⑥ Fuel meter
- ⑦ Engine oil meter
- ⑧ Display for Clock, Hour meter, Trip meter and Trip timer
- ⑨ Warning light
- ⑩ Display for PADLOC and direction of warning indicator
- ⑪ Battery warning indicator
- ⑫ Engine overheat warning indicator
- ⑬ Fuel warning indicator
- ⑭ Oil warning indicator

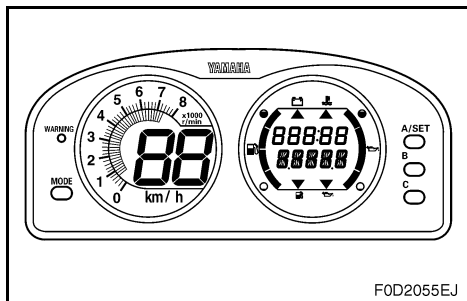
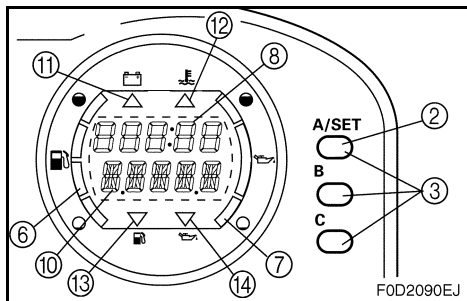
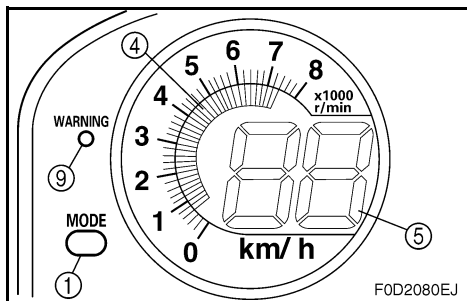
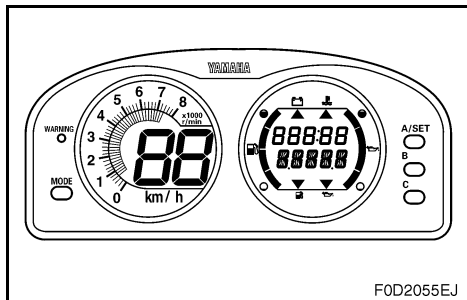

### CAUTION:

- Do not run the engine at full throttle or more than 15 seconds to check the meter for operation on land. The engine could overheat.
- Use the specified resistor-type spark plugs and caps, otherwise the meter may function erratically.

### NOTE:

The demonstration mode display starts showing after the engine starts. Then all displays light up and the buzzer sounds twice.

The meter will operate normally after a few seconds. The current display will continue to operate for 30 seconds after the engine stops.



EJU01222

## PADLOC (Programmable digital locking ignition)

This feature is provided to deter unauthorized use.

The function allows you to choose either “START” or “LOCK” mode, as the situation requires, much as you would use an ignition key in a motor vehicle. If you have previously chosen “LOCK” mode, the engine will not start unless the right code is put in to select “START” mode.

### NOTE:

If you do not use the PADLOC system, it is unnecessary to perform the initial setting of the PADLOC. In this case, the “START” mode is automatically selected.

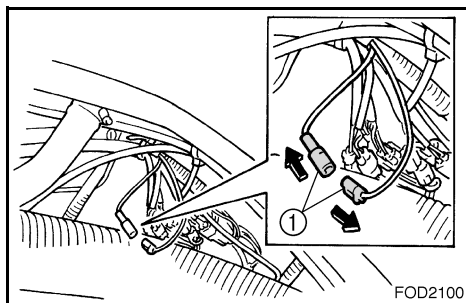

EJU01223

## PADLOC initial setting

1. Disconnect the blue connector ① behind the front storage compartment.
2. After the warning light turns on, press the “MODE” button for at least 3 seconds until the display shows “COdE.” You are ready to set your code.

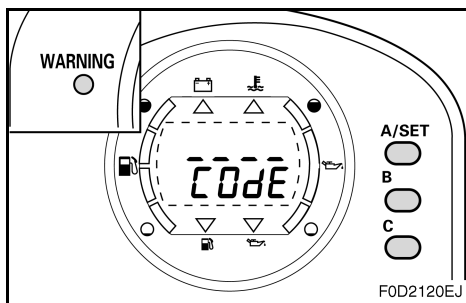
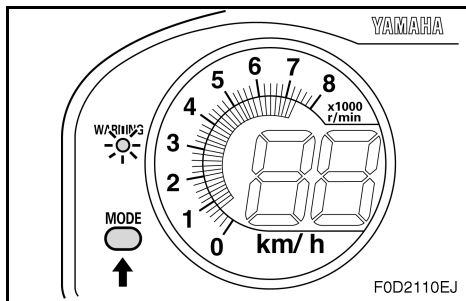

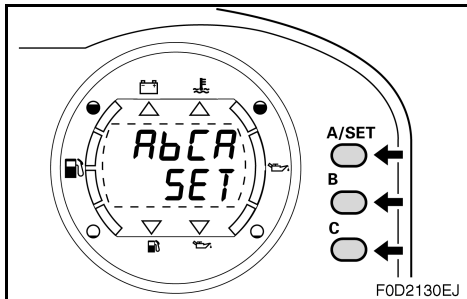

3. Select your four-letter code by pressing the “A/SET,” “B,” or “C” buttons in a desired sequence.

**NOTE:** \_\_\_\_\_  
If you do not press a button for more than 10 seconds, the display automatically turns off. This cancels the process of setting a code.

4. After code setting is complete, the buzzer will sound 3 times and the display will show “SET.” Lastly, the display turns off and the warning light turns on again. After the meter has displayed this sequence, connect the blue connector again.

**NOTE:** \_\_\_\_\_  
● Your own code is kept even if the battery terminal is disconnected.  
● If you forget your own code, or if you want to change the code, do this initial setting procedure again from the beginning.

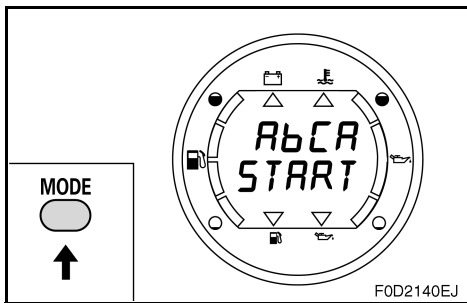

EJU01224

### Selecting “PADLOC” mode

Selecting the desired mode can only be done after the initial setting has been done and while the display is not lit.

1. Press the “MODE” button until the meter displays the current mode, “START” or “LOCK.”

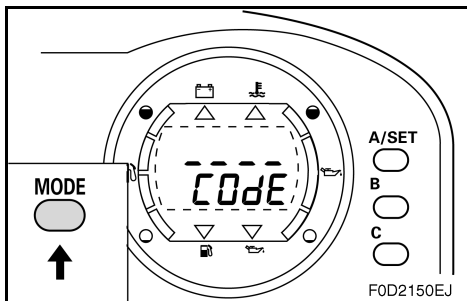

2. With “START” or “LOCK” displayed, press the “MODE” button continuously for about 3 seconds until the display changes to “CODE.”

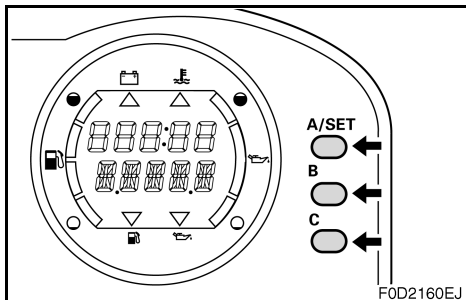

3. Enter your four-letter code by pressing the “A/SET,” “B,” or “C” buttons in the right sequence.

**NOTE:** \_\_\_\_\_  
 If you do not press a button for more than 10 seconds, the display automatically turns off. This cancels the process of selecting the mode.  
 \_\_\_\_\_

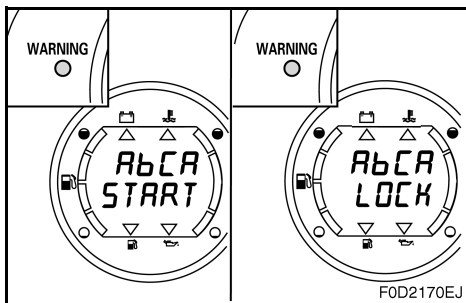

4. If the code entered is correct, the mode will change from the previous mode to either “START” or “LOCK.” Then the mode display and buzzer will operate for 2 seconds.

**NOTE:** \_\_\_\_\_  
 ● Once you select a mode, the mode will not change unless you perform this mode selection sequence again.  
 ● If the wrong code is entered, the mode display shows “ERROR” for 2 seconds and the buzzer will sound 5 times. Then the display returns to “COdE.”  
 \_\_\_\_\_

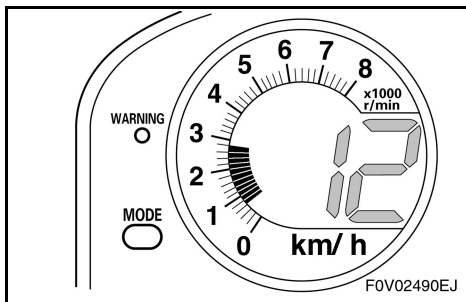
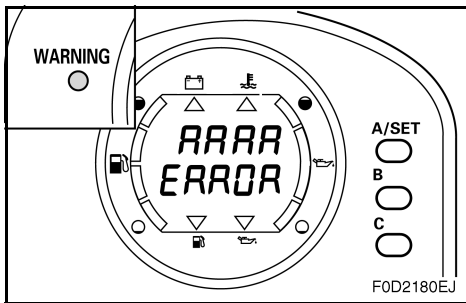

EJU01225

### Tachometer

The engine speed (r/min) is displayed by segments. Each segment indicates a 200 r/min increment.

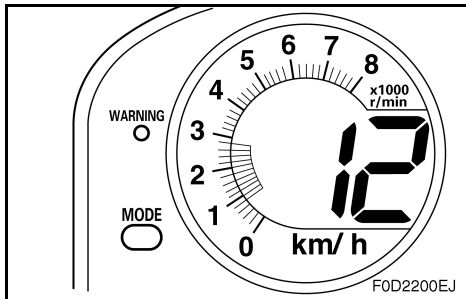

EJU01226

## Speedometer

The meter shows the watercraft speed against water.

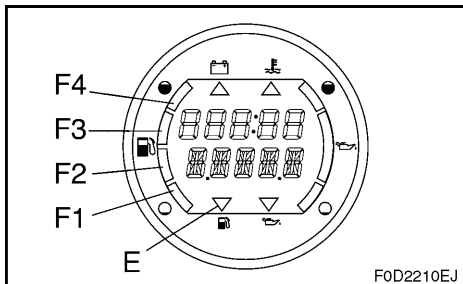

EJU01227

## Fuel meter

The fuel meter is provided for convenient fuel level checking while operating the watercraft.

The fuel meter has 4 segments which show the amount of fuel remaining in the fuel tank.

**NOTE:** \_\_\_\_\_

The indication of the segments differs depending on your operating condition. Use the meter as a reference.

\_\_\_\_\_

	Display		Capacity.L(US gal, Imp gal)
F4 F3 F2 F1		ON	more than 54 (14.3, 11.9)
F3 F2 F1		ON	45~54 (11.9, 9.9)~(14.3, 11.9)
F2 F1		ON	28~45 (7.4, 6.2)~(11.9, 9.9)
F1		ON	17~28 (4.5, 3.7)~(7.4, 6.2)
E		Blinking	0~17 (4.5, 3.7)





EJU01228

## Engine oil meter

The engine oil meter is provided for convenient oil level checking while operating the watercraft.

The engine oil meter has 3 segments which show the amount of oil remaining in the oil tank.

**NOTE:**

The indication of the segments differs depending on your operating condition. Use the meter as a reference.

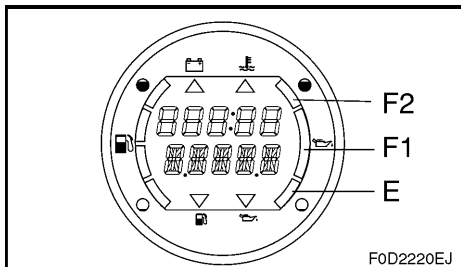

F0D2220EJ

Display			Capacity:L(US gal, Imp gal)
F2 F1		ON	more than 3.7 (0.97,0.81)
F1		ON	1.4~3.7 (0.37,0.31)~(0.97,0.81)
E		Blinking	0~1.4 (0.37,0.31)

EJU01229

## Clock

A 12-hour clock is provided in this meter.

To show the clock, press the "MODE" button until the display shows "CLOCK" while the engine is running.

1. When the display shows "CLOCK," press the mode button for at least 3 seconds.
2. The buzzer will sound once. The hour display and "SET" start blinking. Then press the "A/SET" button until the desired hour is displayed.
3. Press the "MODE" button again.
4. The buzzer will sound once. The minute display and "SET" start blinking. Then press the "A/SET" button until the desired minute is displayed.
5. Press the "MODE" button again.

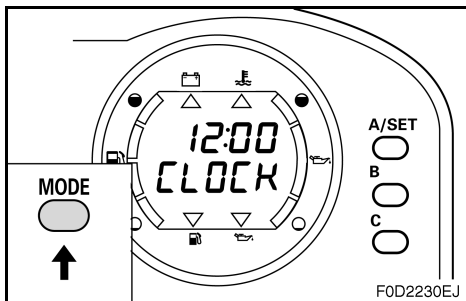

F0D2230EJ

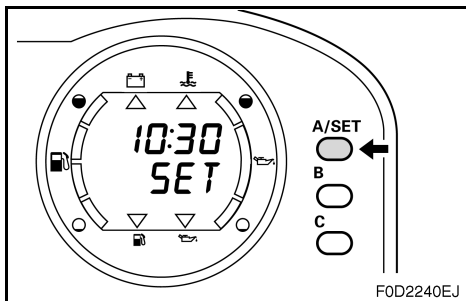

F0D2240EJ



- The buzzer will sound twice. The warning light and “SET” blink for 2 seconds. Then the display turns to “CLOCK” and shows the time.

**NOTE:** \_\_\_\_\_  
 If the battery terminal is disconnected, the clock will be reset to 12:00.

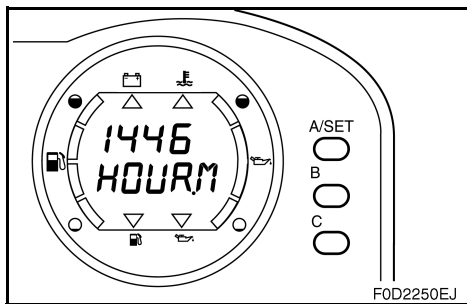

EJU01230

### Hour meter

The hour meter is provided to make it easy to follow the maintenance schedule.

The meter shows how many hours of engine operation have elapsed since the watercraft was new.

To show the hour meter, press the “MODE” button until the display shows “HOUR.M” while the engine is running.

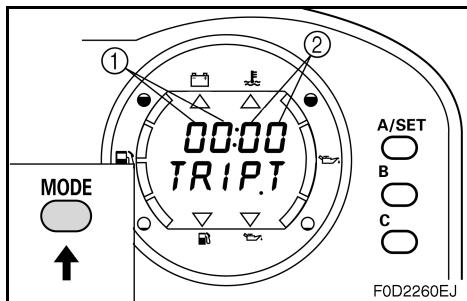

EJU01231

### Trip timer

The trip timer is provided for counting the time traveled on a given trip.

To show the trip timer, press the “MODE” button until the display shows “TRIP.T” while the engine is running.

- ① Minutes
- ② Seconds

- When the display shows “TRIP.T,” press the “A/SET” button to start counting. The buzzer will sound once.
- Press the “A/SET” button again to stop counting. The buzzer will sound once.
- Press “MODE” button for at least 2 seconds to set the time back to 00:00. The buzzer will sound twice. The time display and “TRIP.T” blink for 2 seconds. Now it is ready to start counting.

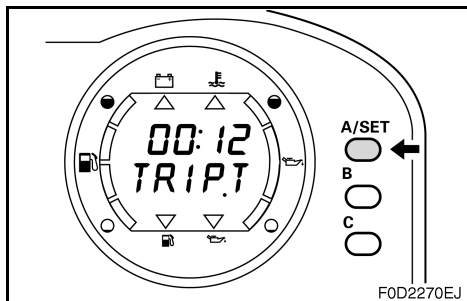



EJU01238

### Tripmeter

A tripmeter is provided for measuring the approximate distance traveled.

To show the tripmeter, press the “MODE” button until the display shows “TRIP” while the engine is running. After showing “TRIP,” the display turns to “.KM.”

1. When the display shows “.KM,” press the “MODE” button for at least 2 seconds.
2. The buzzer will sound twice. The warning light and “.KM” blink for 2 seconds, and “000” is displayed. Now the meter will start to measure the distance you travel.
3. When the tripmeter begins measuring the distance traveled, the “.” to the left of “KM” on the display will blink.

**NOTE:** Measured distance may vary depending on the water surface conditions, and wind direction. The measured distance should be used for a reference.

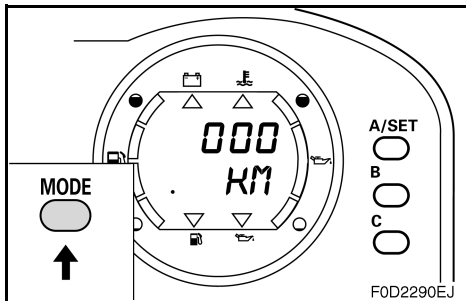
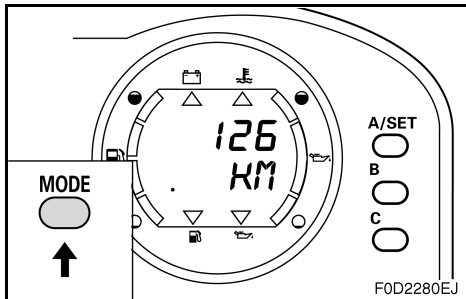

EJU01232

### Fuel warning indicator

If the fuel remaining in the tank drops to about 17 L (4.5 US gal, 3.7 Imp gal), the lowest fuel level segment, the fuel warning indicator, “FUEL” and the warning light begin to blink. The buzzer also starts sounding intermittently.

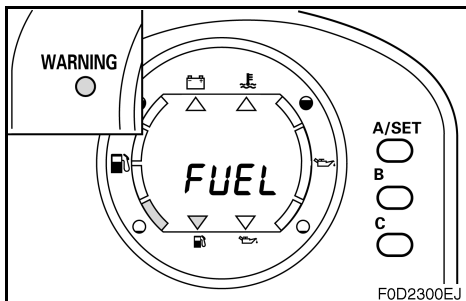

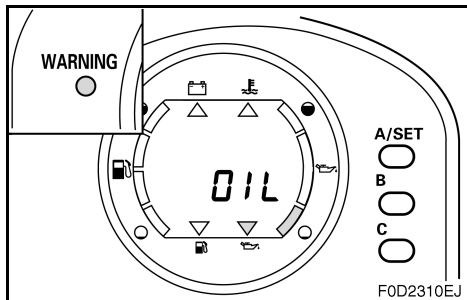

EJU01233

### Oil warning indicator

If the oil remaining in the tank drops to about 1.4 L (0.37 US gal, 0.31 Imp gal) or the oil filter is clogged, the lowest oil level segment, the oil warning indicator, “OIL” and the warning light begin to blink. The buzzer also starts sounding intermittently.

If the oil warning indicator begins to blink, refill with engine oil as soon as possible.

**NOTE:** \_\_\_\_\_  
If the warning indicator blinks with adequate oil in the tank, check the oil filter for clogging.

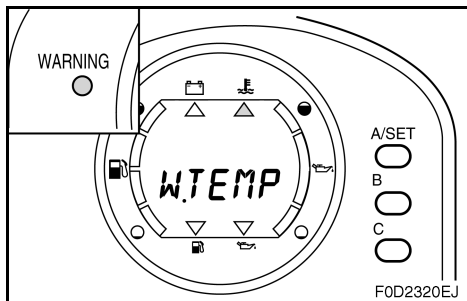

EJU01338

### Engine overheat warning indicator

If the engine starts to overheat, the engine overheat warning indicator, “W.TEMP” and the warning light begin to blink. The buzzer also starts sounding intermittently.

If the engine continues to be operated at higher speed after the warning system indicators have come on intermittently, the warning indicator, “W.TEMP” and the warning light will change to being on continuously. Also, the engine will stop and the buzzer will sound continuously. Refer to “Engine overheat warning system” on page 2-17.

**NOTE:** \_\_\_\_\_  
When the warnings overlap each other, their priority is as follows.

1. Final overheat
2. Initial overheat
3. Oil
4. Fuel
5. Battery



EJU01235

### Battery warning indicator

If the battery voltage becomes less than 11.5 volts, the battery warning indicator, “VOLT” and the warning light begin to blink. The buzzer also starts sounding.

If this happens during operation, beach the watercraft. Then recharge the battery and have the charging system inspected by a Yamaha dealer.

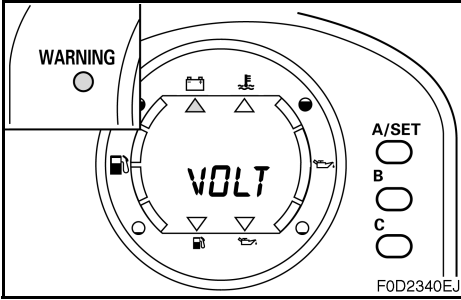

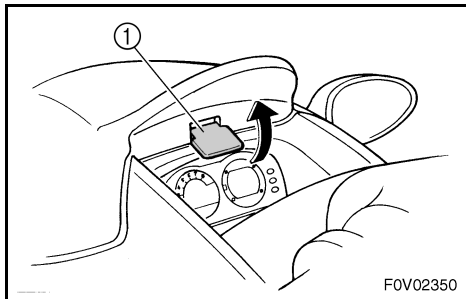

EJU01236

### Storage compartments

A front storage compartment, a glove compartment, and seat storage compartments are provided.

**NOTE:** \_\_\_\_\_

- Make sure that the storage compartments are properly secured before operating the watercraft.
- The storage compartments are not designed to be waterproof. If you carry objects that must be kept dry, such as the manuals, put them in a waterproof bag.

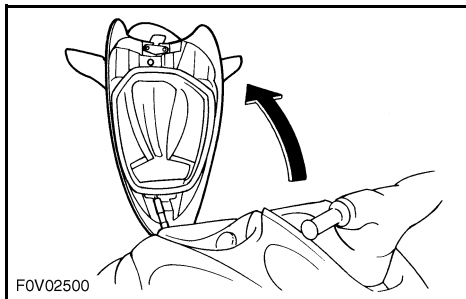

EJU01237

### Front storage compartment

The front storage compartment ② is located at the bow.

To open the front storage compartment, pull the hood latch ① up, and then open the hood.

To close the front storage compartment, push down on the rear of the hood until it latches securely.

**NOTE:** \_\_\_\_\_

The front storage compartment can be removed to access the engine compartment.

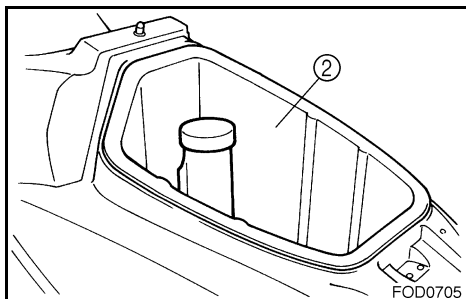

Front storage compartment: Capacity: 56 L (15 US gal, 12 Imp gal) Load limit: 5 kg (11 lb)
--

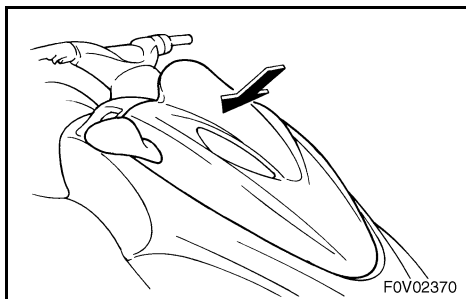



EJU01038

### Glove compartment

A glove compartment ④ is located in front of the seat.

To open the glove compartment, slide the latch ③ toward you, and then lift up the lid.

To close the glove compartment, push the lid down until it locks securely.

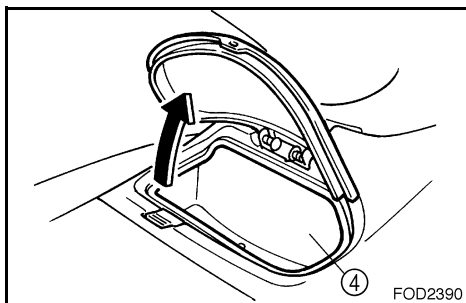
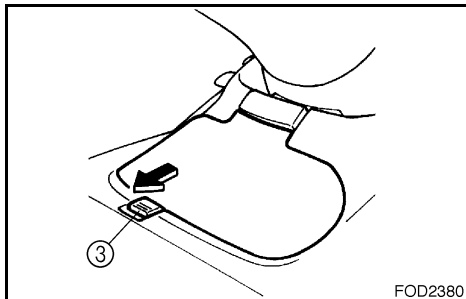

Glove compartment:  
Capacity: 1.7 L (0.45 US gal, 0.37 Imp gal)  
Load limit: 1 kg (2.2 lb)

EJU01239

### Seat storage compartment

The seat storage compartment ⑤ is located under the rear seat.

To open the seat storage compartment, remove the rear seat. (See page 2-5 for rear seat.)

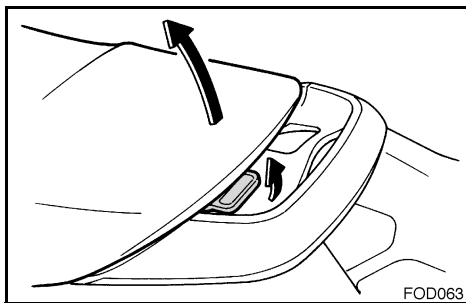

Seat storage compartment:  
Capacity: 30 L (8 US gal, 6.6 Imp gal)  
Load limit: 9 kg (19.8 lb)

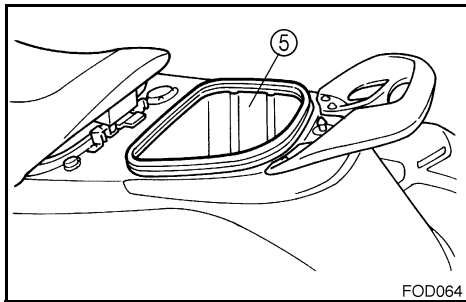



---

**-MEMO-**



# OPERATION

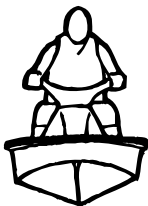

<b>Fuel and oil</b> .....	3-1
Gasoline .....	3-1
2-stroke engine oil .....	3-2
Filling the fuel tank .....	3-3
Filling the oil tank .....	3-4
<b>Pre-operation checks</b> .....	3-5
Pre-operation check list .....	3-5
Pre-operation check points .....	3-6
<b>Operation</b> .....	3-14
Engine break-in .....	3-14
Launching the watercraft .....	3-16
Starting the engine .....	3-16
Stopping the engine .....	3-19
Leaving the watercraft .....	3-19
<b>Operating your watercraft</b> .....	3-20
Getting to know your watercraft .....	3-20
Learning to operate your watercraft .....	3-20
Riding watercraft with passengers .....	3-21
Starting the watercraft .....	3-22
Boarding and starting in deep water .....	3-24
Capsized watercraft .....	3-26
Turning the watercraft .....	3-28
Stopping the watercraft .....	3-30
Beaching the watercraft .....	3-31
Docking the watercraft .....	3-31
Reverse on waterways .....	3-32
Rough water operation .....	3-32
<b>Post-operation checks</b> .....	3-33
<b>Transporting</b> .....	3-35



EJU01041

## Fuel and oil

This engine uses Yamaha's oil injection system, which provides superior lubrication by ensuring the proper oil ratio for all operating conditions. No fuel premixing is necessary except during the engine break-in period. Simply pour gasoline into the fuel tank and oil into the oil tank.

EJU01042

### Gasoline

#### **⚠WARNING**

**GASOLINE AND ITS VAPORS ARE HIGHLY FLAMMABLE AND EXPLOSIVE!**

- Do not smoke when refueling, and keep away from sparks, flames, or other sources of ignition.
- Stop engine before refueling.
- Refuel in a well-ventilated area. Do not stand or sit on the watercraft while refueling in case of fire.
- Take care not to spill gasoline. If gasoline spills, wipe it up immediately with dry rags. Always properly dispose of gasoline-soaked rags.
- Avoid overfilling the fuel tank. Stop filling when the fuel level just reaches the bottom of the filler tube. Do not fill up the filler tube because fuel expands as it warms up and could overflow.
- Tighten the filler cap securely after refueling.
- If you should swallow some gasoline, inhale a lot of gasoline vapor, or get gasoline in your eyes, get immediate medical attention.
- If any gasoline spills onto your skin, immediately wash with soap and water. Change clothing if gasoline spills on it.

**CAUTION:**

**Use only fresh gasoline that has been stored in clean containers.**

Recommended gasoline:

Regular unleaded gasoline with a minimum octane rating of

86 (Pump octane number) =  $(R+M)/2$

90 (Research octane number)

EJU01043

**Gasohol**

There are two types of gasohol: gasohol containing ethanol and that containing methanol.

Gasohol containing ethanol can be used if ethanol content does not exceed 10 % and the fuel meets minimum octane ratings.

Gasohol containing methanol is not recommended by Yamaha because it can cause fuel system damage or engine performance problems.

EJU01044

**2-stroke engine oil**

Recommended engine oil:

YAMALUBE 2-W

If YAMALUBE 2-W is not available, another 2-stroke engine oil with an NMMA-certified TC-W3 rating may be used.

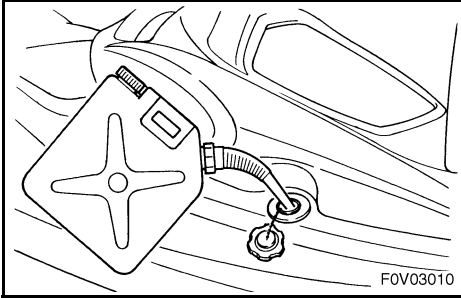

EJU01045

## Filling the fuel tank

### CAUTION:

**Be careful when refueling. Avoid getting water or other contaminants in the fuel tank. Contaminated fuel can cause poor running or engine damage.**

1. Open the hood and remove the front storage compartment, to check the fuel level. (See page 2-29 for front storage compartment.)
2. Open the fuel tank filler cap, and slowly add fuel to the fuel tank.
3. Stop filling when the fuel just reaches the bottom of the filler tube on the fuel tank. Do not fill into the filler tube, because fuel could spill out.

#### Fuel tank capacity:

Total: 70 L (18.5 US gal, 15.5 Imp gal)

Reserve: 12 L (3.2 US gal, 2.7 Imp gal)



EJU01240

## Filling the oil tank

### **⚠ WARNING**

- Do not add gasoline to the oil tank. Fire or explosion could result.
- Oil in the bilge is a serious fire hazard. Wipe up any spilled oil immediately.

### **CAUTION:**

Do not allow the oil tank to become completely empty. If the oil tank becomes empty the oil injection pump must be bled to ensure proper oil flow, otherwise engine damage may occur. If bleeding of the oil pump is necessary, have a Yamaha dealer bleed it.

1. Open the hood to access the oil tank filler cap. Also, remove all seats to watch the oil level. (See page 2-7 for hood, and 2-5 and 2-6 for rear and front seat.)
2. Open the oil tank filler cap, and very slowly add engine oil to the oil tank.
3. Stop pouring when the oil just reaches the bottom of the filler tube.

Oil tank capacity:  
5.5 L (1.5 US gal, 1.3 Imp gal)

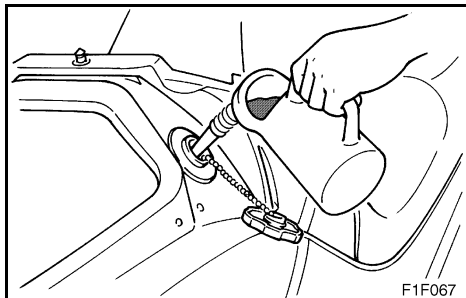



EJU01346

## Pre-operation checks

EJU01349

### Pre-operation check list

Before operating this watercraft, perform the checks in the following check list. See the accompanying text in this chapter for details on how to perform the checks.

#### **⚠ WARNING**

**If any item in the pre-operation check list is not working properly, have it inspected and repaired before operating the watercraft, otherwise an accident could occur.**

ITEM	ROUTINE	PAGE
Engine compartment	Remove all seats and front storage compartment to ventilate engine compartment. Check for fuel vapors or loose electrical connections	3-6
Bilge	Check for water and fuel residue and remove if necessary	3-7
Throttle	Check that the throttle lever springs back	3-10
Steering system	Check for proper steering system operation	3-10
Shift lever and reverse gate	Check for proper operation	3-11
Fuel and oil	Check fuel and oil level and add if necessary Check hoses and tanks for leakage	3-6
Water separator	Check for water and drain if necessary	3-7
Battery	Check electrolyte level and battery condition	3-8
Front and rear seats	Check that the seats are properly secured	2-5, 2-6
Hull/Deck	Check the hull and deck for cracks or other damage	—
Jet unit	Check for debris and remove if necessary	3-12
Fire extinguisher	Check the condition and replace if necessary	3-9
Engine shut-off cord	Check condition and replace if frayed or broken	3-12
Switches	Check the start switch, engine stop switch and engine shut-off switch for proper operation when the watercraft is in the water	3-13
Cooling water pilot outlet	Check that water is discharged while the engine is running and the watercraft is in the water	3-13
Multifunction meter	Check for warning indications and proper operation	3-13

#### **NOTE:**

Pre-operation checks should be made thoroughly each time the watercraft is used. This procedure can be completed in a short time. It is worth the time spent to assure safety and reliability.

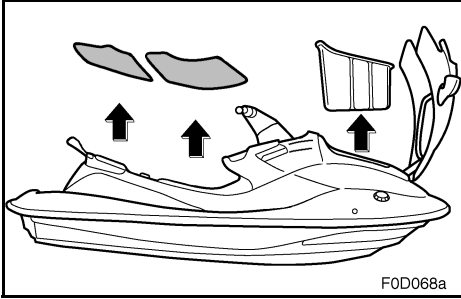

EJU01048

## Pre-operation check points

EJU01241

### Engine compartment

Ventilate the engine compartment before each use.

To ventilate the engine compartment, remove all seats and front storage compartment. (See pages 2-5 and 2-6 for front and rear seat, and 2-29 for front storage compartment.) Allow the engine compartment to remain open for a few minutes to allow any fuel vapors to escape. Also, check for loose electrical connections.

#### **⚠WARNING**

**Failure to ventilate the engine compartment could result in fire or explosion. Do not start the engine if there is a fuel leak or a loose electrical connection.**

EJU01242

### Fuel and oil systems

Check the fuel system for leakage, cracks or malfunctions before each use. (See page 4-9 for check points and correct procedures.)

1. Remove the fuel tank filler cap to release any pressure that might have built up in the fuel tank.
2. Remove all seats and front storage compartment. (See pages 2-5 and 2-6 for front and rear seat, and 2-29 for front storage compartment.)
3. Check the fuel and oil levels in the tanks and replenish if necessary. (See pages 3-3 and 3-4 for filling instructions.)

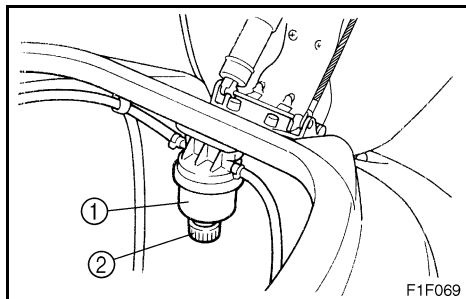

EJU01052

### Water separator

Check the water separator ① for water. Normally the water separator is empty. The water separator retains any water entering through the fuel tank breather hose if the watercraft is capsized.

If water remains in the water separator, drain it by removing the drain screw ②. Install the drain screw again after draining the water separator.

EJU01053

### Bilge

Check for moisture and fuel residue in the bilge.

Excessive water in the bilge can splash into the carburetor and engine which could cause engine damage.

#### To remove water from the bilge:

1. Remove the stern drain plugs.
2. Raise the bow of the watercraft until the water drains.
3. After the water has drained, wipe the bilge with dry rags to make sure that the bilge is thoroughly dry.
4. Install the drain plugs.

#### CAUTION:

- Make sure that the stern drain plugs are tightened securely before launching the watercraft.
- Clean any foreign materials, such as dirt or sand, from the drain plug threads before installing the drain plugs.

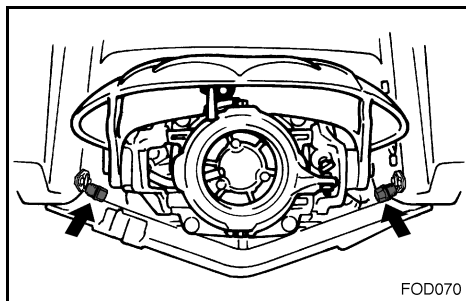





EJU01054

## Battery

Check the battery condition and the electrolyte level.

Check that the battery leads are tightened securely and there is no corrosion on the battery terminals.

### **⚠WARNING**

**The battery must always be fully charged and in good condition. Loss of battery power may leave you stranded. Never operate the watercraft if the battery does not have sufficient power to start the engine or if it shows any other signs of decreased power.**

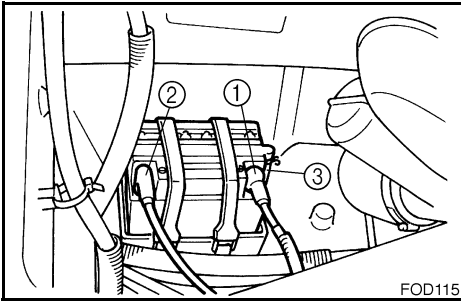

Make sure that the breather hose is properly connected and that it is not damaged or obstructed.

Make sure that the battery is securely held in place.

- ① Positive (+): Red lead
- ② Negative (-): Black lead
- ③ Breather hose

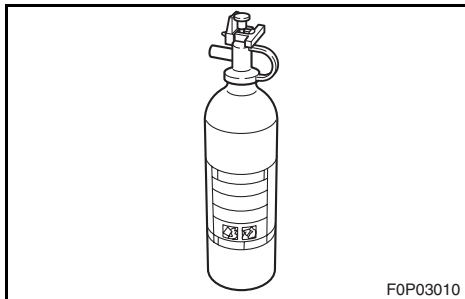

EJU01243

## Fire extinguisher

Check that there is a full fire extinguisher on board. The fire extinguisher container ① is located in the front storage compartment.

To open the fire extinguisher container cap ② turn it counterclockwise.

After inserting the fire extinguisher make sure that the container cap is tightened securely.

### NOTE:

- See the instructions supplied by the fire extinguisher manufacturer for checking the fire extinguisher. Always keep the extinguisher in the fire extinguisher container.
- Always carry a fire extinguisher on board. A fire extinguisher is not standard equipment with this watercraft. If you do not have one, contact a Yamaha dealer or a fire extinguisher dealer to obtain one meeting the proper specifications.

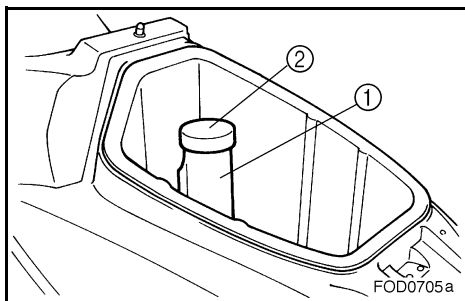

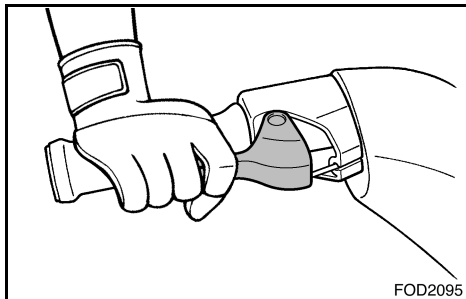

EJU01056

## Throttle

Squeeze and release the throttle lever several times to make sure that there is no hesitation in its travel. It should be smooth over the complete range, and spring back to the idle position when released.

### **⚠WARNING**

**Before starting the engine, always check the operation of the throttle lever. It should move smoothly through its full range of operation, and should spring back to the idle position when released.**

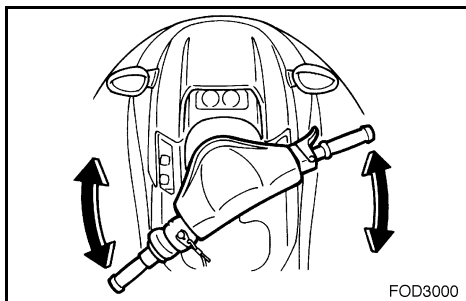

EJU01244

## Steering system

Check for looseness in the handlebars.

Turn them as far as possible to the right and left to make sure that operation is smooth and unrestricted throughout the whole range. Make sure that the jet thrust nozzle also changes directions as the handlebars are turned, and that there is no free play between the handlebars and the jet thrust nozzle.

Check that the tilt adjustment is locked in position. (See Tilt lever on page 2-13.)

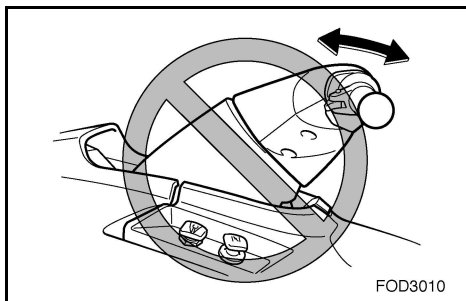

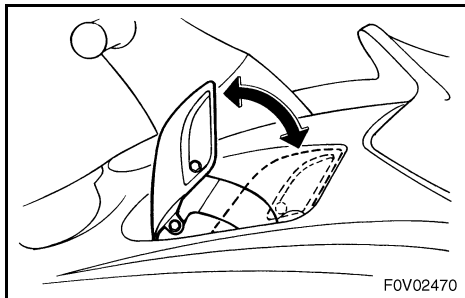

EJU01245

### Shift lever and reverse gate

Check for proper operation of the shift lever and reverse gate.

Make sure that the reverse gate goes down to its stopper position when the shift lever is pulled up.

Also, make sure that the reverse gate goes up to its stopper position when the shift lever is pushed down.

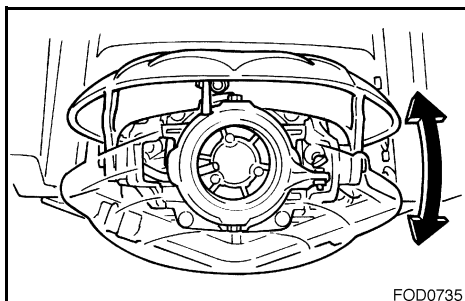

### **⚠WARNING**

- Make sure that the throttle is completely released and that the engine is at idle before shifting into reverse.
- Do not use the reverse function to slow down or stop the watercraft as it could cause you to lose control, be ejected, or impact the handlebars.
- Use reverse for slow-speed maneuvering only.
- Make sure that there are no obstacles or people behind you before shifting into reverse.
- Do not touch the reverse gate while the shift lever is being operated, otherwise you could be pinched.

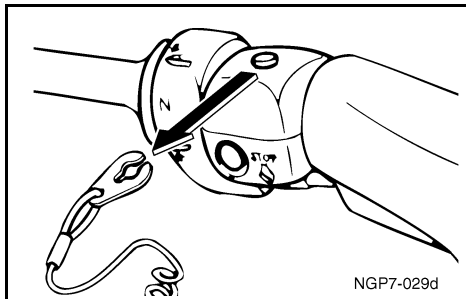

EJU01058

### Jet unit

Carefully check the jet intake for weeds, debris, or anything else that might restrict the intake of water. If the intake is clogged, cavitation could occur, reducing jet thrust, and possibly damaging the jet pump.

In some cases, the engine may overheat because of lack of cooling water, and damage to the engine could result. Engine cooling water is fed to the engine by the jet pump. (See page 5-4 for jet intake cleaning procedures.)

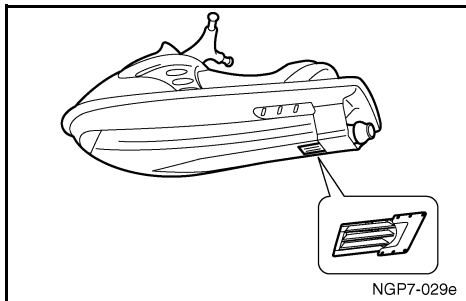

### **⚠ WARNING**

- Keep away from intake grate while engine is on. Items such as long hair, loose clothing, or PFD straps can become entangled in moving parts resulting in severe injury or drowning.
- Stop the engine and remove the clip from the engine shut-off switch before removing any debris or weeds, which may have collected around the jet intake.

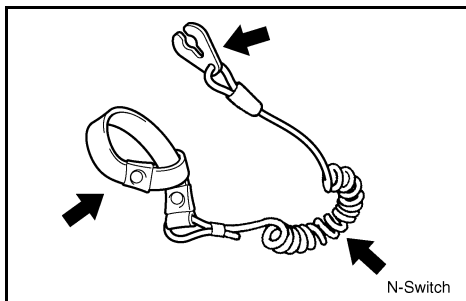

EJU01059

### Engine shut-off cord (lanyard)

Check that the engine shut-off cord is not frayed or broken. If the cord is damaged, replace it; never try to repair it or tie it together.

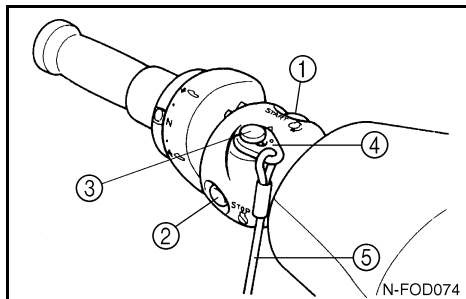

EJU01060

**Switches**

Check the start switch ①, the engine stop switch ②, and the engine shut-off switch ③ for proper operation.

To check these switches place the watercraft in the water to provide adequate cooling. Start the engine, and then pull the engine shut-off cord ⑤ to remove the clip ④ from the engine shut-off switch. Verify that the engine stops immediately. (See pages 3-16 to 3-19 for information on proper operation of the start switch, the engine stop switch and the engine shut-off switch.)

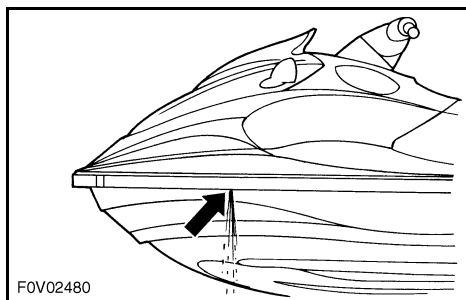

EJU01061

**Cooling water pilot outlet**

Check that water comes out from the outlets while the engine is running and the watercraft is in the water.

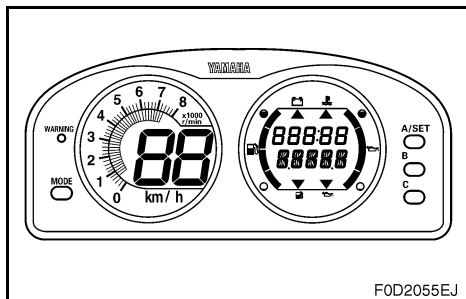

EJU01246

**Multifunction meter**

Check the operation of the multifunction meter. (See pages 2-19 to 2-28 for operation of the meter.)



EJU01063

## Operation

### **⚠ WARNING**

Before operating your watercraft, become familiar with all controls. Consult your Yamaha dealer about any control or function you do not fully understand. Failure to understand how controls work could cause an accident or prevent you from avoiding an accident.

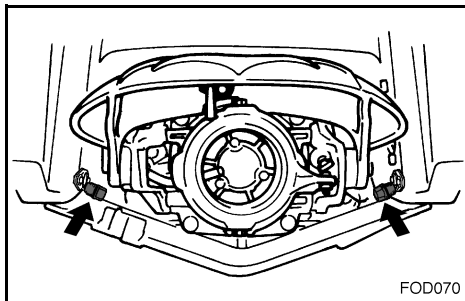

### **CAUTION:**

Make sure that stern drain plugs are securely tightened before launching the watercraft.

EJU01064

## Engine break-in

The engine break-in period is essential to allow the various components of the engine to wear and polish themselves to the correct operating clearances. This ensures proper performance and promotes longer component life.

### **CAUTION:**

- For the first tankful of operation, pre-mix a 50:1 mixture of fuel and oil (in addition to the oil in the oil tank).
- After break-in, use straight gasoline for normal operation.

1. Launch the watercraft and start the engine. (See pages 3-16 to 3-18 for engine starting procedures.)
2. Run the engine at the lowest possible speed for 5 minutes.



3. Gradually open the throttle to 3/4 or less.
4. Continue operation at 3/4 throttle or less until the first tankful of fuel has been used.
5. Fill the tank with straight gasoline, and then proceed with normal operation.

**CAUTION:**

**Failure to follow the engine break-in procedure properly can result in severe damage to the engine.**





EJU01247

## Launching the watercraft

Make sure that there are no obstructions behind you.

After the watercraft is in the water, start the engine. Shift into reverse and move the watercraft back slowly. If there are waves, someone should make sure that the watercraft is not pushed into the trailer before backing away.

EJU01248

## Starting the engine

### **⚠WARNING**

**Never start the engine or let it run for any length of time in an enclosed area. Exhaust fumes contain carbon monoxide, a colorless, odorless gas that may cause loss of consciousness and death within a short time. Always operate the watercraft in an open area.**

1. Launch the watercraft in water free from weeds and debris and at least 60 cm (2 ft) deep.

### **⚠WARNING**

**Never operate in water that is less than 60 cm (2 ft) deep, otherwise you increase your chance of hitting a submerged object, which could result in injury.**

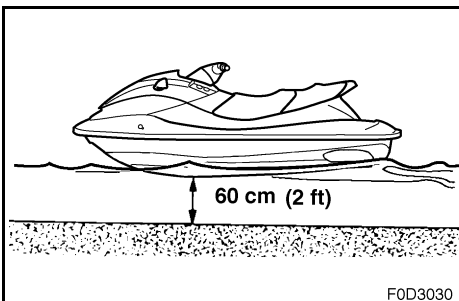

### **CAUTION:**

**Never operate in water that is less than 60 cm (2 ft) deep, otherwise pebbles or sand could be sucked into the jet intake, causing impeller damage or engine overheating.**

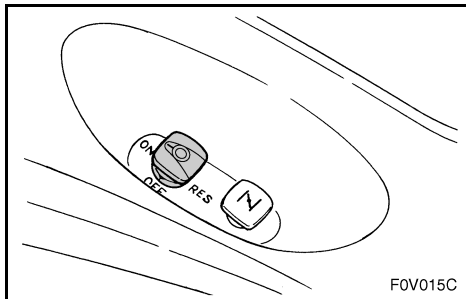

2. Turn the fuel cock knob to the “ON” position.

**NOTE:** \_\_\_\_\_  
Before starting the watercraft, after it has been sitting, remove the fuel tank filler cap to release any built-up pressure in the tank due to fuel expansion.

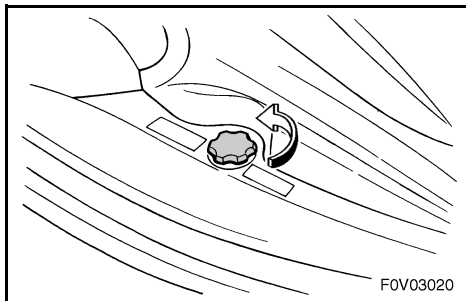

3. Attach the clip ① to the engine shut-off switch ②. Also, attach the engine shut-off cord ③ to your left wrist.

**⚠WARNING** \_\_\_\_\_

**Check that the engine shut-off cord is not frayed or broken, and keep it free from the handlebars so the engine stops if the operator falls off. The engine shut-off cord may not pull free if wrapped around the handlebars when the operator falls off, allowing the watercraft to continue to run and cause an accident.**

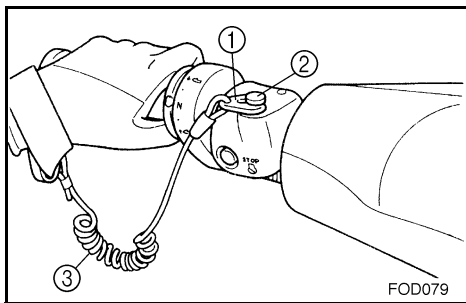

**NOTE:** \_\_\_\_\_  
It is not possible to start the engine with the clip removed from the engine shut-off switch.

4. Pull and hold the choke knob all the way out to start a cold engine.

**NOTE:** \_\_\_\_\_  
The choke should not be used when the engine is warm.

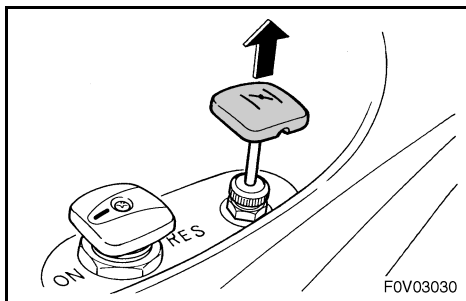



- If the "LOCK" mode was chosen previously, choose the "START" mode before starting the engine. (See pages 2-21 to 2-22 for selecting "PADLOC" mode.)

**NOTE:**

- If the initial setting of the PADLOC has not been done, the "START" mode is automatically selected.
- If you have previously chosen "LOCK" mode, the engine will not start unless the correct code is entered. This selects the "START" mode.

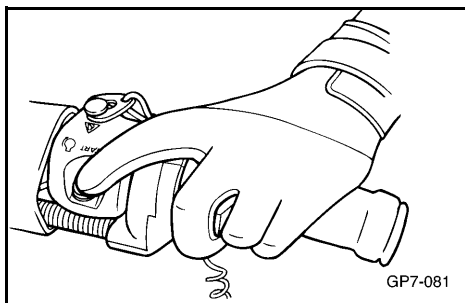

- While lightly squeezing the throttle lever, push the start switch (green button).

**⚠ WARNING**

On this watercraft, the engine is connected directly to the jet pump. Starting the engine immediately generates some thrust. Apply only enough throttle to keep the engine running.

- Release the start switch as soon as the engine starts to run.

**CAUTION:**

- Never push the start switch while the engine is running.
- Do not operate the start switch for more than 5 seconds, otherwise the battery will be discharged and the engine will not start. Also, the starter motor may be damaged. If the engine does not start in 5 seconds, release the start switch, wait 15 seconds, and try again.

- After the engine has warmed up, push the choke knob in to its original position.

**NOTE:**

If the choke knob is left pulled out, the engine will stall.

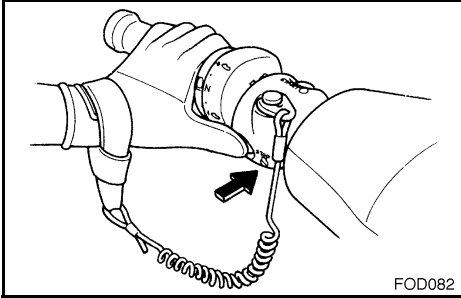

EJU01066

## Stopping the engine

To stop the engine, release the throttle lever, and then push the engine stop switch (red button).

### **⚠WARNING**

**You need throttle to steer. Shutting off the engine can cause you to hit an obstacle you are attempting to avoid. A collision could result in severe injury or death.**

EJU01249

## Leaving the watercraft

If leaving the watercraft, choose the “LOCK” mode on the multifunction meter by setting PADLOC, and remove the engine shut-off cord to reduce the chance of accidental starting or unauthorized use by children or others.

To set the mode, see PADLOC under Multifunction meter.



EJU01068

## Operating your watercraft

EJU01250

### Getting to know your watercraft

Operating your watercraft requires skills acquired through practice over a period of time. Take the time to learn the basic techniques well before attempting more difficult maneuvers.

Operating your new watercraft can be a very enjoyable activity, providing you with hours of pleasure. However, it is essential to familiarize yourself with the operation of the watercraft to achieve the skill level necessary to enjoy riding safely. Before operating this watercraft, read this Owner's/Operator's Manual, the Riding Practice Guide, and all warning and caution labels on the watercraft. Pay particular attention to the safety information on pages 1-9 to 1-16. These materials should give you an understanding of the watercraft and its operation.

Remember: This watercraft is designed to carry the operator and up to 2 passengers. Never exceed the maximum load limit or allow more than 3 persons (or 2 persons if a water-skier is being pulled) to ride the watercraft at one time.

Maximum load: 240 kg (530 lb)  
Load is the total weight of cargo, operator and passengers.

EJU01070

### Learning to operate your watercraft

Before operating the watercraft, always perform the pre-operation checks listed on page 3-5. The short time spent checking the watercraft will reward you with added safety and reliability.

Check all local laws before operating your watercraft.

Operate defensively at safe speeds and keep a safe distance away from people, objects, and other watercraft. Select a wide area to learn in, where you have good visibility and light boat traffic.

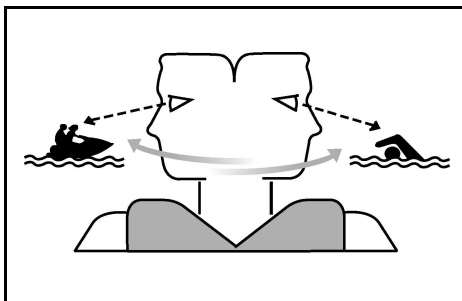

Use the buddy system—operate with someone nearby. Scan constantly for people, objects, and other watercraft. Be alert for conditions that limit your visibility or block your vision of others.

Attach the engine shut-off cord (lanyard) to your wrist and keep it free from the handlebars so that the engine stops if the operator falls off.

Wear a personal flotation device (PFD). All riders must wear an authority-approved PFD that is suitable for personal watercraft use.



Wear protective clothing. Severe internal injuries can occur if water is forced into body cavities as result of falling into the water or being near the jet thrust nozzle. Normal swimwear does not adequately protect against forceful water entry into rectum and vagina. All riders must wear a wetsuit bottom or clothing that provides equivalent protection.

Such clothing includes thick, tightly woven, sturdy and snug-fitting apparel such as denim, but does not include spandex or similar fabrics like those used in bicycle shorts. A full wetsuit can also protect against hypothermia (subnormal body temperature) and abrasions.

Footwear and gloves are recommended.

Eye protection is recommended to keep wind, water, and glare from the sun out of your eyes while you operate your watercraft. Restraining straps for eyewear are made which are designed to float should your eyewear fall in the water.

You should grip the handlebars firmly and keep both feet on the floor of the footwell. Do not attempt to ride with passengers until your operating skills are fully developed.

EJU01251

## Riding watercraft with passengers

When 2 or 3 persons (including the operator) are on board, the watercraft handles differently, and is not as easy to maneuver, so operating it requires a higher degree of skill. Before attempting to operate the watercraft with passengers on board, the operator must practice operating the watercraft alone enough to be able to acquire the necessary skills.

The passengers must always wear the authority-approved PFD and wetsuit bottom or equivalent.

### **⚠WARNING**

**Do not apply throttle when anyone is at rear of watercraft. Turn engine off or keep engine at idle. Water and/or debris exiting the jet thrust nozzle can cause severe injury. Passengers should not attempt to board the watercraft if the operator is applying throttle.**

Do not give a ride to children whose feet cannot reach the floor of the footwell. Passengers should hold on firmly to the person in front of them and keep both feet in the footwell.

### **⚠WARNING**

**When passengers are on board, make sure that they are holding on firmly and have feet in the footwell before you start to accelerate.**

When pulling a skier, the spotter should face to the rear while holding the handgrip with both hands. The spotter should always sit astride the seat with his or her feet placed firmly on the footrest for proper balance. Follow state laws regarding skiing such as skier-down flags, rearward-facing spotter, and other requirements.



EJU01072

## Starting the watercraft

### **⚠ WARNING**

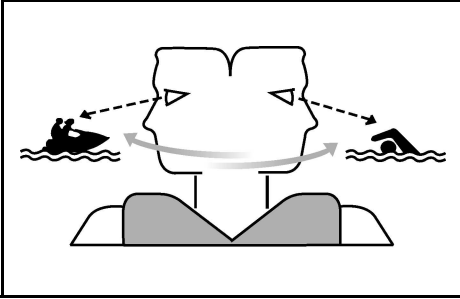

- Scan constantly for people, objects and other watercraft. Be alert for conditions that limit your visibility or block your vision of others.
- Operate defensively at safe speeds and keep a safe distance away from people, objects, and other watercraft.
- Do not follow directly behind watercraft or other boats. Do not go near others to spray or splash them with water. Avoid sharp turns or other maneuvers that make it hard for others to avoid you or understand where you are going. Avoid areas with submerged objects or shallow water.
- Take early action to avoid collisions. Remember watercraft and other boats do not have brakes. Do not release the throttle when trying to steer away from objects—you need throttle to steer.
- Practice reboarding in shallow water before riding in deep water.

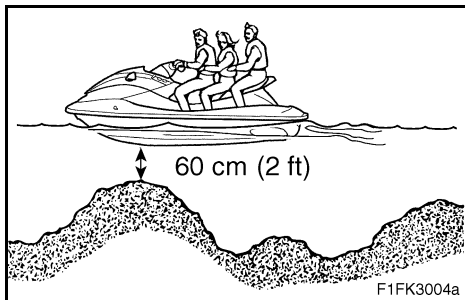

EJU01073

### Starting and boarding in shallow water

1. Do not start the engine in less than 60 cm (2 ft) of water. Put the watercraft in water that is deep enough, and then board the watercraft from the side or the rear.
2. Attach the engine shut-off cord to your left wrist, and then install the clip to the engine shut-off switch.
3. Grip the handlebars with both hands, place both feet on the floor of the foot-well, start the engine, and start off.

EJU01074

### Starting from a dock

1. Board the watercraft from the side.
2. Attach the engine shut-off cord to your left wrist, and then install the clip to the engine shut-off switch.
3. Push the watercraft away from the dock, grip the handlebars with both hands, place both feet on the floor of the foot-well, start the engine, and start off.





EJU01075

## Boarding and starting in deep water

### **⚠WARNING**

- Operator and passenger should practice getting on board in shallow water before riding in deep water. Boarding in deep water requires more skill.
- The fatigue and exposure that could result after unsuccessful attempts to get back on the watercraft may increase the risk of injuries and drowning.

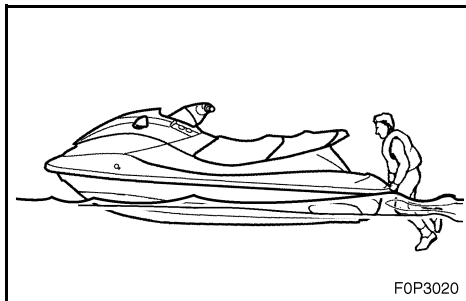

F0P3020

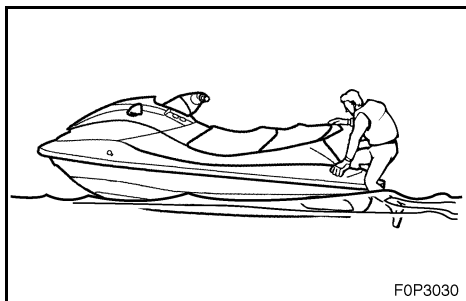

F0P3030

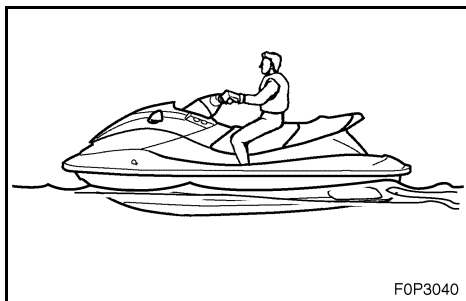

F0P3040

EJU01076

## Boarding alone

1. Swim to the rear of the watercraft and place both hands on the boarding platform, pull yourself up, and then grasp the handgrip with one hand.
2. Pull yourself up to a kneeling position on the platform, and then move to the seat and sit astride.
3. Attach the engine shut-off cord to your wrist, and then install the clip to the engine shut-off switch.
4. Grip the handlebars firmly with both hands, place both feet in footwell, start the engine, and look in all directions before starting off.

### **⚠WARNING**

**Before starting off, make sure that there are no boats, obstructions, or swimmers around you.**



EJU01252

## Boarding with passengers

### **⚠WARNING**

Severe internal injuries can occur if water is forced into body cavities as a result of being near the jet thrust nozzle. Do not apply throttle until each passenger is seated with his or her feet on the floor of the footwell and is holding on to the person in front of him or her.

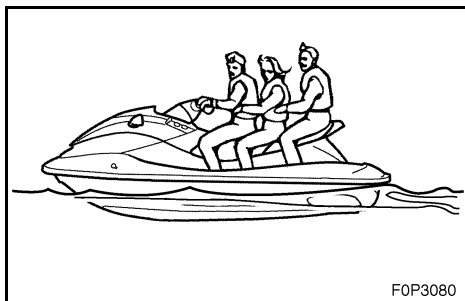
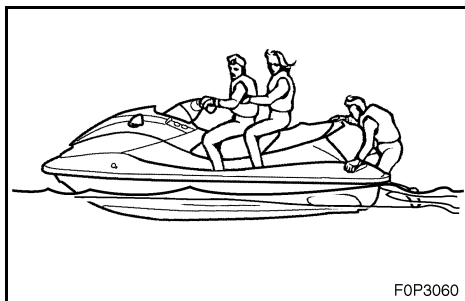
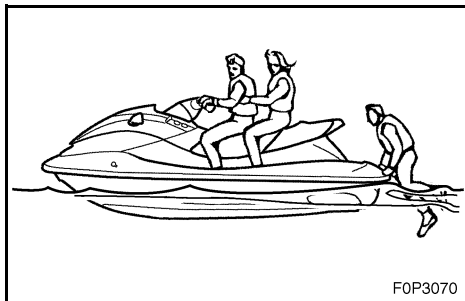
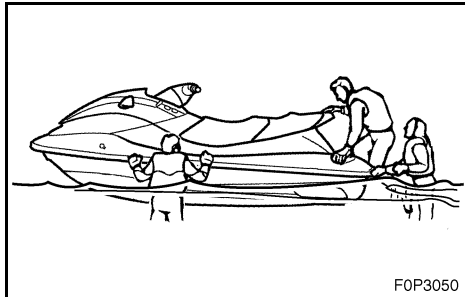

1. Climb on board as noted in the previous section, and sit astride the seat. Attach the engine shut-off cord to your wrist, and then install the clip to the engine shut-off switch.
2. Have the passenger move to the rear of the watercraft.
3. Have the passenger get on board and sit on the seat. If a second passenger is getting on, have him or her follow the same procedure.

### **NOTE:**

When a passenger is getting on board, both he and the operator should try to balance the watercraft.

4. The operator should check to see that the passengers have their feet on the floor of the footwell and that they are securely holding on to the person in front of them.
5. Start the engine, look in all directions, and then accelerate to planing speed.

### **⚠WARNING**

Before starting off, make sure that there are no boats, obstructions, or swimmers around you.

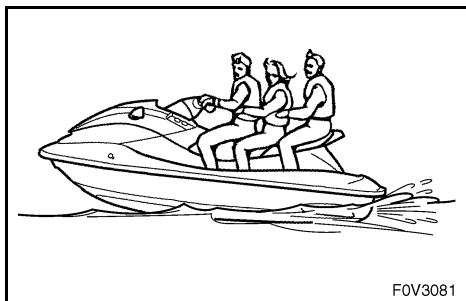
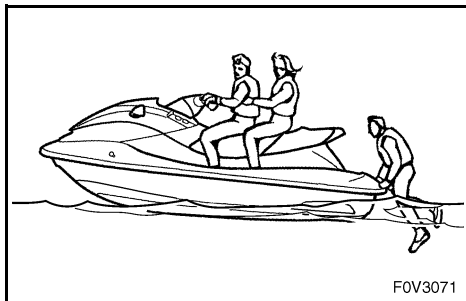
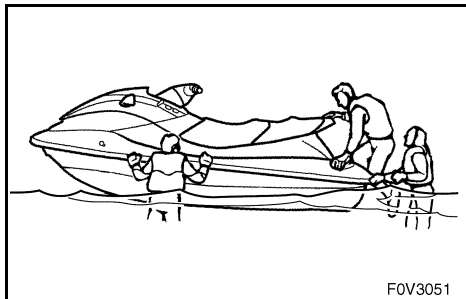
**NOTE:**

The heavier the total weight of the operator and passengers, the more difficult it will be to balance the watercraft. Do not operate the watercraft when the total weight exceeds 240 kg (530 lb) including any cargo. If it is difficult to balance the watercraft at a standstill, proceed as follows:

1. The passenger must steady the watercraft while the operator is boarding. The operator pulls himself up onto the platform into a seating position, then balances the watercraft.
2. Attach the lanyard to your left wrist, then install the clip on the lanyard to the engine shut-off switch. Start the engine and keep it at idle.
3. The passenger pulls himself up on the platform, kneels down, then crawls onto the seat as the watercraft accelerates.
4. The watercraft can now be accelerated to planing speed, then the operator can reduce the throttle to the desired running speed.

EJU01078

**Capsized watercraft**

If the watercraft capsizes, follow the procedures below carefully to prevent damage or injury.

**⚠ WARNING****IMPROPER UPRIGHTING CAN CAUSE INJURY:**

- Shut engine off, and be sure engine shut-off cord is removed from the engine shut-off switch.
- Do not put hand in intake grate.
- Watch so you are not hit by the watercraft as it comes over.

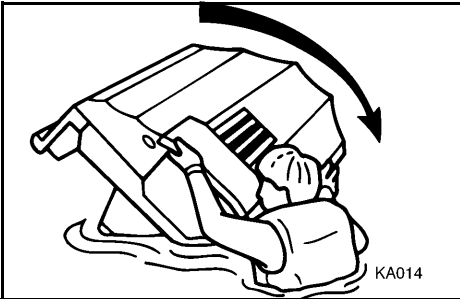
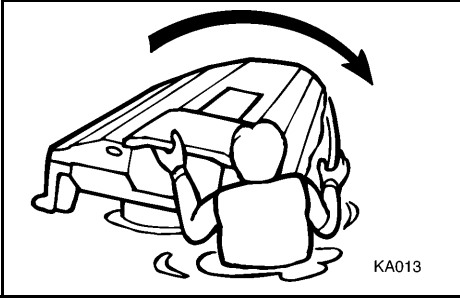
**CAUTION:**

Be sure to remove the clip from the engine shut-off switch, otherwise the engine will overheat and engine damage may occur.

1. Shut the engine off by removing the clip from the engine shut-off switch.
2. Swim to the rear of the watercraft. Pull the watercraft over with left hand on ride plate while pushing down on the gunwale with your right hand/foot.

**NOTE:**

If the port side of the capsized watercraft is tilting upward, first tilt the watercraft so the port side is down by using your weight to press down on the gunwale.

**CAUTION:**

Do not turn the watercraft over counter-clockwise, otherwise water may leak into the carburetor and engine and cause damage.

3. Start the engine, and then head for shore to inspect the engine for water damage.

**CAUTION:**

If the watercraft has been capsized for 5 minutes or more, air may have entered the oil injection system. Leave the engine off, or operate only at trolling speed, for 10 minutes after the watercraft has been turned right-side up. This will allow any air to bleed off.



EJU01079

## Turning the watercraft

Steering control depends on the combination of handlebar position and the amount of throttle.

Water sucked in through the intake grate is pressurized by the impeller in the jet pump. As the pressurized water is expelled from the pump through the jet thrust nozzle, it creates thrust to move and steer the watercraft. The higher the engine speed, the more thrust is produced.

The amount of jet thrust, in addition to the position of the handlebars, determines how sharply you turn.

- A. More throttle produces higher thrust, so the watercraft will turn more sharply.
- B. Less throttle produces lower thrust, so the watercraft will turn more gradually.
- C. Releasing the throttle completely produces only minimum thrust. If you are traveling at speeds above trolling, you will have rapidly decreasing ability to steer without throttle. You may still have some turning ability immediately after releasing the throttle, but once the engine slows down, the watercraft will no longer respond to handlebar input until you apply throttle again or you reach a trolling speed.

At trolling speed, the watercraft can be turned gradually by handlebar position alone using just the amount of thrust available at idle.

- D. If the engine is stopped while riding, there is no thrust. The watercraft will go straight even though the handlebars are turned.

**You need throttle to steer.**

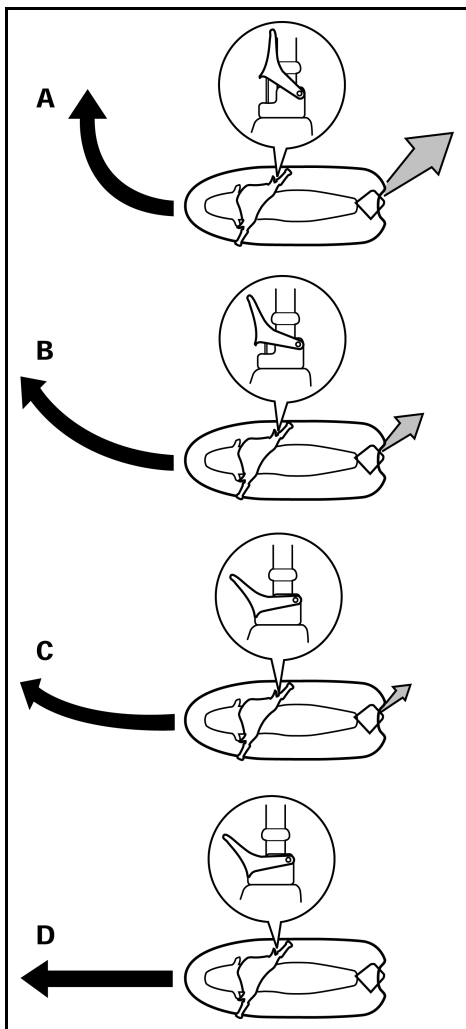
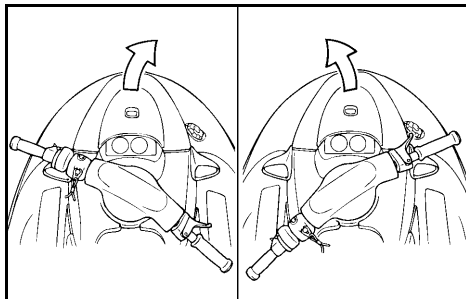

**⚠ WARNING**

- Do not release the throttle when trying to steer away from objects—you need throttle to steer. A collision could result in severe injury or death.
- When operating at higher speeds, make gradual turns or slow down before turning. Sharp high-speed turns may cause the watercraft to slide sideways or spin, throwing the operator and passengers overboard which could cause an injury.



EJU01253

## Stopping the watercraft

The watercraft is not equipped with a separate braking system. It is stopped by water resistance when the throttle lever is released. From full speed, the watercraft comes to a complete stop in approximately 110 m (360 ft) after the throttle is released and the engine is stopped, although this distance will vary depending on many factors, including gross weight, water surface conditions, and wind direction. The watercraft slows down as soon as the throttle lever is released, but will coast for a distance before fully stopping. If you are not sure you can stop in time before hitting an obstacle, apply throttle and turn in another direction.

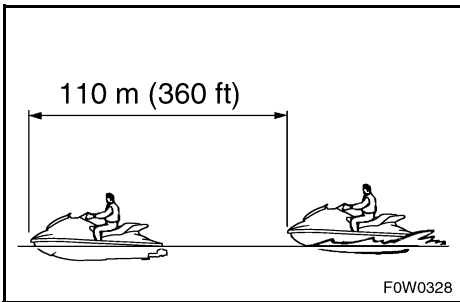

### **⚠ WARNING**

- Allow adequate stopping distance.
- Take early action to avoid collisions. Remember, watercraft and other boats do not have brakes.
- Operate defensively at safe speeds and keep a safe distance away from people, objects, and other watercraft to give you time to stop.
- Do not shut the engine off when slowing down in case you need engine power to steer away from a boat or other obstacle that comes into your path.

### **⚠ WARNING**

Do not use the reverse function to slow down or stop the watercraft as it could cause you to lose control, be ejected, or impact the handlebars.



EJU01081

## Beaching the watercraft

1. Make sure no obstructions, boats or swimmers are near the beach. Release the throttle lever about 110 m (360 ft) before you reach the intended beaching area.
2. Approach the beach slowly and stop the engine before reaching land.  
Remember: you need throttle to steer.
3. Get off the watercraft and pull it up on the beach.

### **CAUTION:**

**Small pebbles, sand, seaweed, and other debris can be pulled into the jet intake and impair or damage the impeller. Always stop the engine and get off before beaching the watercraft.**

EJU01082

## Docking the watercraft

1. Make sure that no obstructions, boats or swimmers are close to the watercraft. Reduce speed about 110 m (360 ft) away from the dock.
2. Slowly approach the dock and stop the engine just before coming alongside it.





EJU01254

## Reverse on waterways

Reverse can be used for slow speed maneuvering when it is necessary to back up out of tight spots where you cannot turn around. Reverse can only be used to slow down or stop during low speed maneuvering, such as when docking.

Once the engine is idling, shift to reverse and gradually increase engine speed. Make sure that there are no obstacles or people behind you before shifting to reverse.

EJU01255

## Rough water operation

The force of landing after jumping can cause a strong impact on both the watercraft and the operator and passengers. It is possible for the operator to hit his or her chest or jaw on the watercraft body or handlebars and be injured. Do not operate the watercraft with your chin right above the handlebars or with your feet outside the watercraft. Operating in rough water or jumping waves can also crack the watercraft body or damage internal parts. Avoid operating in rough water or bad weather conditions.



EJU01084

## Post-operation checks

Always perform the following post-operation checks after operating the watercraft.

1. Remove the watercraft from the water.
2. Wash down the hull, handlebars, and jet unit with fresh water.
3. Remove the seat and check the engine compartment for water. To drain excess water, remove the stern drain plugs, then raise the bow of the watercraft enough to allow water in the bilge to drain out.

**NOTE:**

This watercraft is equipped with an automatic bilge-draining system that removes water from the engine compartment while you are underway. However, some residual water will remain.

4. Put the watercraft in a horizontal position.
5. Flush the cooling system to prevent it from clogging with salt, sand, or dirt. (See page 4-1 for flushing the cooling system procedures.)
6. Drain residual water from the exhaust system by alternately squeezing and releasing the throttle lever for 10 to 15 seconds while the engine is running.

**CAUTION:**

**Do not attempt to run the engine at full throttle or for more than 15 seconds while the watercraft is out of the water, otherwise the engine may overheat or seize.**

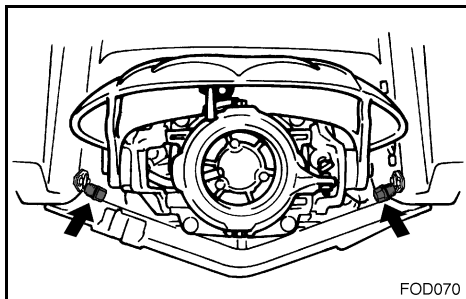



7. If the watercraft will be stored for a week or more, lubricate internal engine components to help prevent corrosion. (See page 4-3 for lubrication procedures.)
8. Rinse the engine and engine compartment with a small amount of water.

**CAUTION:**

**Do not use high pressure when rinsing the engine or engine compartment as severe engine damage could result.**

9. Wipe the engine and engine compartment dry with a clean cloth (repeat step 3, if necessary).
10. Wipe the hull, handlebars, and jet unit dry with a clean cloth.
11. Spray a rust inhibitor on metallic parts to minimize corrosion.
12. Allow the engine compartment to air dry completely before reinstalling the seat.



EJU01256

## Transporting

### **⚠ WARNING**

Always place the fuel cock knob in the “OFF” position when transporting the watercraft, otherwise fuel could leak out into the engine or engine compartment, which would create a fire hazard.

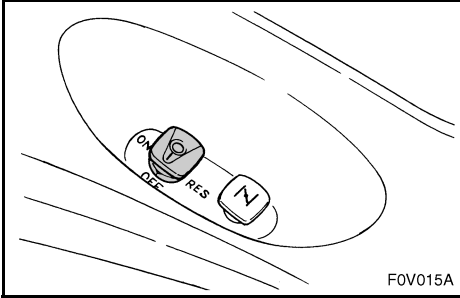

When transporting the watercraft on a trailer, secure the tie downs to the trailer through the bow eye and stern rope hole.

### **CAUTION:**

- Do not route ropes or tie downs over the seat, as they may leave permanent marks on the seat's surface. Also, wrap the ropes or tie downs with towels or rags where they touch the body of the watercraft to avoid scratching or damage.
- Before putting the watercraft on the trailer or transporting it, be sure to put the shift lever in the forward position, otherwise the reverse gate may hit an obstruction, which may cause damage.

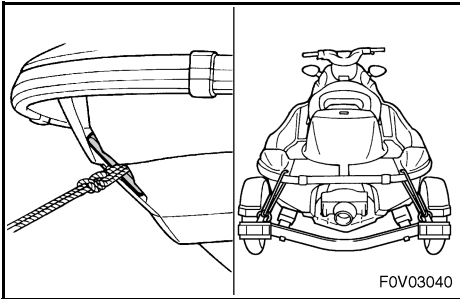

EJU01086

# MAINTENANCE AND CARE



<b>Storage</b> .....	4-1
Flushing the cooling system .....	4-1
Lubrication .....	4-3
Fuel system .....	4-4
Battery .....	4-5
Cleaning the watercraft .....	4-6
<b>Maintenance and adjustments</b> .....	4-7
Owner's/Operator's Manual and tool kit .....	4-8
Periodic maintenance chart.....	4-9
Inspecting the fuel system .....	4-10
Inspecting the oil injection system .....	4-12
Inspecting the steering cable .....	4-13
Inspecting the shift cable .....	4-13
Inspecting and adjusting the throttle cable .....	4-13
Inspecting the QSTS mechanism .....	4-14
Cleaning and adjusting the spark plugs .....	4-15
Lubrication points .....	4-16
Adjusting the choke cable .....	4-19
Inspecting the battery .....	4-20
Adjusting the carburetor .....	4-22
Replacing the fuse .....	4-23
Bleeding the oil injection pump .....	4-23
<b>Specifications</b> .....	4-24



EJU01087

## Storage

### **⚠ WARNING**

Always place the fuel cock knob in the “OFF” position when storing the watercraft, otherwise fuel could leak out into the engine or engine compartment, which would create a fire hazard.

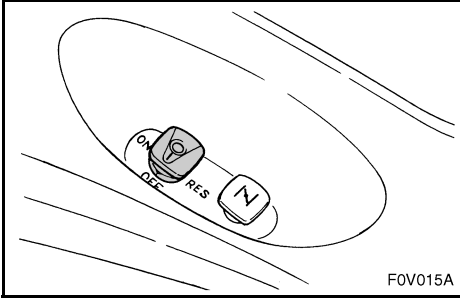

Storage for prolonged periods of time, such as winter storage, requires preventative maintenance to ensure against deterioration. It is advisable to have the watercraft serviced by a Yamaha dealer prior to storage. However, the following procedures can be performed by the owner.

EJU01088

### **Flushing the cooling system**

Flushing the cooling system is essential to prevent the cooling system from being clogged with salt, sand, or dirt.

### **CAUTION:**

- Do not supply water to the cooling water passages when the engine is not running. The water could flow back through the muffler into the crankcase causing severe engine damage.
- Do not run the engine for more than 15 seconds without supplying water, otherwise the engine may overheat.

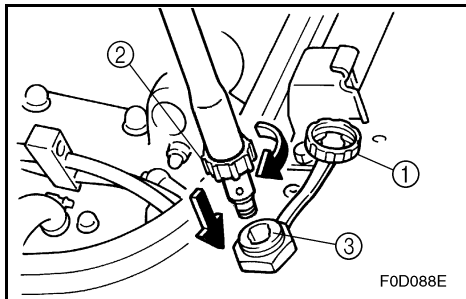

1. Put the watercraft on land in a horizontal position.
2. Open the flushing hose connector cap ①, and then insert the garden hose adapter ② into the flushing hose connector ③ and turn it until it is securely connected.
3. Connect the garden hose adapter to a water tap using a hose.
4. Start the engine, and then immediately turn the water supply on until water flows out continually from the cooling water pilot outlet.
5. Run the engine at idling speed for about 3 minutes watching the engine condition. If the engine stops while flushing, turn the water supply off immediately and repeat the above steps.
6. Turn the water supply off, and then force the remaining water out from the cooling passages by alternately squeezing, and releasing the throttle lever for 10 to 15 seconds.
7. Stop the engine.
8. Remove the garden hose adapter and secure the cap.



EJU01089

## Lubrication

1. Remove the spark plugs and pour approximately one tablespoon of oil into each cylinder.
2. Grease the spark plug threads and reinstall the spark plugs.
3. Crank the engine within 3 seconds using the start switch.
4. Lubricate all cables such as the throttle, choke, and steering cables.

**NOTE:** \_\_\_\_\_

Use a suitable marine grease applicator to pressure lubricate the cables and purge out any moisture between the inner and outer cables.

---

5. Lubricate the areas of the watercraft specified under Lubrication points on page 4-16.





EJU01090

## Fuel system

Draining the fuel system prevents buildup of varnishes and other harmful deposits that result when gasoline sits for a prolonged period of time.

### **⚠WARNING**

**Gasoline is highly flammable and explosive. A fire or explosion can cause severe injury or death. Shut the engine off. Drain in well-ventilated areas away from flames or sparks. Do not smoke. Avoid spilling gasoline. Wipe up spilled gasoline immediately.**

#### **To drain the fuel system:**

1. Place the fuel cock knob in the "OFF" position.
2. Drain the fuel tank using a siphon.



EJU01092

## Battery

If the watercraft is not used for a month or more, disconnect the (-) battery cable first, and then the (+) cable and breather pipe, and next remove the battery from the craft.

Clean the battery casing using fresh water.

If the battery terminals are dirty or corroded, clean the mating surfaces on the terminals for the battery cables using the wiring brush or equivalents.

Recharge the battery, and then store it in a cool and dark place.

Apply the Yamaha marine grease/Yamaha grease A to the battery terminals.

Recharge the battery periodically at least 2 months because a battery will discharge electricity by itself while storing.

### CAUTION:

**The battery may be impossible to use again if you store it for a longer time without recharging. Recharge the battery periodically.**

### NOTE:

The battery condition can be found by checking the specific gravity of the electrolyte. However, you can also know the battery condition roughly by measuring the voltage at both battery terminals. Recharge the battery if the voltage is 12 volts or less.

Specific gravity of electrolyte (for reference): 1.28 at 20 °C (68 °F)
--

Yamaha recommend checking the specific gravity of the electrolyte and charging battery by a Yamaha dealer or a battery dealer. If you maintain the battery yourself, read carefully the instructions for the tool and machine before maintenance.



EJU01093

## Cleaning the watercraft

Clean the watercraft before storing it for a long period.

1. Wash down the hull, handlebars, and drive unit with fresh water.
2. Rinse the engine and bilge area with fresh water. Drain off all water and wipe up remaining moisture with clean, dry rags.
3. Spray the engine's exterior with a rust inhibitor and lubricant.
4. Wax the hull with a non-abrasive wax.
5. Wipe all vinyl and rubber components, such as the seat and engine compartment seals, with a vinyl protectant.



## Maintenance and adjustments

Periodic inspection, adjustment and lubrication will keep your watercraft in the safest and most efficient condition possible. Safety is an obligation of the watercraft owner. The most important points of watercraft inspection, adjustment and lubrication are explained on the following pages.

See your Yamaha dealer for genuine Yamaha replacement parts and optional accessories designed for your watercraft.

Remember that failures that are the result of the installation of parts or accessories which are not qualitatively equivalent to genuine Yamaha parts are not covered by the limited warranty.

### **⚠ WARNING**

- **Be sure to turn off the engine when you perform maintenance unless otherwise specified, otherwise an accident or injury could result from unexpected operation, moving parts, or electric shock. If the owner is not familiar with watercraft servicing, this work should be done by a Yamaha dealer. Improperly serviced components could fail or stop operating correctly, which could result in an accident.**
- **Modifications to this watercraft not approved by Yamaha may cause loss of performance or excessive noise, or render it unsafe for use. Consult a Yamaha dealer before attempting any changes.**

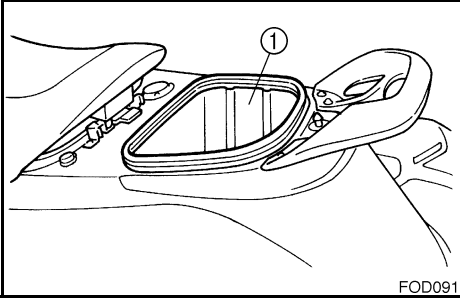

EJU01095

## Owner's/Operator's Manual and tool kit

It is advisable always to carry the Owner's/Operator's Manual and tool kit ② with you whenever you use the watercraft. For your convenience, a storage compartment ① is provided on the watercraft for the manual and tool kit.

### NOTE:

To protect these materials from water damage, it would be a good idea to put them in a waterproof bag.

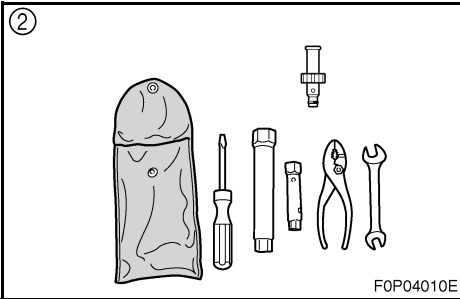

The service information included in this manual is intended to provide you with the necessary information for completing your own preventive maintenance and minor repairs. The tools provided in the tool kit are sufficient for this purpose. However, a torque wrench may also be necessary to tighten nuts and bolts.



EJU01357

## Periodic maintenance chart

The following chart gives general guidelines for periodic maintenance. However, depending on your operating conditions maintenance may need to be performed more frequently.

- (●) This mark indicates maintenance that you may do yourself.
- (○) This mark indicates work to be done by a Yamaha dealer.

MAINTENANCE INTERVAL  ITEM		INITIAL			THEREAFTER EVERY		PAGE
		10 hours	50 hours	100 hours	100 hours	200 hours	
			3 months	6 months	6 months	12 months	
Spark plug	Inspect, clean, adjust	●	●	●	●		4-15
Lubrication points	Lubricate			●	●		4-16
Intermediate housing	Lubricate	○*1		●*2	●*2		4-19
Fuel system	Inspect			○	○		4-10
Fuel filter	Check, replace	○				○	4-11
Fuel tank	Clean					○	4-11
Oil injection system	Inspect, clean	○				○	4-12
Trolling speed	Adjust			●	●		4-22
Carburetor throttle shaft	Inspect			○	○		—
Cooling water passages	Flush	● (after every use)					4-1
Bilge strainer	Clean		●	●	●		—
Impeller	Inspect		●	●	●		—
Steering cable	Inspect			●	●		4-13
Steering master	Inspect	○		○	○		—
QSTS mechanism	Inspect			●	●		4-14
Shift cable and mechanism	Inspect, adjust			●	●		4-13
Throttle cable	Inspect, adjust			●	●		4-13
Choke cable	Inspect, adjust			●	●		4-19
Stern drain plugs	Inspect, replace					●	3-7
Battery	Inspect	● (inspect fluid level before every use)					4-20
Rubber coupling	Inspect					○	—
Nuts and bolts	Retighten	○		○	○		—

\*1: Grease capacity: 33.0–35.0 cm<sup>3</sup> (1.11–1.18 oz)

\*2: Grease capacity: 6.0–8.0 cm<sup>3</sup> (0.20–0.27 oz)



EJU01383

## Inspecting the fuel system

### **⚠WARNING**

**Gasoline is highly flammable and explosive. A fire or explosion can cause severe injury or death. Shut off the engine. Do not smoke. Avoid spilling gasoline.**

Check the fuel system for leaks, cracks, or malfunctions. If any problem is found, do the necessary repair or replacement as required. If repair is necessary, consult a Yamaha dealer.

#### **Check:**

- Carburetor for leakage.
- Fuel pump for malfunction or leakage.
- Fuel tank for water or dirt.
- Fuel tank for damage, cracks or leakage.
- Fuel hose joint for leakage.
- Fuel hose for cracks or other damage.
- Fuel filter for leakage.
- Fuel cock for leakage.
- Air vent check valve for leakage.
- Fuel tank filler cap for damage.

### **⚠WARNING**

**Failure to check for and repair any fuel leakage may result in fire or explosion.**

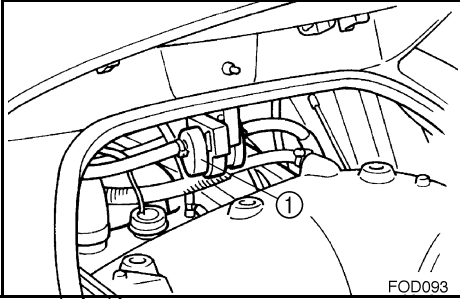

EJU01098

### Fuel filter

This watercraft is equipped with a one-piece, disposable fuel filter ①. The fuel filter should be replaced once a year or after every 200 hours of operation, or if water is found in the filter. Have a Yamaha dealer replace the fuel filter if necessary.

#### **⚠WARNING**

**Do not try to replace the fuel filter yourself. An incorrectly installed filter can leak gasoline, which could lead to fire or explosion. If necessary, have a Yamaha dealer replace the fuel filter.**

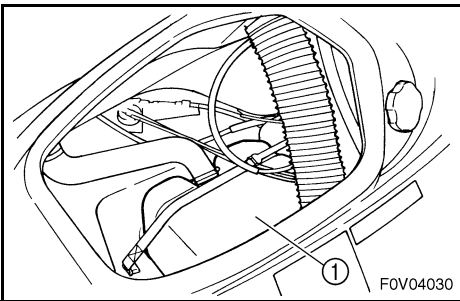

EJU01099

### Fuel tank

Check the fuel tank ① for leakage or water in the tank. If water is found in the fuel system or if the fuel tank needs to be cleaned have a Yamaha dealer service the watercraft.





EJU01100

## Inspecting the oil injection system

Check the oil injection system for leakage, cracks, or malfunctions. If necessary, have a Yamaha dealer repair the oil injection system.

### Check:

- Oil tank for damage, cracks or leakage.
- Oil tank for water or dirt.
- Oil hose and joint for damage or cracks.
- Oil filter for dirt.
- Oil pump for leakage.

EJU01101

### Oil tank

Check the oil tank for leakage or water in the tank. If water is found in the oil injection system or if the oil tank needs to be cleaned have a Yamaha dealer service the watercraft.

EJU01102

### Oil filter

Check the oil filter ① for dirt and clogs. If the oil filter is clogged, remove it from the oil tank together with the oil level sender and clean it.

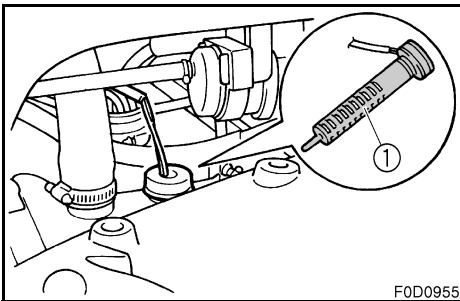

F0D0955

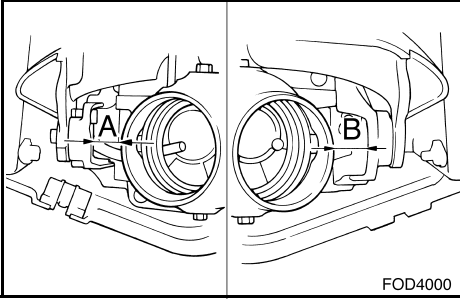

EJU01258

## Inspecting the steering cable

Check for smooth operation of the handlebars and jet thrust nozzle.

Turn the handlebars as far as possible to the right and left and check that the distance between the jet thrust nozzle and the bracket of the reverse gate are equal on right and left sides.

Distance A and B:  $A=B$

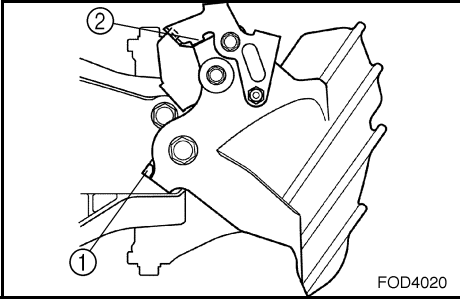

EJU01259

## Inspecting the shift cable

Place the shift lever in the reverse position.

Make sure the gate makes contact with the stopper ① on the bracket, and the arm ② makes contact with the reverse gate.

If the reverse gate does not reach the correct positions, have a Yamaha dealer service it.

EJU01104

## Inspecting and adjusting the throttle cable

Check that the throttle cable moves back to the set position smoothly and that free play is within specification.

1. Squeeze and release the throttle lever. If the lever does not return smoothly, have a Yamaha dealer service it.
2. Adjust free play ② by loosening the lock-nut ① and turning the adjuster ②.

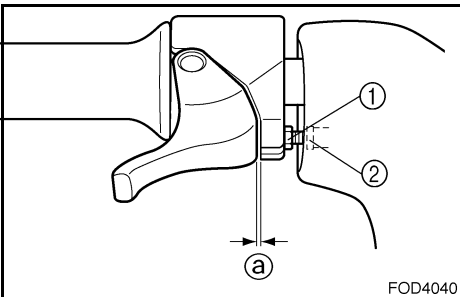

Throttle lever free play:  
4–7 mm (0.16–0.28 in)



EJU01105

## Inspecting the QSTS mechanism

Check that the shift lock lever moves back to the lock position smoothly, that the QSTS selector locks and unlocks properly, and that the jet thrust nozzle moves up or down.

1. Squeeze and release the shift lock lever.
2. Check that the QSTS selector locks and unlocks when the lever is released.
3. Check that the selector turns smoothly when the lever is squeezed and held in place.
4. Check that the angle of the jet thrust nozzle changes when the selector is shifted from neutral to bow-up or bow-down.

If the mechanism does not work properly, have a Yamaha dealer service it.

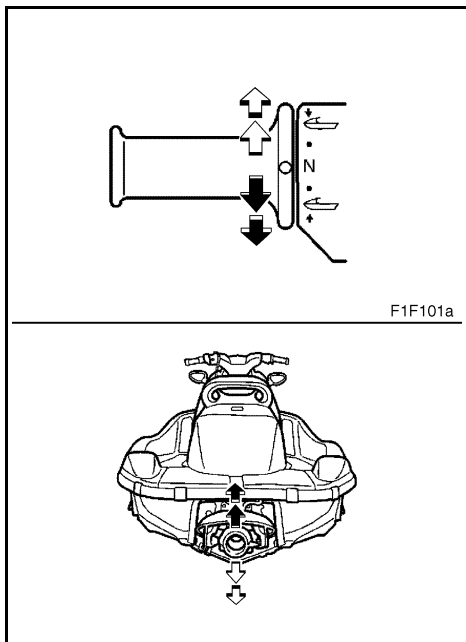
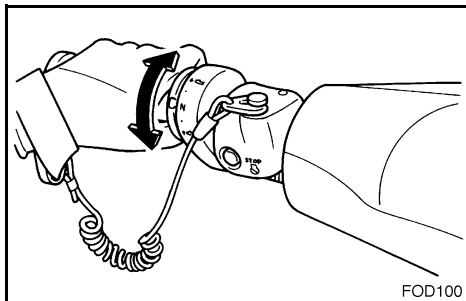
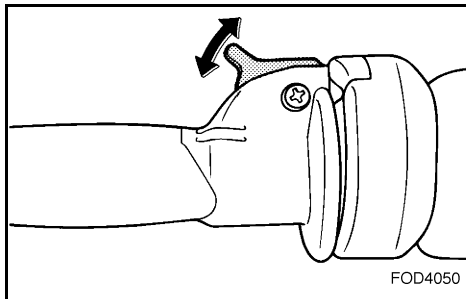



EJU01106

## Cleaning and adjusting the spark plugs

The spark plug is an important engine component and is easy to inspect. The condition of the spark plug can indicate something about the condition of the engine. For example, if the center electrode porcelain is very white, this could indicate an intake air leak or carburetion problem in that cylinder. Do not attempt to diagnose any problems yourself. Have a Yamaha dealer service the watercraft.

Remove and inspect the spark plug periodically; heat and deposits will cause the spark plug to slowly break down and erode. If electrode erosion becomes excessive, or if carbon and other deposits are excessive, replace the spark plug with the specified plug.

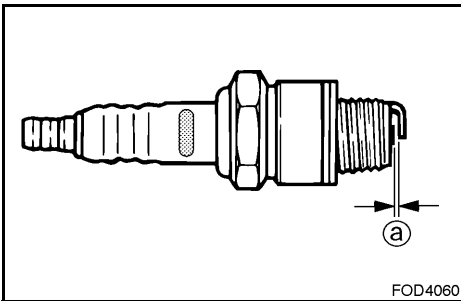

Standard spark plug: BR8ES-11

Measure the spark plug gap  $\textcircled{a}$  with a wire thickness gauge before installing the spark plug. Adjust the gap to specification if necessary.

Spark plug gap:  
1.0–1.1 mm (0.039–0.043 in)

### To reinstall spark plug:

1. Clean the gasket surface.
2. Wipe any dirt from the threads of the spark plug.
3. Screw the spark plug to the correct torque.

Spark plug torque:  
25 N·m (2.5 kgf·m, 18 ft·lb)

**NOTE:**

- Wipe off any water on the spark plug or inside the cap before installing the spark plug cap. Push the spark plug cap down until it clicks.
- If a torque wrench is not available when you are fitting a new spark plug, a good estimate of the correct torque is 1/4 turn to 1/2 turn past finger tight. Have the spark plug adjusted to the correct torque with a torque wrench as soon as possible.

**⚠WARNING**

**Be careful not to damage the insulator when removing or installing a spark plug. A damaged insulator could allow sparks to escape, which could lead to explosion or fire.**

EJU01339

**Lubrication points**

To keep moving parts sliding or rotating smoothly, coat them with water-resistant grease.

Recommended water-resistant grease:  
Yamaha Marine Grease/  
Yamaha Grease A

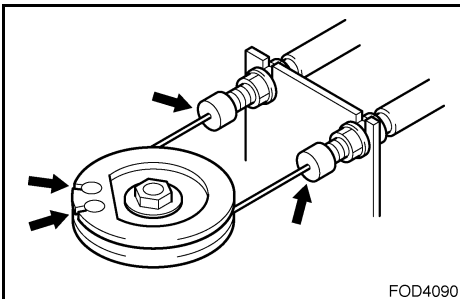

- Throttle cable (carburetor end)
- Oil pump cable

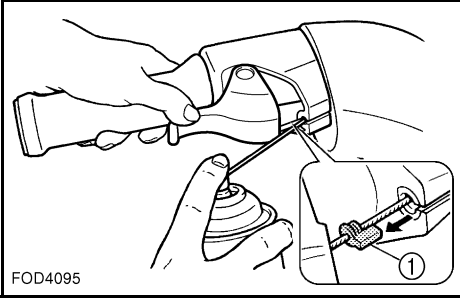

FOD4095

- Throttle cable (handlebar end)  
Squeeze the throttle lever and remove the seal ①. Spray a rust inhibitor into the outer cable. Refit the seal securely.

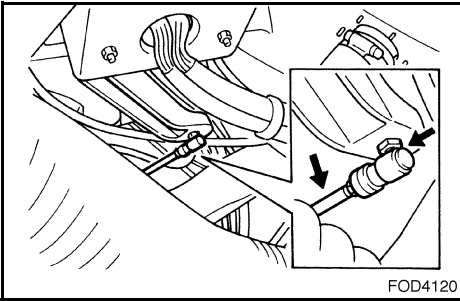

FOD4120

- Steering cable (handlebar end)

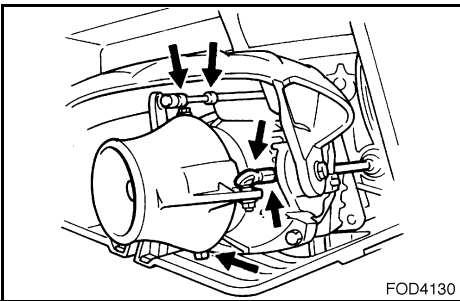

FOD4130

- Steering cable (nozzle end)
- Nozzle pivot shaft
- QSTS cable (nozzle end)

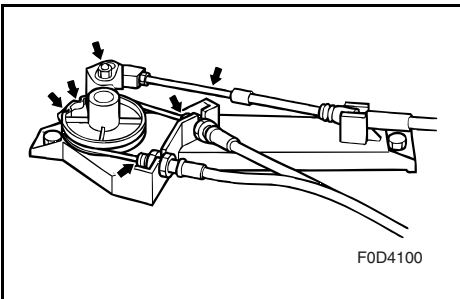

FOD4100

- QSTS cables (pulley end)

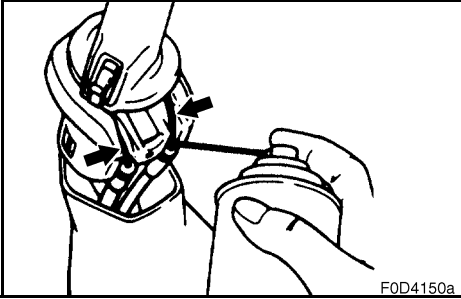

- QSTS cables (handlebar end)  
Remove the QSTS cable housing. Spray a rust inhibitor into the outer cable. Reinstall the QSTS cable housing.

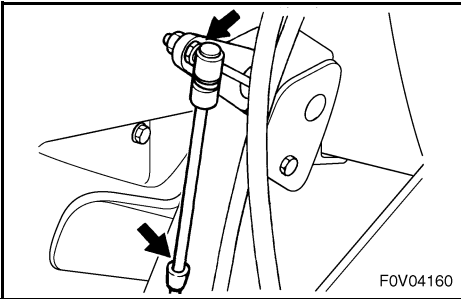

- Shift cable (lever end)

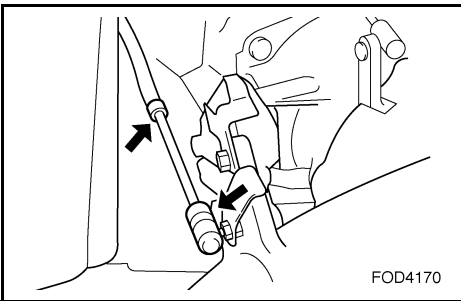

- Shift cable (reverse gate end)

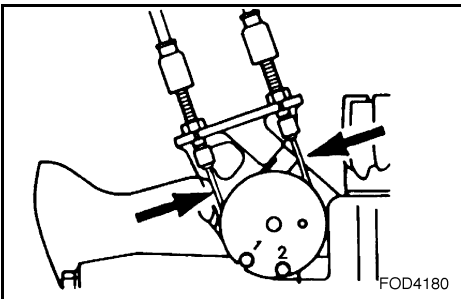

- YPVS cable

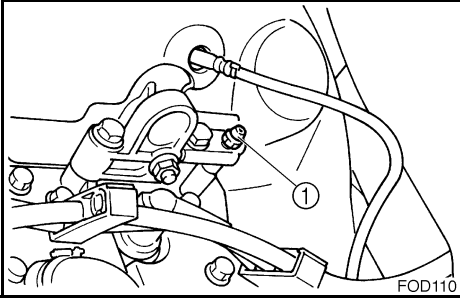

- Intermediate housing

Using a grease gun, fill the intermediate housing with water-resistant grease through the grease nipple ①.

Grease capacity:

Initial 10 hours or 1 month:

33.0–35.0 cm<sup>3</sup> (1.11–1.18 oz)

Every 100 hours or 6 months:

6.0–8.0 cm<sup>3</sup> (0.20–0.27 oz)

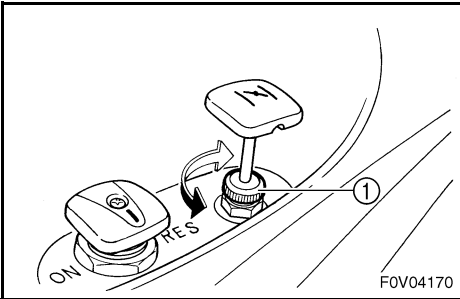

EJU01261

## Adjusting the choke cable

Check that the choke cable is properly adjusted.

1. Pull the choke knob out until it stops, and then release the knob. The knob should not move.
2. If the choke knob moves back on its own, tighten the choke knob adjusting nut ① slightly. If the knob is difficult to move, loosen the adjusting nut slightly.





EJU01108

## Inspecting the battery

Check the level of the battery electrolyte and make sure the leads are secure.

### **⚠WARNING**

**Battery electrolyte is poisonous and dangerous, causing severe burns, etc. Electrolyte contains sulfuric acid. Avoid contact with skin, eyes or clothing.**

#### **Antidotes**

**External: Flush with water.**

**Internal: Drink large quantities of water or milk. Follow with milk of magnesia, beaten egg or vegetable oil. Call physician immediately.**

**Eyes: Flush with water for 15 minutes and get prompt medical attention.**

**Batteries produce explosive gases. Keep sparks, flame, cigarettes, etc., well away. If using or charging the battery in an enclosed space, make sure that it is well ventilated. Always shield your eyes when working near batteries.**

**KEEP OUT OF THE REACH OF CHILDREN.**

### **CAUTION:**

**Be careful not to place the battery on its side.**

**Make sure to remove the battery from the battery compartment when adding battery electrolyte or charging the battery.**

**When checking the battery, make sure the breather hose is connected to the battery and not obstructed.**

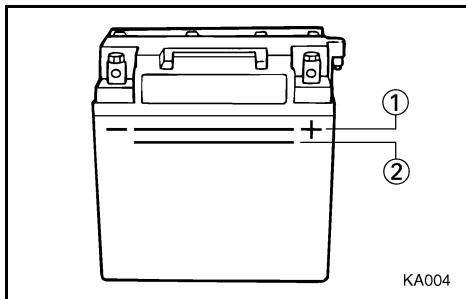
**To replenish the battery:**

1. Make sure that the electrolyte level is between the upper ① and lower ② level marks.
2. Refill the battery with distilled water if necessary.

**CAUTION:**

**Normal tap water contains minerals that are harmful to a battery. Use only distilled water for replenishing the battery.**

**To recharge the battery:****CAUTION:**

**Do not attempt to charge a battery hastily. Battery life may be shorter.**

Yamaha recommend charging battery by a Yamaha dealer or a battery dealer. If you charge the battery yourself, read the battery charger instructions carefully before charging and follow the points below.

1. Remove all caps from the battery cell.
2. Add distilled water to the specified level if the electrolyte level is low.
3. Set the charging rate to 1.9 ampere and charge the battery slowly until the explosive gases become coming out vigorously from battery cells.

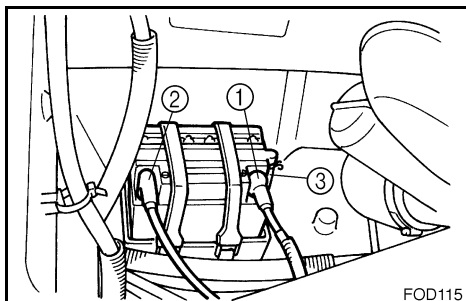
**To connect the battery terminals:**

1. Make sure that the connections are correct when you insert the battery in the watercraft.
2. Make sure that the breather hose is properly connected and that it is not damaged or obstructed.
3. Make sure that the battery is securely held in place.

- ① Positive (+): Red lead
- ② Negative (-): Black lead
- ③ Breather hose



EJU01109

## Adjusting the carburetor

The carburetor is a vital part of the engine and requires very sophisticated adjustment. Most adjusting should be left to a Yamaha dealer who has the professional knowledge and experience to perform it. However, the operator may adjust the trolling speed as part of the usual maintenance routine.

### CAUTION:

**The carburetor was set at the Yamaha factory after many tests. If the settings are disturbed by someone who does not have the necessary technical knowledge, poor engine performance and damage may result.**

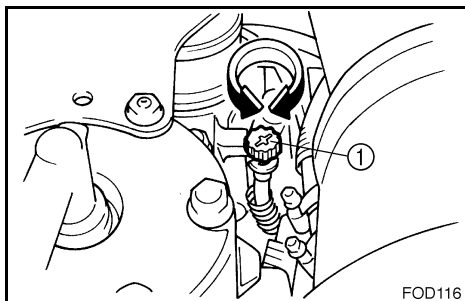

EJU01345

## Adjusting the trolling speed

1. Put the watercraft in the water.
2. Start the engine and warm it up for 1 or 2 minutes. Using a diagnostic tachometer or, if necessary, the tachometer in the multifunction meter, adjust the engine speed to specification.
3. Turn the throttle stop screw ① clockwise to increase engine speed if necessary. Turn it counterclockwise to decrease engine speed if necessary.

Trolling speed: 1,300–1,400 r/min

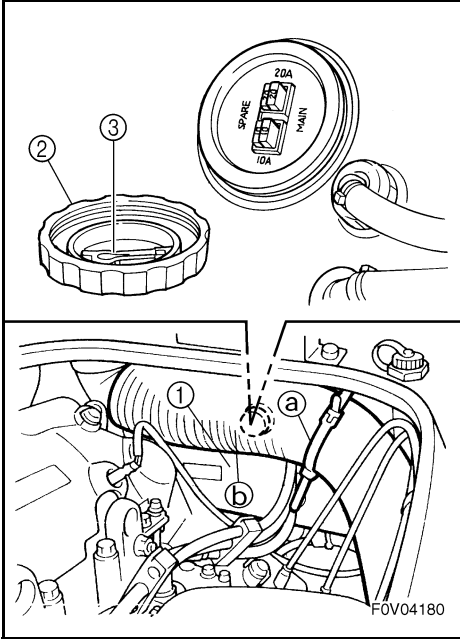

EJU01702

## Replacing the fuse

The fuses are in the electrical box ①.

### To replace the fuse:

1. Remove the hose band ③ and keep the duct hose ② away from the electrical box.
2. Remove the cap ② on the electrical box.
3. Remove the fuse using the fuse puller ③.
4. Replace the fuse with one of the correct amperage.

Fuse amperage: 10 A, 20 A

### **⚠WARNING**

**Do not use fuses of higher amperage that those recommended. Substitution of a fuse of improper rating can cause extensive electrical system damage and possible fire.**

EJU01112

## Bleeding the oil injection pump

If the oil tank becomes completely empty, or any hose connected to the oil pump has been disconnected, the oil pump must be bled to ensure proper oil flow.

If bleeding of the oil pump is necessary, have a Yamaha dealer bleed it.



EJU01365

## Specifications

<b>ITEM</b>	<b>MODEL</b>	<b>Unit</b>	<b>XLT1200</b>
<b>WATERCRAFT CAPACITY</b>			
Maximum people on board		Number of people	3
Maximum load capacity		kg (lb)	240 (530)
<b>DIMENSIONS</b>			
Length		mm (in)	3,160 (125)
Width		mm (in)	1,220 (48)
Height		mm (in)	1,130 (45)
Dry weight		kg (lb)	361 (796)
<b>PERFORMANCE</b>			
Maximum output		kW (PS) @ r/min	114 (155) @ 7,000
Maximum fuel consumption		L/h (US gal/h, Imp gal/h)	64 (17, 14)
Cruising range at full throttle		hr.	1.09
Trolling speed		r/min	1,300–1,400
<b>ENGINE</b>			
Engine type			2-stroke
Number of cylinders			3
Engine displacement		cm <sup>3</sup> (cu in)	1,176 (71.8)
Bore & stroke		mm (in)	80.0 × 78.0 (3.15 × 3.07)
Compression ratio			5.9:1
Lubrication system			Variable oil injection
Cooling system			Water cooled
Starting system			Electric starter
Ignition system			Digital CDI
Spark plug			BR8ES-11 (NGK)
Spark plug gap		mm (in)	1.0–1.1 (0.039–0.043)
Battery capacity		V-AH	12-19
Charging system			Flywheel magneto
<b>DRIVE UNIT</b>			
Propulsion system			Jet pump
Jet pump type			Axial flow, single stage
Impeller rotation			Counterclockwise (viewed from rear)
Transmission			Direct drive from engine
Jet thrust nozzle horizontal angle		Degree	24 + 24
Jet thrust nozzle trim angle		Degree	-7, -2, 3, 8, 13
<b>FUEL AND OIL</b>			
Recommended fuel			Regular unleaded gasoline
Minimum octane rating		PON	86
		RON	90
Recommended engine oil			YAMALUBE 2-W or an equivalent NMMA-certified TC-W3 marine oil
Fuel tank capacity			
Total		L (US gal, Imp gal)	70 (18.5, 15.5)
Reserve		L (US gal, Imp gal)	12 (3.2, 2.7)
Oil tank capacity		L (US gal, Imp gal)	5.5 (1.5, 1.3)



---

**-MEMO-**

EJU01115

# TROUBLESHOOTING AND EMERGENCY PROCEDURES

<b>Troubleshooting</b> .....	5-1
Troubleshooting chart .....	5-1
<b>Emergency procedures</b> .....	5-4
Cleaning the jet intake and impeller .....	5-4
Jumping the battery .....	5-5
Towing the watercraft .....	5-7
Submerged watercraft .....	5-8





EJU01116

# Troubleshooting

If you have any trouble with your watercraft, use this section to check for the possible cause.

If you cannot find the cause, or if the procedure for replacement or repair is not described in this Owner's/Operator's Manual, have a Yamaha dealer perform the necessary service.

EJU01373

## Troubleshooting chart

TROUBLE	POSSIBLE CAUSE	REMEDY	PAGE	
<b>Engine does not start</b>	<b>Starter motor does not turn over</b>			
	Multifunction meter	"LOCK" mode selected	Select "START" mode	2-21
	Engine shut-off switch	Clip not in place	Install clip	2-10
	Fuse	Burned out	Replace the fuse and check wiring	4-23
	Battery	Run down	Recharge	4-20
		Poor terminal connections	Tighten as required	4-20
		Terminal corroded	Clean	4-5
	Starter motor	Faulty	Have serviced by Yamaha dealer	—
	<b>Starter motor turns over</b>			
	Fuel cock	Turned to "OFF"	Turn the fuel cock to "ON"	2-9
	Fuel	Empty	Refill as soon as possible	3-3
		Stale or contaminated	Have serviced by Yamaha dealer	4-10
	Fuel tank	Water or dirt present	Have serviced by Yamaha dealer	4-11
	Spark plug	Fouled or defective	Clean or replace	4-15
	Spark plug cap	Not connected or loose	Connect properly	4-15
	Crankcase	Filled with water	Crank engine with plug out until clean	5-8
	Fuel filter	Clogged or water pooled	Have serviced by Yamaha dealer	4-11
	Choke	Knob moves back on its own	Tighten the choke knob adjusting nut	4-19
Water temperature sensor	Failed	Have serviced by Yamaha dealer	—	





TROUBLE	POSSIBLE CAUSE		REMEDY	PAGE
<b>Engine runs irregularly or stalls</b>	Fuel	Empty	Refill as soon as possible	3-3
		Stale or contaminated	Have serviced by Yamaha dealer	4-10
	Choke	Knob pulled	Push fully in	2-10
	Fuel filter	Clogged or water pooled	Have serviced by Yamaha dealer	4-11
	Fuel tank	Water or dirt present	Have serviced by Yamaha dealer	4-11
	Spark plug	Fouled or defective	Replace	4-15
		Incorrect heat range	Replace	4-15
		Gap incorrect	Adjust	4-15
	Spark plug cap	Loose	Connect properly	4-15
		Cracked, torn, or damaged	Replace	—
	Electrical wiring	Loose connection	Tighten or connect properly	—
	Carburetor	Incorrect idle adjustment	Adjust idle	4-22
		Clogged	Have serviced by Yamaha dealer	—
<b>Warning light or indicator blinks</b>	Fuel level	Empty	Refill as soon as possible	3-3
	Engine oil level	Empty	Refill immediately	3-4
		Oil filter clogged	Clean	4-12
	Engine overheated	Jet intake clogged	Clean	5-4
		Water temperature sensor failed	Have serviced by Yamaha dealer	—
	Low battery voltage	Battery voltage low	Charge	4-20
		Battery terminal connected wrong	Connect properly	4-20



TROUBLE	POSSIBLE CAUSE		REMEDY	PAGE
<b>Watercraft slow or loses power</b>	Cavitation	Jet intake clogged	Clean	5-4
		Impeller damaged or worn	Have serviced by Yamaha dealer	—
	Engine over-heated	Jet intake clogged	Clean	5-4
	Fuel filter	Clogged	Have serviced by Yamaha dealer	4-11
	Spark plug	Fouled or defective	Replace	4-15
		Incorrect heat range	Replace	4-15
		Gap incorrect	Adjust	4-15
	Spark plug caps	Loose	Connect properly	4-15
	Electrical wiring	Loose connection	Tighten or connect properly	—
	Fuel	Stale or contaminated	Have serviced by Yamaha dealer	4-10
Bilge	Water in bilge	Drain	3-7	

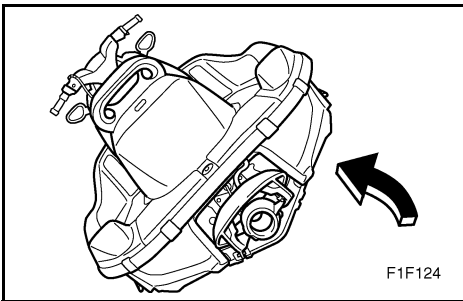
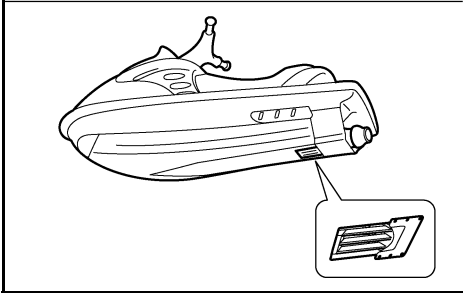
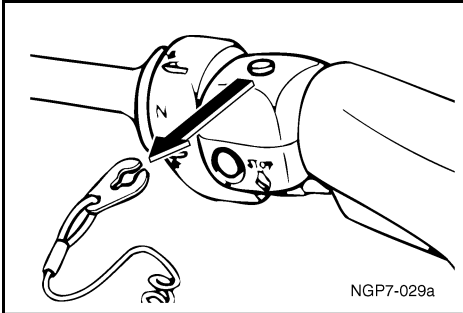

EJU01118

## Emergency procedures

EJU01119

### Cleaning the jet intake and impeller

If weeds or debris get caught in the intake or impeller, cavitation can occur, causing jet thrust to decrease even though engine speed rises. If this condition is allowed to continue, the engine will overheat and may seize. If there is any sign that the jet intake or impeller is clogged with weeds or debris, beach the watercraft and check the intake and impeller. Always stop the engine before beaching the watercraft.

#### **⚠WARNING**

Before attempting to remove weeds or debris from the jet intake or impeller areas, shut the engine off and remove the clip from the engine shut-off switch. Severe injury or death could result from contact with the rotating parts of the jet pump.

1. Turn the watercraft on its side as shown.

#### **CAUTION:**

- Place a suitable clean cloth or carpeting underneath the watercraft to protect it from abrasions and scratches.
- Always turn the watercraft over onto its port (left) side.
- When turning the watercraft on its side, support the bow so the handlebars cannot be bent or damaged.



2. Remove any weeds or debris from around the drive shaft, impeller, pump housing, and jet thrust nozzle.  
If debris is difficult to remove, consult your Yamaha dealer.

**CAUTION:**

**Always avoid operating your watercraft in areas where weed growth is thick. If traveling in weeded areas is unavoidable, operate the engine alternately at partial throttle and full throttle. Weeds tend to accumulate more at a steady speed and at trolling speed. If weeds clog the intake or impeller area and cause cavitation, follow the cleaning procedure above.**

EJU01120

## Jumping the battery

If the watercraft battery has run down, the engine can be started using a 12-volt battery and jumper cables.

**⚠WARNING**

**Battery electrolyte is poisonous and dangerous, causing severe burns, etc. Electrolyte contains sulfuric acid. Avoid contact with skin, eyes or clothing.**

**Antidotes**

**External: Flush with water.**

**Internal: Drink large quantities of water or milk. Follow with milk of magnesia, beaten egg or vegetable oil. Call physician immediately.**

**Eyes: Flush with water for 15 minutes and get prompt medical attention.**

**Batteries give off explosive gases. Keep sparks, flame, cigarettes, etc. well away. If using or charging the battery in an enclosed area, make sure that it is well ventilated. Always shield your eyes when working near batteries.**

**KEEP OUT OF THE REACH OF CHILDREN.**

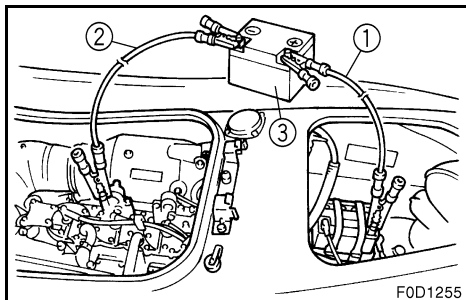

EJU01121

### Connecting the jumper cables

1. Connect the positive (+) jumper cable ① to the positive (+) terminals of both batteries.
2. Connect one end of the negative (-) jumper cable ② to the negative (-) terminal of the booster battery ③.
3. Connect the other end of the negative (-) cable to an unpainted bolt on the cylinder head.

**CAUTION:** \_\_\_\_\_

Do not connect the end of the jumper cable to the negative (-) terminal on the watercraft battery! Be sure all connections are secure and correct before attempting to start the engine. Any wrong connection may damage the electrical system.

4. Start the engine, and then disconnect the cables by reversing the steps above.

**CAUTION:** \_\_\_\_\_

- Never push the start switch while the engine is running.
- Do not operate the start switch for more than 5 seconds, otherwise the battery will be discharged and the engine will not start. Also, the starter motor may be damaged. If the engine does not start in 5 seconds, release the start switch, wait 15 seconds, and try again.



EJU01122

## Towing the watercraft

If the watercraft becomes inoperative in the water, it can be towed to shore.

If the watercraft must be towed in an emergency using a tow line, the operator should ride the watercraft, holding onto the handlebars.

### CAUTION:

- Tow the watercraft slowly; water may enter the air intake and flood the engine compartment if the watercraft is towed too fast.
- Tow the watercraft using the bow eye ① only.
- The bow must be kept up out of the water during towing to prevent water from entering the engine compartment.

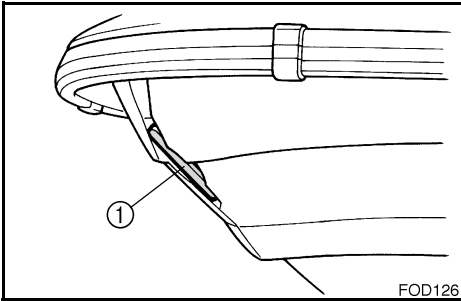

### WARNING

- The watercraft should only be towed in an emergency.
- The tow line should be long enough so that the watercraft will not collide with the towing boat when slowing down. A good rule of thumb is a tow line which is three times the combined length of the towing boat and the watercraft. A shorter length of rope can be used if the watercraft is towed very slowly.
- The operator of the towing boat must keep speed to a minimum and avoid traffic or obstacles which could be a hazard to the rider on the watercraft.



EJU01123

## Submerged watercraft

If the watercraft is submerged or flooded with water, follow the procedure below and consult a Yamaha dealer as soon as possible. Failure to do so may result in serious engine damage!

1. Beach the watercraft and remove the stern drain plugs to drain the water from the engine compartment.
2. Turn the fuel cock knob to "OFF."
3. Remove the spark plugs and dry them with a cloth.
4. Without reinstalling the spark plugs, crank the engine until all the water in the cylinders has been drained.
5. Install the stern drain plugs and the spark plugs.
6. Turn the fuel cock to "ON."
7. Launch the watercraft into the water, and then run the engine for at least 10 minutes. If the engine will not start, repeat steps above.
8. Turn the engine off. Turn the fuel cock to "OFF."
9. Have the watercraft inspected by a Yamaha dealer as soon as possible.



-MEMO-



EJU01124

# APPENDIX

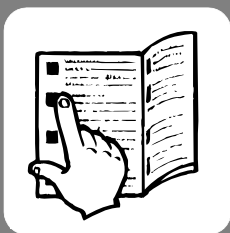

Index .....6-1



# Index

2-stroke engine oil ..... 3-2

## A

Adjusting the carburetor ..... 4-22

Adjusting the choke cable ..... 4-19

Adjusting the trolling speed ..... 4-22

## B

Battery ..... 3-8, 4-5

Battery warning indicator ..... 2-28

Beaching the watercraft ..... 3-31

Bilge ..... 3-7

Bleeding the oil injection pump ..... 4-23

Boarding alone ..... 3-24

Boarding and starting in deep water ..... 3-24

Boarding with passengers ..... 3-25

Bow down ..... 2-16

Bow up ..... 2-16

## C

Capsized watercraft ..... 3-26

Caution labels ..... 1-6

Choke knob ..... 2-10

Cleaning and adjusting the spark plugs ..... 4-15

Cleaning the jet intake and impeller ..... 5-4

Cleaning the watercraft ..... 4-6

Clock ..... 2-24

Connecting the jumper cables ..... 5-6

Cooling water pilot outlet ..... 2-12, 3-13

Cruising limitations ..... 1-10

## D

Docking the watercraft ..... 3-31

## E

Emergency procedures ..... 5-4

Engine break-in ..... 3-14

Engine compartment ..... 3-6

Engine oil meter ..... 2-24

Engine overheat warning indicator ..... 2-27

Engine overheat warning system ..... 2-17

Engine serial number ..... 1-1

Engine shut-off cord (lanyard) ..... 3-12

Engine shut-off switch ..... 2-10

Engine stop switch ..... 2-10

Enjoy your watercraft responsibly ..... 1-17

## F

Filling the fuel tank ..... 3-3

Filling the oil tank ..... 3-4

Fire extinguisher ..... 3-9

Flushing the cooling system ..... 4-1

Front seat ..... 2-6

Front storage compartment ..... 2-29

Fuel and oil ..... 3-1

Fuel and oil systems ..... 3-6

Fuel cock knob ..... 2-9

Fuel filter ..... 4-11

Fuel meter ..... 2-23

Fuel system ..... 4-4

Fuel tank ..... 4-11

Fuel tank filler cap ..... 2-8

Fuel warning indicator ..... 2-26

## G

Gasohol ..... 3-2

Gasoline ..... 3-1

Getting to know your watercraft ..... 3-20

Glove compartment ..... 2-30

## H

Handgrip ..... 2-16

Hazard information ..... 1-14

Hood ..... 2-7

Hour meter ..... 2-25

Hull Identification Number (HIN) ..... 1-1

## I

Identification numbers ..... 1-1

Important labels ..... 1-2

Inspecting and adjusting the throttle cable ..... 4-13

Inspecting the battery ..... 4-20

Inspecting the fuel system ..... 4-10

Inspecting the oil injection system ..... 4-12

Inspecting the QSTS mechanism ..... 4-14

Inspecting the shift cable ..... 4-13

Inspecting the steering cable ..... 4-13

## J

Jet unit ..... 3-12

Jumping the battery ..... 5-5



<b>L</b>			
Label location .....	1-2	Reverse on waterways .....	3-32
Launching the watercraft .....	3-16	Riding watercraft with passengers .....	3-21
Learning to operate your watercraft .....	3-20	Rough water operation .....	3-32
Leaving the watercraft .....	3-19	<b>S</b>	
Limitations on who may operate the watercraft .....	1-9	Safe boating rules .....	1-17
Location of main components .....	2-1	Safety information .....	1-9
Lubrication .....	4-3	Seat storage compartment .....	2-30
Lubrication points .....	4-16	Selecting "PADLOC" mode .....	2-21
<b>M</b>		Shift lever .....	2-14
Maintenance and adjustments .....	4-7	Shift lever and reverse gate .....	3-11
Multifunction meter .....	2-19, 3-13	Specifications .....	4-24
<b>O</b>		Speedometer .....	2-23
Oil filter .....	4-12	Starting and boarding in shallow water .....	3-23
Oil tank .....	4-12	Starting from a dock .....	3-23
Oil tank filler cap .....	2-8	Starting the engine .....	3-16
Oil warning indicator .....	2-27	Starting the watercraft .....	3-22
Operating your watercraft .....	3-20	Start switch .....	2-11
Operation .....	3-14	Steering system .....	2-12, 3-10
Operation of controls and other functions .....	2-5	Stopping the engine .....	3-19
Operation requirements .....	1-11	Stopping the watercraft .....	3-30
Other labels .....	1-7	Storage .....	4-1
Owner's/Operator's Manual and tool kit .....	4-8	Storage compartments .....	2-29
<b>P</b>		Submerged watercraft .....	5-8
PADLOC initial setting .....	2-20	Switches .....	3-13
PADLOC (Programmable digital locking ignition) .....	2-20	<b>T</b>	
Periodic maintenance chart .....	4-9	Tachometer .....	2-22
Post-operation checks .....	3-33	Throttle .....	3-10
Pre-operation check list .....	3-5	Throttle lever .....	2-11
Pre-operation check points .....	3-6	Tilt lever .....	2-13
Pre-operation checks .....	3-5	Towing the watercraft .....	5-7
Primary Identification (PRI-ID) number ...	1-1	Transporting .....	3-35
<b>Q</b>		Tripmeter .....	2-26
Quick Shift Trim System (QSTS) selector .....	2-15	Trip timer .....	2-25
<b>R</b>		Troubleshooting .....	5-1
Rear seat .....	2-5	Troubleshooting chart .....	5-1
Recommended equipment .....	1-13	Turning the watercraft .....	3-28
Replacing the fuse .....	4-23	<b>W</b>	
		Warning labels .....	1-3
		Watercraft characteristics .....	1-14
		Water separator .....	3-7
		Water-skiing .....	1-15







Printed in USA  
September 2001—0.8 × 1 CR  
**F0V-F8199-71**  
(XA1200A-A)  
(E)

Printed on recycled paper