



OWNER'S MANUAL  
MANUEL DU PROPRIÉTAIRE  
MANUAL DEL PROPIETARIO

**GRIZZLY**

**350**

**YFM35FGDW**

4S2-F8199-60



PRINTED IN USA  
2006.10-0.3x2 CR  
(E,F,S)



**OWNER'S MANUAL**

**GRIZZLY**

**350**

**YFM35FGDW**

**4S2-F8199-60-E0**

## EC Declaration of Conformity

conforming to Directive 98/37/EC

We YAMAHA MOTOR CO., LTD  
(Name of supplier)

2500 Shingai, Iwata, Shizuoka, Japan

Representing YAMAHA MOTOR MANUFACTURING CORPORATION  
of AMERICA Newnan, Georgia U.S.A.  
declare in sole responsibility, that the product

YFM350AS(5Y4AH14W060500101~)  
YFM350FWAN(5Y4AH15W060500101~)  
(Make, model)

to which this declaration applies, conforms to the essential  
health and safety requirements of Directive 98/37/EC,  
(If applicable)  
and to the other relevant Directives of EEC

89/336/EEC  
(Title and/or number and date of issue of the other Directives of EEC)

(If applicable)  
To effect correct application of the essential health and safety  
requirements stated in the Directives of EEC, the following  
standards and/or technical specifications were consulted:

EN292, ANSI/SVIA-1-2001  
(Title and/or number and date of issue of standards and/or specifications)

2500 Shingai Iwata, Japan MARCH, 2006  
(Place and date of issue)

General Manager   
Takaharu Ishima  
RV Engineering Division RV Company  
(Name and job function of authorized person)

# INTRODUCTION

Congratulations on your purchase of the Yamaha YFM35FGDW. This ATV represents the result of many years of Yamaha experience in the production of fine sporting, touring, and pacesetting racing machines. With the purchase of this Yamaha, you can now appreciate the high degree of craftsmanship and reliability that have made Yamaha a leader in these fields.

This manual will provide you with a good basic understanding of the features and operation of this ATV. **This manual includes important safety information. It provides information about special techniques and skills necessary to ride the ATV.** It also includes basic maintenance and inspection procedures. If you have any questions regarding the operation or maintenance of your ATV, please consult a Yamaha dealer.



## **AN IMPORTANT SAFETY MESSAGE:**

- READ THIS MANUAL COMPLETELY BEFORE OPERATING YOUR ATV. MAKE SURE YOU UNDERSTAND ALL INSTRUCTIONS.
- PAY CLOSE ATTENTION TO THE WARNING AND CAUTION LABELS ON THE ATV.
- THIS ATV, AND ANY OTHER ATV OVER 90 cc, SHOULD NOT BE RIDDEN BY ANYONE UNDER 16 YEARS OF AGE.

## IMPORTANT MANUAL INFORMATION

FAILURE TO FOLLOW THE WARNINGS CONTAINED IN THIS MANUAL CAN RESULT IN SERIOUS INJURY OR DEATH.

Particularly important information is distinguished in this manual by the following notations:

	<b>The Safety Alert Symbol means ATTENTION! BECOME ALERT! YOUR SAFETY IS INVOLVED!</b>
	<b>Failure to follow WARNING instructions <u>could result in severe injury or death</u> to the ATV operator, a bystander, or a person inspecting or repairing the ATV.</b>
<b>CAUTION:</b>	<b>A CAUTION indicates special precautions that must be taken to avoid damage to the ATV.</b>
<b>NOTE:</b>	A NOTE provides key information to make procedures easier or clearer.

\* Product and specifications are subject to change without notice.

EBU17350

## IMPORTANT NOTICE

EBU17370

Welcome to the Yamaha world of motor sports!

This ATV is designed and manufactured for use on UNPAVED surfaces only. It is unsafe to operate this ATV on any paved surface, paved street, paved road or motorway.

Please check your local riding laws and regulations before operating this ATV.

EBU17410

**YFM35FGDW  
OWNER'S MANUAL  
©2006 by Yamaha Motor Co., Ltd.  
1st edition, September 2006  
All rights reserved.  
Any reprinting or unauthorized use  
without the written permission of  
Yamaha Motor Co., Ltd.  
is expressly prohibited.  
Printed in U.S.A.**

# TABLE OF CONTENTS

SAFETY INFORMATION .....	1-1	Fuel .....	4-14
LOCATION OF THE WARNING AND SPECIFICATION LABELS .....	2-1	Fuel cock .....	4-15
DESCRIPTION .....	3-1	Starter (choke) .....	4-16
Left view .....	3-1	Seat .....	4-17
Right view .....	3-1	Storage compartment .....	4-18
Controls and instruments .....	3-2	Front carrier .....	4-19
INSTRUMENT AND CONTROL FUNCTIONS .....	4-1	Rear carrier .....	4-19
Main switch .....	4-1	Adjusting the front and rear shock absorber assemblies .....	4-19
Indicator lights and warning light .....	4-2	PRE-OPERATION CHECKS .....	5-1
Speedometer .....	4-3	Pre-operation check list .....	5-1
Handlebar switches .....	4-4	Fuel .....	5-3
Throttle lever .....	4-9	Engine oil .....	5-3
Speed limiter .....	4-10	Final gear oil .....	5-3
Front brake lever .....	4-11	Differential gear oil .....	5-3
Brake pedal and rear brake lever .....	4-11	Front and rear brakes .....	5-3
Parking brake .....	4-12	Throttle lever .....	5-4
Drive select lever .....	4-12	Tires .....	5-4
Recoil starter .....	4-13	Measuring the tire pressure .....	5-5
Fuel tank cap .....	4-13	Tire wear limit .....	5-6
		Chassis fasteners .....	5-7
		Instruments, lights and switches .....	5-7



OPERATION .....	6-1
Starting a cold engine .....	6-1
Starting a warm engine .....	6-3
Operating the drive select lever and driving in reverse .....	6-3
Engine break-in .....	6-4
Parking .....	6-5
Parking on a slope .....	6-5
Accessories and loading .....	6-6
RIDING YOUR ATV .....	7-1
GETTING TO KNOW YOUR ATV.....	7-2
RIDE WITH CARE AND GOOD JUDGEMENT.....	7-2
BE CAREFUL WHERE YOU RIDE.....	7-9
TURNING YOUR ATV .....	7-13
CLIMBING UPHILL .....	7-14
RIDING DOWNHILL.....	7-17
CROSSING A SLOPE.....	7-18
CROSSING THROUGH SHALLOW WATER .....	7-19
RIDING OVER ROUGH TERRAIN .....	7-22
SLIDING AND SKIDDING.....	7-22
WHAT TO DO IF.....	7-24
WHAT TO DO.....	7-24

PERIODIC MAINTENANCE AND MINOR REPAIR .....	8-1
Owner's manual and tool kit .....	8-1
Periodic maintenance and lubrication chart .....	8-3
Removing and installing the panel .....	8-8
Checking the spark plug .....	8-8
Engine oil and oil filter cartridge .....	8-10
Final gear oil .....	8-14
Differential gear oil .....	8-17
Cleaning the air filter element .....	8-19
Cleaning the spark arrester .....	8-22
V-belt cooling duct check hose .....	8-24
V-belt case drain plug .....	8-24
Adjusting the carburetor .....	8-24
Adjusting the engine idling speed .....	8-25
Adjusting the throttle cable free play .....	8-26
Valve clearance .....	8-26
Adjusting the drive select lever safety system cable .....	8-27
Checking the front brake pads and rear brake friction plates .....	8-27
Checking the brake fluid level .....	8-28
Changing the brake fluid .....	8-29
Checking the front brake lever free play .....	8-29

Adjusting the brake pedal and rear brake lever free play and checking the brake pedal position .....	8-30
Axle boots .....	8-34
Brake light switches .....	8-35
Checking and lubricating the cables .....	8-36
Checking and lubricating the front and rear brake levers .....	8-36
Checking and lubricating the brake pedal .....	8-37
Checking the wheel bearings .....	8-37
Lubricating the drive shaft universal joint .....	8-37
Checking the stabilizer bushes .....	8-38
Lubricating the knuckle pivots .....	8-38
Lubricating the steering shaft .....	8-38
Battery .....	8-39
Replacing a fuse .....	8-40
Replacing a headlight bulb .....	8-42
Adjusting a headlight beam .....	8-44
Replacing the tail/brake light bulb .....	8-44
Removing a wheel .....	8-44
Installing a wheel .....	8-45
Troubleshooting .....	8-46
Troubleshooting chart .....	8-47

CLEANING AND STORAGE .....	9-1
Cleaning .....	9-1
Storage .....	9-2

SPECIFICATIONS .....	10-1
----------------------	------

CONSUMER INFORMATION.....	11-1
Identification numbers .....	11-1



## SAFETY INFORMATION

EBU17562

### **AN ATV IS NOT A TOY AND CAN BE HAZARDOUS TO OPERATE.**

An ATV handles differently from other vehicles, including motorcycles and cars. A collision or roll-over can occur quickly, even during routine maneuvers such as turning and riding on hills or over obstacles, if you fail to take proper precautions.

**SEVERE INJURY OR DEATH** can result if you do not follow these instructions:

- Read this manual and all labels carefully and follow the operating procedures described.
- Never operate an ATV without proper training or instruction.
- Always follow the age recommendation:
  - A child under 16 years old should never operate an ATV with engine size greater than 90 cc.
- Never allow a child under age 16 to operate an ATV without adult supervision, and never allow continued use of an ATV by a child if he or she does not have the abilities to operate it safely.

- Never carry a passenger on an ATV.
- Always avoid operating an ATV on any paved surfaces, including sidewalks, driveways, parking lots and paved streets.
- Never operate an ATV on any paved street, paved road or motorway.
- Watch carefully for other vehicles when operating on unpaved public streets or roads. Make sure you know your country's laws and regulations before you ride on unpaved public streets or roads.
- Never operate an ATV without wearing an approved motorcycle helmet that fits properly. You should also wear eye protection (goggles or face shield), gloves, boots, a long-sleeved shirt or a jacket, and long pants.
- Never consume alcohol or drugs before or while operating this ATV.
- Never operate at speeds too fast for your skills or the riding conditions. Always go at a speed that is proper for the terrain, visibility, operating conditions, and your experience.
- Never attempt wheelies, jumps, or other stunts.

- Always inspect your ATV each time you use it to make sure it is in safe operating condition. Always follow the inspection and maintenance procedures and schedules described in this manual.
- Always keep both hands on the handlebars and both feet on the footboards of the ATV during operation.
- Always go slowly and be extra careful when operating on unfamiliar terrain. Always be alert to changing terrain conditions when operating the ATV.
- Never operate on excessively rough, slippery or loose terrain until you have learned and practiced the skills necessary to control the ATV on such terrain. Always be especially cautious on these kinds of terrain.
- Always follow proper procedures for turning as described in this manual. Practice turning at low speeds before attempting to turn at faster speeds and never turn at excessive speeds.
- Never operate the ATV on hills too steep for the ATV or for your abilities. Practice on smaller hills before attempting larger hills.
- Always follow proper procedures for climbing hills as described in this manual. Check the terrain carefully before you start up any hill. Never climb hills with excessively slippery or loose surfaces. Shift your weight forward. Never open the throttle suddenly. Never go over the top of a hill at high speed.
- Always follow proper procedures for going down hills and for braking on hills as described in this manual. Check the terrain carefully before you start down any hill. Shift your weight backward. Never go down a hill at high speed. Avoid going down a hill at an angle that would cause the vehicle to lean sharply to one side. Go straight down the hill where possible.
- Always follow proper procedures for crossing the side of a hill as described in this manual. Avoid hills with excessively slippery or loose surfaces. Shift your weight to the uphill side of the ATV. Never attempt to turn the ATV around on any hill until you have mastered the turning technique described in this manual on level ground. Avoid crossing the side of a steep hill if possible.
- Always use proper procedures if you stall or roll backwards when climbing a hill. Maintain a steady speed when climbing a hill. If you stall or

roll backwards, follow the special procedure for braking described in this manual. Dismount on the uphill side or to a side if pointed straight uphill. Turn the ATV around and remount, following the procedure described in this manual.

- Always check for obstacles before operating in a new area.
- Never attempt to operate over large obstacles, such as large rocks or fallen trees. Always follow proper procedures when operating over obstacles as described in this manual.
- Always be careful when skidding or sliding. Learn to safely control skidding or sliding by practicing at low speeds and on level, smooth terrain. On extremely slippery surfaces, such as ice, go slowly and be very cautious in order to reduce the chance of skidding or sliding out of control.
- Never operate an ATV in fast flowing water or in water deeper than that recommended in this manual. Remember that wet brakes may have reduced stopping ability. Test your brakes after leaving water. If necessary, apply them several times to let friction dry out the linings.

- Always be sure there are no obstacles or people behind you when you operate in reverse. When it is safe to proceed in reverse, go slowly.
- Always use the size and type of tires specified in this manual.
- Always maintain proper tire pressure as described in this manual.
- Never modify an ATV through improper installation or use of accessories.
- Never exceed the stated load capacity for an ATV. Cargo should be properly distributed and securely attached. Reduce speed and follow instructions in this manual for carrying cargo or pulling a trailer. Allow greater distance for braking.

EWB00061



- **Always turn off the engine when refueling.**
- **Do not refuel right after the engine has been running and is still very hot.**
- **Do not spill gasoline on the engine or exhaust pipe/muffler when refueling. Never refuel while smoking, or in the vicinity of sparks, open flames, or other sources of ig-**

nition such as the pilot lights of water heaters and clothes dryers. Gasoline can catch fire and you could be burned.

- When transporting the ATV in another vehicle, be sure it is kept upright and that the fuel cock is in the “OFF” position. Otherwise, fuel may leak out of the carburetor or fuel tank.
- Gasoline is poisonous. If you should swallow some gasoline or inhale a lot of gasoline vapor, or get some gasoline in your eyes, seek medical help immediately. If gasoline spills on your skin, wash with soap and water. If gasoline spills on your clothing, change your clothes.

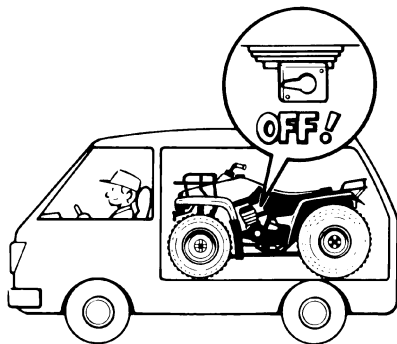

EWB00070

**! WARNING**

Always operate your ATV in an area with adequate ventilation. Never start or run the engine in a closed area. Exhaust fumes are poisonous and may cause loss of consciousness and death within a short time.

# LOCATION OF THE WARNING AND SPECIFICATION LABELS

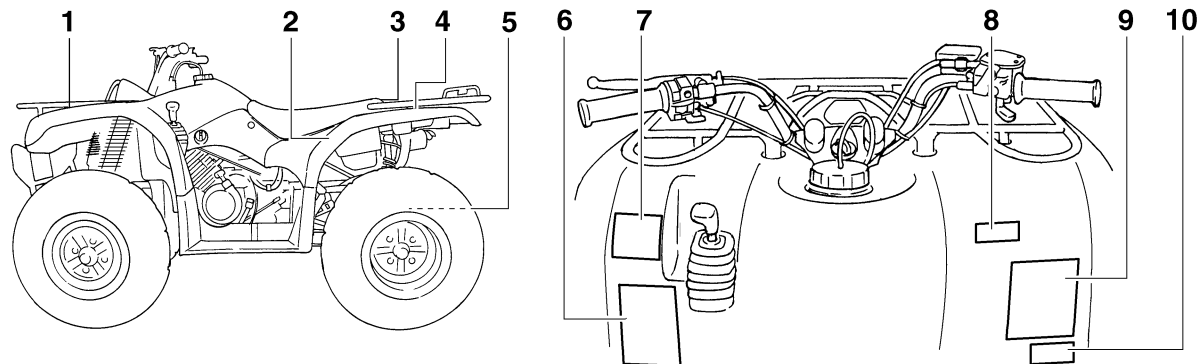

Read and understand all of the labels on your ATV. These labels contain important information for safe and proper operation.

2

Never remove any labels from your ATV. If a label becomes difficult to read or comes off, request a replacement label from your Yamaha dealer.

**For Europe and Oceania**

1

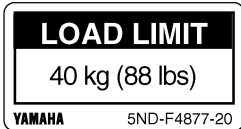

4

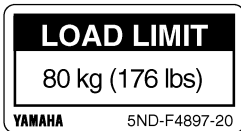

5

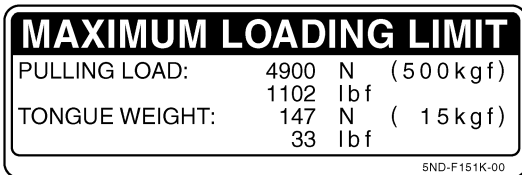

2

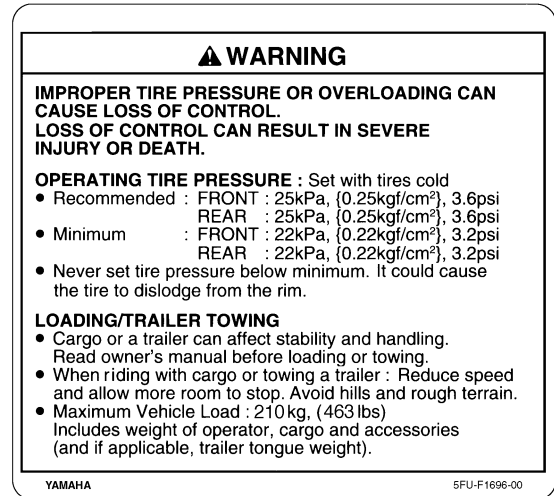



## For Europe

3



6

YAMAHA 4XE-F156B-50

**GB** Before you operate this vehicle, read the owner's manual.

**D** Lesen Sie die Bedienungsanleitung bevor Sie dieses Fahrzeug fahren.

**E** Antes de conducir este vehículo, lea el Manual del Propietario.

**F** Lire le manuel du propriétaire avant d'utiliser ce véhicule.

**I** Prima di usare il veicolo, leggete il manuale di istruzioni.

**NL** Voor het gebruik van dit voertuig de handleiding met aandacht lezen.

**P** Antes de utilizar este veículo, leia o manual do proprietário.

**S** Innan du kör detta fordon, läs handboken.

2

## For Europe

7



2

10

CE	YAMAHA MOTOR MFG. CORP.	MODEL	YFM350FWAN
	OF AMERICA	POWER	15.9 KW
	NEWNAN, GEORGIA U.S.A.	DRY WEIGHT	259.8 Kg
			4S2-F155A-00

9

**(GB)** Tuning the ATV in 4WD-LOCK ("DIFF. LOCK") takes more effort.  
Operate at a slow speed and allow extra time and distance for maneuvers to avoid loss of control.

**(D)** Wenden in der Stellung "4WD-LOCK" ("DIFF. LOCK") ist mühsamer.  
Reduzierte Geschwindigkeit sowie zusätzliche Manövrierzeit und -strecke bedeuten bessere Fahrzeugkontrolle.

**(E)** Girar el ATV con tracción a las 4 ruedas y bloqueo del diferencial ("DIFF. LOCK") cuesta más.  
Para evitar perder el control, circule a baja velocidad y prevea más tiempo y distancia para las maniobras.

**(F)** La prise de virages requiert plus d'efforts en traction 4WD-LOCK ("DIFF. LOCK")  
Toujours rouler lentement et se réserver plus de temps et d'espace pour les manoeuvres afin d'éviter de perdre le contrôle du véhicule.

**(I)** L'uso dello sterzo dell'ATV con la trazione 4WD-LOCK ("DIFF. LOCK") richiede uno sforzo maggiore.  
Guidare a bassa velocità e prevedere un tempo e una distanza maggiori per le manovre per evitare di perdere il controllo.

**(NL)** In 4WD-LOCK ("DIFF. LOCK") is meer kracht vereist om met de ATV een bocht te nemen.  
Rijd langzaam, neem de tijd bij het manoeuvreren en houd ruime afstand aan om uw controle over het voertuig te behouden.

**(P)** Rodar o ATV para 4WD-LOCK (<<DIFF. LOCK>>) requer mais esforço.  
Prossiga a baixa velocidade e deixe tempo e distância suficientes para efectuar manobras sem perder o controlo.

**(S)** Det krävs mer kraft för att vrida på ATV i Läget 4WD-LOCK ("DIFF. LOCK").  
Kör långsamt och sätt av mer tid och större avstånd för manövrar, för att inte riskera att tappa kontrollen.

3

**⚠ WARNING**

**NEVER ride as a passenger.**

Passengers can cause a loss of control, resulting in **SEVERE INJURY** or **DEATH**.



**YAMAHA**

6

**⚠ WARNING**

Improper ATV use can result in **SEVERE INJURY** or **DEATH**.



**ALWAYS USE AN APPROVED HELMET AND PROTECTIVE GEAR**

**NEVER USE ON PUBLIC ROADS**

**NEVER CARRY PASSENGERS**

**NEVER USE WITH DRUGS OR ALCOHOL**

**NEVER operate :**

- without proper training or instruction.
- at speeds too fast for your skills or the conditions.
- on public roads - a collision can occur with another vehicle.
- with a passenger - passengers affect balance and steering and increase risk of losing control.

**ALWAYS :**

- use proper riding techniques to avoid vehicle overturns on hills and rough terrain and in turns.
- avoid paved surfaces - pavement may seriously affect handling and control.

**LOCATE AND READ OWNER'S MANUAL. FOLLOW ALL INSTRUCTIONS AND WARNINGS.**

YAMAHA 4XE-F1568-10

For Oceania

7

2

**⚠ WARNING**



Operating this ATV if you are under the age of 16 increases your chance of severe injury or death.

**NEVER** operate this ATV if you are under age 16.

**YAMAHA** 4XE-F415A-00

8

**⚠ WARNING**

Turning the ATV in 4WD-LOCK("DIFF. LOCK") takes more effort.

Operate at a slow speed and allow extra time and distance for maneuvers to avoid loss of control.

5ND-F1558-00

## DESCRIPTION

EBU17690

### Left view

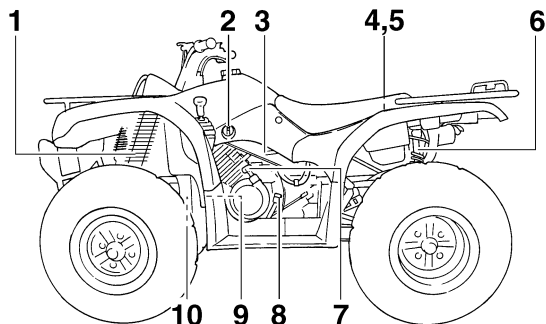

1. Front shock absorber assembly spring preload adjusting ring
2. Fuel cock
3. Throttle stop screw
4. Fuses
5. Battery
6. Rear shock absorber assembly spring preload adjusting ring
7. Recoil starter
8. Engine oil filler cap
9. Oil filter cartridge
10. V-belt cooling duct check hose

EBU17700

### Right view

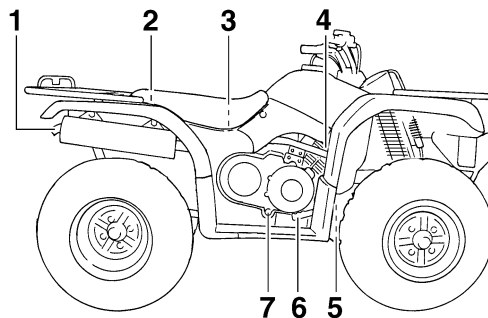

1. Spark arrester
2. Storage compartment and tool kit
3. Air filter case
4. Spark plug
5. Rear brake light switch
6. Brake pedal
7. V-belt case drain plug

## Controls and instruments

3

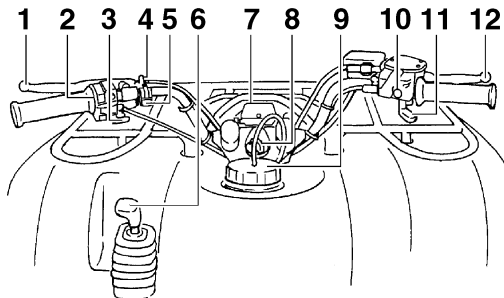

1. Rear brake lever
2. Handlebar switches
3. Starter (choke)
4. Parking brake lock plate
5. Horn switch
6. Drive select lever
7. Speedometer
8. Main switch
9. Fuel tank cap
10. On-Command four-wheel-drive/differential gear lock switch
11. Throttle lever
12. Front brake lever

**NOTE:** \_\_\_\_\_  
 The ATV you have purchased may differ slightly from the figures shown in this manual.  
 \_\_\_\_\_

# INSTRUMENT AND CONTROL FUNCTIONS

EBU17770

## Main switch

The positions of the main switch are as follows:

### ON

All electrical systems are supplied with power. The headlights, meter lighting and taillight come on when the light switch is on, and the engine can be started. The key cannot be removed.

### OFF

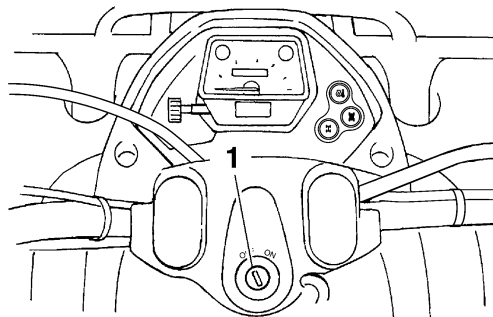

All electrical systems are off. The key can be removed.

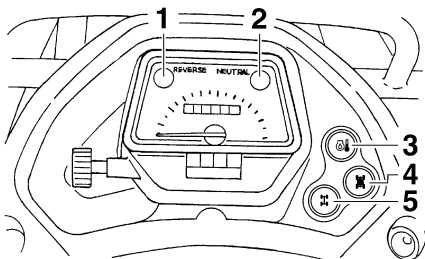

1. Main switch

## Indicator lights and warning light



1. Reverse indicator light “REVERSE”
2. Neutral indicator light “NEUTRAL”
3. Oil temperature warning light “”
4. On-Command differential gear lock indicator light “”
5. On-Command four-wheel-drive indicator light “”

EBU28331

### Reverse indicator light “REVERSE”

This indicator light comes on when the transmission is in the reverse position.

Furthermore, this indicator light flashes:

- when the override switch is being pushed,
- when the engine is being raced for 10 seconds or more.

### NOTE: \_\_\_\_\_

If the indicator light flashes under any other circumstances or the speedometer does not show the speed while riding, have a Yamaha dealer check the speed sensor circuit.

EBU17870

### Neutral indicator light “NEUTRAL”

This indicator light comes on when the transmission is in the neutral position.

EBU26931

### Oil temperature warning light “”

This warning light comes on when the engine overheats. When this occurs, stop the engine as soon as it is safe to do so, and allow it to cool.

The electrical circuit of the warning light can be checked by turning the key to “ON”, with the engine stop switch set to “○”, and then pushing the start switch.

If the warning light does not come on while the start switch is being pushed, then go off after the start switch is released, have a Yamaha dealer check the electrical circuit.



If the warning light stays on, allow the engine to cool. If the warning light stays on when the engine is cool, have a Yamaha dealer check the electrical circuit.

ECB00010

**CAUTION:**

- **The engine may overheat if the ATV is overloaded. In this case, reduce the load to specification.**
- **Start the engine after making sure that the warning light is out. Continuous use while the warning light is on may cause damage to the engine.**

EBU17952

**On-Command four-wheel-drive indicator light**



This indicator light comes on when the On-Command four-wheel-drive switch is set to the “4WD” position.

**NOTE:**

Due to the synchronizing mechanism in the differential gear case, the light may not come on until the ATV starts moving.

EBU28341

**On-Command differential gear lock indicator light**

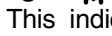

This indicator light and the On-Command four-wheel-drive indicator light “” come on when the On-Command differential gear lock switch is set to the “LOCK” position.

EBU18020

**Speedometer**

The speedometer shows the riding speed. This speedometer is equipped with an odometer and a tripmeter. The tripmeter can be reset to “0” with the reset knob. Use the tripmeter to estimate how far you can ride on a tank of fuel before going to reserve. This information will enable you to plan fuel stops in the future.

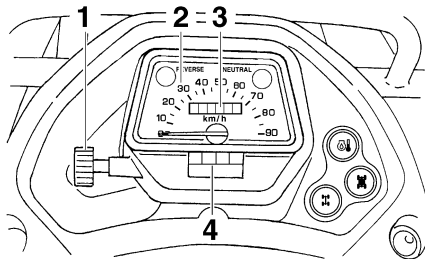

4

1. Reset knob
2. Speedometer
3. Odometer
4. Tripmeter

EBU18061

## Handlebar switches

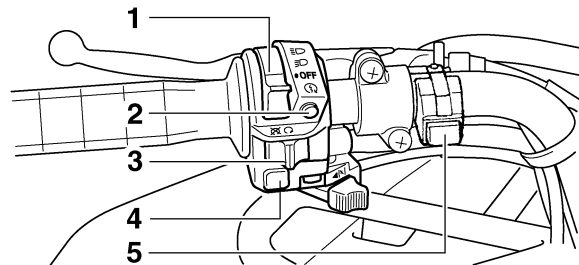

1. Light switch “ $\equiv \circ / \equiv \circ / \text{OFF}$ ”
2. Start switch “ $\text{Ⓚ}$ ”
3. Engine stop switch “ $\text{⊗} / \circ$ ”
4. Override switch “OVERRIDE”
5. Horn switch “ $\text{📯}$ ”

EBU18080

### Engine stop switch “ $\text{⊗} / \circ$ ”

Set this switch to “ $\circ$ ” before starting the engine. The engine stop switch controls the ignition and stops the engine when it is running. Use this switch to stop the engine in an emergency situation. The engine will not start or run when this switch is set to “ $\text{⊗}$ ”.

EBU18100

### Start switch “”

Push this switch to crank the engine with the starter.



ECB00050

#### **CAUTION:**

**See the starting instructions on page 6-1 prior to starting the engine.**

EBU18160

### Light switch “ / / OFF”

Set this switch to “” to turn on the low beams, the taillight and the meter lighting. Set the switch to “” to turn on the high beams, the taillight and the meter lighting. Set the switch to “OFF” to turn off all the lights.

ECB00040

#### **CAUTION:**

**Do not use the headlights with the engine turned off for an extended period of time, otherwise the battery may discharge to the point that the starter motor will not operate properly. If this should happen, remove the battery and recharge it.**

EBU18170

### Horn switch “”

Press the switch to sound the horn.

EBU28510

### Override switch “**OVERRIDE**”

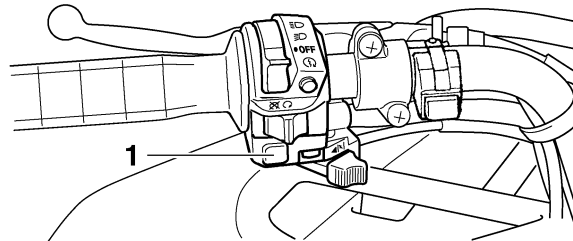

4

#### 1. Override switch “**OVERRIDE**”

Top speed is normally limited when operating in differential gear lock. If conditions require more engine power when riding forward, push and hold this switch to override the differential gear lock speed limiting function. (See page 4-7.) Releasing the switch restores the speed limiting function. While the override switch is pushed, the reverse indicator light “REVERSE” will flash.

**⚠ WARNING**

**Always ride at a slow speed when the ATV is in four-wheel-drive differential gear lock, and allow extra time and distance for maneuvers. All wheels turn at the same speed when the differential is locked, so it takes more effort to turn the ATV. The effort needed to turn increases with the riding speed. You may lose control and have an accident if you cannot make a sharp enough turn for the speed you are traveling.**

4

**On-Command four-wheel-drive switch “2WD”/“4WD”**

This ATV is equipped with a switch to change from two-wheel drive to four-wheel drive and vice-versa. Select the appropriate drive according to the terrain and the conditions.

- “2WD” (two-wheel drive): Power is supplied to the rear wheels.
- “4WD” (four-wheel drive): Power is supplied to the rear and front wheels.

To change from two-wheel drive to four-wheel drive, stop the ATV and push the switch in to the “4WD” position. The four-wheel-drive indicator light “” comes on.

To change from four-wheel drive to two-wheel drive, stop the ATV and push the switch in to the “2WD” position.

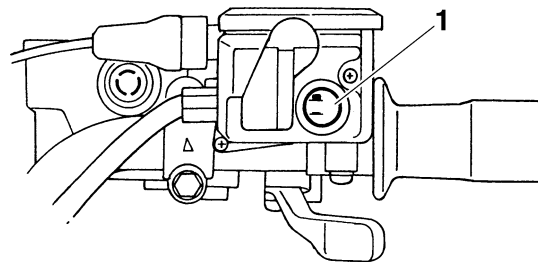

1. On-Command four-wheel-drive switch “2WD”/“4WD”

**⚠ WARNING**

**Always stop the ATV before changing from two-wheel drive to four-wheel drive and vice-versa. The ATV handles differently in two-wheel drive than in four-wheel drive in some circumstances. Changing from two-wheel**

drive to four-wheel drive or vice-versa while moving may cause the ATV to unexpectedly handle differently. This could distract the operator and increase the risk of losing control and of causing an accident.

---

EBU28370

### On-Command differential gear lock switch “4WD”/“LOCK”

This ATV is equipped with a switch allowing you to lock the differential gear when in four-wheel drive. Select the appropriate switch position according to the terrain and the conditions.

- “4WD” (four-wheel drive): Power is supplied to the rear and front wheels.
- “LOCK” (four-wheel drive with the differential gear locked): Power is supplied to the rear and front wheels and the differential gear is locked. Unlike in four-wheel drive, all wheels turn at the same speed.

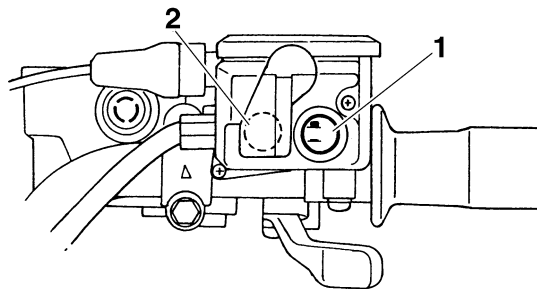

1. On-Command four-wheel-drive switch “2WD”/“4WD”
2. On-Command differential gear lock switch “4WD”/“LOCK”

To lock the differential gear in four-wheel drive, make sure the On-Command four-wheel-drive switch is pushed in to the “4WD” position.

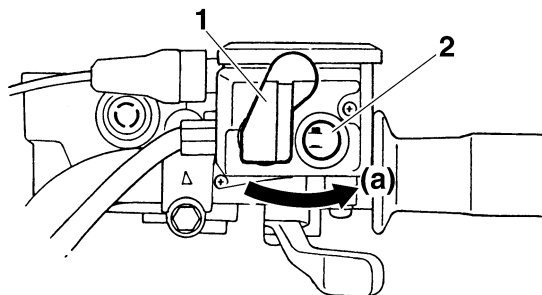

1. Differential gear lock lever
2. On-Command four-wheel-drive switch "2WD"/"4WD"

Stop the ATV, move the differential gear lock lever to position (a), and then push the differential gear lock switch in to the "LOCK" position. When the differential gear is locked, the differential gear lock indicator light  comes on.

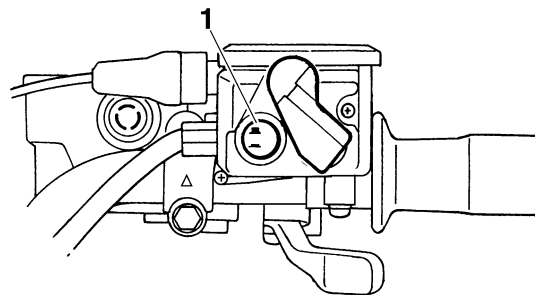

1. On-Command differential gear lock switch "4WD"/"LOCK"

To release the differential gear lock, stop the ATV and push the switch to the "4WD" position.

EWB00130

**⚠ WARNING**

**Always stop the ATV before changing from four-wheel drive to four-wheel-drive differential gear lock or vice-versa.**

**The ATV handles differently in four-wheel drive than in differential gear lock in some circumstances. Changing from four-wheel drive to differential gear lock or vice-versa while moving may cause the ATV to handle differently unex-**

pectedly. This could distract the operator and increase the risk of losing control and causing an accident.

EWB00140

**WARNING**

Always ride at a slow speed when the ATV is in differential gear lock, and allow extra time and distance for maneuvers.

All wheels turn at the same speed when the differential gear is locked, so it takes more effort to turn the ATV. The effort needed to turn increases with the riding speed. You may lose control and have an accident if you cannot make a sharp enough turn for the speed you are traveling.

**NOTE:**

- If the differential gear lock is not engaging properly, turn the handlebar back and forth to help it engage.
- Riding before the differential gear lock is properly engaged will cause the engine speed to be limited until engagement is complete.
- When the ATV is in four-wheel-drive differential gear lock, the maximum traveling speed is limited to 31 km/h (19 mi/h). However, if conditions

require full engine power to be available, push and hold the override switch to disable the differential gear lock speed limiter. (See page 4-5 for a detailed explanation of this switch.)

EBU18280

## Throttle lever

Once the engine is running, movement of the throttle lever will increase the engine speed.

Regulate the speed of the ATV by varying the throttle position. Because the throttle is spring-loaded, the ATV will decelerate, and the engine will return to an idle any time the hand is removed from the throttle lever.

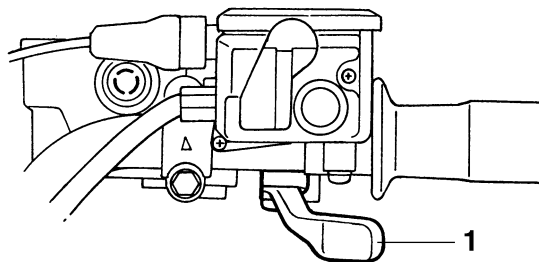

1. Throttle lever

Before starting the engine, check the throttle to be sure it is operating smoothly. Make sure it returns to the idle position as soon as the lever is released.

EWB00250

### **⚠ WARNING**

**Malfunction of the throttle could make it difficult to speed up or slow down when you need to. This could cause an accident. Check the operation of the throttle lever before you start the engine. If the throttle does not work smoothly, check for the cause. Correct the problem before riding the ATV or consult a Yamaha dealer.**

4

EBU18321

## **Speed limiter**

Your ATV was delivered with an adjustable speed limiter. The speed limiter keeps the throttle from fully opening, even when the throttle lever is pushed to the maximum.

1. Loosen the locknut.
2. To increase the maximum engine power available and the maximum speed of the ATV, turn the adjusting screw in direction (a). To decrease the maximum engine power available and the maximum speed of the ATV, turn the adjusting screw in direction (b).

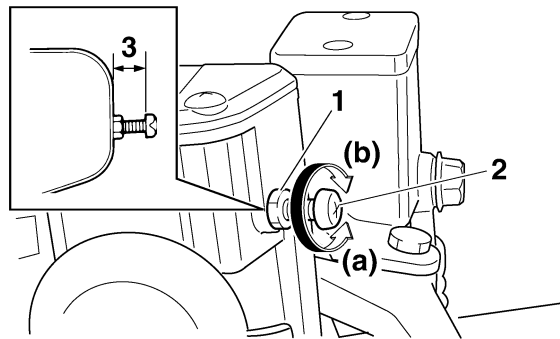

1. Locknut
  2. Adjusting screw
  3. No more than 12 mm (0.47 in)
3. Tighten the locknut.

EWB00240

### **⚠ WARNING**

**Improper adjustment of the speed limiter and throttle could cause throttle cable damage or improper throttle operation. You could lose control, have an accident or be injured. Do not turn the adjusting screw out more than 12 mm (0.47 in) or the throttle cable could be damaged. Always make sure the throttle lever free play is adjusted to 3.0–5.0 mm (0.12–0.20 in). (See page 8-26.)**



EBU18391

## Front brake lever

The front brake lever is located on the right handlebar. To apply the front brake, pull the brake lever toward the handlebar grip.

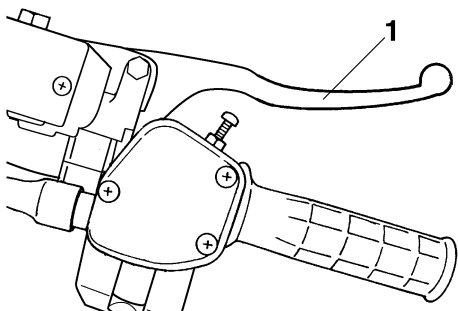

1. Front brake lever

EBU18442

## Brake pedal and rear brake lever

The brake pedal is located on the right side of the ATV and the rear brake lever is located on the left handlebar. To apply the rear brake, push down on the brake pedal or pull the brake lever toward the handlebar grip.

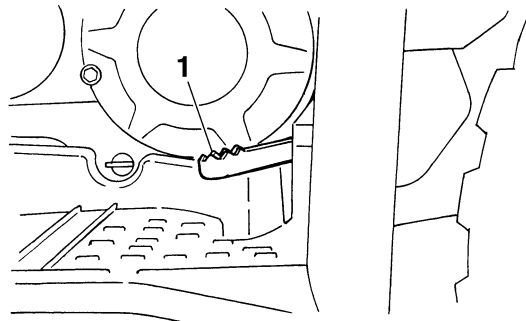

1. Brake pedal

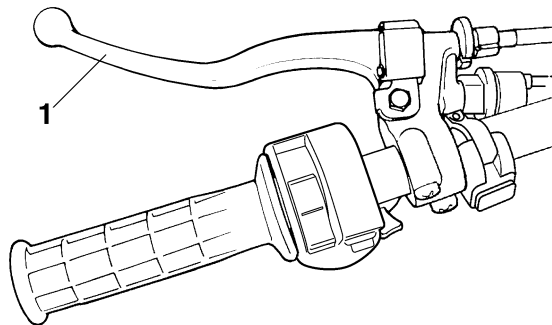

1. Rear brake lever

## Parking brake

Use the parking brake before starting the engine or parking the ATV, especially on a slope. Apply the rear brake lever and push down the lock plate to apply the parking brake. Squeeze the rear brake lever to release the parking brake.

4

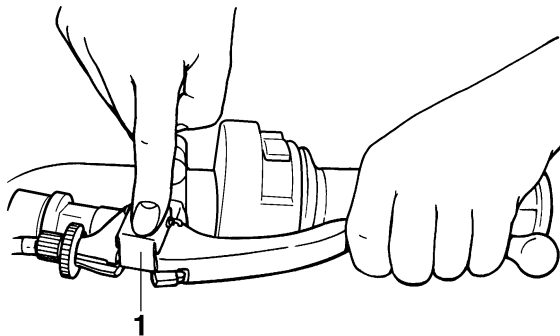

1. Parking brake lock plate

### **⚠ WARNING**

- Always set the parking brake before starting the engine. The ATV could start moving unexpectedly if the parking brake is not applied. This could cause loss of control or a collision.

- Always be sure you have released the parking brake before you begin to ride. The brake could overheat if you ride the ATV without releasing the parking brake. You could lose braking performance which could cause an accident. You could also wear out the brakes prematurely.

## Drive select lever

The drive select lever is used to shift your ATV into the forward, neutral and reverse positions. See the “Operating the drive select lever and driving in reverse” section on page 6-3 for the drive select lever operation.

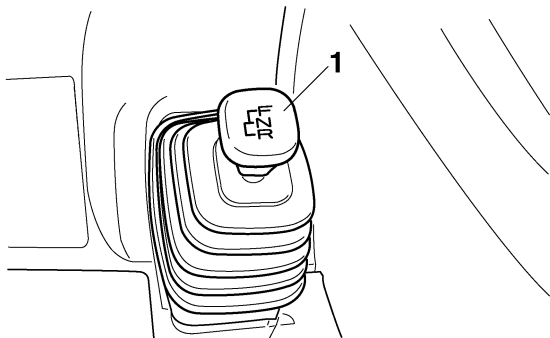

1. Drive select lever

EBU18670

## Recoil starter

Firmly grasp the handle and pull slightly until engagement can be felt. Then pull forcefully, being careful not to pull the rope all the way out.

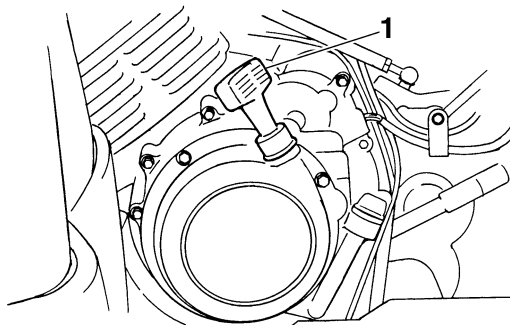

1. Recoil starter

EWB00340

## WARNING

**Shift the drive select lever into the neutral position and apply the parking brake before starting the engine, otherwise the ATV could start to move unexpectedly, which could cause an accident.**

EBU18720

## Fuel tank cap

Remove the fuel tank cap by turning it counter-clockwise.

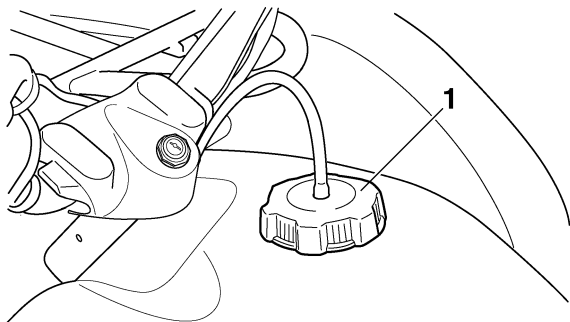

1. Fuel tank cap

EBU18750

## Fuel

Make sure that there is sufficient fuel in the tank. Fill the fuel tank to the bottom of the filler tube as shown.

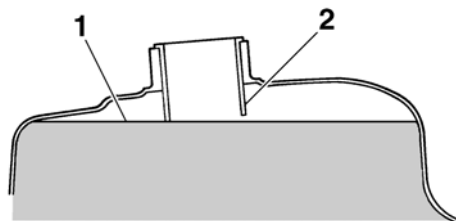

1. Fuel level
2. Fuel tank filler tube

Recommended fuel:

**UNLEADED GASOLINE ONLY**

For Europe: Regular unleaded gasoline only with a research octane number of 91 or higher

Fuel tank capacity:

13.5 L (3.57 US gal) (2.97 Imp.gal)

Fuel reserve amount:

3.3 L (0.87 US gal) (0.73 Imp.gal)

**NOTE:** \_\_\_\_\_

If knocking or pinging occurs, use a different brand of gasoline or higher octane grade.

ECB00070

**CAUTION:** \_\_\_\_\_

Use only unleaded gasoline. The use of leaded gasoline will cause severe damage to internal engine parts, such as the valves and piston rings, as well as to the exhaust system.

EWB00310

**WARNING** \_\_\_\_\_

- Do not overfill the fuel tank. Fuel expands when it heats up. If the fuel tank is overfilled, fuel could spill out due to heat from the engine or the sun.
- Be careful not to spill fuel, especially on the engine or exhaust pipe which can cause a fire and severe injury. Wipe up any spilled fuel immediately.
- Do not refuel right after the engine has been running and is still very hot.
- Be sure the fuel tank cap is closed securely.

EBU18820

## Fuel cock

The fuel cock supplies fuel from the tank to the carburetor while also filtering it.

The fuel cock lever positions are explained as follows and shown in the illustrations.

### OFF

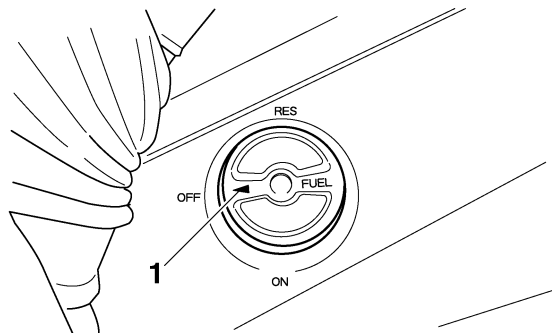

1. Arrow mark pointing to "OFF"

With the fuel cock lever in this position, fuel will not flow. Always turn the fuel cock lever to this position when the engine is not running.

ON

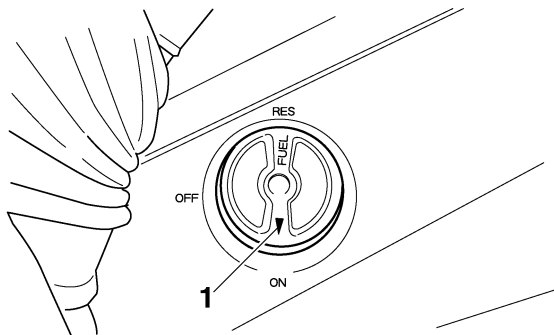

4

1. Arrow mark pointing to “ON”

With the fuel cock lever in this position, fuel flows to the carburetor. Turn the fuel cock lever to this position when starting the engine and riding.

RES

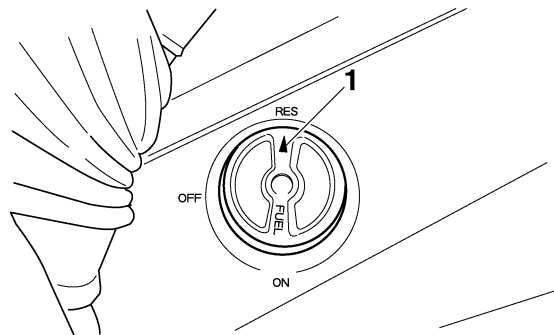

1. Arrow mark pointing to “RES”

This indicates reserve. With the fuel cock lever in this position, the fuel reserve is made available. Turn the fuel cock lever to this position if you run out of fuel while riding. When this occurs, refuel as soon as possible and be sure to turn the fuel cock lever back to “ON”!

EBU18850

**Starter (choke)** “”

Starting a cold engine requires a richer air-fuel mixture, which is supplied by the starter (choke). Move the starter (choke) in direction (a) to turn on the starter (choke).

Move the starter (choke) in direction (b) to turn off the starter (choke).  
See the “Starting a cold engine” section on page 6-1 for proper operation.

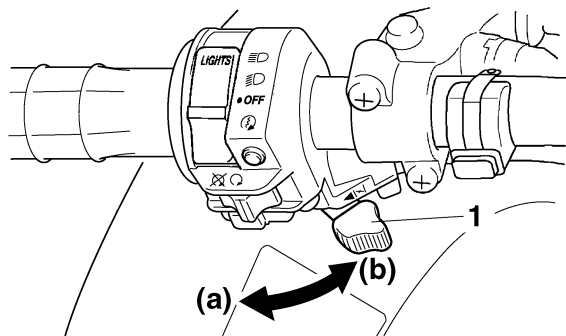

1. Starter (choke) “| \ |”

EBU18880  
**Seat**

**To remove the seat**

Pull the seat lock lever upward and pull up the seat at the rear.

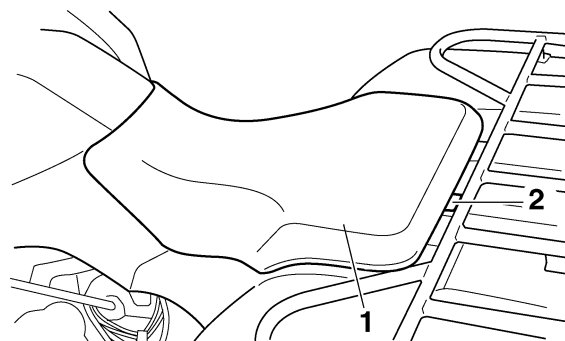

- 1. Seat
- 2. Seat lock lever

**To install the seat**

Insert the projections on the front of the seat into the seat holders and push down on the seat at the rear.

**NOTE:** \_\_\_\_\_  
Make sure that the seat is securely fitted.  
\_\_\_\_\_

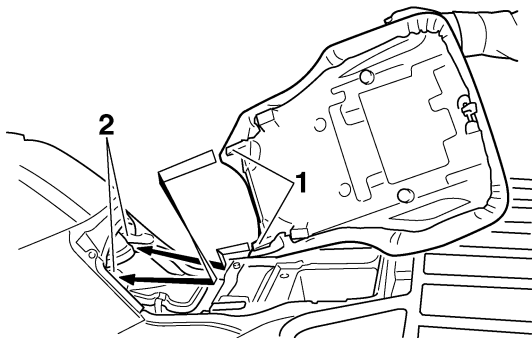

1. Projection
2. Seat holder

EBU18941

## Storage compartment

The storage compartment is located under the seat. (See page 4-17.)

When storing any documents in the storage compartment, be sure to wrap them in a plastic bag so that they will not get wet. When washing the ATV, be careful not to let any water enter the storage compartment.

ECB00130

## CAUTION:

Do not store metal or sharply edged objects, like tools, in the storage compartment. If they must be stored, wrap them in appropriate cushion material to prevent damaging the storage compartment.

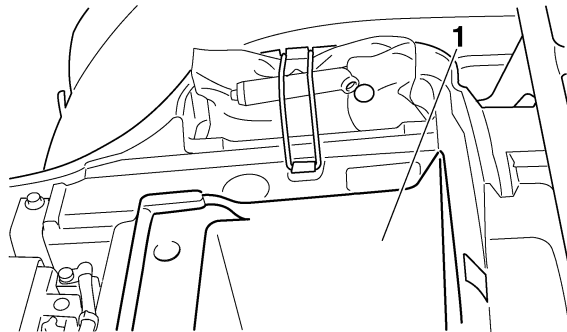

1. Storage compartment

- Do not exceed the load limit of 2.0 kg (4 lb) for the storage compartment.
- Do not exceed the maximum load of 210.0 kg (463 lb) for the ATV.



**NOTE:** \_\_\_\_\_

There is a check hose at the bottom of the storage compartment. If any water collects in this hose, remove the hose, empty it, and then install it.

---

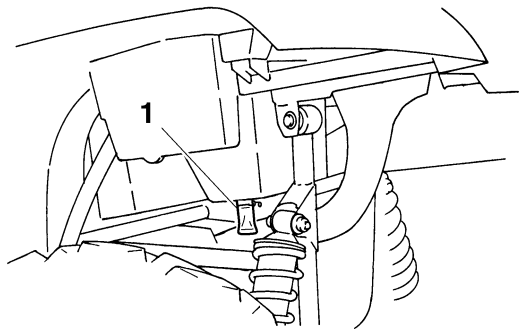

1. Storage compartment check hose

EBU18960

### Front carrier

- Do not exceed the load limit of 40.0 kg (88 lb) for the front carrier.
- Do not exceed the maximum load of 210.0 kg (463 lb) for the ATV.

EBU18970

### Rear carrier

- Do not exceed the load limit of 80.0 kg (176 lb) for the rear carrier.
- Do not exceed the maximum load of 210.0 kg (463 lb) for the ATV.

EBU19140

### Adjusting the front and rear shock absorber assemblies

The spring preload can be adjusted to suit the rider's weight and the riding conditions.

Adjust the spring preload as follows.

Turn the adjusting ring in direction (a) to increase the spring preload and thereby harden the suspension, and in direction (b) to decrease the spring preload and thereby soften the suspension.

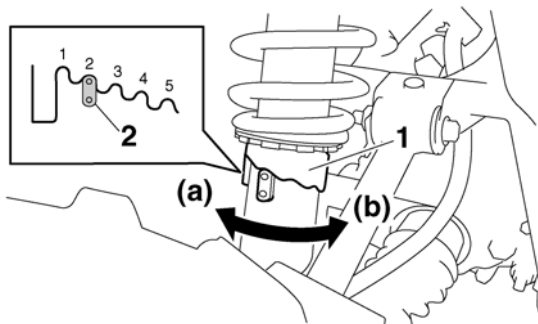

1. Spring preload adjusting ring
2. Position indicator

**NOTE:** \_\_\_\_\_

A special wrench can be obtained at a Yamaha dealer to make this adjustment.

---

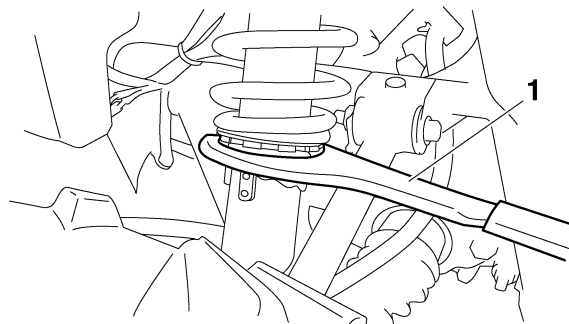

1. Special wrench

**Spring preload setting:**

Minimum (soft):

1

Standard:

2

Maximum (hard):

5



**Always adjust the shock absorber assemblies on the left and right side to the same setting. Uneven adjustment can cause poor handling and loss of stability, which could lead to an accident.**

---

# PRE-OPERATION CHECKS

EBU19220

## Pre-operation check list

Before operating this ATV, be sure to check the items listed in the following table.

### NOTE:

The maintenance of some items in the table has to be performed by a Yamaha dealer. Refer to the “Periodic maintenance and lubrication chart” on page 8-3 to determine which service should be performed by a Yamaha dealer.

5

ITEM	ROUTINE	PAGE
<b>Fuel</b>	<ul style="list-style-type: none"> <li>• Check fuel level in fuel tank, and add recommended fuel if necessary.</li> <li>• Check fuel line for leakage. Correct if necessary.</li> </ul>	4-14, 5-3
<b>Engine oil</b>	<ul style="list-style-type: none"> <li>• Check oil level in engine, and add recommended oil to specified level if necessary.</li> <li>• Check ATV for oil leakage. Correct if necessary.</li> </ul>	5-3, 8-10
<b>Final gear oil</b>	<ul style="list-style-type: none"> <li>• Check ATV for oil leakage. Correct if necessary.</li> </ul>	5-3, 8-14
<b>Differential gear oil</b>	<ul style="list-style-type: none"> <li>• Check ATV for oil leakage. Correct if necessary.</li> </ul>	5-3, 8-17
<b>Front brake</b>	<ul style="list-style-type: none"> <li>• Check operation. If soft or spongy, have Yamaha dealer bleed hydraulic system.</li> <li>• Check brake pads for wear, and replace if necessary.</li> <li>• Check brake fluid level in reservoir, and add recommended brake fluid to specified level if necessary.</li> <li>• Check hydraulic system for leakage. Correct if necessary.</li> </ul>	5-3, 8-27, 8-28, 8-29
<b>Rear brake</b>	<ul style="list-style-type: none"> <li>• Check operation, and correct if necessary.</li> <li>• Lubricate cables if necessary.</li> <li>• Check lever and pedal free play, and adjust if necessary.</li> </ul>	5-3, 8-27, 8-30

ITEM	ROUTINE	PAGE
Throttle lever	<ul style="list-style-type: none"> <li>• Make sure that operation is smooth. Lubricate cable and lever housing if necessary.</li> <li>• Check cable free play, and adjust if necessary.</li> </ul>	5-4, 8-26
Control cables	<ul style="list-style-type: none"> <li>• Make sure that operation is smooth. Lubricate if necessary.</li> </ul>	8-36
Wheels and tires	<ul style="list-style-type: none"> <li>• Check wheel condition, and replace if damaged.</li> <li>• Check tire condition and tread depth. Replace if necessary.</li> <li>• Check air pressure. Correct if necessary.</li> </ul>	5-4, 5-5, 5-6
Brake pedal	<ul style="list-style-type: none"> <li>• Make sure that operation is smooth. Lubricate pedal pivoting point if necessary.</li> </ul>	8-37
Brake levers	<ul style="list-style-type: none"> <li>• Make sure that operation is smooth. Lubricate lever pivoting points if necessary.</li> </ul>	8-36
Axle boots	<ul style="list-style-type: none"> <li>• Check for cracks or damage, and replace if necessary.</li> </ul>	8-34
Chassis fasteners	<ul style="list-style-type: none"> <li>• Make sure that all nuts, bolts and screws are properly tightened.</li> </ul>	5-7
Instruments, lights and switches	<ul style="list-style-type: none"> <li>• Check operation, and correct if necessary.</li> </ul>	5-7

EWB00480



**Always inspect your ATV each time you use it to make sure it is in safe operating condition. Always follow the inspection and maintenance procedures and schedules described in the Owner's Manual. Failure to inspect increases the possibility of an accident or equipment damage.**

EBU19540

## Fuel

Make sure that there is sufficient fuel in the tank. (See page 4-14.)

EWB00520

### WARNING

- **Do not overfill the fuel tank. Fuel expands when it heats up. If the fuel tank is overfilled, fuel could spill out due to heat from the engine or the sun.**
- **Be careful not to spill fuel, especially on the engine or exhaust pipe which can cause a fire and severe injury. Wipe up any spilled fuel immediately.**
- **Do not refuel right after the engine has been running and is still very hot.**
- **Be sure the fuel tank cap is closed securely.**

EBU19560

## Engine oil

Make sure that the engine oil is at the specified level. Add oil as necessary. (See page 8-10.)

EBU19590

## Final gear oil

Make sure that the final gear oil is at the specified level. Add oil as necessary. (See page 8-14.)

EBU19600

## Differential gear oil

Make sure that the differential gear oil is at the specified level. Add oil as necessary. (See page 8-17.)

EBU28530

## Front and rear brakes

### Brake levers and brake pedal

- Check that there is no free play in the front brake lever. If there is free play, have a Yamaha dealer check the brake system.
- Check for correct free play in the rear brake lever and brake pedal. If the free play is incorrect, adjust it. (See page 8-30.)
- Check operation of the levers and pedal. They should move smoothly and there should be a firm feeling when the brake is applied. If not, have a Yamaha dealer check them.

### Brake fluid level (front brake)

Check the brake fluid level. Add fluid if necessary. (See page 8-28.)

Recommended brake fluid:  
DOT 4

## Brake fluid leakage (front brake)

Check to see if any brake fluid is leaking out of the hose, joint or brake fluid reservoir of the front brake. Apply the brake firmly for one minute. If the lever moves slowly inward, there may be a leak in the brake system. If there is any leakage, the brake system should be checked by a Yamaha dealer.

## Brake operation

Test the brakes at slow speed after starting out to make sure they are working properly. If the brakes do not provide proper braking performance, check the brake pads and friction plates for wear. (See page 8-27.)

EWB00580



**Always check the brakes at the start of every ride. Do not ride the ATV if you find any problem with the brakes or you could lose braking ability, which could lead to an accident. If a problem cannot be corrected by the adjustment procedures provided in this manual, have a Yamaha dealer check for the cause.**

---

EBU19761

## Throttle lever

Check the operation of the throttle lever. It must open smoothly and spring back to the idle position when released. Have a Yamaha dealer correct if necessary.

EBU19811

## Tires

EWB00591



**Use of improper tires on this ATV, or operation of this ATV with improper or uneven tire pressure, may cause loss of control, increasing your risk of accident.**

**Pay attention to the following.**

- The tires listed below have been approved by Yamaha Motor Manufacturing Corporation of America for this model. Other tire combinations are not recommended.

**Front:**

**Manufacturer/model:**

**CHENG SHIN/C-828 (AUS)(NZL)**

**MAXXIS/M979 (EUR)(GBR)**

**Size:**

**AT25 x 8-12**

Type:

Tubeless

Rear:

Manufacturer/model:

CHENG SHIN/C-828 (AUS)(NZL)

MAXXIS/M980 (EUR)(GBR)

Size:

AT25 x 10-12

Type:

Tubeless

- The tires should be set to the recommended pressure:

Recommended tire pressure:

Front:

25.0 kPa (3.6 psi) (0.250 kgf/cm<sup>2</sup>)

Rear:

25.0 kPa (3.6 psi) (0.250 kgf/cm<sup>2</sup>)

- Check and adjust tire pressures when the tires are cold.
- Tire pressures must be equal on both sides.
- Tire pressure below the minimum specified could cause the tire to dislodge from the rim under severe riding conditions.

Minimum tire pressure:

Front:

22.0 kPa (3.2 psi) (0.220 kgf/cm<sup>2</sup>)

Rear:

22.0 kPa (3.2 psi) (0.220 kgf/cm<sup>2</sup>)

- Use no more than the following pressures when seating the tire beads.

Maximum tire seating pressure:

Front:

250 kPa (36 psi) (2.5 kgf/cm<sup>2</sup>)

Rear:

250 kPa (36 psi) (2.5 kgf/cm<sup>2</sup>)

Higher pressures and fast inflation may cause a tire to burst. Inflate the tires very slowly and carefully.

EBU19820

## Measuring the tire pressure

Use the low-pressure tire gauge.

**NOTE:** \_\_\_\_\_

The low-pressure tire gauge is included as standard equipment. Make two measurements of the tire pressure and use the second reading. Dust or dirt in the gauge could cause the first reading to be incorrect.



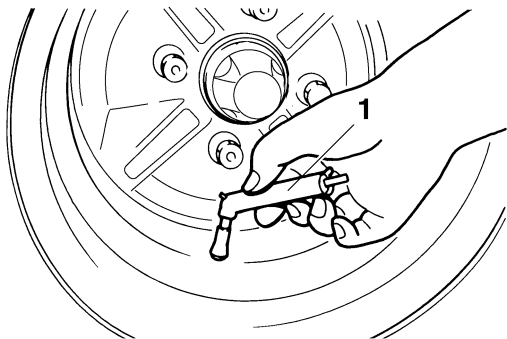

1. Low-pressure tire gauge

Set the tire pressure when the tires are cold. Set the tire pressures to the following specifications:

Recommended pressure:

Front

25.0 kPa (3.6 psi) (0.250 kgf/cm<sup>2</sup>)

Rear

25.0 kPa (3.6 psi) (0.250 kgf/cm<sup>2</sup>)

Minimum:

Front

22.0 kPa (3.2 psi) (0.220 kgf/cm<sup>2</sup>)

Rear

22.0 kPa (3.2 psi) (0.220 kgf/cm<sup>2</sup>)

Maximum:

Front

28.0 kPa (4.1 psi) (0.280 kgf/cm<sup>2</sup>)

Rear

28.0 kPa (4.1 psi) (0.280 kgf/cm<sup>2</sup>)

EBU19830

### Tire wear limit

Replace the tire when the tire groove decreases to 3 mm (0.12 in).

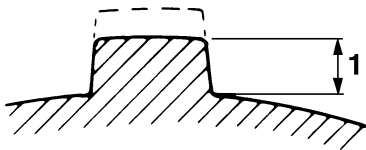

5

#### 1. Tire wear limit

EBU19840

### **Chassis fasteners**

Make sure that all nuts, bolts and screws are properly tightened.

EBU19850

### **Instruments, lights and switches**

Check that all instruments, lights and switches are working properly. Correct if necessary.

# OPERATION

Read the Owner's Manual carefully before riding the ATV.

EWB00630



## WARNING

Read the Owner's Manual carefully to become familiar with all controls in order to help prevent any loss of control, which could cause an accident or injury. If there is a control or function you do not understand, ask your Yamaha dealer.

EBU20031

## Starting a cold engine

EWB00640



## WARNING

Always make sure all control cables work smoothly before you begin riding in cold weather. If the control cables are frozen or do not work smoothly, you could be unable to control the ATV, which could lead to an accident or collision.

ECB00150

## CAUTION:

See the "Engine break-in" section on page 6-4 prior to operating the engine for the first time.

1. Set the parking brake.
2. Turn the fuel cock to "ON".
3. Turn the main switch to "ON" and the engine stop switch to "○".
4. Shift the drive select lever into the neutral position. The neutral indicator light should come on. If the indicator light does not come on, have a Yamaha dealer check the electrical circuit.

## NOTE:

The engine can be started under the following conditions:

- The drive select lever is in the neutral position.
- The rear brake lever is applied with the drive select lever in any position. However, it is recommended to shift into the neutral position before starting the engine.

5. Use the starter (choke) in reference to the figure:

**Position (1):**

Cold engine start with ambient temperature below 5 °C (40 °F).

**Position (2):**

Cold engine start with ambient temperature between 0 °C (30 °F) and 30 °C (90 °F).

**Position (3):**

Cold engine start with ambient temperature above 25 °C (80 °F).

**6 Ambient temp./starter (choke) position**

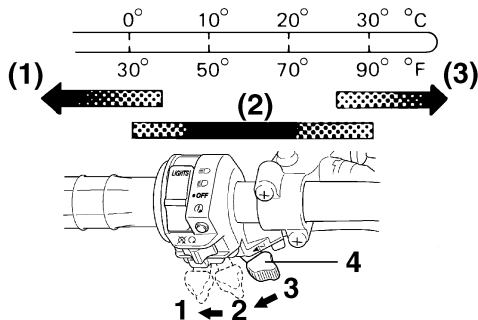

1. Fully open
2. Half open
3. Closed
4. Starter (choke)

6. Completely close the throttle lever and start the engine by pushing the start switch.

**NOTE:** \_\_\_\_\_

- If the engine fails to start, release the start switch, then push it again. Pause a few seconds before the next attempt. Each cranking should be as short as possible to preserve battery energy. Do not crank the engine more than 10 seconds on each attempt.
- If the battery is discharged, pull the recoil starter to start the engine.

7. If the engine is started with the starter (choke) in position (1), the starter (choke) should be returned to position (2) to warm up the engine. If the engine is started with the starter (choke) in position (2), keep the starter (choke) in this position to warm up the engine.

ECB00160

**CAUTION:** \_\_\_\_\_

**For maximum engine life, always warm the engine up before starting off. Never accelerate hard when the engine is cold!**

8. Continue warming up the engine until it idles smoothly, then return the starter (choke) to position (3) before riding.

**NOTE:** \_\_\_\_\_

The engine is warm when it responds normally to the throttle with the starter (choke) turned off.

EBU20291

## Starting a warm engine

Follow the same procedure as for starting a cold engine, with the exception that the starter (choke) is not required when the engine is warm. Instead, start the engine with the throttle slightly open.

EBU20380

## Operating the drive select lever and driving in reverse

ECB00170

**CAUTION:** \_\_\_\_\_

**Before shifting, stop the ATV, otherwise the transmission may be damaged.**

### Shifting: Forward

1. Bring the ATV to a complete stop.
2. Shift from neutral to forward and vice versa by moving the drive select lever along the shift guide.

**NOTE:** \_\_\_\_\_

Make sure that the drive select lever is completely shifted into position.

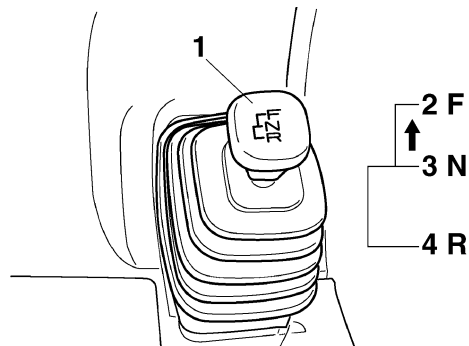

1. Drive select lever
2. F (Forward)
3. N (Neutral)
4. R (Reverse)

3. Open the throttle lever gradually.

### Shifting: Reverse

1. Bring the ATV to a complete stop.
2. Apply the brake pedal.

- Shift from neutral to reverse and vice versa by moving the drive select lever along the shift guide.

**NOTE:**

When in reverse, the reverse indicator light should come on. If the indicator light does not come on, have a Yamaha dealer check the electrical circuit.

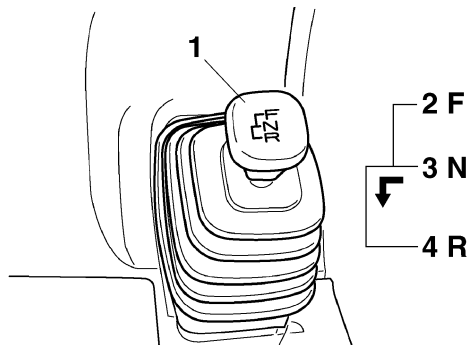

- Drive select lever
- F (Forward)
- N (Neutral)
- R (Reverse)

- Check behind for people or obstacles, and then release the brake pedal.

- Open the throttle lever gradually and continue to watch to the rear while backing.

EWB00720



**Improper operation in reverse could make you hit an obstacle or even a person behind you, resulting in serious injury. When you shift into reverse, make sure there are no people or obstacles behind you. When it is safe to proceed, go slowly.**

EBU20682

## Engine break-in

**NOTE:**

- For ATVs equipped with an odometer or an hour meter, follow the figures given in km (mi) or the figures given in hours.
- For ATVs not equipped with an odometer or hour meter, follow the figures given in hours.

There is never a more important period in the life of your engine than the first 320 km (200 mi) or 20 hours of riding. For this reason, you should read the following material carefully.

Since the engine is brand new, do not put an excessive load on it for the first 320 km (200 mi) or 20 hours. The various parts in the engine wear and

polish themselves to the correct operating clearances. During this period, prolonged full-throttle operation or any condition that might result in engine overheating must be avoided.

### **0–160 km (0–100 mi) or 0–10 hours**

Avoid prolonged operation above 1/2 throttle. Vary the speed of the ATV regularly. Do not operate it at one set throttle position.

### **160–320 km (100–200 mi) or 10–20 hours**

Avoid prolonged operation above 3/4 throttle. Rev the engine freely, but do not use full throttle at any time.

### **320 km (200 mi) or 20 hours and beyond**

The ATV can now be operated normally.

ECB00220

#### **CAUTION:**

**If any engine trouble should occur during the engine break-in period, immediately have a Yamaha dealer check the ATV.**

EBU20700

## **Parking**

When parking the ATV, stop the engine, shift the drive select lever into the forward position, apply the parking brake, and then turn the fuel cock to “OFF”.

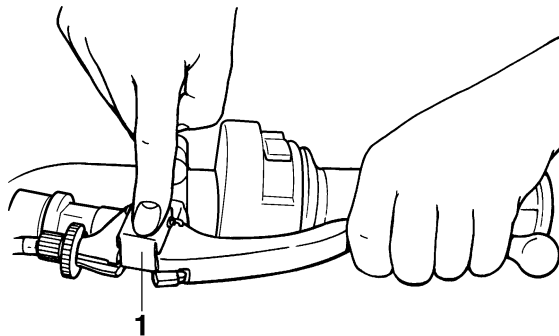

1. Parking brake lock plate

EBU20760

## **Parking on a slope**

EWB00830

### **! WARNING**

**Avoid parking on hills or other inclines. Parking on a hill or other incline could cause the ATV to roll out of control, increasing the chance of an accident. If you must park on an**

incline, place the ATV transversely across the incline, shift the drive select lever to the forward position, stop the engine, apply the parking brake, and then block the front and rear wheels with rocks or other objects.

**Do not park the ATV at all on hills that are so steep you could not walk up them easily.**

1. Bring the ATV to a stop by applying the brakes in the forward position.
2. Stop the engine.
3. With the rear brake lever and pedal applied, apply the parking brake, and then slowly release the brake pedal.

6

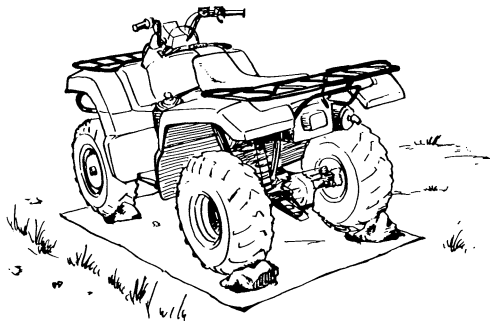

EBU20910

## Accessories and loading

EBU20920

### Accessories

Accessories can affect the handling and control of your ATV. Keep the following in mind when considering an accessory or operating an ATV which has accessories.

- Choose only accessories designed for your ATV. Your Yamaha dealer has a variety of genuine Yamaha accessories. Other accessories may also be available on the market. However, it is not possible for Yamaha to test all non-Yamaha accessories, nor control over their quality or suitability. Choose a genuine Yamaha accessory, or one that is equivalent in design and quality.
- Accessories should be rigidly and securely mounted. An accessory which can shift position or come off while you are riding could affect your ability to control the ATV.
- Do not mount an accessory where it could interfere with your ability to control the ATV. Examples include (but are not limited to) a heavy or bulky object attached to the handlebars which



could make steering difficult, an accessory that limits your ability to move around on the seat, or one that limits your view.

- Use extra caution when riding an ATV with accessories. The ATV may handle differently than it does without accessories.

EBU21060

### **Loading**

Cargo or a trailer can change the stability and handling of an ATV.

You must use common sense and good judgment when carrying cargo or towing a trailer. Keep the following points in mind:

- Never exceed the weight limits shown. An overloaded ATV can be unstable.

#### **MAXIMUM LOADING LIMIT**

ATV loading limit (total weight of rider, cargo, accessories, and tongue):

210.0 kg (463 lb)

Front carrier:

40.0 kg (88 lb)

Rear carrier:

80.0 kg (176 lb)

Storage compartment:

2.0 kg (4 lb)

Trailer hitch:

Pulling load (total weight of trailer and cargo):

4900 N (1102 lbf) (500 kgf)

Tongue weight (vertical weight on trailer hitch point):

147 N (33 lbf) (15 kgf)

- Do not exceed the maximum tongue weight. You can measure tongue weight with a bathroom scale. Put the tongue of the loaded trailer on the scale with the tongue at hitch height. Adjust the load in the trailer, if necessary, to reduce the weight on the hitch. If you are carrying cargo and towing a trailer, include the tongue weight in the maximum ATV load limit.

- Load cargo on the carriers as close to the center of the ATV as possible. Put cargo at the rear of the front carrier, at the front of the rear carrier, and center it.
- Tie down cargo securely to the carriers. Make sure cargo in the trailer cannot move around. A shifting load can cause an accident.
- Make sure the load does not interfere with controls or your ability to see where you are going.
- Ride more slowly than you would without a load. The more weight you carry, the slower you should go.
- Allow more braking distance. A heavier ATV takes longer to stop.
- Avoid making sharp turns unless at very slow speeds.
- Avoid hills and rough terrain. Choose terrain carefully. Added weight affects the stability and handling of the ATV.

EWP00820

** WARNING**

**Never exceed the stated load capacity for this ATV. Overloading this ATV or carrying or towing cargo improperly could cause changes in ATV handling which could lead to an accident. Cargo should be properly distributed and se-**

**curely attached. Reduce speed when carrying cargo or pulling a trailer. Allow greater distance for braking.**

---

# RIDING YOUR ATV

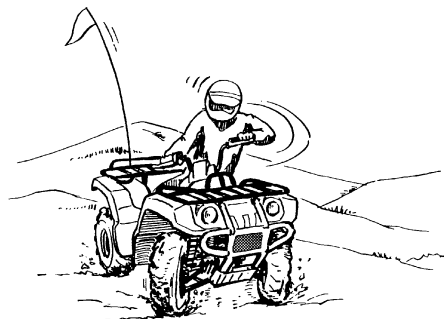
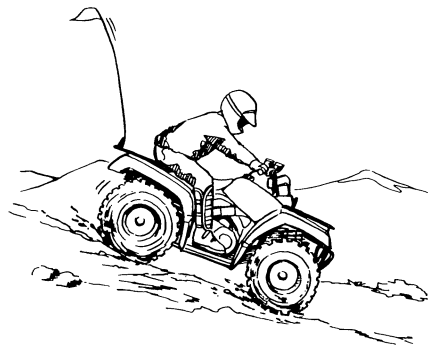
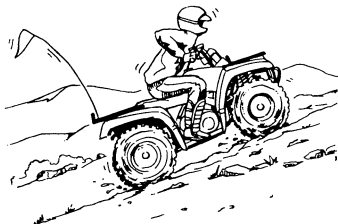
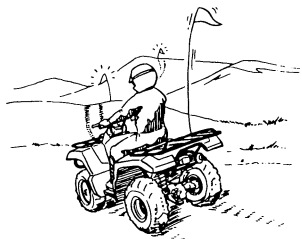

## GETTING TO KNOW YOUR ATV

This ATV is for recreation and utility use. This section, *Riding your ATV*, provides general ATV riding instructions for recreational riding. The skills and techniques described in this section, however, are appropriate for all types of riding. Riding your ATV requires special skills acquired through practice over a period of time. Take the time to learn the basic techniques well before attempting more difficult maneuvers.

7

Riding your new ATV can be a very enjoyable activity, providing you with hours of pleasure. But it is essential to familiarize yourself with the operation of the ATV to achieve the skill necessary to enjoy riding safely. Before you begin to ride, be sure you have read this Owner's Manual completely and understand the operation of the controls. Pay particular attention to the safety information on pages 1-1-1-4. Please also read all caution and warning labels on your ATV.

## RIDE WITH CARE AND GOOD JUDGEMENT

### Get training if you are inexperienced.

Beginners should get training from a certified instructor.

Become familiar with this ATV at slow speeds first, even if you are an experienced operator. Do not attempt to operate at maximum performance until you are totally familiar with the ATV's handling and performance characteristics.

EWB01380



---

**Never operate this ATV without proper instruction. Beginning and inexperienced operators should regularly practice the skills and the operating techniques described in this Owner's Manual. The risk of an accident is greatly increased if the operator does not know how to operate the ATV properly in different situations and on different types of terrain.**

---

**Riding your ATV requires skills acquired through practice over a period of time.**

Take the time to learn the basic techniques well before attempting more difficult maneuvers.

Not recommended for children under 16 years of age.

EWB01390

**⚠ WARNING**

A child under 16 should never operate an ATV with engine size greater than 90 cc. Use by children of ATVs that are not recommended for their age can lead to severe injury or death of the child.

---



This ATV is designed to carry operator and cargo only – passengers prohibited.

EWB01400

**⚠ WARNING**

Never carry a passenger. The long seat is to allow the operator to shift position as needed during operation. It is not for carrying passengers. Carrying a passenger on this ATV greatly reduces your ability to balance and control this ATV. It could cause an accident, resulting in harm to you and/or your passenger.

---



## Apparel

Always wear an approved motorcycle helmet that fits properly.

You should also wear:

- eye protection (goggles or face shield)
- gloves
- boots
- long-sleeved shirt or jacket
- long pants

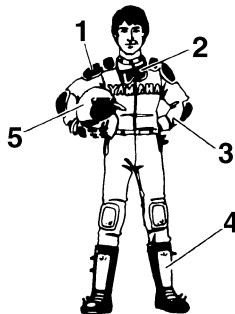

1. Protective clothing
2. Goggles
3. Gloves
4. Boots
5. Helmet

**⚠ WARNING**

Never operate this ATV without wearing an approved motorcycle helmet, eye protection and protective clothing. Operating without an approved motorcycle helmet increases your chances of a severe head injury or death in the event of an accident. Operating without eye protection can result in an accident and increases your chances of a severe injury in the event of an accident. Operating without protective clothing increases your chances of severe injury in the event of an accident.

**Do not operate after consuming alcohol or drugs.**

The operator's performance capability is reduced by the influence of alcohol or drugs.

**⚠ WARNING**

Never consume alcohol or drugs before or while driving this ATV.

**Pre-operation checks**

Always perform the pre-operation checks listed on page 5-1 before riding for proper care of the ATV and to ensure safety.

**⚠ WARNING**

Always inspect your ATV each time you use it to make sure the ATV is in safe operating condition. Always follow the inspection and maintenance procedures and schedules described

in the Owner's Manual. Failure to inspect the ATV before operating or failure to properly maintain the ATV increases the possibility of an accident or equipment damage.

EWB01440

**⚠ WARNING**

Always use the size and type tires specified in the Owner's Manual for this ATV on page 5-4. Always maintain proper tire pressure as described in the Owner's Manual on page 5-5. Use of improper tires on this ATV, or operation of this ATV with improper or uneven tire pressure, may cause loss of control, increasing your risk of an accident.

7

Do not operate at speeds too fast for your skills or the conditions.

EWB01450

**⚠ WARNING**

Always go at a speed that is proper for the terrain, visibility and operating conditions, and your experience. Operating this ATV at speeds too fast for your skills or the conditions increases your chances of losing control of the ATV, which can result in an accident.

### Speed limiter

For riders less experienced with this model, the throttle lever housing is equipped with a speed limiter. The speed limiter keeps the throttle from fully opening, even when the throttle lever is pushed to the maximum. Turning in the adjusting screw limits the maximum engine power available and decreases the maximum speed of the ATV. Turning in the adjusting screw decreases top speed, and turning it out increases top speed. (See page 4-10.)

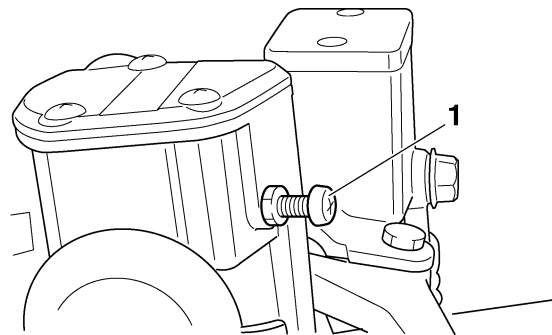

1. Adjusting screw



## Loading and accessories

Use extra caution when riding the ATV with additional loads, such as accessories or cargo. The ATV's handling may be adversely affected. Reduce your speed when adding additional loads.

### MAXIMUM LOADING LIMIT

ATV loading limit (total weight of cargo, rider, accessories, and tongue):

210.0 kg (463 lb)

Front carrier:

40.0 kg (88 lb)

Rear carrier:

80.0 kg (176 lb)

Storage compartment:

2.0 kg (4 lb)

Trailer hitch:

Pulling load (total weight of trailer and cargo):

4900 N (1102 lbf) (500 kgf)

Tongue weight (vertical weight on trailer hitch point):

147 N (33 lbf) (15 kgf)

EWB01460



- **Never exceed the stated load capacity for this ATV.**
- **Cargo should be properly distributed and securely attached.**
- **Reduce speed when carrying cargo or pulling a trailer. Allow greater distance for braking.**
- **Always follow the instructions in your Owner's Manual for carrying cargo or pulling a trailer.**

### During operation

Always keep your feet on the footboards during operation, otherwise they may contact the rear wheels.

7

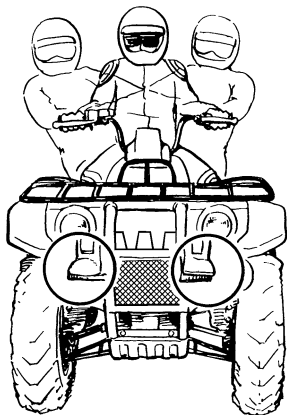

7

EWB01470

**⚠ WARNING**

Always keep both hands on the handlebars and both feet on the footboards of your ATV during operation. Removing even one hand or foot can reduce your ability to control the ATV or could cause you to lose your balance and fall off of the ATV. If you remove a foot from a footboard, your foot or leg may come into contact with the rear wheels, which could injure you or cause an accident.

Avoid wheelies and jumping. You may lose control of the ATV or overturn.

EWB01480

**⚠ WARNING**

Never attempt stunts, such as wheelies or jumps. Don't try to show off.

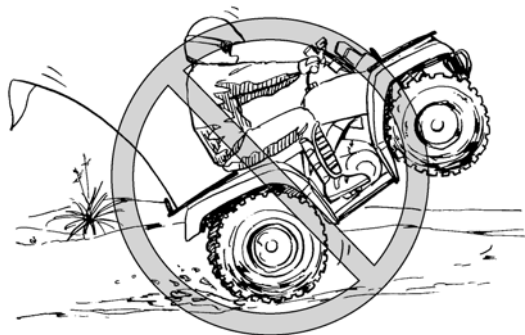

**Modifications**

EWB01490

**⚠ WARNING**

Never modify this ATV through improper installation or use of accessories. All parts and accessories added to this ATV should be genuine Yamaha or equivalent components designed for use on this ATV and should be

installed and used according to instructions. Improper installation of accessories or modification of this ATV may cause changes in handling which in some situations could lead to an accident. If you have questions, consult an authorized ATV dealer.

---

### Exhaust system

The exhaust system on the ATV is very hot during and following operation. To prevent burns, avoid touching the exhaust system. Park the ATV in a place where pedestrians or children are not likely to touch it. Also, avoid parking in or around dry grass, brush or other combustible materials to prevent causing a fire hazard.

EWB01500

#### **WARNING**

- Do not touch the hot exhaust system.
  - Do not park the ATV during or after operation in a place where others might be likely to touch it.
  - Do not operate, idle, or park the ATV in dry grass, dry ground cover, or combustible materials.
- 

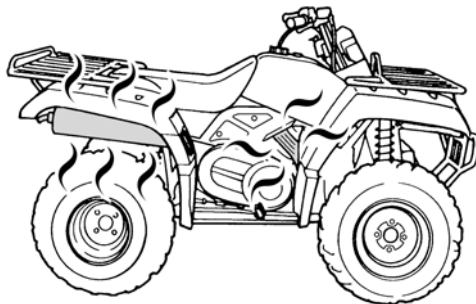

### BE CAREFUL WHERE YOU RIDE

This ATV is designed for use on unpaved surfaces only. Riding on paved surfaces can cause loss of control.

EWB01510

#### **WARNING**

Always avoid paved surfaces, including sidewalks, driveways, parking lots and streets. ATVs are designed for use on unpaved surfaces only. Paved surfaces may seriously affect handling and control of the ATV, and may cause the ATV to go out of control.

---

**! WARNING**

Never operate this ATV on any paved street, paved road or motorway. You can collide with another vehicle. In many areas, it is illegal to operate ATVs on public streets, roads and highways.

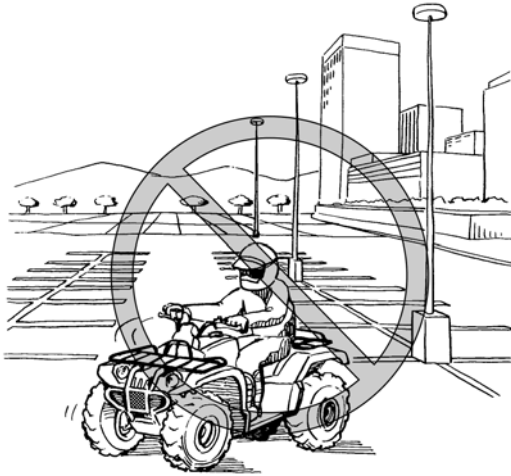

7

While riding on unpaved public streets or roads may be legal in your area, such operation can increase the risk of collision with other vehicles. Watch carefully for other vehicles. Make sure you know your country's laws and regulations before you ride on unpaved public streets or roads. Do not ride on any paved public street, road or motorway.

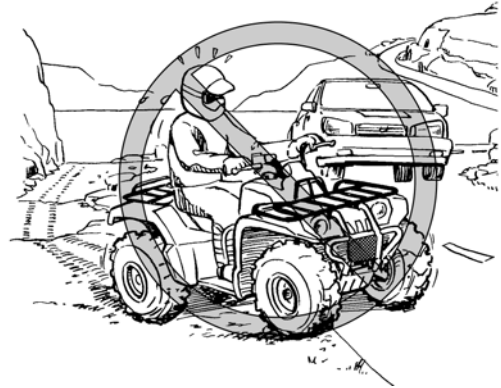

Know the terrain where you ride. Ride cautiously in unfamiliar areas. Stay alert for **holes, rocks, or roots** in the terrain, and **other hidden hazards** which may cause the ATV to upset.

**⚠ WARNING**

Go slowly and be extra careful when operating on unfamiliar terrain. Always be alert to changing terrain conditions when operating the ATV.

**⚠ WARNING**

Do not operate on excessively rough, slippery or loose terrain until you have learned and practiced the skills necessary to control the

ATV on such terrain. Failure to use extra care when operating on excessively rough, slippery or loose terrain could cause loss of traction or ATV control, which could result in an accident, including an overturn.



When riding in an area where you might not easily be seen, such as desert terrain, mount a caution flag on the ATV. DO NOT use the flag pole bracket as a trailer hitch.

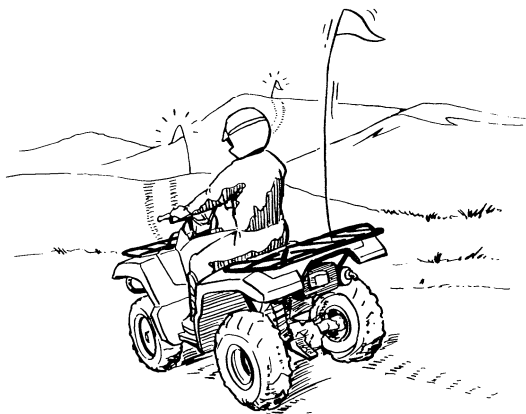

7

EWB01550

**WARNING**

**Always mount a caution flag on the ATV to make you more visible when operating in areas where you might not be seen by other vehicles. Watch carefully for other vehicles.**

Do not ride in areas posted “no trespassing”.  
Do not ride on private property without getting permission.

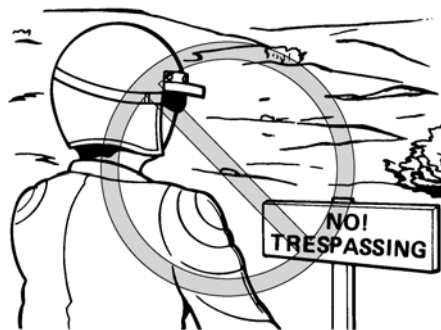

Select a large, flat, unpaved area to become familiar with your ATV. Make sure that this area is free of obstacles and other riders. You should practice control of the throttle, brakes, and turning techniques in this area before trying more difficult terrain. Always avoid riding on paved surfaces: the ATV is designed for use on unpaved surfaces only, and handling maneuvers are more difficult to perform on pavement.

Set the parking brake and follow the instruction on page 6-1 to start the engine. Once it has warmed up you are ready to begin riding your ATV. Remember that the engine and exhaust pipe will be hot when riding and afterwards; do not allow skin or clothing to come in contact with these components.

With the engine idling, return the starter (choke) to the closed position, shift the drive select lever into the forward position, and then release the parking brake. Apply the throttle slowly and smoothly. The centrifugal clutch will engage and you will start to accelerate. If the throttle is applied too abruptly, the front wheels may lift off the ground, resulting in a loss of directional control. Avoid higher speeds until you are thoroughly familiar with the operation of your ATV.

When slowing down or stopping, release the throttle and apply the brakes smoothly and evenly. Improper use of the brakes can cause the tires to lose traction, reducing control and increasing the possibility of an accident.

## TURNING YOUR ATV

To achieve maximum traction on unpaved surfaces in 2WD or 4WD, the two rear wheels turn together at the same speed. Furthermore, when riding in 4WD-LOCK (“DIFF. LOCK”), the front wheels also turn together at the same speed. Therefore, unless the wheel on the inside of the turn is allowed to slip or lose some traction, the ATV will resist turning. A special turning technique

must be used to allow the ATV to make turns quickly and easily. It is essential that this skill be learned first at low speed.

EWB01770



**Always follow proper procedures for turning as described in this Owner’s Manual. Practice turning at low speeds before attempting to turn at faster speeds. Do not turn at speeds too fast for your skills or the conditions. Operate at a slow speed and allow extra time and distance for maneuvers when in 4WD-LOCK (“DIFF. LOCK”).**

As you approach a curve, slow down and begin to turn the handlebars in the desired direction. As you do so, put your weight on the footboard to the outside of the turn (opposite your desired direction) and lean your upper body into the turn. Use the throttle to maintain an even speed through the turn. This maneuver will let the wheel on the inside of the turn slip slightly, allowing the ATV to make the turn properly.

7

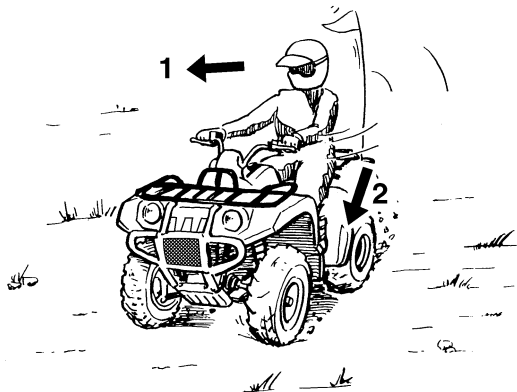

1. Lean towards inside of turn.
2. Support your weight on the outer footboard.

This procedure should be practiced at slow speed many times in a large unpaved area with no obstacles. If an incorrect technique is used, your ATV may continue to go straight. If the ATV doesn't turn, come to a stop and then practice the procedure again. If the riding surface is slippery or loose, it may help to position more of your weight over the front wheels by moving forward on the seat.

Once you have learned this technique, you should be able to perform it at higher speeds or in tighter curves.

Improper riding procedures such as abrupt throttle changes, excessive braking, incorrect body movements, or too much speed for the sharpness of the turn may cause the ATV to tip. If the ATV begins to tip over to the outside while negotiating a turn, lean more to the inside. It may also be necessary to gradually let off on the throttle and steer to the outside of the turn to avoid tipping over.

Remember: Avoid higher speeds until you are thoroughly familiar with the operation of your ATV.

### **CLIMBING UPHILL**

Use proper riding techniques to avoid ATV over- turns on hills. Be sure that you can maneuver your ATV well on flat ground before attempting any incline and then practice riding first on gentle slopes. Try more difficult climbs only after you have developed your skill. In all cases avoid inclines with slippery or loose surfaces, or obstacles that might cause you to lose control.



**WARNING**

Never operate the ATV on hills too steep for the ATV or for your abilities. The ATV can overturn more easily on extremely steep hills than on level surfaces or small hills. Practice on smaller hills before attempting large hills.

It is important when climbing a hill to make sure that your weight is transferred forward on the ATV. This can be accomplished by leaning forward and, on steeper inclines, standing on the footboards and leaning forward over the handlebars.

**WARNING**

- Always follow proper procedures for climbing hills as described in this Owner's Manual.
- Always check the terrain carefully before you start up any hill.
- Never climb hills with excessively slippery or loose surfaces.
- Shift your weight forward.
- Never open the throttle suddenly. The ATV could flip over backwards.

- Never go over the top of any hill at high speed. An obstacle, a sharp drop, or another vehicle or person could be on the other side of the hill.

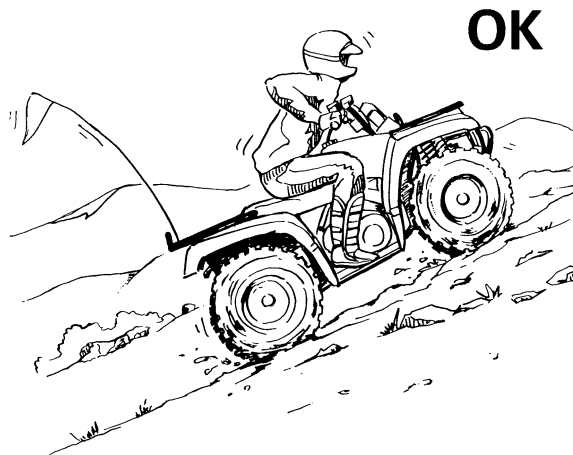

If you are climbing a hill and you find that you have not properly judged your ability to make it to the top, you should turn the ATV around while you still have forward motion (provided you have the room to do so) and go down the hill.

**⚠ WARNING**

Never attempt to turn the ATV around on any hill until you have mastered the turning technique as described in the Owner's Manual on level ground. Be very careful when turning on any hill. Avoid crossing the side of a steep hill if possible.

When crossing the side of a hill:

- Always follow proper procedures as described in the Owner's Manual.
- Avoid hills with excessively slippery or loose surfaces.
- Shift your weight to the uphill side of the ATV.

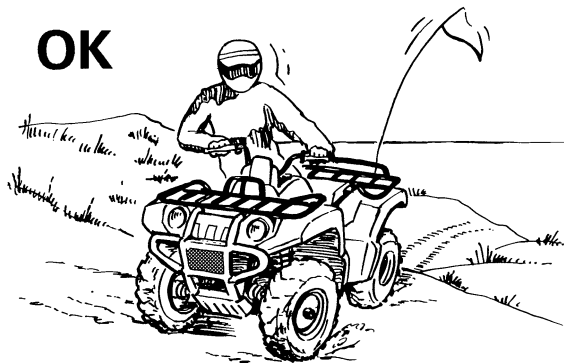
**OK**

If your ATV has stalled or stopped and you believe you can continue up the hill, restart carefully to make sure you do not lift the front wheels which could cause you to lose control. If you are unable to continue up the hill, dismount the ATV on the uphill side. Physically turn the ATV around and then descend the hill.

If you start to roll backwards, DO NOT apply either brake abruptly. If you are in 2WD, apply only the front brake. If you are in 4WD or 4WD-LOCK, because all wheels are interconnected by the drive train, applying either brake will brake all wheels, therefore, avoid sudden application of either the front or rear brake as the wheels on the uphill side

could come off the ground. The ATV could easily tip over backwards. Apply both the front and rear brakes gradually, or dismount the ATV immediately on the uphill side.

EWB02450

**WARNING**

**Maintain a steady speed when climbing a hill.**

**If you lose all forward speed:**

- **Keep weight uphill.**
- **Apply the brakes.**
- **Apply the parking brake after you are stopped.**

**If you begin rolling backwards:**

- **Keep weight uphill.**
- **2WD: Never apply the rear brake while rolling backwards. Apply the front brake. When fully stopped, apply the rear brake as well, and then lock the parking brake.**
- **4WD or 4WD-LOCK: Apply both front and rear brakes gradually. When fully stopped, lock the parking brake.**

**Dismount on uphill side or to a side if pointed straight uphill. Turn the ATV around and remount, following the procedure described in the Owner's Manual.**

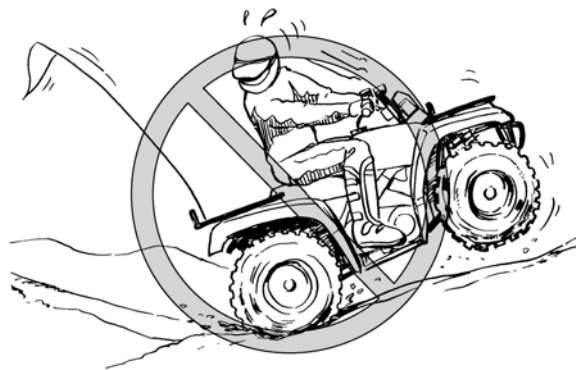

### **RIDING DOWNHILL**

When riding your ATV downhill, shift your weight as far to the rear and uphill side of the ATV as possible. Move back on the seat and sit with your arms straight. Engine compression will do most of the braking for you. For maximum engine compression braking effect, change to 4WD or 4WD-LOCK before beginning to descend the hill. Improper braking may cause a loss of traction.

Use caution while descending a hill with loose or slippery surfaces. Braking ability and traction may be adversely affected by these surfaces. Improper braking may also cause a loss of traction.

When this ATV is in 4WD or 4WD-LOCK, all wheels (front and rear) are interconnected by the drive train. This means that applying either the front brake or the rear brake will brake all wheels. When descending hills, using either brake lever or the brake pedal will brake the wheels on the downhill side. Avoid sudden application of either the front or rear brake because the wheels on the uphill side could come off the ground. Apply both the front and rear brakes gradually.

Whenever possible, ride your ATV straight downhill. Avoid sharp angles which could allow the ATV to tip or roll over. Carefully choose your path and ride no faster than you will be able to react to obstacles which may appear.

EWB01620

**⚠ WARNING**

**Always follow proper procedures for going down hills as described in this Owner's Manual.**

**Note: a special technique is required when braking as you go down a hill.**

- **Always check the terrain carefully before you start down any hill.**
- **Shift your weight backward.**
- **Never go down a hill at high speed.**

- **Avoid going down a hill at an angle that would cause the ATV to lean sharply to one side. Go straight down the hill where possible.**

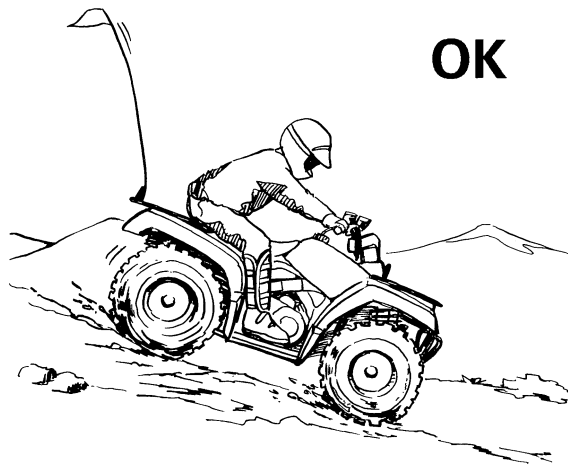

**CROSSING A SLOPE**

Traversing a sloping surface on your ATV requires you to properly position your weight to maintain proper balance. Be sure that you have learned the basic riding skills on flat ground before attempting

to cross a sloping surface. Avoid slopes with slippery surfaces or rough terrain that may upset your balance.

As you travel across a slope, lean your body in the uphill direction. It may be necessary to correct the steering when riding on loose surfaces by pointing the front wheels slightly uphill. When riding on slopes, be sure not to make sharp turns either up or down hill.

If your ATV does begin to tip over, gradually steer in the downhill direction if there are no obstacles in your path. As you regain proper balance, gradually steer again in the direction you wish to travel.

EWB01631

**WARNING**

**Never attempt to turn the ATV around on any hill until you have mastered the turning technique as described in the Owner's Manual on level ground. Be very careful when turning on any hill. Avoid crossing the side of a steep hill if possible.**

**When crossing the side of a hill:**

- **Always follow proper procedures as described in the Owner's Manual.**
- **Avoid hills with excessively slippery or loose surfaces.**

- **Shift your weight to the uphill side of the ATV.**

**OK**



**CROSSING THROUGH SHALLOW WATER**

The ATV can be used to cross slow moving, shallow water of up to a maximum of 35 cm (14 in) in depth. Before entering the water, choose your path carefully. Enter where there is no sharp drop off, and avoid rocks or other obstacles which may be slippery or upset the ATV. Drive slowly and carefully.

**⚠ WARNING**

Never operate this ATV in fast flowing water or in water deeper than that specified in your Owner's Manual. Remember that wet brakes may have reduced stopping ability. Test your brakes after leaving water. If necessary, apply them several times to let friction dry out the linings. If the ATV is operated through deep or fast flowing water, the tires may float, causing loss of traction and loss of control, which could lead to an accident.

7

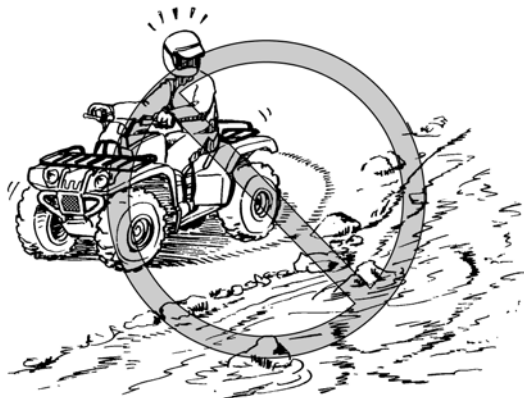

Test your brakes after leaving the water. Do not continue to ride your ATV without verifying that you have regained proper braking ability.

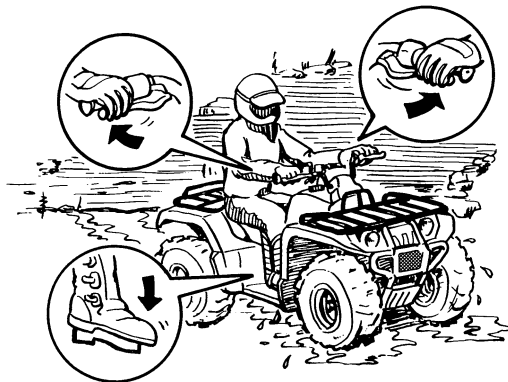

ECB00280

**CAUTION:**

After riding your ATV in water, be sure to drain the trapped water by removing the check hose at the bottom of the air filter case, the V-belt cooling duct check hose, the drive select lever box check hose and the storage compartment check hose. Also, remove the V-belt case drain

**plug to drain any water that may have accumulated. Wash the ATV in fresh water if it has been operated in salt water or muddy conditions.**

---

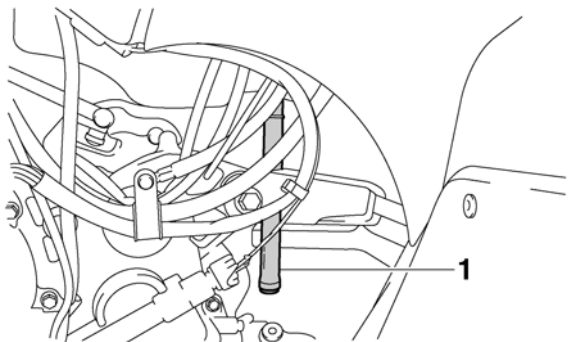

1. Air filter case check hose

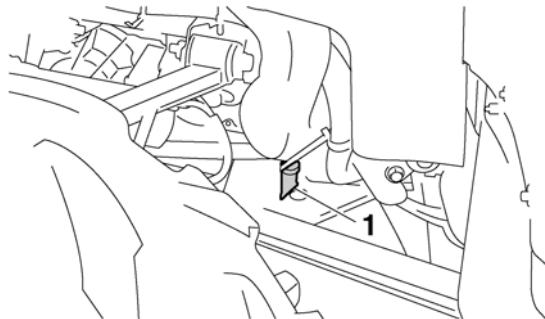

1. V-belt cooling duct check hose (left front side of ATV)

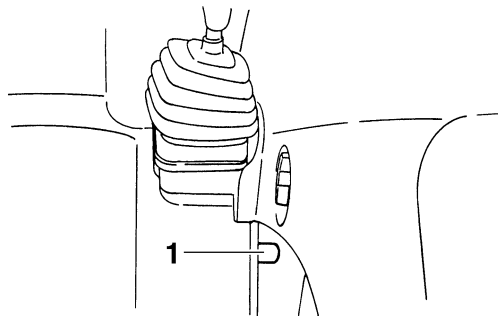

1. Drive select lever box check hose

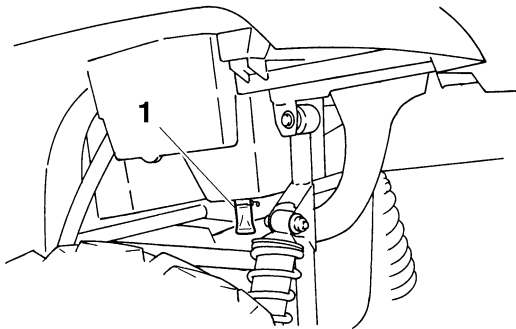

1. Storage compartment check hose

7

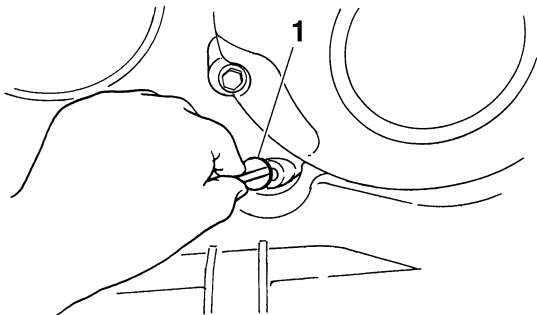

1. V-belt case drain plug

## RIDING OVER ROUGH TERRAIN

Riding over rough terrain should be done with caution. Look out for obstacles which could cause damage to the ATV or could lead to an upset or accident. Be sure to keep your feet firmly mounted on the footboards at all times. Avoid jumping the ATV as loss of control and damage to the ATV may result.

EWB01650

### **WARNING**

**Before operating in a new area, check for obstacles. Never attempt to ride over large obstacles, such as large rocks or fallen trees. When you go over obstacles, always follow proper procedures as described in the Owner's Manual.**

## SLIDING AND SKIDDING

Care should be used when riding on loose or slippery surfaces since the ATV may slide. If unexpected and uncorrected, sliding could lead to an accident.

To reduce the tendency for the front wheels to slide in loose or slippery conditions, positioning your weight over the front wheels will sometimes help.



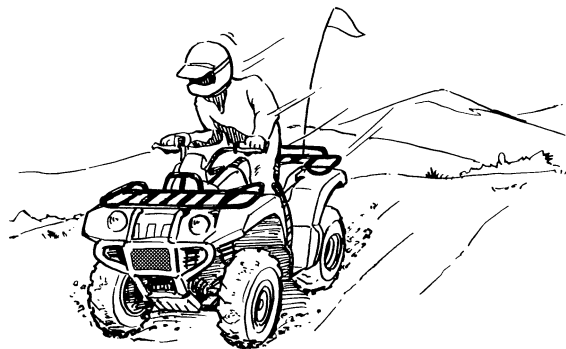

If the rear wheels of your ATV start to slide sideways, control can usually be regained (if there is room to do so) by steering in the direction of the slide. Applying the brakes or accelerating is not recommended until you have corrected the slide.

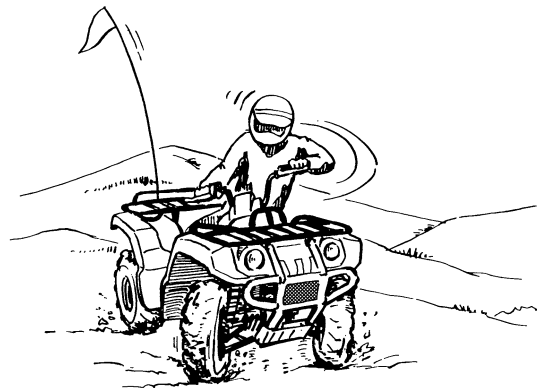

With practice, over a period of time, skill at controlled sliding can be developed. The terrain should be chosen carefully before attempting such maneuvers, since both stability and control are reduced. Bear in mind that sliding maneuvers should always be avoided on extremely slippery surfaces such as ice, since all control may be lost.

EWB01661

**⚠ WARNING**

**Learn to safely control skidding or sliding by practicing at low speeds and on level, smooth terrain.**

**On extremely slippery surfaces, such as ice, go slowly and be very cautious in order to reduce the chance of skidding or sliding out of control.**

---

### **WHAT TO DO IF...**

This section is designed to be a reference guide only. Be sure to read each section on riding techniques completely.

### **WHAT TO DO...**

- If your ATV doesn't turn when you want it to: Bring the ATV to a stop and practice the turning maneuvers again. Be sure you are putting your weight on the footboard to the outside of the turn. Position your weight over the front wheels for better control. (See page 7-13.)
- If your ATV begins to tip while turning: Lean more into the turn to regain balance. If necessary, gradually let off the throttle and/or steer to the outside of the turn. (See page 7-13.)
- If your ATV starts to slide sideways: Steer in the direction of the slide if you have the room. Applying the brakes or accelerating is not recommended until you have corrected the slide. (See page 7-22.)

- If your ATV can't make it up a hill you are trying to climb:  
Turn the ATV around if you still have forward speed. If not, stop, dismount on the uphill side of the ATV and physically turn the ATV around. If the ATV starts to slip backwards, **DO NOT USE THE REAR BRAKE IF THE ATV IS IN 2WD** – the ATV may tip over on top of you. Dismount the ATV on the uphill side. (See page 7-14.)
- If your ATV is traversing a sloping surface:  
Be sure to ride with your weight positioned towards the uphill side of the ATV to maintain proper balance. If the ATV starts to tip, steer down the hill (if there are no obstacles in your way) to regain balance. If you discover that the ATV is going to tip over, dismount on the uphill side. (See page 7-14.)
- If your ATV encounters shallow water:  
Ride slowly and carefully through slow moving water, watching for obstacles. Be sure to let water drain from the ATV and **CHECK YOUR BRAKES FOR PROPER OPERATION** when you come out of the water. Do not continue to ride your ATV until you have regained adequate braking ability. (See page 7-19.)

## PERIODIC MAINTENANCE AND MINOR REPAIR

Safety is an obligation of the owner. Periodic inspection, adjustment and lubrication will keep your ATV in the safest and best operating condition possible. The most important points of inspection, adjustment, and lubrication are explained on the following pages.

The intervals given in the periodic maintenance and lubrication chart should be considered as a general guide under normal riding conditions. However, **DEPENDING ON THE WEATHER, TERRAIN, GEOGRAPHICAL LOCATION, AND INDIVIDUAL USE, THE MAINTENANCE INTERVALS MAY NEED TO BE SHORTENED.**



### WARNING

**Never service an engine while it is running. Moving parts can catch clothing or parts of the body, causing injury. Electrical components can cause shocks or start fires. Turn off the engine when performing maintenance unless**

**otherwise specified. Have a Yamaha dealer perform the service if you are not familiar with maintenance work.**

### Owner's manual and tool kit

Be sure to put this owner's manual in the plastic bag and always carry it on the bottom of the seat as shown. Put the owner's tool kit and low-pressure tire gauge under the seat.

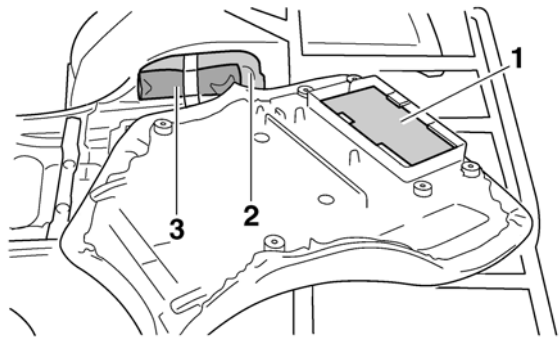

1. Owner's manual
2. Owner's tool kit
3. Low-pressure tire gauge

The service information included in this manual and the tools provided in the owner's tool kit are intended to assist you in the performance of preventive maintenance and minor repairs. However, additional tools such as a torque wrench may be necessary to perform certain maintenance work correctly.

**NOTE:** \_\_\_\_\_

If you do not have the tools or experience required for a particular job, have a Yamaha dealer perform it for you.

---

EWB01850

 **WARNING** \_\_\_\_\_

**8**

**Never modify this ATV through improper installation or use of accessories, as it may cause changes in handling, which in some situations could lead to an accident. All parts and accessories added to this ATV should be genuine Yamaha or equivalent components designed for use on this ATV and should be installed and used according to instructions. If you have questions, consult an authorized Yamaha ATV dealer.**

---

## Periodic maintenance and lubrication chart

### NOTE:

- For ATVs not equipped with an odometer or an hour meter, follow the month maintenance intervals.
- For ATVs equipped with an odometer or an hour meter, follow the km (mi) or hours maintenance intervals. However, keep in mind that if the ATV isn't used for a long period of time, the month maintenance intervals should be followed.
- Items marked with an asterisk should be performed by a Yamaha dealer as they require special tools, data and technical skills.

NO.	ITEM	CHECK OR MAINTENANCE JOB	Whichever comes first →	INITIAL			EVERY		
				month	1	3	6	6	12
				km (mi)	320 (200)	1200 (750)	2400 (1500)	2400 (1500)	4800 (3000)
				hours	20	75	150	150	300
1	*	Fuel line	• Check fuel hoses for cracks or other damage, and replace if necessary.				√	√	√
2		Spark plug	• Check condition and clean, regap, or replace if necessary.	√	√	√	√	√	√
3	*	Valves	• Check valve clearance and adjust if necessary.	√		√	√	√	√
4		Air filter element	• Clean and replace if necessary.	Every 20–40 hours (more often in wet or dusty areas)					
5	*	Front brake	• Check operation and correct if necessary. • Check fluid level and ATV for fluid leakage, and correct if necessary.	√	√	√	√	√	√
			• Replace brake pads.	Whenever worn to the limit					

NO.	ITEM	CHECK OR MAINTENANCE JOB	Whichever comes first ⇒	INITIAL			EVERY		
				month	1	3	6	6	12
				km (mi)	320 (200)	1200 (750)	2400 (1500)	2400 (1500)	4800 (3000)
hours	20	75	150	150	300				
6	*	<b>Rear brake</b>	<ul style="list-style-type: none"> <li>• Check operation and correct if necessary.</li> <li>• Check brake lever and pedal free play, and adjust if necessary.</li> </ul>	√	√	√	√	√	
			<ul style="list-style-type: none"> <li>• Replace brake friction plates.</li> </ul>	Whenever worn to the limit					
7	*	<b>Brake hoses</b>	<ul style="list-style-type: none"> <li>• Check for cracks or other damage, and replace if necessary.</li> </ul>		√	√	√	√	
			<ul style="list-style-type: none"> <li>• Replace.</li> </ul>	Every 4 years					
8	*	<b>Wheels</b>	<ul style="list-style-type: none"> <li>• Check runout and for damage, and replace if necessary.</li> </ul>	√		√	√	√	
9	*	<b>Tires</b>	<ul style="list-style-type: none"> <li>• Check tread depth and for damage, and replace if necessary.</li> <li>• Check air pressure and balance, and correct if necessary.</li> </ul>	√		√	√	√	
10	*	<b>Wheel bearings</b>	<ul style="list-style-type: none"> <li>• Check for looseness or damage, and replace if necessary.</li> </ul>	√		√	√	√	
11	*	<b>V-belt</b>	<ul style="list-style-type: none"> <li>• Check for wear, cracks or other damage, and replace if necessary.</li> </ul>	√		√	√	√	
12	*	<b>Drive shaft universal joint</b>	<ul style="list-style-type: none"> <li>• Lubricate with lithium-soap-based grease.</li> </ul>			√	√	√	
13	*	<b>Chassis fasteners</b>	<ul style="list-style-type: none"> <li>• Make sure that all nuts, bolts, and screws are properly tightened.</li> </ul>	√	√	√	√	√	
14	*	<b>Shock absorber assemblies</b>	<ul style="list-style-type: none"> <li>• Check operation and correct if necessary.</li> <li>• Check for oil leakage and replace if necessary.</li> </ul>			√	√	√	
15	*	<b>Stabilizer bushes</b>	<ul style="list-style-type: none"> <li>• Check for cracks or other damage, and replace if necessary.</li> </ul>			√	√	√	

NO.	ITEM	CHECK OR MAINTENANCE JOB	Whichever comes first ⇒	INITIAL			EVERY		
				month	1	3	6	6	12
				km (mi)	320 (200)	1200 (750)	2400 (1500)	2400 (1500)	4800 (3000)
hours	20	75	150	150	300				
16	* Knuckle pivots	• Lubricate with lithium-soap-based grease.			√	√	√		
17	* Steering shaft	• Lubricate with lithium-soap-based grease.			√	√	√		
18	* Steering system	• Check operation and repair or replace if damaged. • Check toe-in and adjust if necessary.	√	√	√	√	√		
19	* Engine mount	• Check for cracks or other damage, and replace if necessary.			√	√	√		
20	* Axle boots	• Check for cracks or other damage, and replace if necessary.	√	√	√	√	√		
21	* Carburetor	• Check starter (choke) operation and correct if necessary. • Check engine idling speed and adjust if necessary.		√	√	√	√		
22	* Crankcase breather system	• Check breather hose for cracks or other damage, and replace if necessary.			√	√	√		
23	Engine oil	• Change. • Check ATV for oil leakage, and correct if necessary.	√		√	√	√		
24	Engine oil filter cartridge	• Replace.	√		√		√		
25	Differential gear oil	• Change. • Check ATV for oil leakage, and correct if necessary.	√				√		
26	Final gear oil	• Change. • Check ATV for oil leakage, and correct if necessary.	√		√	√			

NO.	ITEM	CHECK OR MAINTENANCE JOB	Whichever comes first ⇒	INITIAL			EVERY		
				month	1	3	6	6	12
				km (mi)	320 (200)	1200 (750)	2400 (1500)	2400 (1500)	4800 (3000)
hours	20	75	150	150	300				
27	* Moving parts and cables	• Lubricate.			√	√	√	√	
28	* Drive select lever safety system cable	• Check operation and adjust or replace if necessary.				√	√	√	
29	* Throttle lever housing and cable	• Check operation and correct if necessary. • Check throttle cable free play and adjust if necessary. • Lubricate throttle lever housing and cable.	√	√	√	√	√	√	
30	* Exhaust system	• Check for leakage and replace gasket(s) if necessary. • Check for looseness and tighten all screw clamps and joints if necessary.				√	√	√	
31	Spark arrester	• Clean.				√	√	√	
32	* Front and rear brake switches	• Check operation and correct if necessary.	√	√	√	√	√	√	
33	* Lights and switches	• Check operation and correct if necessary. • Adjust headlight beams.	√	√	√	√	√	√	

EBU28390

**NOTE:**

- The air filter needs more frequent service if you are riding in unusually wet or dusty areas.
- Hydraulic brake service
  - Regularly check and, if necessary, correct the brake fluid level.



- Every two years replace the internal components of the brake master cylinder and calipers, and change the brake fluid.
  - Replace the brake hoses every four years and if cracked or damaged.
-

## Removing and installing the panel

The panel shown needs to be removed to perform some of the maintenance jobs described in this chapter. Refer to this section each time the panel needs to be removed and installed.

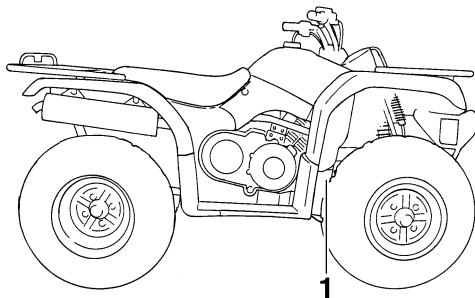

1. Panel A

### Panel A

#### To remove the panel

Remove the bolt, and then take the panel off.

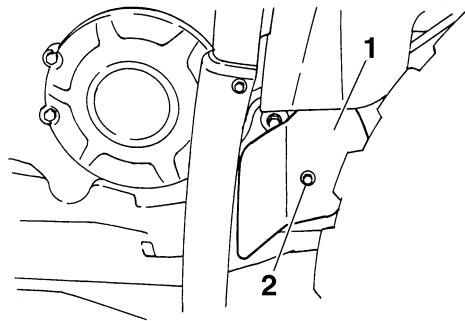

1. Panel A
2. Bolt

#### To install the panel

Place the panel in the original position and install the bolt.

ECB00380

#### **CAUTION:**

**When installing the panel, be sure not to pinch the cables or wires.**

EBU23211

### Checking the spark plug

The spark plug is an important engine component, which is easy to check. Since heat and deposits will cause any spark plug to slowly erode, the spark

plug should be removed and checked in accordance with the periodic maintenance and lubrication chart. In addition, the condition of the spark plug can reveal the condition of the engine.

### To remove the spark plug

1. Remove the spark plug cap.

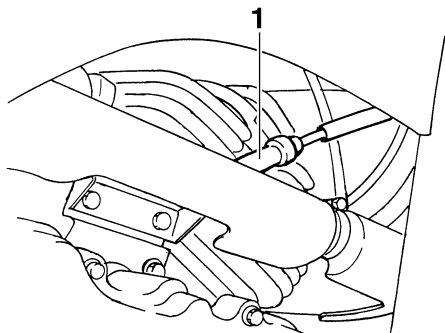

1. Spark plug cap

2. Remove the spark plug as shown, with the spark plug wrench included in the owner's tool kit.

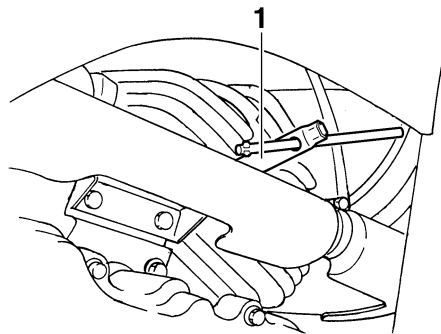

1. Spark plug wrench

### To check the spark plug

1. Check that the porcelain insulator around the center electrode of the spark plug is a medium-to-light tan (the ideal color when the ATV is ridden normally).

#### **NOTE:**

If the spark plug shows a distinctly different color, the engine could be operating improperly. Do not attempt to diagnose such problems yourself. Instead, have a Yamaha dealer check the ATV.

2. Check the spark plug for electrode erosion and excessive carbon or other deposits, and replace it if necessary.

Specified spark plug:  
NGK/DR8EA

### To install the spark plug

1. Measure the spark plug gap with a wire thickness gauge and, if necessary, adjust the gap to specification.

Spark plug gap:  
0.6–0.7 mm (0.024–0.028 in)

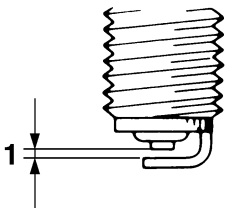

1. Spark plug gap
2. Clean the surface of the spark plug gasket and its mating surface, and then wipe off any grime from the spark plug threads.

3. Install the spark plug with the spark plug wrench, and then tighten it to the specified torque.

Tightening torque:  
Spark plug:  
17.5 Nm (1.75 m·kgf, 12.7 ft·lbf)

### NOTE:

If a torque wrench is not available when installing a spark plug, a good estimate of the correct torque is 1/4–1/2 turn past finger tight. However, the spark plug should be tightened to the specified torque as soon as possible.

4. Install the spark plug cap.

EBU23312

### Engine oil and oil filter cartridge

The engine oil level should be checked before each ride. In addition, the oil must be changed and the oil filter cartridge replaced at the intervals specified in the periodic maintenance and lubrication chart.

### To check the engine oil level

1. Place the ATV on a level surface.

2. Check the engine oil level on a cold engine.

**NOTE:** \_\_\_\_\_

If the engine was started before checking the oil level, be sure to warm up the engine sufficiently, and then wait at least ten minutes until the oil settles for an accurate reading.

3. Remove the engine oil filler cap, and then wipe the dipstick off with a clean rag.

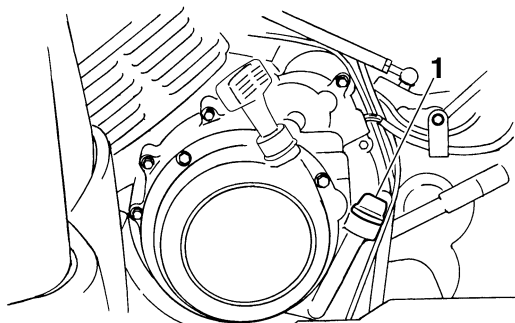

1. Engine oil filler cap

4. Insert the dipstick into the filler hole (without screwing it in), and then remove it again to check the oil level.

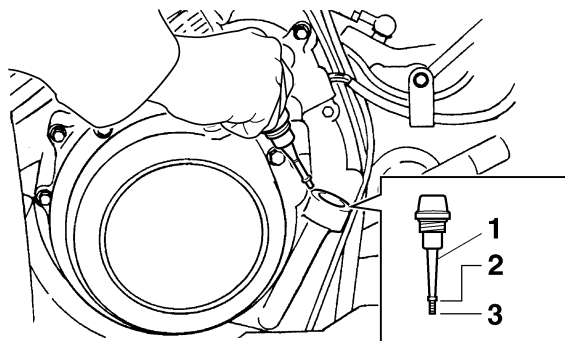

1. Dipstick
2. Maximum level mark
3. Minimum level mark

**NOTE:** \_\_\_\_\_

The engine oil should be between the minimum and maximum level marks.

5. If the engine oil is at or below the minimum level mark, add sufficient oil of the recommended type to raise it to the correct level.
6. Insert the dipstick into the oil filler hole, and then tighten the engine oil filler cap.

## To change the engine oil (with or without oil filter cartridge replacement)

1. Place the ATV on a level surface.
2. Start the engine, warm it up for several minutes, and then turn it off.
3. Place an oil pan under the engine to collect the used oil.
4. Remove the engine oil filler cap, and then remove the engine oil drain bolt to drain the oil from the crankcase.

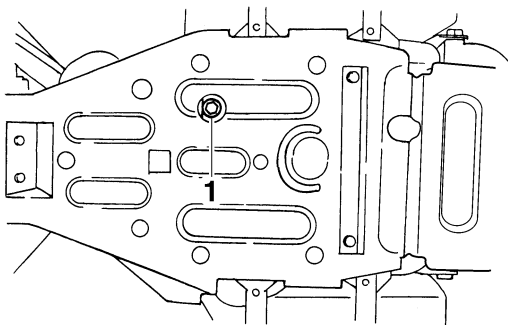

1. Engine oil drain bolt

### NOTE:

Skip steps 5–7 if the oil filter cartridge is not being replaced.

5. Remove the oil filter cartridge with an oil filter wrench.

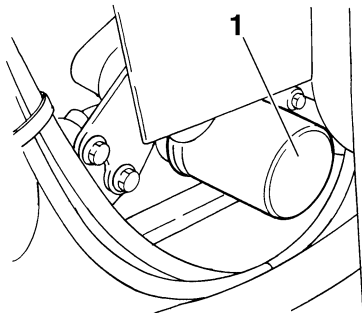

1. Oil filter cartridge

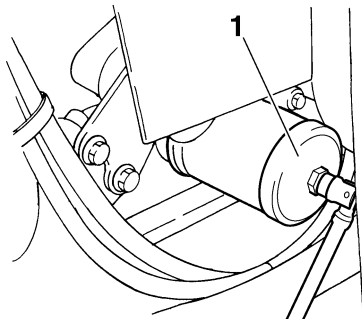

1. Oil filter wrench

**NOTE:** \_\_\_\_\_  
An oil filter wrench is available at a nearby Yamaha dealer.

6. Apply a thin coat of engine oil to the O-ring of the new oil filter cartridge.

**NOTE:** \_\_\_\_\_  
Make sure that the O-ring is properly seated.

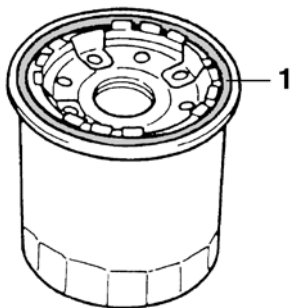

1. O-ring

7. Install the new oil filter cartridge with an oil filter wrench, and then tighten it to the specified torque with a torque wrench.

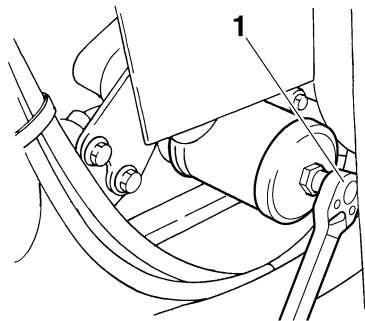

1. Torque wrench

Tightening torque:  
Oil filter cartridge:  
17 Nm (1.7 m-kgf, 12 ft-lbf)

8. Install the engine oil drain bolt, and then tighten it to the specified torque.

Tightening torque:  
Engine oil drain bolt:  
23 Nm (2.3 m-kgf, 17 ft-lbf)

9. Add the specified amount of the recommended engine oil, and then install and tighten the engine oil filler cap.

Recommended oil:

See page 10-1.

Oil quantity:

Without oil filter cartridge replacement:

2.20 L (2.33 US qt) (1.94 Imp.qt)

With oil filter cartridge replacement:

2.30 L (2.43 US qt) (2.02 Imp.qt)

EBU28570

## Final gear oil

The final gear case must be checked for oil leakage before each ride. If any leakage is found, have a Yamaha dealer check and repair the ATV. In addition, the final gear oil level must be checked and the oil changed as follows at the intervals specified in the periodic maintenance and lubrication chart.

### To check the final gear oil level

1. Place the ATV on a level surface.

### NOTE:

The final gear oil level must be checked on a cold engine.

2. Remove the final gear oil filler bolt, and then check the oil level in the final gear case.

### NOTE:

The oil level should be at the brim of the filler hole.

ECB00300

### CAUTION:

- In order to prevent clutch slippage (since the engine oil also lubricates the clutch), do not mix any chemical additives. Do not use oils with a diesel specification of “CD” or oils of a higher quality than specified. In addition, do not use oils labeled “ENERGY CONSERVING II” or higher.

- Make sure that no foreign material enters the crankcase.

10. Start the engine, and then let it idle for several minutes while checking it for oil leakage. If oil is leaking, immediately turn the engine off and check for the cause.
11. Turn the engine off, wait at least ten minutes, and then check the oil level and correct it if necessary.



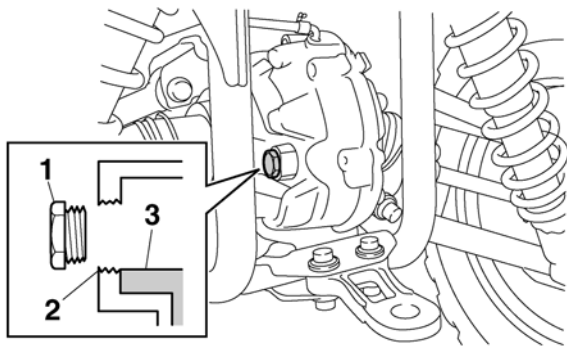

1. Final gear oil filler bolt
2. Correct oil level
3. Final gear oil

3. If the oil is below the brim of the filler hole, add sufficient oil of the recommended type to raise it to the correct level.
4. Install the oil filler bolt, and then tighten it to the specified torque.

Tightening torque:

Final gear oil filler bolt:

23 Nm (2.3 m·kgf, 17 ft·lbf)

## To change the final gear oil

1. Remove the engine guard and the final gear case guard by removing the bolts.

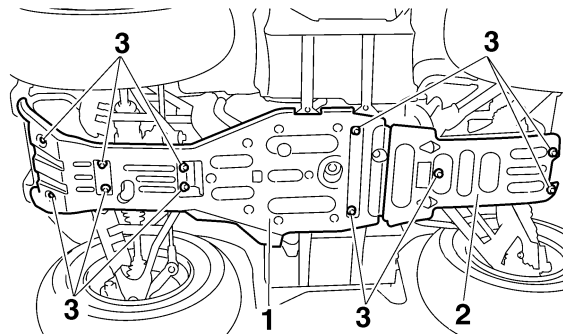

1. Engine guard
2. Final gear case guard
3. Bolt

2. Place the ATV on a level surface.
3. Place an oil pan under the final gear case to collect the used oil.
4. Remove the final gear oil filler bolt and the final gear oil drain bolt to drain the oil from the final gear case.

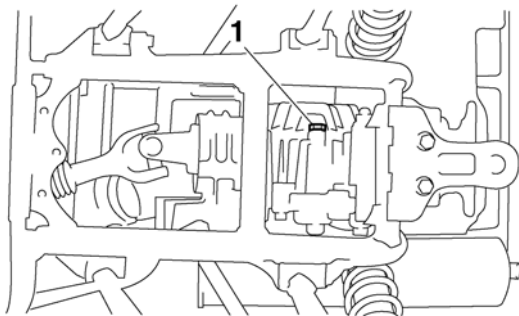

1. Final gear oil drain bolt

5. Install the drain bolt, and then tighten it to the specified torque.

8

Tightening torque:

Final gear oil drain bolt:

23 Nm (2.3 m·kgf, 17 ft·lbf)

6. Add the recommended final gear oil to the brim of the filler hole as shown.

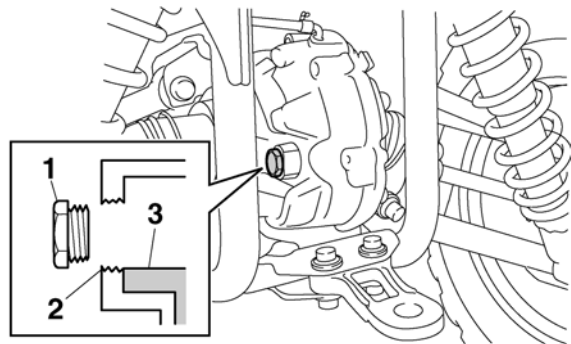

1. Final gear oil filler bolt

2. Correct oil level

3. Final gear oil

Recommended final gear oil:

See page 10-1.

**NOTE:**

\_\_\_\_\_

If the recommended oil is not available, SAE80W-90 API GL-5 Hypoid gear oil may be used instead. However, when using this oil, noise from the final gear case may occur when applying the rear brake.

\_\_\_\_\_

**CAUTION:**

**Be sure no foreign material enters the final gear case.**

7. Install the oil filler bolt, and then tighten it to the specified torque.

Tightening torque:

Final gear oil filler bolt:

23 Nm (2.3 m·kgf, 17 ft·lbf)

8. Check the final gear case for oil leakage. If oil is leaking, check for the cause.
9. Install the engine guard and the final gear case guard by installing the bolts, and then tightening them to the specified torques.

Tightening torques:

Engine guard bolt:

7 Nm (0.7 m·kgf, 5.1 ft·lbf)

Final gear case guard bolt:

7 Nm (0.7 m·kgf, 5.1 ft·lbf)

**Differential gear oil**

The differential gear case must be checked for oil leakage before each ride. If any leakage is found, have a Yamaha dealer check and repair the ATV. In addition, the differential gear oil level must be checked and the oil changed as follows at the intervals specified in the periodic maintenance and lubrication chart.

**To check the differential gear oil level**

1. Place the ATV on a level surface.

**NOTE:**

The differential gear oil level must be checked on a cold engine.

2. Remove the differential gear oil filler bolt, and then check the oil level in the differential gear case.

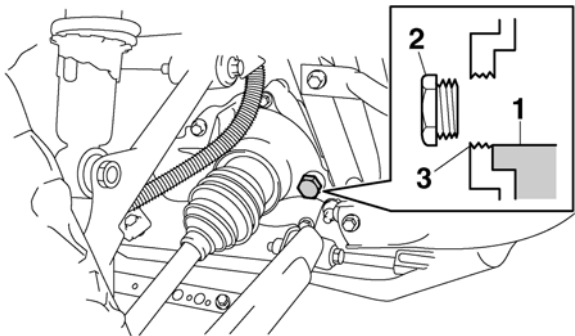

1. Differential gear oil
2. Differential gear oil filler bolt
3. Correct oil level

8

#### NOTE:

The oil level should be at the brim of the filler hole.

3. If the oil is below the brim of the filler hole, add sufficient oil of the recommended type to raise it to the correct level.
4. Install the oil filler bolt, and then tighten it to the specified torque.

Tightening torque:

Differential gear oil filler bolt:  
23 Nm (2.3 m·kgf, 17 ft·lbf)

#### To change the differential gear oil

1. Place the ATV on a level surface.
2. Place an oil pan under the differential gear case to collect the used oil.
3. Remove the differential gear oil filler bolt and the differential gear oil drain bolt to drain the oil from the differential gear case.

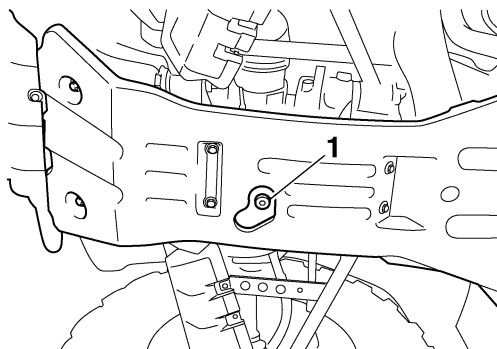

1. Differential gear oil drain bolt

4. Install the drain bolt, and then tighten it to the specified torque.

Tightening torque:

Differential gear oil drain bolt:  
10 Nm (1.0 m·kgf, 7.2 ft·lbf)

5. Add the recommended differential gear oil to the brim of the filler hole as shown.

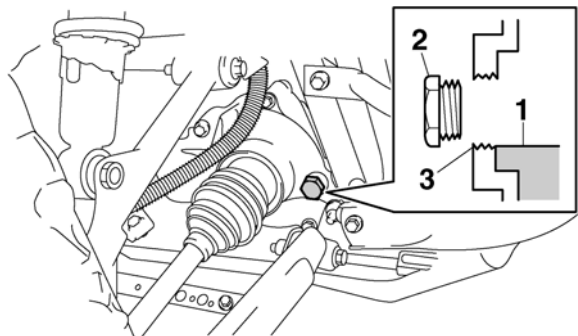

1. Differential gear oil
2. Differential gear oil filler bolt
3. Correct oil level

Recommended differential gear oil:  
See page 10-1.

ECB00410

**CAUTION:**

**Be sure no foreign material enters the differential gear case.**

6. Install the oil filler bolt, and then tighten it to the specified torque.

Tightening torque:

Differential gear oil filler bolt:  
23 Nm (2.3 m·kgf, 17 ft·lbf)

7. Check the differential gear case for oil leakage. If oil is leaking, check for the cause.

EBU23640

### Cleaning the air filter element

The air filter element should be cleaned at the intervals specified in the periodic maintenance and lubrication chart. Clean the air filter element more frequently if you are riding in unusually wet or dusty areas.

**NOTE:** \_\_\_\_\_

There is a check hose at the bottom of the air filter case. If dust or water collects in this hose, empty the hose and clean the air filter element and air filter case.

\_\_\_\_\_

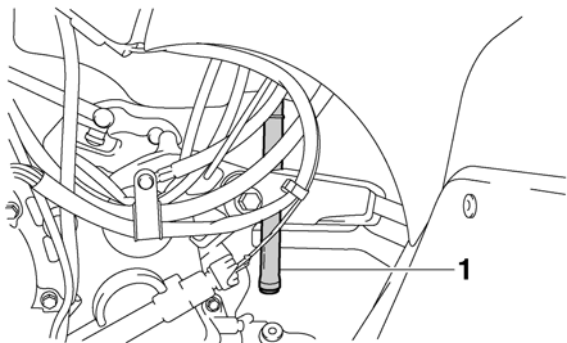

1. Air filter case check hose

1. Remove the seat. (See page 4-17.)
2. Remove the air filter case cover by unhooking the holders.

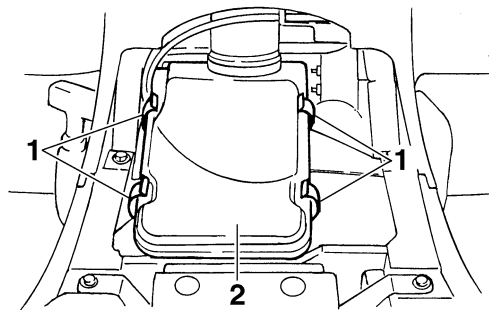

1. Air filter case cover holder

2. Air filter case cover

3. Pull the air filter element out of the air filter case.

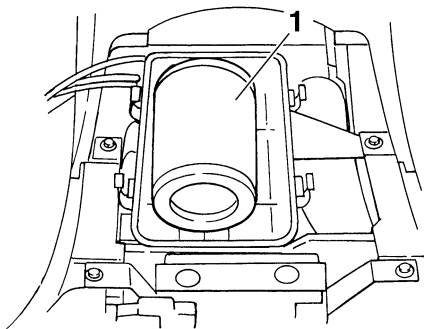

1. Air filter element

4. Pull off the lock plate, and then remove the sponge material from the air filter element frame.

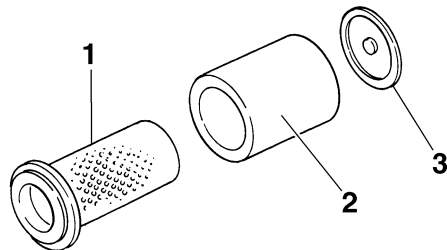

1. Air filter element frame
2. Sponge material
3. Air filter element lock plate

5. Wash the sponge material gently but thoroughly in solvent.

EWB01940



**Always use parts cleaning solvent to clean the sponge material. Never use low-flash-point solvents or gasoline to clean the sponge material because the engine could catch fire or explode.**

6. Squeeze the excess solvent out of the sponge material and let it dry.

**CAUTION:** \_\_\_\_\_

**Do not twist the sponge material when squeezing it.**

7. Check the sponge material and replace it if damaged.
8. Apply a quality foam air filter oil to the sponge material.

**NOTE:** \_\_\_\_\_

The sponge material should be wet but not dripping.

9. Pull the sponge material over the air filter element frame, and then install the lock plate.
10. Insert the air filter element into the air filter case, and then install the air filter case cover by hooking the holders onto the air filter case.
11. Install the seat.

**NOTE:** \_\_\_\_\_

The air filter element should be cleaned every 20–40 hours. It should be cleaned and lubricated more often if the ATV is operated in extremely dusty areas. Each time the air filter element maintenance is performed, check the air inlet of the air filter case for obstructions. Check the air filter case rubber joint to the carburetor fittings and the rubber joint

manifold fittings for an air-tight seal. Tighten all fittings securely to avoid the possibility of unfiltered air entering the engine.

**CAUTION:** \_\_\_\_\_

- **Make sure that the air filter element is properly seated in the air filter case.**
- **Never operate the engine with the air filter element removed. This will allow unfiltered air to enter the engine, causing rapid engine wear and possible engine damage. Additionally, operation without the air filter element will affect carburetor jetting with subsequent poor performance and possible engine overheating.**

**Cleaning the spark arrester**

Be sure the exhaust pipe and muffler are cool before cleaning the spark arrester.

1. Remove the bolts.



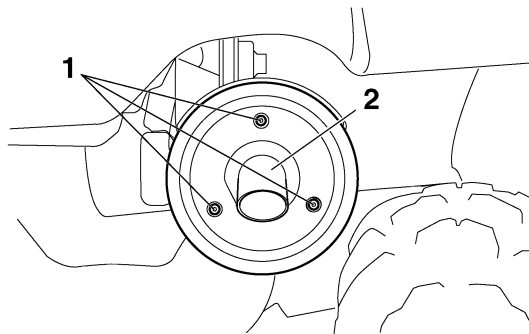

- 1. Bolt
- 2. Tailpipe

- 2. Remove the tailpipe by pulling it out of the muffler.
- 3. Tap the tailpipe lightly, and then use a wire brush to remove any carbon deposits from the spark arrester portion of the tailpipe and inside of the tailpipe housing.

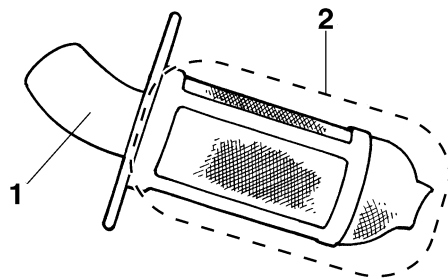

- 1. Tailpipe
- 2. Spark arrester

- 4. Insert the tailpipe into the muffler and align the bolt holes.
- 5. Install and tighten the bolts.

EWB02340



**WARNING**

**Do not start the engine when cleaning the spark arrester, otherwise it could cause injury to the eyes, burns, carbon monoxide poisoning, possibly leading to death, and start a fire. Always let the exhaust system cool prior to touching exhaust components.**

EBU23920

## V-belt cooling duct check hose

If dust or water collects in the V-belt cooling duct check hose, remove the hose and clean it.

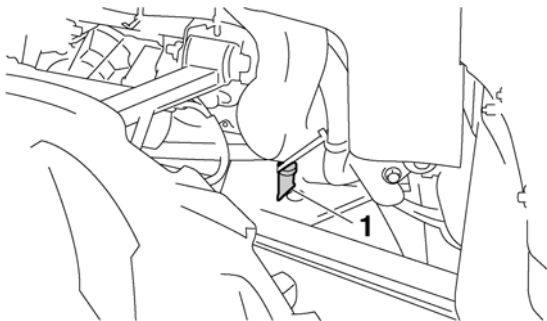

1. V-belt cooling duct check hose (left front side of ATV)

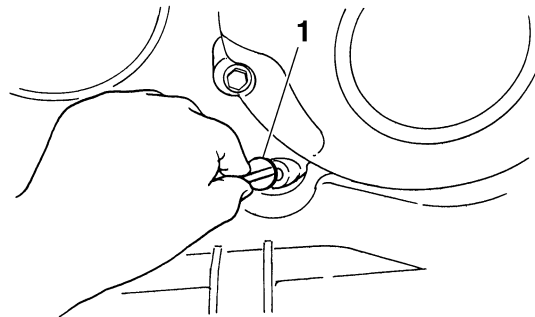

1. V-belt case drain plug

EBU23940

## Adjusting the carburetor

The carburetor should be checked and, if necessary, adjusted at the intervals specified in the periodic maintenance and lubrication chart. The carburetor is an important part of the engine and requires very sophisticated adjustment. Therefore, most carburetor adjustments should be left to a Yamaha dealer, who has the necessary professional knowledge and experience. The adjustment described in the following section, however, may be performed by the owner as part of routine maintenance.

8

EBU23930

## V-belt case drain plug

After riding in water deep enough to allow it to enter the V-belt case, remove this plug to drain the water from the case.

### NOTE:

If water drains from the V-belt case after removing the plug, have a Yamaha dealer check the ATV as the water may affect other engine parts.

**CAUTION:** \_\_\_\_\_

The carburetor has been set and extensively tested at the Yamaha factory. Changing these settings without sufficient technical knowledge may result in poor performance or damage to the engine.

**Adjusting the engine idling speed**

The engine idling speed must be checked and, if necessary, adjusted as follows at the intervals specified in the periodic maintenance and lubrication chart.

**NOTE:** \_\_\_\_\_

A diagnostic tachometer is needed to make this adjustment.

1. Start the engine and warm it up.

**NOTE:** \_\_\_\_\_

The engine is warm when it quickly responds to the throttle.

2. Attach the tachometer to the spark plug lead.
3. Check the engine idling speed and, if necessary, adjust it to specification by turning the throttle stop screw at the carburetor. To in-

crease the engine idling speed, turn the throttle stop screw in direction (a), and to decrease it, turn the screw in direction (b).

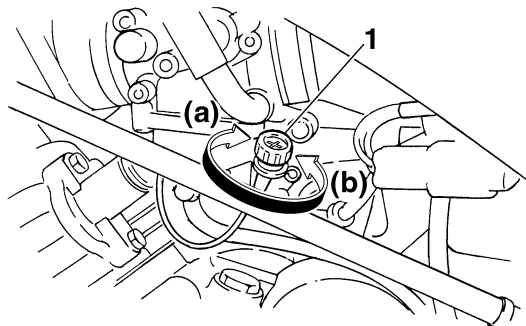

1. Throttle stop screw

<p>Engine idling speed: 1450–1550 r/min</p>
---

**NOTE:** \_\_\_\_\_

If the specified idling speed cannot be obtained as described above, have a Yamaha dealer make the adjustment.

## Adjusting the throttle cable free play

The throttle cable free play should be checked and, if necessary, adjusted at the intervals specified in the periodic maintenance and lubrication chart.

The throttle cable free play should measure 3.0–5.0 mm (0.12–0.20 in) at the throttle lever. Periodically check the throttle cable free play and, if necessary, adjust it as follows.

### NOTE:

The engine idling speed must be checked, and adjusted if necessary, before adjusting the throttle cable free play.

8

1. Loosen the locknut.
2. To increase the throttle cable free play, turn the adjusting bolt in direction (a). To decrease the throttle cable free play, turn the adjusting bolt in direction (b).

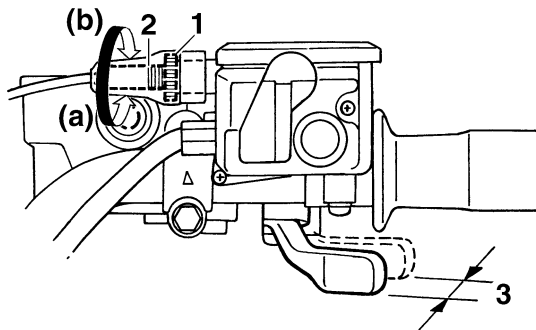

1. Locknut
2. Throttle cable free play adjusting bolt
3. Throttle cable free play

3. Tighten the locknut.

## Valve clearance

The valve clearance changes with use, resulting in improper air-fuel mixture and/or engine noise. To prevent this from occurring, the valve clearance must be adjusted by a Yamaha dealer at the intervals specified in the periodic maintenance and lubrication chart.

## Adjusting the drive select lever safety system cable

The drive select lever safety system cable stretches with use, which can result in improper function. Therefore, the safety system cable should be checked and adjusted at the intervals specified in the periodic maintenance and lubrication chart.

## Checking the front brake pads and rear brake friction plates

The front brake pads and the rear brake friction plates must be checked for wear at the intervals specified in the periodic maintenance and lubrication chart.

### NOTE:

This ATV is equipped with a wet, multiple-disc type rear brake, which is located inside of the final gear case.

## Front brake pads

Check each front brake pad for damage and measure the lining thickness. If a brake pad is damaged or if the lining thickness is less than 1.0 mm (0.04 in), have a Yamaha dealer replace the brake pads as a set.

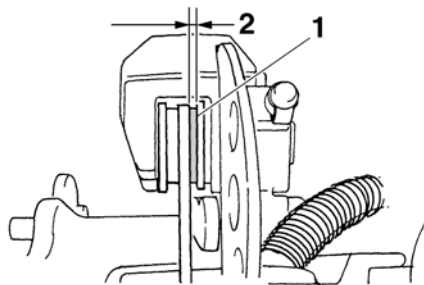

1. Brake pad
2. Lining thickness

### NOTE:

The wheels need to be removed to check the brake pads. (See page 8-44.)

## Rear brake friction plates

The rear brake is provided with a wear indicator, which allows you to check the brake friction plate wear without having to disassemble the brake. To check the brake friction plate wear, check the position of the wear indicator while applying the brake. If a brake friction plate has worn to the point that the wear indicator reaches the wear limit mark, have a Yamaha dealer replace the brake friction plates as a set.

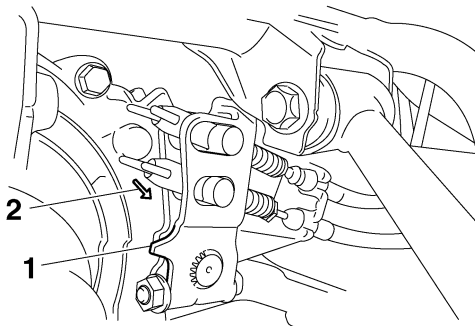

1. Wear indicator
2. Wear limit mark

## Checking the brake fluid level

Insufficient brake fluid may allow air to enter the brake system, possibly causing it to become ineffective.

Before riding, check that the brake fluid is above the minimum level mark and replenish if necessary. A low brake fluid level may indicate worn brake pads and/or brake system leakage. If the brake fluid level is low, be sure to check the brake pads for wear and the brake system for leakage.

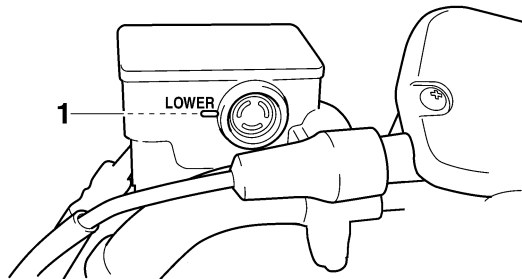

1. Minimum level mark

Observe these precautions:

- When checking the fluid level, make sure that the top of the brake fluid reservoir is level.

- Use only the recommended quality brake fluid, otherwise the rubber seals may deteriorate, causing leakage and poor braking performance.

Recommended brake fluid:  
DOT 4

- Refill with the same type of brake fluid. Mixing fluids may result in a harmful chemical reaction and lead to poor braking performance.
- Be careful that water does not enter the brake fluid reservoir when refilling. Water will significantly lower the boiling point of the fluid and may result in vapor lock.
- Brake fluid may deteriorate painted surfaces or plastic parts. Always clean up spilled fluid immediately.
- As the brake pads wear, it is normal for the brake fluid level to gradually go down. However, if the brake fluid level goes down suddenly, have a Yamaha dealer check the cause.

EBU24280

## Changing the brake fluid

Have a Yamaha dealer change the brake fluid at the intervals specified in the NOTE after the periodic maintenance and lubrication chart. In addition,

have the oil seals of the brake master cylinder and calipers as well as the brake hoses replaced at the intervals listed below or whenever they are damaged or leaking.

- Oil seals: Replace every two years.
- Brake hoses: Replace every four years.

EBU24390

## Checking the front brake lever free play

The brake lever free play must be checked at the intervals specified in the periodic maintenance and lubrication chart. The brake lever should have a free play of zero mm (zero in) as shown. If the free play is incorrect, have a Yamaha dealer check the brake system.

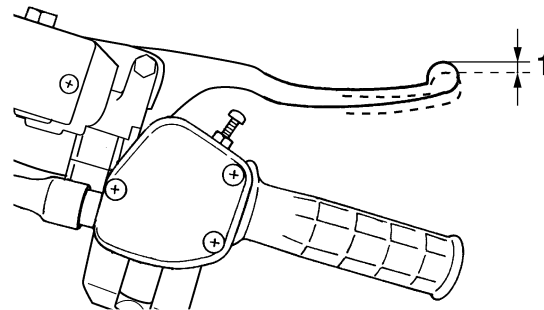

1. Brake lever free play



**Operating with improperly serviced or adjusted brakes could cause loss of braking ability, which could lead to an accident.**

**After servicing:**

- **Make sure the brakes operate smoothly and that the free play is correct.**
- **Make sure the brakes do not drag.**
- **Make sure the brakes are not spongy. All air must be bled from the brake system.**

**Replacement of brake components requires professional knowledge. These procedures should be performed by a Yamaha dealer.**

## **Adjusting the brake pedal and rear brake lever free play and checking the brake pedal position**

The brake pedal and brake lever free play and the brake pedal position must be checked and, if necessary, adjusted at the intervals specified in the periodic maintenance and lubrication chart.

### **NOTE:** \_\_\_\_\_

- Always perform this maintenance completely in the following order whenever adjusting the rear brake.
- When adjusting the rear brake, be sure to adjust both the brake pedal and the brake lever.
- Before adjusting the brake lever and brake pedal free play, check the rear brake friction plates for wear.

### **Adjusting the brake pedal and brake lever free play**

The brake pedal free play should measure 17.0–20.0 mm (0.67–0.79 in). The brake lever free play should measure 8.0–10.5 mm (0.31–0.41 in). If either free play is incorrect, adjust it as follows.



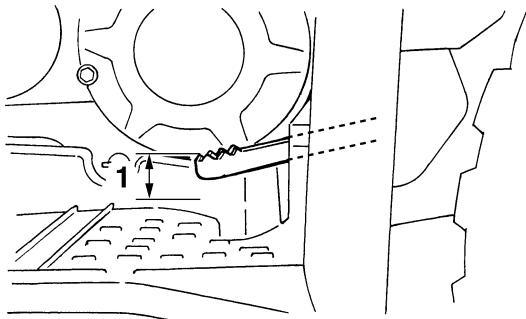

1. Brake pedal free play

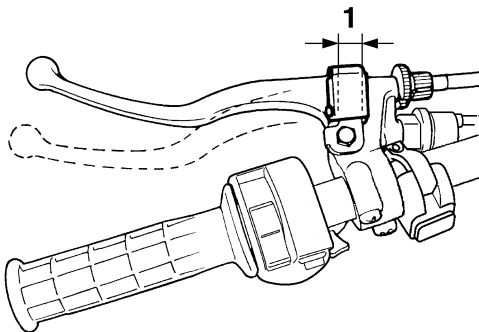

1. Brake lever free play

1. Loosen the locknut at the brake lever and fully turn in the brake lever free play adjusting bolt.

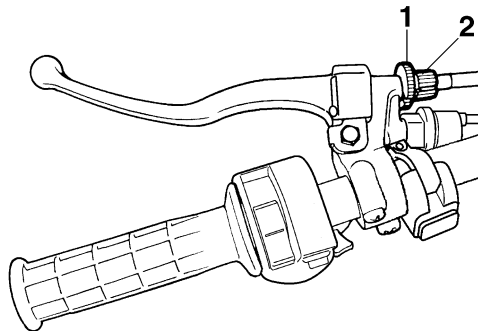

1. Locknut
2. Brake lever free play adjusting bolt

2. Fully loosen the brake lever free play adjusting nut on the brake cable at the final gear case.

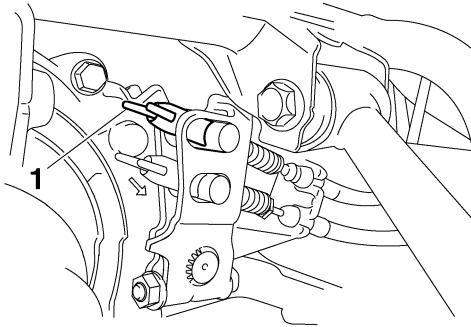

1. Brake lever free play adjusting nut

3. Push the brake camshaft lever in direction (a) until it stops [apply approximately 47 N (10.6 lbf) (4.8 kgf) of force], and then turn the brake pedal free play adjusting nut on the brake cable at the final gear case so that gap "A" measures 2.5–3.0 mm (0.10–0.12 in).

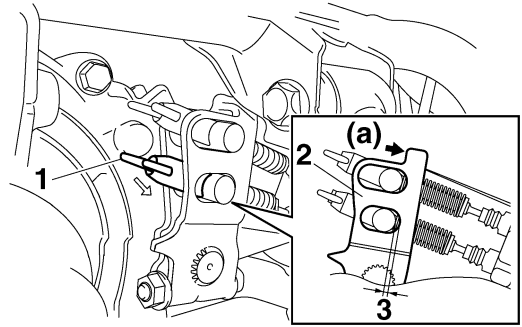

1. Brake pedal free play adjusting nut

2. Brake camshaft lever

3. Gap "A"

4. Push the brake camshaft lever in direction (a) until it stops [apply approximately 47 N (10.6 lbf) (4.8 kgf) of force], and then turn the brake lever free play adjusting nut on the brake cable at the final gear case so that gap "B" measures 4.0–6.0 mm (0.16–0.24 in).

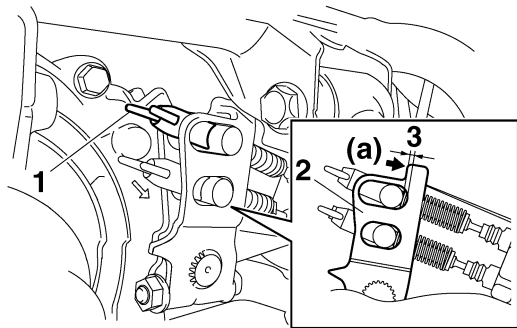

1. Brake lever free play adjusting nut
2. Brake camshaft lever
3. Gap "B"

5. Check the brake lever free play and, if necessary, adjust it by turning the brake lever free play adjusting bolt at the brake lever. Turn the brake lever free play adjusting bolt in direction (a) to increase the free play, and in direction (b) to decrease it.

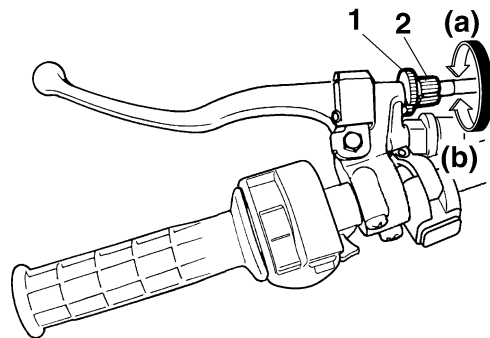

1. Locknut
2. Brake lever free play adjusting bolt

6. Tighten the locknut at the brake lever.

**NOTE:** \_\_\_\_\_

When adjusting the rear brake lever free play:

- Be sure not to step on the brake pedal.
- Make sure the brake pedal does not move.

**Checking the brake pedal position**

The top of the brake pedal should be positioned 75.0–85.0 mm (2.95–3.35 in) above the footboard. If the brake pedal position is incorrect, have a Yamaha dealer adjust it.

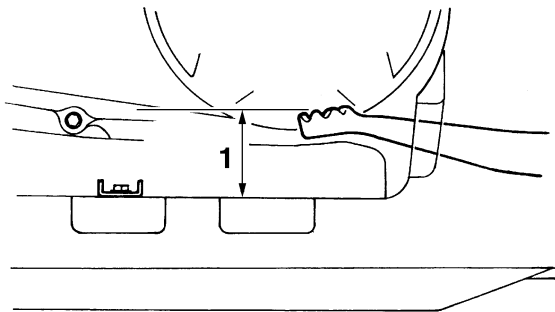

1. Distance between brake pedal and footboard

EWB02080

**⚠ WARNING**

**8**

**Operating with improperly serviced or adjusted brakes could cause loss of braking ability, which could lead to an accident.**

**After servicing:**

- **Make sure the brakes operate smoothly and that the free play is correct.**
- **Make sure the brakes do not drag.**

**Replacement of brake components requires professional knowledge. These procedures should be performed by a Yamaha dealer.**

EBU24230

**Axle boots**

The axle boots must be checked for damage at the intervals specified in the periodic maintenance and lubrication chart. Check the axle boots for tears or damage. If any damage is found, have them replaced by a Yamaha dealer.

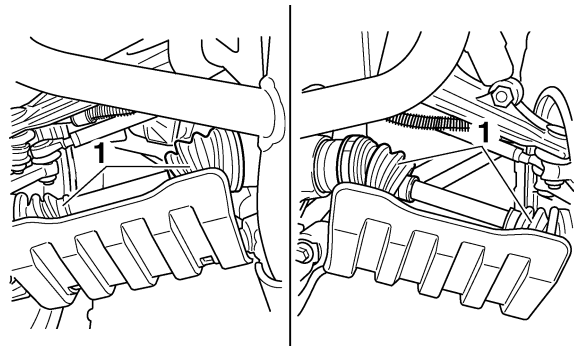

1. Front axle boot (each side)

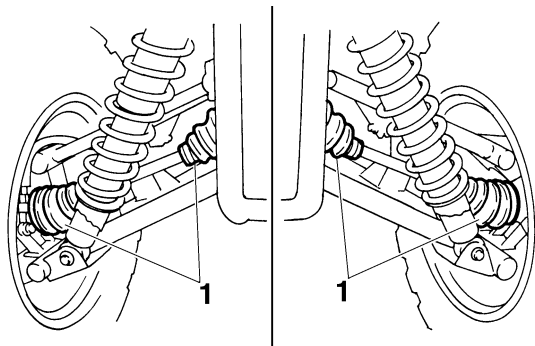

1. Rear axle boot (each side)

EBU24751

## Brake light switches

The operation of the brake light switches must be checked and, if necessary, adjusted at the intervals specified in the periodic maintenance and lubrication chart.

The brake light switch for the brake pedal can be adjusted as follows, but the other brake light switches should be adjusted by a Yamaha dealer.

1. Remove panel A. (See page 8-8.)

**NOTE:** \_\_\_\_\_  
 The brake light switch is properly adjusted when the brake light comes on just before braking takes effect.

2. Turn the adjusting nut while holding the brake light switch in place. To make the brake light come on earlier, turn the adjusting nut in direction (a). To make the brake light come on later, turn the adjusting nut in direction (b).

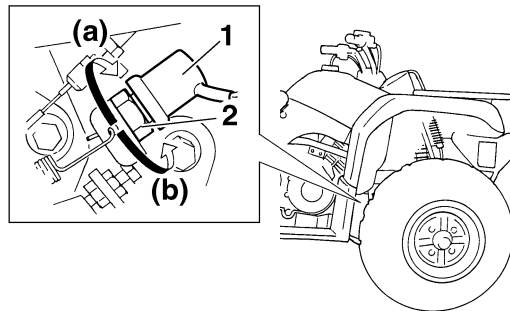

1. Brake light switch
2. Brake light switch adjusting nut
3. Install the panel.

EBU24900

## Checking and lubricating the cables

The operation and the condition of all control cables should be checked before each ride, and the cables and cable ends should be lubricated if necessary. If a cable is damaged or does not move smoothly, have a Yamaha dealer check or replace it.

Recommended lubricant:  
Engine oil

EWB02130



**WARNING**

**Inspect cables frequently and replace if damaged. Corrosion can result when the cable sheaths become damaged, and cables can also become frayed or kinked, which could restrict the operation of controls and lead to an accident or injury.**

8

EBU24911

## Checking and lubricating the front and rear brake levers

The operation of the front and rear brake levers should be checked before each ride, and the lever pivots should be lubricated if necessary.

Recommended lubricant:

Lithium-soap-based grease (all-purpose grease)

### Front brake lever

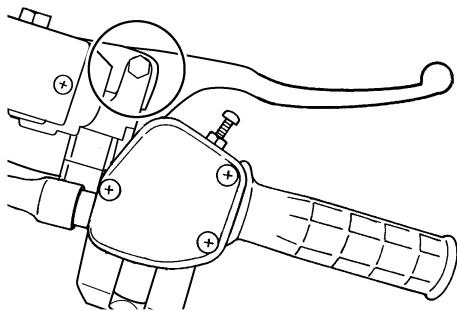

## Rear brake lever

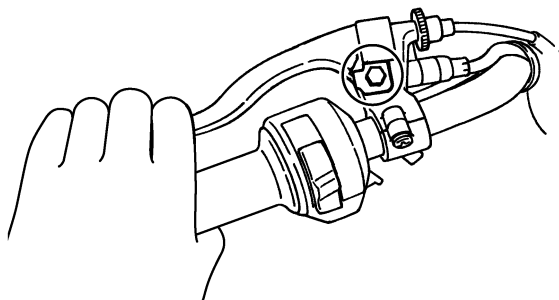

EBU24950

### Checking and lubricating the brake pedal

The operation of the brake pedal should be checked before each ride, and the pedal pivot should be lubricated if necessary.

#### NOTE:

To access the brake pedal pivot, remove panel A. (See page 8-8.)

Recommended lubricant:  
Lithium-soap-based grease (all-purpose grease)

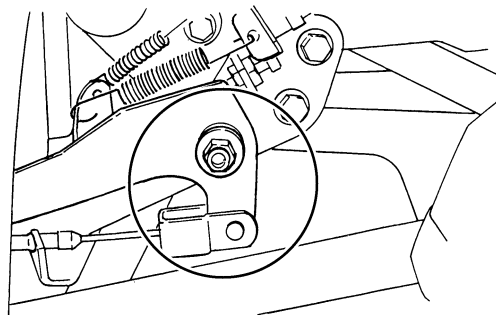

EBU24961

### Checking the wheel bearings

The front and rear wheel bearings must be checked at the intervals specified in the periodic maintenance and lubrication chart. If there is play in a wheel hub or if a wheel does not turn smoothly, have a Yamaha dealer check the wheel bearings.

EBU24970

### Lubricating the drive shaft universal joint

The drive shaft universal joint must be lubricated at the intervals specified in the periodic maintenance and lubrication chart.

Lubricate the universal joint using a grease gun.

Recommended lubricant:  
Lithium-soap-based grease

EBU25021

### Checking the stabilizer bushes

The stabilizer bushes must be checked for cracks or damage at the intervals specified in the periodic maintenance and lubrication chart.

Have a Yamaha dealer replace the stabilizer bushes if necessary.

EBU25050

### Lubricating the knuckle pivots

The knuckle pivots must be lubricated at the intervals specified in the periodic maintenance and lubrication chart.

Lubricate the pivoting points using a grease gun.

Recommended lubricant:  
Lithium-soap-based grease

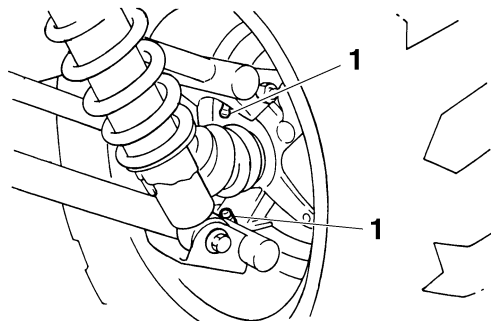

1. Grease nipple

EBU25100

### Lubricating the steering shaft

The steering shaft must be lubricated at the intervals specified in the periodic maintenance and lubrication chart.

Recommended lubricant:  
Lithium-soap-based grease



## Battery

This model is equipped with a sealed-type (MF) battery, which does not require any maintenance. There is no need to check the electrolyte or to add distilled water. Check and, if necessary, tighten the battery lead connections.

ECB00620

### CAUTION:

**Never attempt to remove the battery cell seals, as this would permanently damage the battery.**

EWB02160

### WARNING

**Battery electrolyte is poisonous and dangerous, as it contains sulfuric acid, which can cause severe burns. Avoid contact with skin, eyes or clothing. Always shield your eyes when working near batteries.**

**Antidote:**

**EXTERNAL: Flush with water.**

**INTERNAL: Drink large quantities of water or milk. Follow with milk of magnesia, beaten egg or vegetable oil. Call a physician immediately.**

**EYES: Flush with water for 15 minutes and get prompt medical attention.**

**Batteries produce explosive gases. Keep sparks, flame, cigarettes or other sources of ignition away. Ventilate when charging or using in an enclosed space.**

**KEEP OUT OF REACH OF CHILDREN.**

### To charge the battery

Have a Yamaha dealer charge the battery as soon as possible if it seems to have discharged. Keep in mind that the battery tends to discharge more quickly if the ATV is equipped with optional electrical accessories.

### To store the battery

1. If the ATV will not be used for more than one month, remove the battery, fully charge it, and then place it in a cool, dry place.
2. If the battery will be stored for more than two months, check it at least once a month and fully charge it if necessary.

### To install the battery

#### NOTE:

Be sure the battery is fully charged.

1. Place the battery in its compartment.

2. Make sure to properly connect the battery leads to the battery terminals.

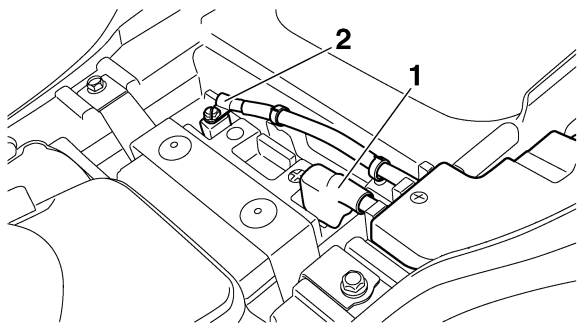

1. Positive battery terminal
2. Negative battery terminal

8

ECB00630

**CAUTION:**

- Always keep the battery charged. Storing a discharged battery can cause permanent battery damage.
- To charge a sealed-type (MF) battery, a special constant-voltage battery charger is required. Using a conventional battery charger will damage the battery. If you do not have

access to a constant-voltage battery charger, have a Yamaha dealer charge your battery.

EBU25323

## Replacing a fuse

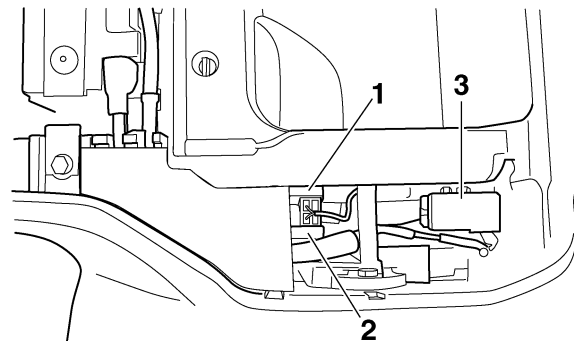

1. Main fuse
2. Spare main fuse
3. Fuse box

**CAUTION:**

**To prevent accidental short-circuiting, turn off the main switch when checking or replacing a fuse.**

2. Remove the blown fuse, and then install a new fuse of the specified amperage.

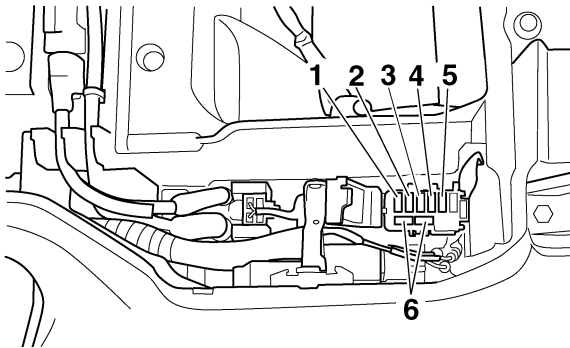

1. Headlight fuse
2. Ignition fuse
3. Auxiliary DC jack fuse (for optional auxiliary DC jack)
4. Four-wheel-drive motor fuse
5. Signaling system fuse
6. Spare fuse

The main fuse and the fuse box are located under the seat. (See page 4-17.)

If a fuse is blown, replace it as follows.

1. Turn the key to "OFF" and turn off all electrical circuits.

## Specified fuses:

Main fuse:

30.0 A

Headlight fuse:

15.0 A

Ignition fuse:

15.0 A

Four-wheel-drive motor fuse:

10.0 A

Signaling system fuse:

10.0 A

Auxiliary DC jack fuse:

10.0 A

**⚠ WARNING**

Always use a fuse of the specified rating, and never use a substitute object in place of the proper fuse. An improper fuse or a substitute object can cause damage to the electrical system, which could lead to a fire.

3. Turn the key to "ON" and turn on the electrical circuits to check if the devices operate.
4. If the fuse immediately blows again, have a Yamaha dealer check the electrical system.

**Replacing a headlight bulb**

If a headlight bulb burns out, replace it as follows.

**8**

1. Remove the cover at the rear of the headlight by pulling it off.

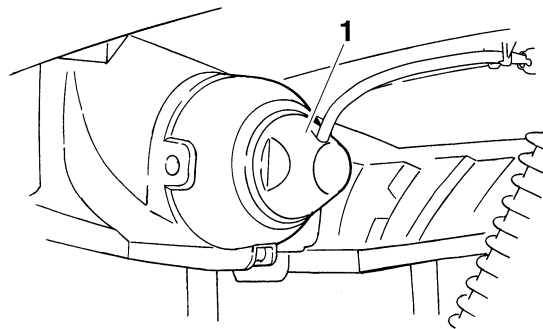

1. Cover at the rear of the headlight

2. Remove the headlight bulb holder cover by pulling it off.

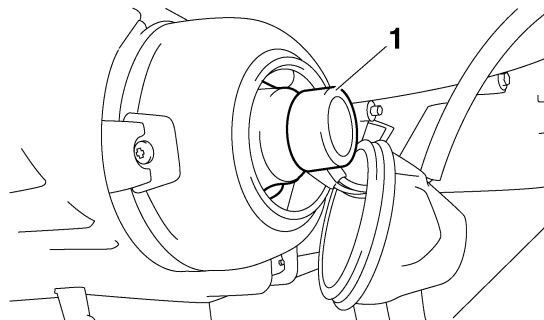

1. Headlight bulb holder cover

3. Remove the headlight bulb holder by pushing it in and turning it counterclockwise.

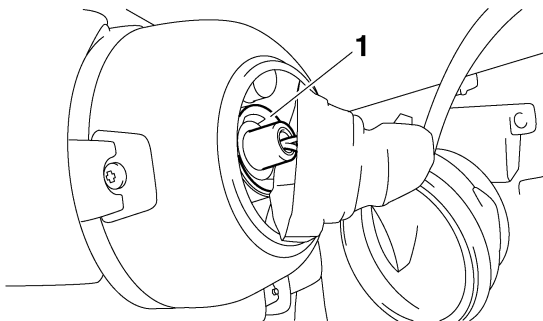

1. Headlight bulb holder

4. Remove the defective bulb by pulling it out.

EWB02220

**WARNING**

**A headlight bulb is hot when it is on and immediately after it is turned off. Wait for the bulb to cool before touching or removing it. You can be burned or a fire could start if the bulb touches something flammable.**

5. Insert a new headlight bulb into the bulb holder by pushing it in.

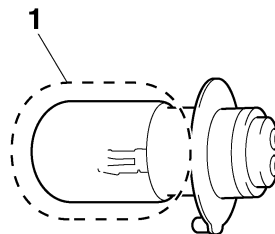

1. Do not touch the glass part of the bulb.

ECB00650

**CAUTION:**

**Do not touch the glass part of the headlight bulb to keep it free from oil, otherwise the transparency of the glass, the luminosity of the bulb, and the bulb life will be adversely affected. Thoroughly clean off any dirt and fingerprints on the headlight bulb using a cloth moistened with alcohol or thinner.**

6. Install the bulb holder by pushing it in and turning it clockwise.
7. Install the bulb holder cover and the cover at the rear of the headlight.

**CAUTION:**

Make sure the headlight bulb holder cover is securely fitted over the bulb holder and seated properly.

- Adjust the headlight beam if necessary.

**Adjusting a headlight beam****CAUTION:**

It is advisable to have a Yamaha dealer make this adjustment.

To raise a headlight beam, turn the adjusting screw in direction (a).

To lower a headlight beam, turn the adjusting screw in direction (b).

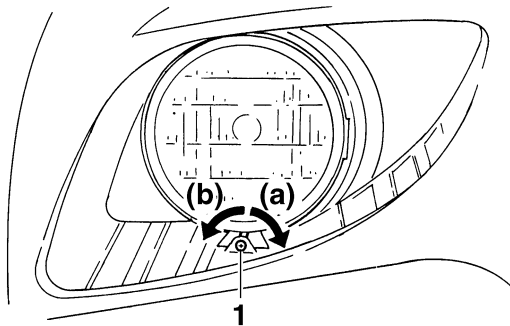

- Headlight beam adjusting screw

**Replacing the tail/brake light bulb**

If the tail/brake light bulb burns out, have a Yamaha dealer replace it.

**Removing a wheel**

- Loosen the wheel nuts.

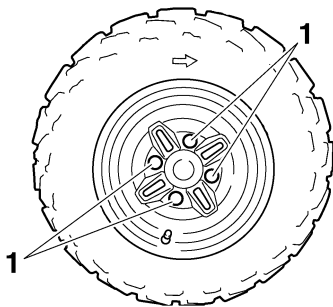

1. Wheel nut

2. Elevate the ATV and place a suitable stand under the frame.
3. Remove the nuts from the wheel.
4. Remove the wheel.

EBU25700

## Installing a wheel

1. Install the wheel and the nuts.

### NOTE:

- The arrow mark ⇨ on the tire must point toward the rotating direction of the wheel.

- Tapered nuts are used for both the front and rear wheels. Install the nuts with their tapered side towards the wheel.
- 

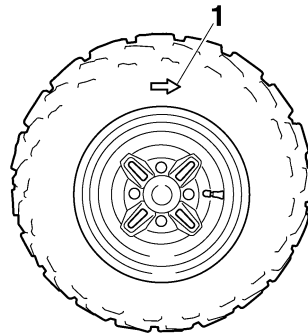

1. Arrow mark

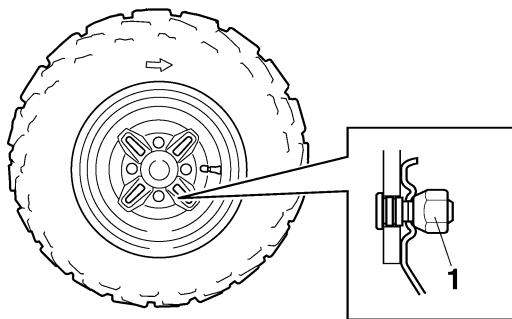

1. Tapered nut
2. Lower the ATV to the ground.
3. Tighten the wheel nuts to the specified torques.

8

#### Tightening torques:

Front wheel nut:

55 Nm (5.5 m·kgf, 40 ft·lbf)

Rear wheel nut:

55 Nm (5.5 m·kgf, 40 ft·lbf)

EBU25720

## Troubleshooting

Although Yamaha ATVs receive a thorough inspection before shipment from the factory, trouble may occur during operation. Any problem in the fuel, compression, or ignition systems, for example, can cause poor starting and loss of power.

The following troubleshooting chart represents a quick and easy procedure for checking these vital systems yourself. However, should your ATV require any repair, take it to a Yamaha dealer, whose skilled technicians have the necessary tools, experience, and know-how to service the ATV properly. Use only genuine Yamaha replacement parts. Imitation parts may look like Yamaha parts, but they are often inferior, have a shorter service life and can lead to expensive repair bills.

EWB02280



**WARNING**

**Do not smoke when checking the fuel system. Fuel can ignite or explode, causing severe injury or property damage. Make sure there are no open flames or sparks in the area, including pilot lights from water heaters or furnaces.**



# Troubleshooting chart

## 1. Fuel

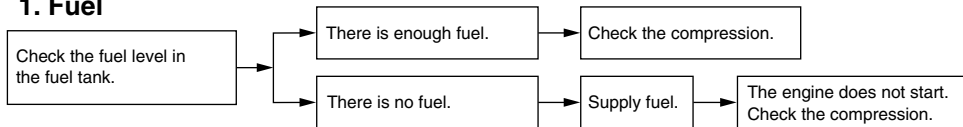

## 2. Compression

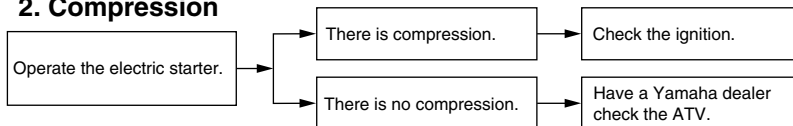

## 3. Ignition

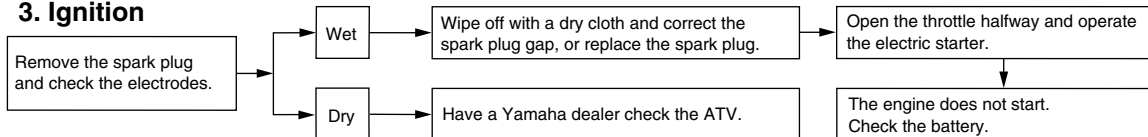

## 4. Battery

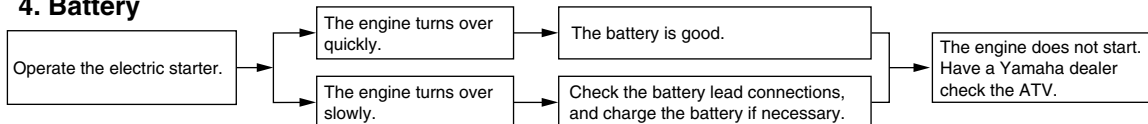

## CLEANING AND STORAGE

EBU25880

### Cleaning

Frequent, thorough cleaning of your ATV will not only enhance its appearance but will improve its general performance and extend the useful life of many components.

1. Before cleaning the ATV:
  - a. Block off the end of the exhaust pipe to prevent water entry. A plastic bag and strong rubber band may be used.
  - b. Make sure the spark plug and all filler caps are properly installed.
2. If the engine case is excessively greasy, apply degreaser with a paint brush. Do not apply degreaser to the wheel axles.
3. Rinse the dirt and degreaser off with a garden hose. Use only enough pressure to do the job.

ECB00710

#### **CAUTION:**

**Excessive water pressure may cause water seepage and deterioration of wheel bearings, brakes, transmission seals and electrical devices. Many expensive repair bills have result-**

**ed from improper high-pressure detergent applications such as those available in coin-operated car washers.**

- 
4. Once most of the dirt has been hosed off, wash all surfaces with warm water and mild, detergent-type soap. An old toothbrush or bottle brush is handy for hard-to-reach places.
  5. Rinse the ATV off immediately with clean water and dry all surfaces with a chamois, clean towel or soft absorbing cloth.
  6. Clean the seat with a vinyl upholstery cleaner to keep the cover pliable and glossy.
  7. Automotive type wax may be applied to all painted and chrome plated surfaces. Avoid combination cleaner-waxes. Many contain abrasives which may mar the paint or protective finish. When finished cleaning, start the engine and let it idle for several minutes.



**Wet brakes may have reduced stopping ability, increasing the chance of an accident. Test the brakes after washing. Apply the brakes several times at slow speeds to let friction dry out the linings.**

---

## Storage

### Short-term

Always store your ATV in a cool, dry place and, if necessary, protect it against dust with a porous cover.

### CAUTION:

- **Storing the ATV in a poorly ventilated room or covering it with a tarp while it is still wet, will allow water and humidity to seep in and cause rust.**
  - **To prevent corrosion, avoid damp cellars, stables (because of the presence of ammonia) and areas where strong chemicals are stored.**
- 

### Long-term

Before storing your ATV for several months:

1. Follow all the instructions in the “Cleaning” section of this chapter.
2. Turn the fuel cock lever to “OFF”.
3. Drain the carburetor float chamber by loosening the drain bolt; this will prevent fuel deposits from building up. Pour the drained fuel into the fuel tank.
4. Fill up the fuel tank and add fuel stabilizer (if available) to prevent the fuel from deteriorating.

Specified amount:

7.5 ml of stabilizer to each liter of fuel (or 1 oz of stabilizer to each gallon of fuel)

5. Perform the following steps to protect the cylinder, piston rings, etc. from corrosion.
  - a. Remove the spark plug cap and spark plug.
  - b. Pour a teaspoonful of engine oil into the spark plug bore.

- c. Install the spark plug cap onto the spark plug, and then place the spark plug on the cylinder head so that the electrodes are grounded. (This will limit sparking during the next step.)
  - d. Turn the engine over several times with the starter. (This will coat the cylinder wall with oil.)
  - e. Remove the spark plug cap from the spark plug, and then install the spark plug and the spark plug cap.
6. Lubricate all control cables and the pivoting points of all levers and pedals.
  7. Check and, if necessary, correct the tire air pressure, and then block up the ATV so that all of its wheels are off the ground. Alternatively, turn the wheels a little every month in order to prevent the tires from becoming degraded in one spot.
  8. Cover the muffler outlet with a plastic bag to prevent moisture from entering it.
  9. Remove the battery and fully charge it. Store it in a cool, dry place and charge it once a month. Do not store the battery in an excessively cold or warm place [less than 0 °C (30

°F) or more than 30 °C (90 °F)]. For more information on storing the battery, see page 8-39.

**NOTE:** \_\_\_\_\_  
Make any necessary repairs before storing the  
ATV.  
\_\_\_\_\_

# SPECIFICATIONS

## Dimensions:

- Overall length:  
1995 mm (78.5 in)
- Overall width:  
1095 mm (43.1 in)
- Overall height:  
1120 mm (44.1 in)
- Seat height:  
830 mm (32.7 in)
- Wheelbase:  
1235 mm (48.6 in)
- Ground clearance:  
245 mm (9.6 in)
- Minimum turning radius:  
3400 mm (134 in)

## Weight:

- With oil and fuel:  
275.0 kg (606 lb) (EUR)(GBR)  
279.0 kg (615 lb) (AUS)(NZL)

## Noise and vibration level:

- Noise level (77/311/EEC):  
77.6 dB(A) (EUR)(GBR)
- Vibration on seat (EN1032, ISO5008):  
Will not exceed 0.5 m/s<sup>2</sup> (EUR)(GBR)
- Vibration on handlebar (EN1032, ISO5008):  
Will not exceed 2.5 m/s<sup>2</sup> (EUR)(GBR)

## Engine:

- Engine type:  
Air cooled 4-stroke, SOHC
- Cylinder arrangement:  
Forward-inclined single cylinder
- Displacement:  
348.0 cm<sup>3</sup>
- Bore × stroke:  
83.0 × 64.5 mm (3.27 × 2.54 in)
- Compression ratio:  
9.20 :1
- Starting system:  
Electric and recoil starter
- Lubrication system:  
Wet sump

## Engine oil:

Type:

SAE5W30 or SAE10W30 or SAE10W40 or SAE15W40  
or SAE20W40 or SAE20W50

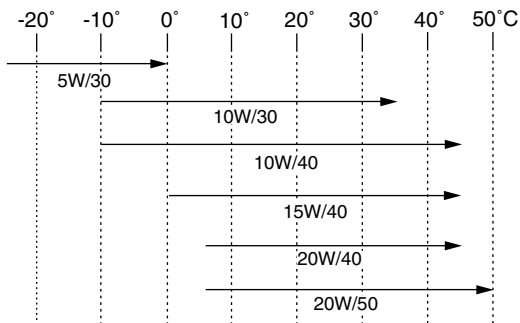

Recommended engine oil grade:

API service SG type or higher, JASO standard MA

Engine oil quantity:

Without oil filter cartridge replacement:

2.20 L (2.33 US qt) (1.94 Imp.qt)

With oil filter cartridge replacement:

2.30 L (2.43 US qt) (2.02 Imp.qt)

## Final gear oil:

Type:

Yamaha Friction Modified Shaft Drive Gear Oil  
(EUR)(GBR)

Yamaha Friction Modified Shaft Drive Gear Oil (Part No.:  
ACC-SHAFT-LU-00) (AUS)(NZL)

Quantity:

0.50 L (0.53 US qt) (0.44 Imp.qt)

## Differential gear oil:

Type:

Yamaha Friction Modified Shaft Drive Gear Oil (Part No.:  
ACC-SHAFT-LU-00) or SAE80 API GL-4 Hypoid gear oil  
(AUS)(NZL)

Yamaha Friction Modified Shaft Drive Gear Oil or SAE80  
API GL-4 Hypoid gear oil (EUR)(GBR)

Quantity:

0.23 L (0.24 US qt) (0.20 Imp.qt)

## Air filter:

Air filter element:

Wet element

## Fuel:

Recommended fuel:

Regular unleaded gasoline only (EUR)(GBR)

Unleaded gasoline only (AUS)(NZL)

Fuel tank capacity:

13.5 L (3.57 US gal) (2.97 Imp.gal)

Fuel reserve amount:

3.3 L (0.87 US gal) (0.73 Imp.gal)

## Carburetor:

Manufacturer:

MIKUNI

Type x quantity:

BSR33 x 1

## Spark plug (s):

Manufacturer/model:

NGK/DR8EA

Spark plug gap:  
0.6–0.7 mm (0.024–0.028 in)

### **Clutch:**

Clutch type:  
Wet, centrifugal automatic

### **Transmission:**

Primary reduction system:  
V-belt  
Secondary reduction system:  
Shaft drive  
Secondary reduction ratio:  
41/21 × 24/18 × 33/9 (9.545)

Transmission type:  
V-belt automatic

Operation:  
Left hand operation

Forward gear:  
35/20 (1.750)

Reverse gear:  
26/15 (1.733)

### **Chassis:**

Frame type:  
Steel tube frame

Caster angle:  
2.5 °

Trail:  
8.5 mm (0.33 in)

### **Front tire:**

Type:  
Tubeless

Size:  
AT25 x 8-12

Manufacturer/model:  
CHENG SHIN/C-828 (AUS)(NZL)  
MAXXIS/M979 (EUR)(GBR)

### **Rear tire:**

Type:  
Tubeless

Size:  
AT25 x 10-12  
Manufacturer/model:  
CHENG SHIN/C-828 (AUS)(NZL)  
MAXXIS/M980 (EUR)(GBR)

### **Loading:**

Maximum loading limit:  
210.0 kg (463 lb)  
(Total weight of rider, cargo, accessories, and tongue)

### **Tire air pressure (measured on cold tires):**

Recommended:  
Front:  
25.0 kPa (3.6 psi) (0.250 kgf/cm<sup>2</sup>)

Rear:  
25.0 kPa (3.6 psi) (0.250 kgf/cm<sup>2</sup>)

Minimum:  
Front:  
22.0 kPa (3.2 psi) (0.220 kgf/cm<sup>2</sup>)

Rear:  
22.0 kPa (3.2 psi) (0.220 kgf/cm<sup>2</sup>)

Maximum:  
Front:  
28.0 kPa (4.1 psi) (0.280 kgf/cm<sup>2</sup>)

Rear:

28.0 kPa (4.1 psi) (0.280 kgf/cm<sup>2</sup>)

**Front wheel:**

Wheel type:

Panel wheel

Rim size:

12 x 6.0AT

**Rear wheel:**

Wheel type:

Panel wheel

Rim size:

12 x 7.5AT

**Front brake:**

Type:

Dual disc brake

Operation:

Right hand operation

Recommended fluid:

DOT 4

**Rear brake:**

Type:

Wet multiple disc brake

Operation:

Left hand and right foot operation

**Front suspension:**

Type:

Double wishbone

Spring/shock absorber type:

Coil spring/oil damper

Wheel travel:

160 mm (6.3 in)

**Rear suspension:**

Type:

Double wishbone

Spring/shock absorber type:

Coil spring/oil damper

Wheel travel:

180 mm (7.1 in)

**Electrical system:**

Ignition system:

DC. CDI

Charging system:

AC magneto

**Battery:**

Model:

YTX14AH

Voltage, capacity:

12 V, 12.0 Ah

**Headlight:**

Bulb type:

Krypton bulb

**Bulb voltage, wattage x quantity:**

Headlight:

12 V, 30.0/30.0 W x 2

Tail/brake light:

12 V, 5.0/21.0 W x 1

Meter lighting:

12 V, 1.7 W x 1

Neutral indicator light:

12 V, 1.7 W x 1

Reverse indicator light:

12 V, 1.7 W x 1



Oil temperature warning light:

12 V, 1.7 W × 1

On-command four-wheel-drive indicator light:

12 V, 1.7 W × 1

Differential gear lock indicator light:

12 V, 1.7 W x 1

**Fuses:**

Main fuse:

30.0 A

Headlight fuse:

15.0 A

Signaling system fuse:

10.0 A

Ignition fuse:

15.0 A

Auxiliary DC jack fuse:

10.0 A

Four-wheel-drive motor fuse:

10.0 A

## CONSUMER INFORMATION

EBU26011

### Identification numbers

Record the key identification number, vehicle identification number and model label information in the spaces provided below for assistance when ordering spare parts from a Yamaha dealer or for reference in case the ATV is stolen.

KEY IDENTIFICATION NUMBER:

VEHICLE IDENTIFICATION NUMBER:

MODEL LABEL INFORMATION:



EBU26020

### Key identification number

The key identification number is stamped into the key. Record this number in the space provided and use it for reference when ordering a new key.

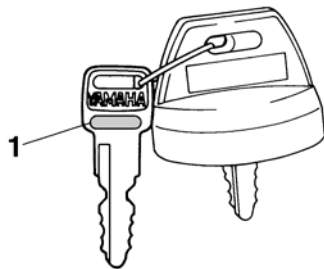

1. Key identification number

EBU26040

### Vehicle identification number

The vehicle identification number is stamped into the frame.

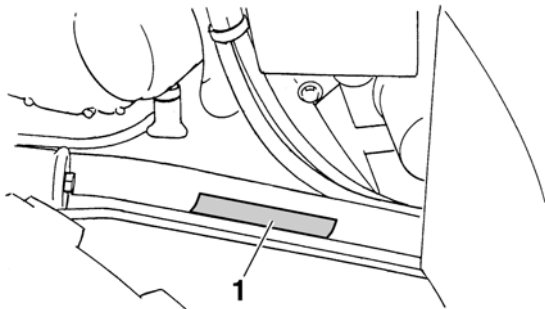

1. Vehicle identification number (front left side)

The year of manufacture is listed in the vehicle identification number as shown in the illustration.

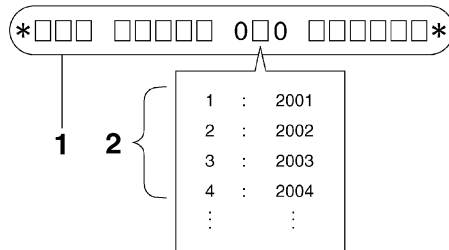

1. Vehicle identification number
2. Year of manufacture

**NOTE:** \_\_\_\_\_  
 The vehicle identification number is used to identify your ATV.

EBU26050

**Model label**

The model label is affixed at the location in the illustration. Record the information on this label in the space provided. This information will be needed when ordering spare parts from a Yamaha dealer.

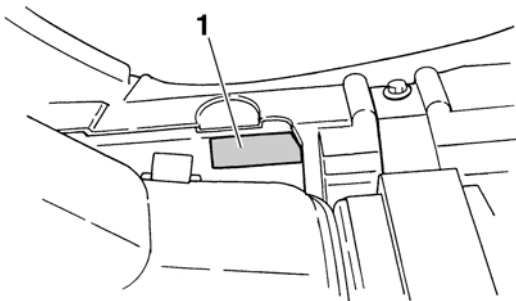

1. Model label

# INDEX

## A

- Accessories and loading ..... 6-6
- Air filter element, cleaning ..... 8-19
- Axle boots ..... 8-34

## B

- Battery ..... 8-39
- Brake fluid, changing ..... 8-29
- Brake fluid level, checking ..... 8-28
- Brake lever free play, checking the front ..... 8-29
- Brake lever, front ..... 4-11
- Brake levers, checking and lubricating ..... 8-36
- Brake light switches ..... 8-35
- Brake pads and friction plates, checking ..... 8-27
- Brake pedal and brake lever free play (rear) and  
brake pedal position, adjusting and checking ..... 8-30
- Brake pedal and rear brake lever ..... 4-11
- Brake pedal, checking and lubricating ..... 8-37
- Brakes, front and rear ..... 5-3

## C

- Cables, checking and lubricating ..... 8-36
- Carburetor, adjusting ..... 8-24
- Carrier, front ..... 4-19
- Carrier, rear ..... 4-19
- Chassis fasteners ..... 5-7
- Cleaning ..... 9-1

## D

- Differential gear lock indicator light ..... 4-3
- Differential gear oil ..... 5-3, 8-17

- Drive select lever ..... 4-12
- Drive select lever and driving in reverse ..... 6-3
- Drive select lever safety system cable, adjusting ..... 8-27
- Drive shaft universal joint, lubricating ..... 8-37

## E

- Engine break-in ..... 6-4
- Engine, cold start ..... 6-1
- Engine idling speed ..... 8-25
- Engine oil ..... 5-3
- Engine oil and oil filter cartridge ..... 8-10
- Engine, starting a warm ..... 6-3
- Engine stop switch ..... 4-4

## F

- Final gear oil ..... 5-3, 8-14
- Four-wheel-drive indicator light ..... 4-3
- Fuel ..... 4-14, 5-3
- Fuel cock ..... 4-15
- Fuel tank cap ..... 4-13
- Fuses, replacing ..... 8-40

## H

- Handlebar switches ..... 4-4
- Headlight beam, adjusting ..... 8-44
- Headlight bulb, replacing ..... 8-42
- Horn switch ..... 4-5

## I

- Identification numbers ..... 11-1
- Indicator lights and warning light ..... 4-2
- Instruments, lights and switches ..... 5-7

<b>K</b>		Seat .....	4-17
	Key identification number .....	Shock absorber assemblies, adjusting the front and rear .....	4-19
	Knuckle pivots, lubricating .....	Spark arrester, cleaning .....	8-22
<b>L</b>		Spark plug, checking .....	8-8
	Label locations .....	Specifications .....	10-1
	Light switch .....	Speed limiter .....	4-10
<b>M</b>		Speedometer .....	4-3
	Main switch .....	Stabilizer bushes, checking .....	8-38
	Model label .....	Starter (choke) .....	4-16
<b>N</b>		Start switch .....	4-5
	Neutral indicator light .....	Steering shaft, lubricating .....	8-38
<b>O</b>		Storage .....	9-2
	Oil temperature warning light .....	Storage compartment .....	4-18
	On-Command differential gear lock switch .....	<b>T</b>	
	On-Command four-wheel-drive switch .....	Tail/brake light bulb, replacing .....	8-44
	Override switch .....	Throttle cable free play, adjusting .....	8-26
	Owner's manual and tool kit .....	Throttle lever .....	4-9, 5-4
<b>P</b>		Tire pressure, measuring .....	5-5
	Panel, removing and installing .....	Tires .....	5-4
	Parking .....	Tire wear limit .....	5-6
	Parking brake .....	Troubleshooting .....	8-46
	Parking on a slope .....	Troubleshooting chart .....	8-47
	Part locations .....	<b>V</b>	
	Periodic maintenance and lubrication chart .....	Valve clearance .....	8-26
	Pre-operation check list .....	V-belt case drain plug .....	8-24
<b>R</b>		V-belt cooling duct check hose .....	8-24
	Recoil starter .....	Vehicle identification number .....	11-1
	Reverse indicator light .....	<b>W</b>	
	Riding your ATV .....	Wheel bearings, checking .....	8-37
<b>S</b>		Wheel, installing .....	8-45
	Safety information .....	Wheel, removing .....	8-44





PRINTED IN USA  
2006.10-0.3x2 CR  
(E)