



OWNER'S MANUAL
MANUEL DU PROPRIÉTAIRE
MANUAL DEL PROPIETARIO

BANSHEE
YFZ350W

3B5-28199-61

PRINTED ON RECYCLED PAPER
IMPRIMÉ SUR PAPIER RECYCLÉ
IMPRESO EN PAPEL RECICLADO



YAMAHA MOTOR CO., LTD.

PRINTED IN JAPAN
2006.07-0.7x1 
(E,F,S)



OWNER'S MANUAL

BANSHEE

YFZ350W

3B5-28199-61-E0

INTRODUCTION

Congratulations on your purchase of the Yamaha YFZ350W. This ATV represents the result of many years of Yamaha experience in the production of fine sporting, touring, and pacesetting racing machines. With the purchase of this Yamaha, you can now appreciate the high degree of craftsmanship and reliability that have made Yamaha a leader in these fields.

This manual will provide you with a good basic understanding of the features and operation of this ATV. **This manual includes important safety information. It provides information about special techniques and skills necessary to ride the ATV.** It also includes basic maintenance and inspection procedures. If you have any questions regarding the operation or maintenance of your ATV, please consult a Yamaha dealer.



AN IMPORTANT SAFETY MESSAGE:

- READ THIS MANUAL COMPLETELY BEFORE OPERATING YOUR ATV. MAKE SURE YOU UNDERSTAND ALL INSTRUCTIONS.
- PAY CLOSE ATTENTION TO THE WARNING AND CAUTION LABELS ON THE ATV.
- THIS ATV, AND ANY OTHER ATV OVER 90 cc, SHOULD NOT BE RIDDEN BY ANYONE UNDER 16 YEARS OF AGE.
- THIS ATV IS A HIGH-PERFORMANCE ATV FOR OFF-ROAD USE ONLY, FOR SPORT-TYPE RECREATIONAL AND COMPETITIVE USE BY EXPERIENCED OPERATORS.

IMPORTANT MANUAL INFORMATION

FAILURE TO FOLLOW THE WARNINGS CONTAINED IN THIS MANUAL CAN RESULT IN SERIOUS INJURY OR DEATH.

Particularly important information is distinguished in this manual by the following notations:

	The Safety Alert Symbol means ATTENTION! BECOME ALERT! YOUR SAFETY IS INVOLVED!
	Failure to follow WARNING instructions <u>could result in severe injury or death</u> to the ATV operator, a bystander, or a person inspecting or repairing the ATV.
CAUTION:	A CAUTION indicates special precautions that must be taken to avoid damage to the ATV.
NOTE:	A NOTE provides key information to make procedures easier or clearer.

* Product and specifications are subject to change without notice.

EBU17350

IMPORTANT NOTICE

EBU17370

Welcome to the Yamaha world of motor sports!

This ATV is designed and manufactured for use on UNPAVED surfaces only. It is unsafe to operate this ATV on any paved surface, paved street, paved road or motorway.

Please check your local riding laws and regulations before operating this ATV.

EBU17390

**YFZ350W
OWNER'S MANUAL
©2006 by Yamaha Motor Co., Ltd.
1st edition, June 2006
All rights reserved.
Any reprinting or unauthorized use
without the written permission of
Yamaha Motor Co., Ltd.
is expressly prohibited.
Printed in Japan.**

TABLE OF CONTENTS

SAFETY INFORMATION	1-1	Fuel cock	4-9
LOCATION OF THE WARNING AND SPECIFICATION LABELS	2-1	Starter (choke)	4-10
DESCRIPTION	3-1	Seat	4-11
Left view	3-1	Adjusting the front shock absorber assemblies	4-12
Right view	3-1	Adjusting the rear shock absorber assembly	4-13
Controls and instruments	3-2	PRE-OPERATION CHECKS	5-1
INSTRUMENT AND CONTROL FUNCTIONS	4-1	Pre-operation check list	5-1
Main switch	4-1	Fuel and 2-stroke engine oil mixing ratio ...	5-4
Handlebar switches	4-2	Transmission oil	5-4
Throttle lever	4-2	Coolant	5-4
Throttle OverRide System	4-3	Front and rear brakes	5-4
Speed limiter	4-3	Throttle lever	5-5
Clutch lever	4-4	Drive chain	5-5
Brake lever	4-5	Tires	5-6
Brake pedal	4-5	Measuring the tire pressure	5-7
Parking brake	4-5	Tire wear limit	5-7
Shift pedal	4-7	Chassis fasteners	5-8
Kickstarter	4-7	Instruments, lights and switches	5-8
Fuel tank cap	4-7	OPERATION	6-1
Fuel	4-8	Starting a cold engine	6-1
		Starting a warm engine	6-2
		Shifting	6-3

Engine break-in	6-4	Cleaning the air filter element	8-16
Parking	6-5	Cleaning the spark arrester	8-19
Parking on a slope	6-6	Changing the carburetor settings	8-21
Accessories and loading	6-6	Adjusting the engine idling speed	8-28
RIDING YOUR ATV	7-1	Adjusting the throttle cable free play	8-30
GETTING TO KNOW YOUR ATV.....	7-2	Checking the front and rear brake pads	8-31
RIDE WITH CARE AND GOOD JUDGEMENT	7-2	Checking the brake fluid level	8-32
BE CAREFUL WHERE YOU RIDE.....	7-8	Changing the brake fluid	8-33
TURNING YOUR ATV	7-12	Checking the front brake lever free play	8-33
CLIMBING UPHILL	7-14	Checking the brake pedal position	8-34
RIDING DOWNHILL.....	7-16	Adjusting the parking brake free play	8-35
CROSSING A SLOPE.....	7-17	Brake light switches	8-37
CROSSING THROUGH SHALLOW WATER	7-18	Adjusting the clutch lever free play	8-37
RIDING OVER ROUGH TERRAIN	7-20	Drive chain slack	8-38
SLIDING AND SKIDDING	7-20	Lubricating the drive chain	8-40
WHAT TO DO IF...	7-21	Checking and lubricating the cables	8-41
WHAT TO DO...	7-21	Checking and lubricating the brake and clutch levers	8-42
PERIODIC MAINTENANCE AND MINOR REPAIR	8-1	Checking and lubricating the brake and shift pedals	8-42
Owner's manual and tool kit	8-1	Checking the wheel bearings	8-42
Periodic maintenance and lubrication chart	8-3	Lubricating the rear suspension relay arm and connecting arm pivoting points	8-42
Checking the spark plugs	8-7	Lubricating the upper and lower arm pivots	8-43
Transmission oil	8-9	Replacing a headlight bulb	8-44
Coolant	8-11		

Adjusting a headlight beam	8-47
Replacing the tail/brake light bulb	8-47
Removing a wheel	8-48
Installing a wheel	8-49
Troubleshooting	8-49
Troubleshooting charts	8-51
CLEANING AND STORAGE.....	9-1
Cleaning	9-1
Storage	9-2
SPECIFICATIONS	10-1
CONSUMER INFORMATION	11-1
Identification numbers	11-1



SAFETY INFORMATION

EBU17591

AN ATV IS NOT A TOY AND CAN BE HAZARDOUS TO OPERATE.

An ATV handles differently from other vehicles, including motorcycles and cars. A collision or rollover can occur quickly, even during routine maneuvers such as turning and riding on hills or over obstacles, if you fail to take proper precautions.

SEVERE INJURY OR DEATH can result if you do not follow these instructions:

- Read this manual and all labels carefully and follow the operating procedures described.
- Never operate an ATV without proper training or instruction.
- Always follow the age recommendation:
 - A child under 16 years old should never operate an ATV with engine size greater than 90 cc.
- Never allow a child under age 16 to operate an ATV without adult supervision, and never allow continued use of an ATV by a child if he or she

does not have the abilities to operate it safely.

- Never carry a passenger on an ATV.
- Always avoid operating an ATV on any paved surfaces, including sidewalks, driveways, parking lots and paved streets.
- Never operate an ATV on any paved street, paved road or motorway.
- Watch carefully for other vehicles when operating on unpaved public streets or roads. Make sure you know your country's laws and regulations before you ride on unpaved public streets or roads.
- Never operate an ATV without wearing an approved motorcycle helmet that fits properly. You should also wear eye protection (goggles or face shield), gloves, boots, a long-sleeved shirt or a jacket, and long pants.
- Never consume alcohol or drugs before or while operating this ATV.
- Never operate at speeds too fast for your skills or the riding conditions. Always go at a speed

that is proper for the terrain, visibility, operating conditions, and your experience.

- Never attempt wheelies, jumps, or other stunts.
- Always inspect your ATV each time you use it to make sure it is in safe operating condition. Always follow the inspection and maintenance procedures and schedules described in this manual.
- Always keep both hands on the handlebars and both feet on the footrests of the ATV during operation.
- Always go slowly and be extra careful when operating on unfamiliar terrain. Always be alert to changing terrain conditions when operating the ATV.
- Never operate on excessively rough, slippery or loose terrain until you have learned and practiced the skills necessary to control the ATV on such terrain. Always be especially cautious on these kinds of terrain.
- Always follow proper procedures for turning as described in this manual. Practice turning at low speeds before attempting to turn at faster speeds and never turn at excessive speeds.
- Never operate the ATV on hills too steep for the ATV or for your abilities. Practice on smaller hills

before attempting larger hills.

- Always follow proper procedures for climbing hills as described in this manual. Check the terrain carefully before you start up any hill. Never climb hills with excessively slippery or loose surfaces. Shift your weight forward. Never open the throttle suddenly or make sudden gear changes. Never go over the top of a hill at high speed.
- Always follow proper procedures for going down hills and for braking on hills as described in this manual. Check the terrain carefully before you start down any hill. Shift your weight backward. Never go down a hill at high speed. Avoid going down a hill at an angle that would cause the vehicle to lean sharply to one side. Go straight down the hill where possible.
- Always follow proper procedures for crossing the side of a hill as described in this manual. Avoid hills with excessively slippery or loose surfaces. Shift your weight to the uphill side of the ATV. Never attempt to turn the ATV around on any hill until you have mastered the turning technique described in this manual on level ground. Avoid crossing the side of a steep hill if possible.
- Always use proper procedures if you stall or roll backwards when climbing a hill. To avoid stall-

ing, use the proper gear and maintain a steady speed when climbing a hill. If you stall or roll backwards, follow the special procedure for braking described in this manual. Dismount on the uphill side or to a side if pointed straight uphill. Turn the ATV around and remount, following the procedure described in this manual.

- Always check for obstacles before operating in a new area.
- Never attempt to operate over large obstacles, such as large rocks or fallen trees. Always follow proper procedures when operating over obstacles as described in this manual.
- Always be careful when skidding or sliding. Learn to safely control skidding or sliding by practicing at low speeds and on level, smooth terrain. On extremely slippery surfaces, such as ice, go slowly and be very cautious in order to reduce the chance of skidding or sliding out of control.
- Never operate an ATV in fast flowing water or in water deeper than that recommended in this manual. Remember that wet brakes may have reduced stopping ability. Test your brakes after leaving water. If necessary, apply them several times to let friction dry out the linings.

- Always use the size and type of tires specified in this manual.
- Always maintain proper tire pressure as described in this manual.
- Never modify an ATV through improper installation or use of accessories.
- Never exceed the stated load capacity for an ATV. Cargo should be properly distributed and securely attached. Reduce speed and follow instructions in this manual for carrying cargo or pulling a trailer. Allow greater distance for braking.

EWB00061

WARNING

- **Always turn off the engine when refueling.**
- **Do not refuel right after the engine has been running and is still very hot.**
- **Do not spill gasoline on the engine or exhaust pipe/muffler when refueling. Never refuel while smoking, or in the vicinity of sparks, open flames, or other sources of ignition such as the pilot lights of water heaters and clothes dryers. Gasoline can catch fire and you could be burned.**
- **When transporting the ATV in another vehicle, be sure it is kept upright and that the fuel**

1

cock is in the “OFF” position. Otherwise, fuel may leak out of the carburetor or fuel tank.

- Gasoline is poisonous. If you should swallow some gasoline or inhale a lot of gasoline vapor, or get some gasoline in your eyes, seek medical help immediately. If gasoline spills on your skin, wash with soap and water. If gasoline spills on your clothing, change your clothes.

and may cause loss of consciousness and death within a short time.

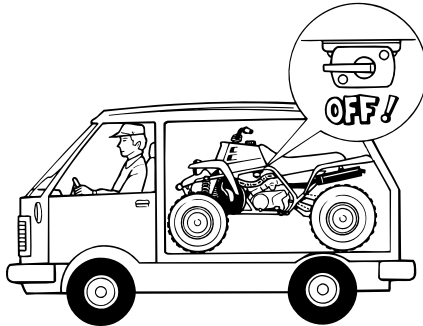

EWB00070

⚠ WARNING

Always operate your ATV in an area with adequate ventilation. Never start or run the engine in a closed area. Exhaust fumes are poisonous

LOCATION OF THE WARNING AND SPECIFICATION LABELS

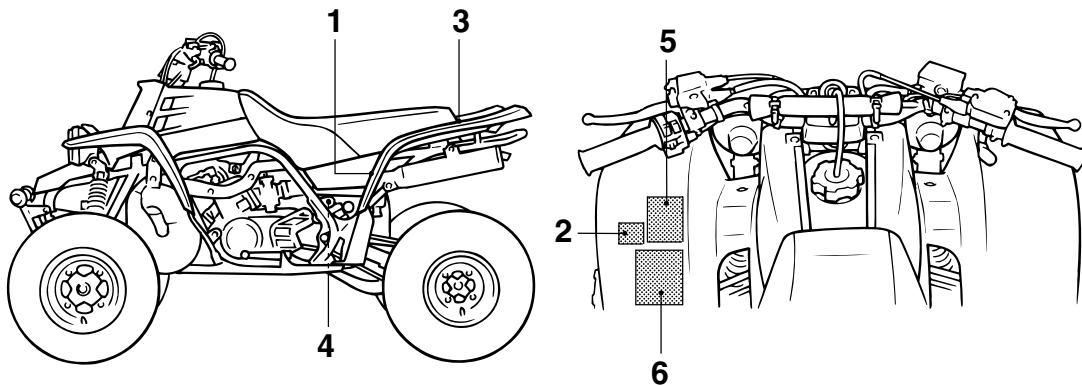



Read and understand all of the labels on your ATV. These labels contain important information for safe and proper operation.

2

Never remove any labels from your ATV. If a label becomes difficult to read or comes off, request a replacement label from your Yamaha dealer.

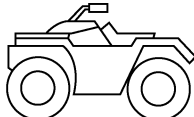
1 For Europe

	
	
30 kPa 0.30 kgf/cm ² 4.4 psi	30 kPa 0.30 kgf/cm ² 4.4 psi
(GB) Set with tires cold.	(I) Impostare a pneumatici freddi.
(D) Bei kalten Reifen.	(NL) Wanneer de banden koud zijn.
(E) Ajuste con los neumáticos en frío.	(P) Regular com pneus frios.
(F) Pneus à froid.	(S) Ställ in med kalla däck.
<small>5FK-21696-M0</small>	

1 For Oceania

 WARNING
IMPROPER TIRE PRESSURE OR OVERLOADING CAN CAUSE LOSS OF CONTROL. LOSS OF CONTROL CAN RESULT IN SEVERE INJURY OR DEATH.
OPERATING TIRE PRESSURE: Set with tires cold
•Recommended : FRONT : 30 kPa, {0.30 kgf/cm ² } 4.4 psi REAR : 30 kPa, {0.30 kgf/cm ² } 4.4 psi
•Minimum : FRONT : 27 kPa, {0.27 kgf/cm ² } 3.9 psi REAR : 27 kPa, {0.27 kgf/cm ² } 3.9 psi
•Never set tire pressure below minimum. It could cause the tire to dislodge from the rim.
LOADING
•Maximum Vehicle Load : 100 kg, (220 lbs). Includes weight of operator, cargo and accessories.
<small>5FK-21696-01</small>

2

2 For Europe

YAMAHA MOTOR CO., LTD. SHIZUOKA JAPAN
YAMAHA <small>4GB-2155A-00</small>

3 For Europe



3 For Oceania



4



5 For Europe

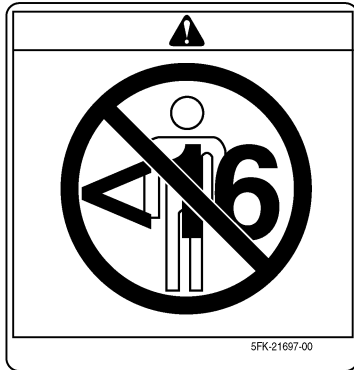





5 For Oceania



6 For Europe





GB Before you operate this vehicle, read the owner's manual.

D Lesen Sie die Bedienungsanleitung bevor Sie dieses Fahrzeug fahren.

E Antes de conducir este vehículo, lea el Manual del Propietario.

F Lire le manuel du propriétaire avant d'utiliser ce véhicule.

I Prima di usare il veicolo, leggete il manuale di istruzioni.

NL Voor het gebruik van dit voertuig de handleiding met aandacht lezen.

P Antes de utilizar este veículo, leia o manual do proprietário.

S Innan du kör detta fordon, läs handboken.

5FK-21568-00

6 For Oceania



WARNING

Improper ATV use can result in SEVERE INJURY or DEATH.





ALWAYS USE AN APPROVED HELMET AND PROTECTIVE GEAR

NEVER USE ON PUBLIC ROADS

NEVER CARRY PASSENGERS

NEVER USE WITH DRUGS OR ALCOHOL

NEVER operate :

- without proper training or instruction.
- at speeds too fast for your skills or the conditions.
- on public roads-a collision can occur with another vehicle.
- with a passenger-passengers affect balance and steering and increase risk of losing control.

ALWAYS :

- use proper riding techniques to avoid vehicle overturns on hills and rough terrain and it turns.
- avoid paved surfaces-pavement may seriously affect handling and control.

LOCATE AND READ OWNER'S MANUAL.
FOLLOW ALL INSTRUCTIONS AND WARNINGS.

5FE-21568-11

DESCRIPTION

EBU17690

Left view

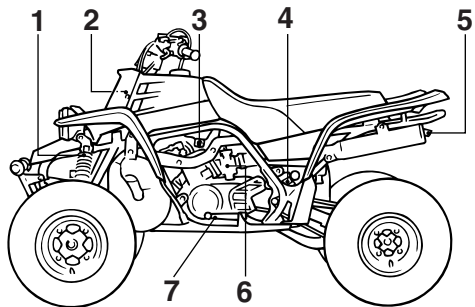

1. Front shock absorber assembly
2. Radiator
3. Fuel cock
4. Rear shock absorber assembly
5. Spark arrester
6. Starter (choke)
7. Shift pedal

EBU17700

Right view

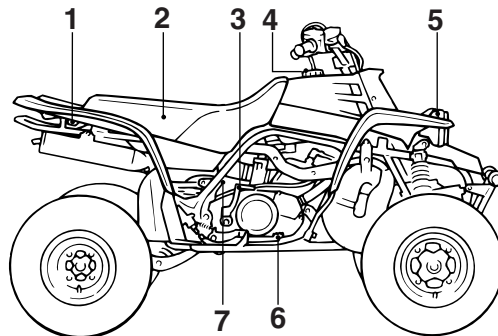

1. Tail/brake light
2. Seat
3. Kickstarter
4. Fuel tank cap
5. Headlight
6. Brake pedal
7. Brake light switch

Controls and instruments

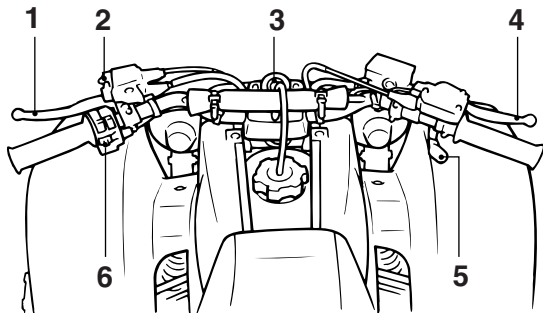

1. Clutch lever
2. Parking brake lock plate
3. Main switch
4. Brake lever
5. Throttle lever
6. Handlebar switches

NOTE:

The ATV you have purchased may differ slightly from the figures shown in this manual.

INSTRUMENT AND CONTROL FUNCTIONS

EBU17760

Main switch

The positions of the main switch are as follows:

ON

All electrical systems are supplied with power. The headlights and taillight come on when the light switch is on, and the engine can be started. The key cannot be removed.

OFF

All electrical systems are off. The key can be removed.

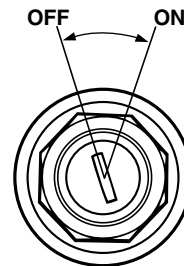

1. Main switch

Handlebar switches

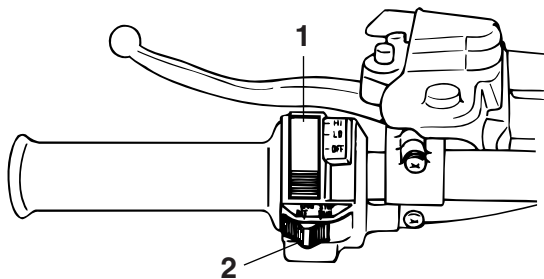

1. Light switch "LIGHTS"
2. Engine stop switch "ENG. STOP"

Engine stop switch "ENG. STOP"

Set this switch to "RUN" before starting the engine. The engine stop switch controls the ignition and stops the engine when it is running. Use this switch to stop the engine in an emergency situation. The engine will not start or run when this switch is set to "OFF".

Light switch "LIGHTS"

Set this switch to "LO" to turn on the low beams and the taillight. Set the switch to "HI" to turn on the high beams and the taillight. Set the switch to "OFF" to turn off all the lights.

CAUTION:

Do not use the headlights with the engine turned off for an extended period of time, otherwise the battery may discharge to the point that the starter motor will not operate properly. If this should happen, remove the battery and recharge it.

Throttle lever

Once the engine is running, movement of the throttle lever will increase the engine speed. Regulate the speed of the ATV by varying the throttle position. Because the throttle is spring-loaded, the ATV will decelerate, and the engine will return to an idle any time the hand is removed from the throttle lever.

Throttle OverRide System

If during operation, the carburetor or the throttle cable should malfunction and will not close fully, take your thumb off the throttle lever.

The throttle override system immediately cuts off the ignition.

EWB00260

WARNING

Riding with a malfunction increases the chance for an accident and injury. Make sure that the cause of the malfunction is corrected before restarting the engine or have the ATV inspected by a Yamaha dealer.

4

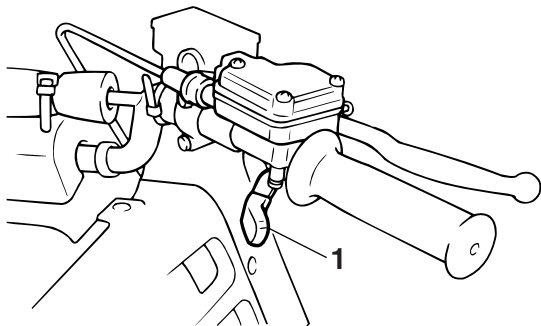

1. Throttle lever

Before starting the engine, check the throttle to be sure it is operating smoothly. Make sure it returns to the idle position as soon as the lever is released.

EWB00250

WARNING

Malfunction of the throttle could make it difficult to speed up or slow down when you need to. This could cause an accident. Check the operation of the throttle lever before you start the engine. If the throttle does not work smoothly, check for the cause. Correct the problem before riding the ATV or consult a Yamaha dealer.

EBU18321

Speed limiter

Your ATV was delivered with an adjustable speed limiter. The speed limiter keeps the throttle from fully opening, even when the throttle lever is pushed to the maximum.

1. Loosen the locknut.
2. To increase the maximum engine power available and the maximum speed of the ATV, turn the adjusting screw in direction (a). To decrease the maximum engine power available

and the maximum speed of the ATV, turn the adjusting screw in direction (b).

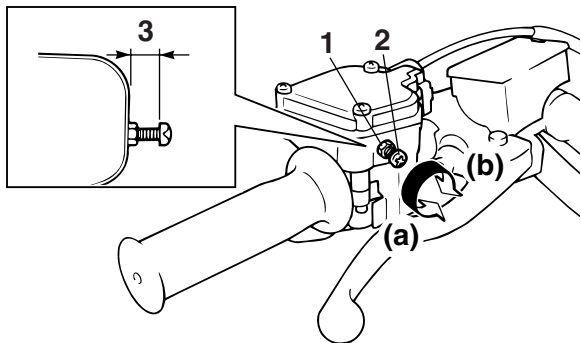

4

1. Locknut
2. Adjusting screw
3. No more than 12 mm (0.47 in)

3. Tighten the locknut.

EWB00240

WARNING

Improper adjustment of the speed limiter and throttle could cause throttle cable damage or improper throttle operation. You could lose control, have an accident or be injured. Do not turn the adjusting screw out more than 12 mm (0.47 in) or the throttle cable could be dam-

aged. Always make sure the throttle lever free play is adjusted to 4.0–6.0 mm (0.16–0.24 in). (See page 8-30.)

EBU18372

Clutch lever

The clutch lever is located on the left handlebar. To disengage the clutch, pull the clutch lever toward the handlebar grip. To engage the clutch, release the clutch lever. The clutch lever should be pulled rapidly and released slowly for smooth clutch operation.

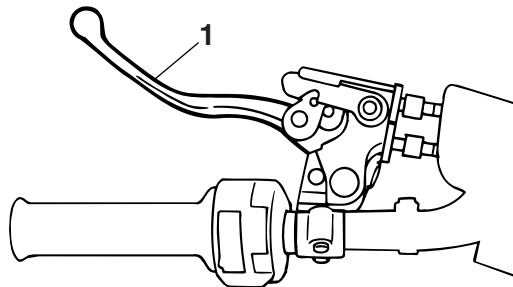

1. Clutch lever

EBU18411

Brake lever

The brake lever is located at the right handlebar grip. To apply the front brake, pull the brake lever toward the handlebar grip.

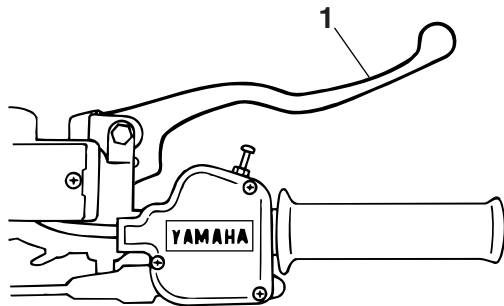

1. Brake lever

EBU18432

Brake pedal

The brake pedal is located on the right side of the ATV. To apply the rear brake, push down on the brake pedal.

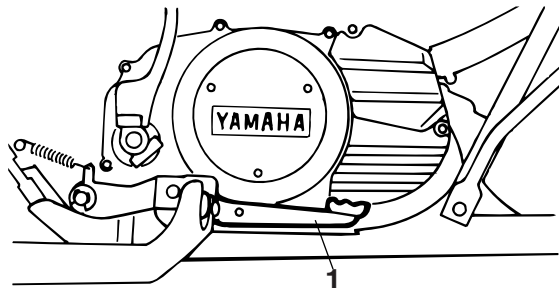

4

1. Brake pedal

EBU18500

Parking brake

Use the parking brake before starting the engine or parking the ATV, especially on a slope. Squeeze the clutch lever while pushing the button, then push in the lock plate to apply the parking brake. Squeeze the clutch lever to release the parking brake.

NOTE: _____

When the parking brake is used, engine speed is limited to 2300 r/min. Be sure the parking brake is released before moving the throttle lever. Other-

wise, the engine will misfire, preventing normal operation.

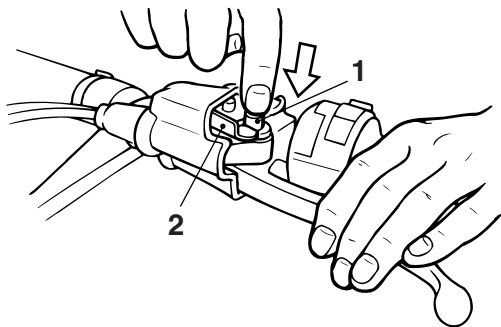

1. Button
2. Parking brake lock plate

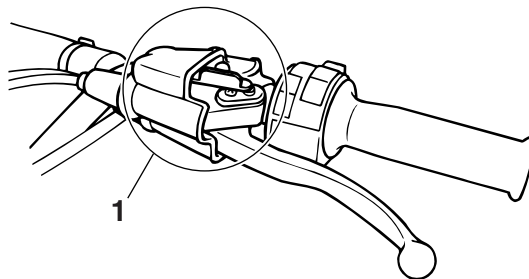

1. Locked position

EWB00220

WARNING

- **Always set the parking brake before starting the engine. The ATV could start moving unexpectedly if the parking brake is not applied. This could cause loss of control or a collision.**
- **Always be sure you have released the parking brake before you begin to ride. The brake could overheat if you ride the ATV without releasing the parking brake. You could lose braking performance which could cause an accident. You could also wear out the brakes**

prematurely.

EBU18530

Shift pedal

This ATV is equipped with a constant-mesh 6-speed transmission. The shift pedal is located on the left side of the engine and is used in combination with the clutch when shifting.

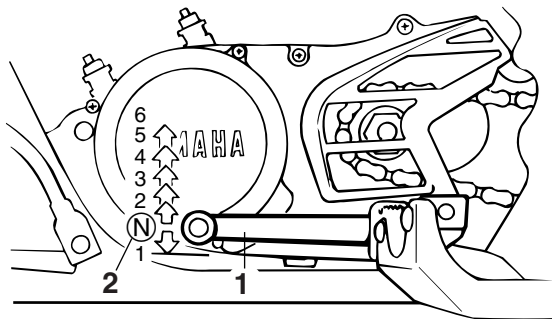

1. Shift pedal
2. Neutral position

EBU18650

Kickstarter

Fold out the kickstarter lever, move it down lightly with your foot until the gears engage, and then

push it down smoothly but forcefully. This model is equipped with a primary kickstarter, allowing the engine to be started in any gear if the clutch is disengaged. However, shifting the transmission into the neutral position before starting is recommended.

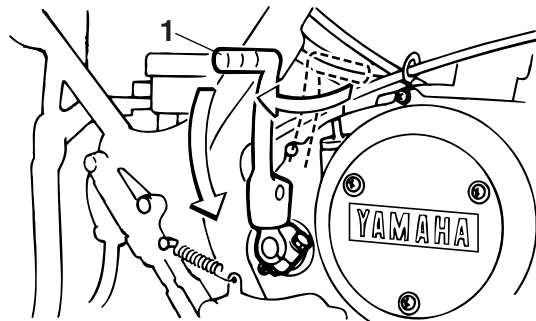

1. Kickstarter

EBU18720

Fuel tank cap

Remove the fuel tank cap by turning it counter-clockwise.

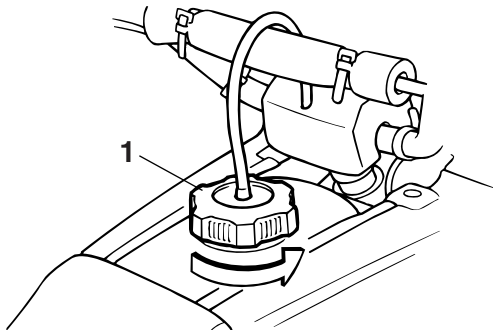

1. Fuel tank cap

EBU18770

Fuel

Make sure that there is sufficient fuel in the tank. Fill the fuel tank to the bottom of the filler tube as shown.

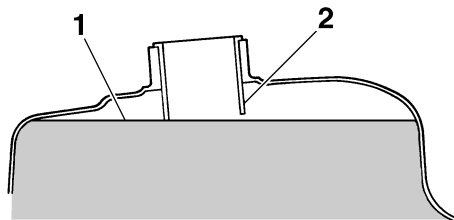

1. Fuel level
2. Filler tube

Recommended fuel:

PREMIUM UNLEADED GASOLINE ONLY
 For Europe: **PREMIUM UNLEADED GASOLINE ONLY** with a research octane number of 95 or higher.

Fuel tank capacity:

12.0 L (3.17 US gal) (2.64 Imp.gal)

Fuel reserve amount:

2.5 L (0.66 US gal) (0.55 Imp.gal)

NOTE: _____

If knocking or pinging occurs, use a different brand

of gasoline or higher octane grade.

ECB00060

CAUTION:

Use only unleaded gasoline. The use of leaded gasoline will cause severe damage to internal engine parts, such as the piston rings, as well as to the exhaust system.

EWB00310

WARNING

- Do not overfill the fuel tank. Fuel expands when it heats up. If the fuel tank is overfilled, fuel could spill out due to heat from the engine or the sun.
- Be careful not to spill fuel, especially on the engine or exhaust pipe which can cause a fire and severe injury. Wipe up any spilled fuel immediately.
- Do not refuel right after the engine has been running and is still very hot.
- Be sure the fuel tank cap is closed securely.

EBU18830

Fuel cock

The fuel cock supplies fuel from the tank to the carburetors while also filtering it.

The fuel cock lever positions are explained as follows and shown in the illustrations.

OFF

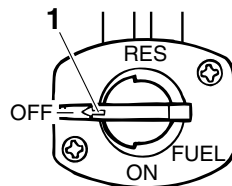

1. Arrow mark positioned over "OFF"

With the fuel cock lever in this position, fuel will not flow. Always turn the fuel cock lever to this position when the engine is not running.

ON

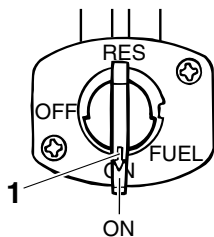

4

1. Arrow mark positioned over "ON"

With the fuel cock lever in this position, fuel flows to the carburetors. Turn the fuel cock lever to this position when starting the engine and riding.

RES

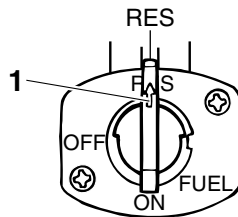

1. Arrow mark positioned over "RES"

This indicates reserve. With the fuel cock lever in this position, the fuel reserve is made available. Turn the fuel cock lever to this position if you run out of fuel while riding. When this occurs, refuel as soon as possible and be sure to turn the fuel cock lever back to "ON"!

EBU18840

Starter (choke)

Starting a cold engine requires a richer air-fuel mixture, which is supplied by the starter (choke).

Move the starter (choke) in direction (a) to turn on

the starter (choke).

Move the starter (choke) in direction (b) to turn off the starter (choke).

See the "Starting a cold engine" section on page 6-1 for proper operation.

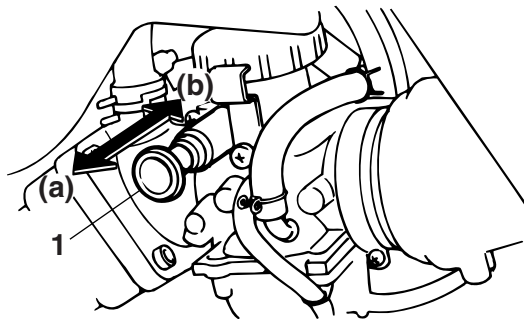

1. Starter (choke)

EBU18870

Seat

To remove the seat

Pull the seat lock lever upward and pull up the seat at the rear.

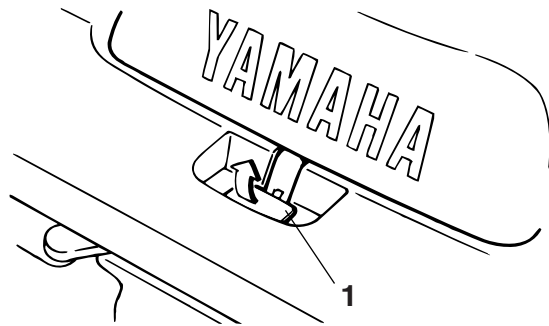

1. Seat lock lever

To install the seat

Insert the projection on the front of the seat into the seat holder and push down on the seat at the rear.

NOTE:

Make sure that the seat is securely fitted.

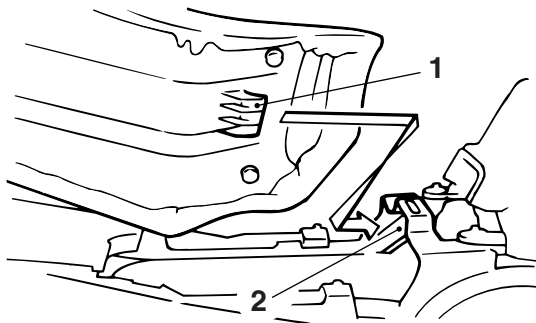

1. Projection
2. Seat holder

EBU18990

Adjusting the front shock absorber assemblies

The spring preload can be adjusted to suit the rider's weight and the riding conditions.

Adjust the spring preload as follows.

Turn the adjusting ring in direction (a) to increase the spring preload and thereby harden the suspension, and in direction (b) to decrease the spring preload and thereby soften the suspension.

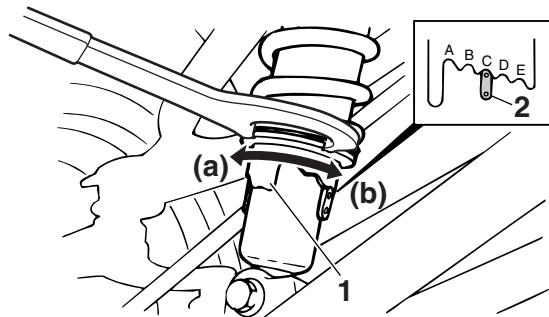

1. Spring preload adjusting ring
2. Position indicator

NOTE:

A special wrench can be obtained at a Yamaha dealer to make this adjustment.

Spring preload setting:

Minimum (soft):

A

Standard:

C

Maximum (hard):

E

⚠ WARNING

Always adjust the shock absorber assemblies on the left and right side to the same setting. Uneven adjustment can cause poor handling and loss of stability, which could lead to an accident.

Adjusting the rear shock absorber assembly

The spring preload, rebound damping and compression damping forces of the rear shock absorber assembly can be adjusted to suit the rider's weight and the riding conditions.

⚠ WARNING

This shock absorber assembly contains highly pressurized nitrogen gas. Read and understand the following information before handling the shock absorber assembly.

- Do not tamper with or attempt to open the cylinder assembly.
- Do not subject the shock absorber assembly to an open flame or other high heat source. This may cause the unit to explode due to ex-

cessive gas pressure.

- Do not deform or damage the cylinder in any way. Cylinder damage will result in poor damping performance.
- Do not dispose of a damaged or worn out shock absorber assembly yourself. Take the shock absorber assembly to a Yamaha dealer for any service.

Spring preload

1. Loosen the locknut.
2. Turn the adjusting nut in direction (a) to increase the spring preload and thereby harden the suspension, and in direction (b) to decrease the spring preload and thereby soften the suspension.

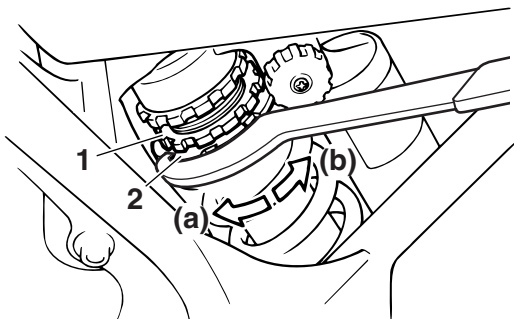

1. Locknut
2. Spring preload adjusting nut

NOTE:

- A special wrench can be obtained at a Yamaha dealer to make this adjustment.
- The spring preload setting is determined by measuring distance A, shown in the illustration. The shorter distance A is, the higher the spring preload; the longer distance A is, the lower the spring preload. With each complete turn of the adjusting nut, distance A is changed by 1.5 mm (0.06 in).

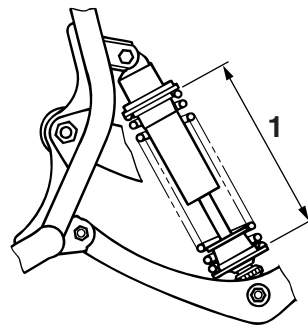

1. Distance A

Spring preload setting:

Minimum (hard):

Distance A = 213.5 mm (8.4 in)

Standard:

Distance A = 220.5 mm (8.7 in)

Maximum (soft):

Distance A = 228.5 mm (9.0 in)

3. Tighten the locknut to the specified torque.

Tightening torque:

Locknut:

54 Nm (5.4 m·kgf, 39 ft·lbf)

CAUTION:

Always tighten the locknut against the adjusting nut, and then tighten it to the specified torque.

Rebound damping force

Turn the adjusting dial in direction (a) to increase the rebound damping force and thereby harden the damping, and in direction (b) to decrease the rebound damping force and thereby soften the damping.

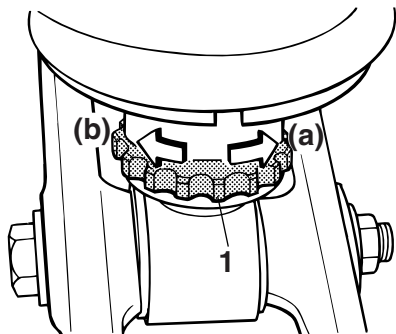

1. Rebound damping force adjusting dial

Rebound damping setting:

Minimum (soft):

20 click(s) in direction (b)*

Standard:

12 click(s) in direction (b)*

Maximum (hard):

3 click(s) in direction (b)*

* With the adjusting dial fully turned in direction (a)

Compression damping force

Turn the adjusting knob in direction (a) to increase the compression damping force and thereby harden the damping, and in direction (b) to decrease the compression damping force and thereby soften the damping.

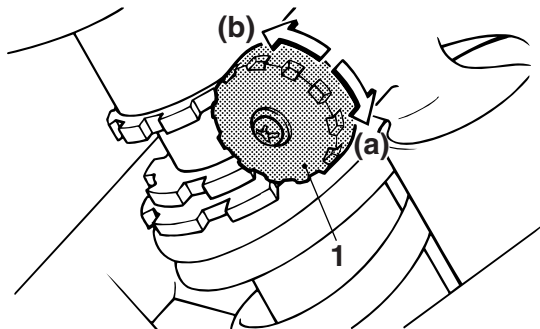

1. Compression damping force adjusting knob

Compression damping setting:

Minimum (soft):

1 click(s) in direction (a)*

Standard:

11 click(s) in direction (a)*

Maximum (hard):

15 click(s) in direction (a)*

* With the adjusting knob fully turned in direction (b)

ECB00090

CAUTION:

Never turn an adjusting mechanism beyond

the minimum and maximum settings.

NOTE:

Although the total number of clicks of a damping force adjusting mechanism may not exactly match the above specifications due to small differences in production, the actual number of clicks always represents the entire adjusting range. To obtain a precise adjustment, it would be advisable to check the number of clicks of each damping force adjusting mechanism and to modify the specifications as necessary.

EWB00460

WARNING

Suspension components become hot during operation. Never touch the compression damping force adjusting knob, the rebound damping force adjusting dial or the oil reservoir with your bare hand or skin until suspension components have cooled.

PRE-OPERATION CHECKS

EBU19220

Pre-operation check list

Before operating this ATV, be sure to check the items listed in the following table.

NOTE:

The maintenance of some items in the table has to be performed by a Yamaha dealer. Refer to the “Periodic maintenance and lubrication chart” on page 8-3 to determine which service should be performed by a Yamaha dealer.

ITEM	ROUTINE	PAGE
Fuel	<ul style="list-style-type: none"> ● Check fuel level in fuel tank, and add recommended fuel if necessary. ● Check fuel line for leakage. Correct if necessary. 	4-8, 5-4
Transmission oil	<ul style="list-style-type: none"> ● Check oil level in transmission case, and add recommended oil to specified level if necessary. ● Check ATV for oil leakage. Correct if necessary. 	5-4, 8-9
Coolant	<ul style="list-style-type: none"> ● Check coolant level in reservoir, and add recommended coolant to specified level if necessary. ● Check cooling system for leakage. Correct if necessary. 	5-4, 8-11
Front brake	<ul style="list-style-type: none"> ● Check operation. If soft or spongy, have Yamaha dealer bleed hydraulic system. ● Check brake pads for wear, and replace if necessary. ● Check brake fluid level in reservoir, and add recommended brake fluid to specified level if necessary. ● Check hydraulic system for leakage. Correct if necessary. 	5-4, 8-31, 8-32, 8-33

ITEM	ROUTINE	PAGE
Rear brake	<ul style="list-style-type: none"> ● Check operation. If soft or spongy, have Yamaha dealer bleed hydraulic system. ● Check brake pads for wear, and replace if necessary. ● Check brake fluid level in reservoir, and add recommended brake fluid to specified level if necessary. ● Check hydraulic system for leakage. Correct if necessary. 	5-4, 8-31, 8-32, 8-34
Clutch	<ul style="list-style-type: none"> ● Check operation, and correct if necessary. ● Lubricate cable if necessary. ● Check lever free play, and adjust if necessary. 	8-37
Throttle lever	<ul style="list-style-type: none"> ● Make sure that operation is smooth. Lubricate cable and lever housing if necessary. ● Check cable free play, and adjust if necessary. 	5-5, 8-30
Control cables	<ul style="list-style-type: none"> ● Make sure that operation is smooth. Lubricate if necessary. 	8-41
Drive chain	<ul style="list-style-type: none"> ● Check chain slack, and adjust if necessary. ● Check chain condition. Lubricate if necessary. 	5-5, 8-38, 8-40
Wheels and tires	<ul style="list-style-type: none"> ● Check wheel condition, and replace if damaged. ● Check tire condition and tread depth. Replace if necessary. ● Check air pressure. Correct if necessary. 	5-6, 5-7, 5-7
Brake and shift pedals	<ul style="list-style-type: none"> ● Make sure that operation is smooth. Lubricate pedal pivoting points if necessary. 	8-42
Brake and clutch levers	<ul style="list-style-type: none"> ● Make sure that operation is smooth. Lubricate lever pivoting points if necessary. 	8-42
Chassis fasteners	<ul style="list-style-type: none"> ● Make sure that all nuts, bolts and screws are properly tightened. 	5-8
Instruments, lights and switches	<ul style="list-style-type: none"> ● Check operation, and correct if necessary. 	5-8

 WARNING

Always inspect your ATV each time you use it to make sure it is in safe operating condition. Always follow the inspection and maintenance procedures and schedules described in the Owner's Manual. Failure to inspect increases the possibility of an accident or equipment damage.

EBU19550

Fuel and 2-stroke engine oil mixing ratio

<p>Recommended 2-stroke engine oil: Yamalube “R” (Yamalube Racing 2-cycle oil) Mixing ratio: 24:1</p>

5

If Yamalube “R” oil is not available, select an oil from the following list.

Recommended 2-stroke engine oil	Mixing ratio
Castrol R30	20:1
Castrol A545	
Castrol A747	

ECB00140

CAUTION:

Never mix two types of 2-stroke engine oil in the same batch. Always use the same type of oil to ensure maximum engine performance.

EBU19580

Transmission oil

Make sure that the transmission oil is at the specified level. Add oil as necessary. (See page 8-9.)

EBU19630

Coolant

Make sure that the coolant is at the specified level. Add coolant as necessary. (See page 8-11.)

NOTE:

The coolant level must be checked on a cold engine since the level varies with engine temperature.

EWB00510

WARNING

Wait for the engine and radiator to cool before removing the radiator cap. You could be burned by hot fluid and steam blown out under pressure. Always put a thick rag over the cap when opening. Allow any remaining pressure to escape before completely removing the cap.

EBU19710

Front and rear brakes

Brake lever and brake pedal

- Check that there is no free play in the brake lever. If there is free play, have a Yamaha dealer check the brake system.
- Check for correct brake pedal height. (See

page 8-34.) If the pedal height is incorrect, have a Yamaha dealer adjust it.

- Check the operation of the lever and pedal. They should move smoothly and there should be a firm feeling when the brakes are applied. If not, have a Yamaha dealer check the brake system.

Brake fluid level

Check the brake fluid level. Add fluid if necessary. (See page 8-32.)

Recommended brake fluid: DOT 4

Brake fluid leakage

Check to see if any brake fluid is leaking out of the pipe joints or brake fluid reservoirs. Apply the brakes firmly for one minute. If there is any leakage, have a Yamaha dealer check the brake system.

Brake operation

Test the brakes at slow speed after starting out to make sure they are working properly. If the brakes do not provide proper braking performance, check the brake pads for wear. (See page 8-31.)

EWB00580



Always check the brakes at the start of every ride. Do not ride the ATV if you find any problem with the brakes or you could lose braking ability, which could lead to an accident. If a problem cannot be corrected by the adjustment procedures provided in this manual, have a Yamaha dealer check for the cause.

EBU19761

Throttle lever

Check the operation of the throttle lever. It must open smoothly and spring back to the idle position when released. Have a Yamaha dealer correct if necessary.

EBU19770

Drive chain

Check the condition of the drive chain and check the drive chain slack. Lubricate and adjust the drive chain as necessary. (See page 8-38.)

⚠ WARNING

Use of improper tires on this ATV, or operation of this ATV with improper or uneven tire pressure, may cause loss of control, increasing your risk of accident.

Pay attention to the following.

- The tires listed below have been approved by Yamaha Motor Co., Ltd. for this model. Other tire combinations are not recommended.

Front:

Manufacturer/model:

DUNLOP/KT851B

Size:

AT21 x 7-10

Type:

Tubeless

Rear:

Manufacturer/model:

DUNLOP/KT877A

Size:

AT20 x 10-9

Type:

Tubeless

- The tires should be set to the recommended pressure:

Recommended tire pressure:

Front:

30.0 kPa (4.4 psi) (0.300 kgf/cm²)

Rear:

30.0 kPa (4.4 psi) (0.300 kgf/cm²)

- Check and adjust tire pressures when the tires are cold.
- Tire pressures must be equal on both sides.
- Tire pressure below the minimum specified could cause the tire to dislodge from the rim under severe riding conditions.

Minimum tire pressure:

Front:

27.0 kPa (3.9 psi) (0.270 kgf/cm²)

Rear:

27.0 kPa (3.9 psi) (0.270 kgf/cm²)

- Use no more than the following pressures when seating the tire beads.

Maximum tire seating pressure:

Front:

250 kPa (36 psi) (2.5 kgf/cm²)

Rear:

250 kPa (36 psi) (2.5 kgf/cm²)

Higher pressures and fast inflation may cause a tire to burst. Inflate the tires very slowly and carefully.

EBU19820

Measuring the tire pressure

Use the low-pressure tire gauge.

NOTE:

The low-pressure tire gauge is included as standard equipment. Make two measurements of the tire pressure and use the second reading. Dust or dirt in the gauge could cause the first reading to be incorrect.

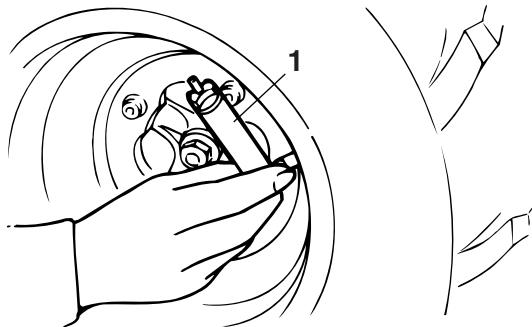

1. Low-pressure tire gauge

Set the tire pressure when the tires are cold. Set the tire pressures to the following specifications:

Recommended pressure:

Front

30.0 kPa (4.4 psi) (0.300 kgf/cm²)

Rear

30.0 kPa (4.4 psi) (0.300 kgf/cm²)

Minimum:

Front

27.0 kPa (3.9 psi) (0.270 kgf/cm²)

Rear

27.0 kPa (3.9 psi) (0.270 kgf/cm²)

Maximum:

Front

33.0 kPa (4.8 psi) (0.330 kgf/cm²)

Rear

33.0 kPa (4.8 psi) (0.330 kgf/cm²)

EBU19830

Tire wear limit

Replace the tire when the tire groove decreases to 3 mm (0.12 in).

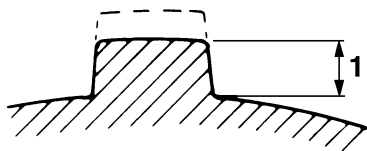

5

1. Tire wear limit

EBU19840

Chassis fasteners

Make sure that all nuts, bolts and screws are properly tightened.

EBU19850

Instruments, lights and switches

Check that all instruments, lights and switches are working properly. Correct if necessary.

OPERATION

Read the Owner's Manual carefully before riding the ATV.

WARNING

Read the Owner's Manual carefully to become familiar with all controls in order to help prevent any loss of control, which could cause an accident or injury. If there is a control or function you do not understand, ask your Yamaha dealer.

Starting a cold engine

WARNING

Always make sure all control cables work smoothly before you begin riding in cold weather. If the control cables are frozen or do not work smoothly, you could be unable to control the ATV, which could lead to an accident or collision.

CAUTION:

See the "Engine break-in" section on page 6-4 prior to operating the engine for the first time.

1. Set the parking brake.
2. Turn the fuel cock to "ON".
3. Turn the main switch to "ON" and the engine stop switch to "RUN".
4. Shift the transmission into neutral.
5. Use the starter (choke) in reference to the figure:

Position (1):

- Cold engine start with ambient temperature below 5 °C (40 °F).

Position (2):

- Cold engine start with ambient temperature between 0 °C (30 °F) and 30 °C (90 °F).

Position (3):

- Cold engine start with ambient temperature above 25 °C (80 °F).

Ambient temp./starter (choke) position

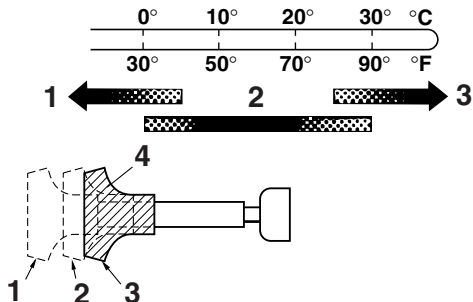

6

1. Fully open
 2. Half open
 3. Closed
 4. Starter (choke)
6. Completely close the throttle lever and start the engine by kicking the kickstarter.
 7. If the engine is started with the starter (choke) in position (1), the starter (choke) should be returned to position (2) to warm up the engine. If the engine is started with the starter (choke) in position (2), keep the starter (choke) in this position to warm up the engine.

ECB00160

CAUTION:

For maximum engine life, always warm the engine up before starting off. Never accelerate hard when the engine is cold!

8. Continue warming up the engine until it idles smoothly, then return the starter (choke) to position (3) before riding.

NOTE:

- The engine is warm when it responds normally to the throttle with the starter (choke) turned off.
- When the parking brake is applied, engine speed is limited to 2300 r/min. Make sure the parking brake is released before moving the throttle lever, otherwise the engine will misfire, preventing normal operation.

EBU20291

Starting a warm engine

Follow the same procedure as for starting a cold engine, with the exception that the starter (choke) is not required when the engine is warm. Instead, start the engine with the throttle slightly open.

Shifting

This ATV has a 6-speed forward transmission. The transmission allows you to control the amount of power you have available at a given speed or for starting, accelerating, climbing hills, etc.

To shift into neutral, return the throttle lever to the closed position, apply the clutch, and then repeatedly depress the shift pedal until it stops.

When it stops, it will be in first gear. Raise the pedal slightly to reach the neutral position.

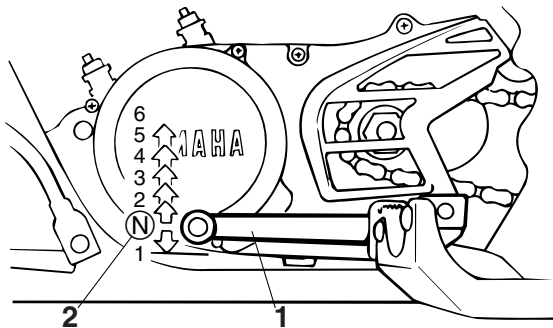

1. Shift pedal
2. Neutral position

To start out and accelerate

1. Release the throttle lever.

CAUTION:

Always close the throttle before shifting gears, otherwise damage to the engine and drive train may result.

2. Pull the clutch lever to disengage the clutch.
3. Shift into first gear.
4. Open the throttle gradually and at the same time, release the clutch lever slowly.
5. Once the ATV has attained adequate speed, release the throttle, and at the same time, quickly pull in the clutch lever.
6. Shift the transmission into second gear. (Make sure not to shift the transmission into neutral)
7. Open the throttle part way and gradually release the clutch lever.
8. Follow the same procedure when shifting to the next higher gear.

WARNING

Opening the throttle abruptly or releasing the clutch lever too quickly could make the ATV

wheelie, which would increase the chance of an accident, including an overturn.

EBU20650

To decelerate

When slowing down or stopping, release the throttle and apply the brakes smoothly and evenly. As you slow down, shift to a lower gear. Be sure that the engine has sufficiently slowed before engaging a lower gear. Improper use of the brakes or shifting can cause the tires to lose traction, reducing control and increasing the possibility of an accident.

EWB00710

WARNING

Make sure the engine has sufficiently slowed before shifting to a lower gear. Engaging a lower gear when the engine speed is too high could make the wheels stop rotating and lose traction. This could cause loss of control, an accident and injury. It could also cause engine or drive train damage.

ECB00180

CAUTION:

- **Even with the transmission in the neutral position, do not coast for long periods of time with the engine off, and do not tow the ATV**

for long distances. The transmission is properly lubricated only when the engine is running. Inadequate lubrication may damage the transmission.

- **Always use the clutch when changing gears. The engine, transmission and drive train are not designed to withstand the shock of forced shifting and can be damaged by shifting without using the clutch.**
-

EBU20672

Engine break-in

NOTE:

- For ATVs equipped with an odometer or an hour meter, follow the figures given in km (mi) or the figures given in hours.
 - For ATVs not equipped with an odometer or hour meter, follow the figures given in hours.
-

There is never a more important period in the life of your engine than the first 320 km (200 mi) or 20 hours of riding. For this reason, you should read the following material carefully.

Since the engine is brand new, do not put an excessive load on it for the first 320 km (200 mi) or 20 hours. The various parts in the engine wear and

polish themselves to the correct operating clearances. During this period, prolonged full-throttle operation or any condition that might result in engine overheating must be avoided.

0–160 km (0–100 mi) or 0–10 hours

Avoid prolonged operation above 1/2 throttle. Vary the speed of the ATV regularly. Do not operate it at one set throttle position.

160–320 km (100–200 mi) or 10–20 hours

Avoid prolonged operation above 3/4 throttle. Rev the engine through the gears freely, but do not use full throttle at any time.

320 km (200 mi) or 20 hours and beyond

The ATV can now be operated normally.

ECB00220

CAUTION:

If any engine trouble should occur during the engine break-in period, immediately have a Yamaha dealer check the ATV.

EBU20721

Parking

When parking the ATV, stop the engine, shift into first gear, apply the parking brake, and then turn

the fuel cock to “OFF”.

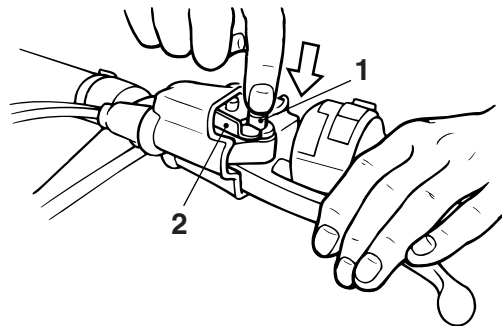

1. Button
2. Parking brake lock plate

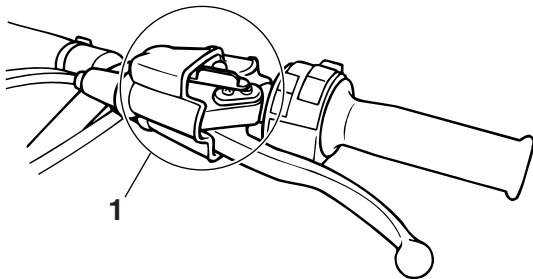

6

1. Locked position

EBU20860

Parking on a slope

EWB00850

WARNING

Avoid parking on hills or other inclines. Parking on a hill or other incline could cause the ATV to roll out of control, increasing the chance of an accident. If you must park on an incline, place the ATV transversely across the incline, shift into first gear, stop the engine, apply the parking brake, and then block the front and rear wheels with rocks or other objects. Do not park the ATV at all on hills that are so

steep you could not walk up them easily.

1. Bring the ATV to a stop by applying the brakes in first gear.
2. Stop the engine and release the clutch lever.
3. With the rear brake applied, apply the parking brake and slowly release the brake pedal.

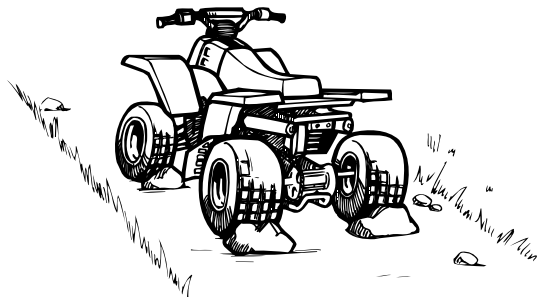

EBU20910

Accessories and loading

EBU20920

Accessories

Accessories can affect the handling and control of your ATV. Keep the following in mind when considering an accessory or operating an ATV which has accessories.

- Choose only accessories designed for your ATV. Your Yamaha dealer has a variety of genuine Yamaha accessories. Other accessories may also be available on the market. However, it is not possible for Yamaha to test all non-Yamaha accessories, nor control over their quality or suitability. Choose a genuine Yamaha accessory, or one that is equivalent in design and quality.
- Accessories should be rigidly and securely mounted. An accessory which can shift position or come off while you are riding could affect your ability to control the ATV.
- Do not mount an accessory where it could interfere with your ability to control the ATV. Examples include (but are not limited to) a heavy or bulky object attached to the handlebars which could make steering difficult, an accessory that limits your ability to move around on the seat, or one that limits your view.
- Use extra caution when riding an ATV with accessories. The ATV may handle differently than it does without accessories.

EBU20940

Loading

As originally equipped, this ATV is not designed to

carry cargo or tow a trailer. If you choose to add accessories so that you can carry cargo or tow a trailer, you must use common sense and good judgment as the stability and handling of an ATV can be changed. When adding accessories, keep the following points in mind:

- Never exceed the weight limits shown. An overloaded ATV can be unstable.

MAXIMUM LOADING LIMIT

ATV loading limit (total weight of rider, cargo, accessories, and tongue):

100.0 kg (220 lb)

- If you are carrying cargo and towing a trailer, include the tongue weight in the maximum ATV load limit.
- Load cargo on the carriers as close to the center of the ATV as possible. Put cargo at the rear of the front carrier, at the front of the rear carrier, and center it.
- Tie down cargo securely to the carriers. Make sure cargo in the trailer cannot move around. A shifting load can cause an accident.
- Make sure the load does not interfere with controls or your ability to see where you are going.
- Ride more slowly than you would without a load.

The more weight you carry, the slower you should go. Although conditions vary, it is good practice not to exceed 2nd gear whenever you are carrying heavier loads or when towing a trailer.

- Allow more braking distance. A heavier ATV takes longer to stop.
- Avoid making sharp turns unless at very slow speeds.
- Avoid hills and rough terrain. Choose terrain carefully. Added weight affects the stability and handling of the ATV.

6

EWB00820

 **WARNING**

Never exceed the stated load capacity for this ATV. Overloading this ATV or carrying or towing cargo improperly could cause changes in ATV handling which could lead to an accident. Cargo should be properly distributed and securely attached. Reduce speed when carrying cargo or pulling a trailer. Allow greater distance for braking.

RIDING YOUR ATV

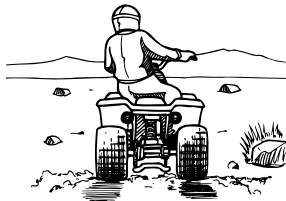
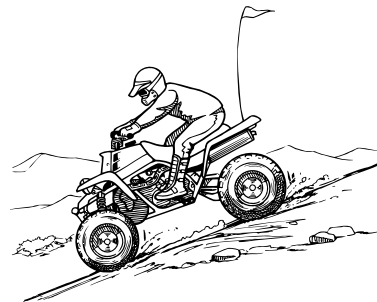

GETTING TO KNOW YOUR ATV

This ATV is intended for recreational use by experienced operators only. Even if you are an experienced operator of all other all terrain ATVs or motorcycles, riding the ATV requires special skills acquired through practice. Take your time to fully learn techniques before attempting more difficult maneuvers.

Riding your new ATV can be a very enjoyable activity, providing you with hours of pleasure. But it is essential to familiarize yourself with the operation of the ATV to achieve the skill necessary to enjoy riding safely. Before you begin to ride, be sure you have read this Owner's Manual completely and understand the operation of the controls. Pay particular attention to the safety information on pages 1-1–1-4. Please also read all caution and warning labels on your ATV.

RIDE WITH CARE AND GOOD JUDGEMENT

Get training if you are inexperienced.

Beginners should get training from a certified instructor.

Become familiar with this ATV at slow speeds first, even if you are an experienced operator. Do not attempt to operate at maximum performance until you are totally familiar with the ATV's handling and performance characteristics.

EWB01380

WARNING

Never operate this ATV without proper instruction. Beginning and inexperienced operators should regularly practice the skills and the operating techniques described in this Owner's Manual. The risk of an accident is greatly increased if the operator does not know how to operate the ATV properly in different situations and on different types of terrain.

Riding your ATV requires skills acquired through practice over a period of time.

Take the time to learn the basic techniques well before attempting more difficult maneuvers.

Not recommended for children under 16 years of age.

EWB01390

WARNING

A child under 16 should never operate an ATV

with engine size greater than 90 cc. Use by children of ATVs that are not recommended for their age can lead to severe injury or death of the child.



This ATV is designed to carry operator only – passengers prohibited.

EWB01400

⚠ WARNING

Never carry a passenger. The long seat is to allow the operator to shift position as needed during operation. It is not for carrying passengers. Carrying a passenger on this ATV greatly reduces your ability to balance and control this ATV. It could cause an accident, resulting in

harm to you and/or your passenger.

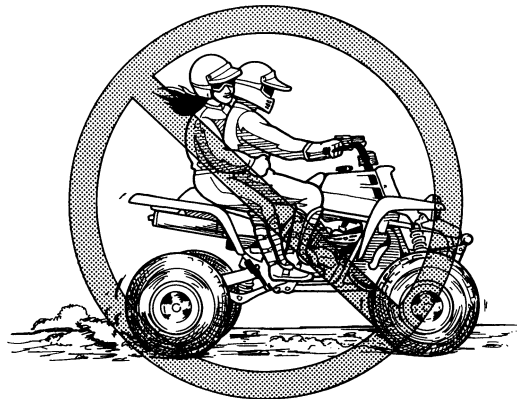

Apparel

Always wear an approved motorcycle helmet that fits properly.

You should also wear:

- eye protection (goggles or face shield)
- gloves
- boots
- long-sleeved shirt or jacket
- long pants

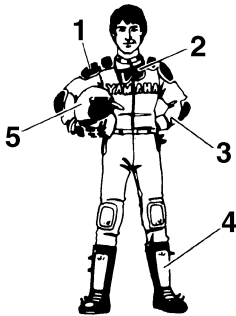

1. Protective clothing
2. Goggles
3. Gloves
4. Boots
5. Helmet

7

EWB01410

⚠ WARNING

Never operate this ATV without wearing an approved motorcycle helmet, eye protection and protective clothing. Operating without an approved motorcycle helmet increases your chances of a severe head injury or death in the event of an accident. Operating without eye protection can result in an accident and increases your chances of a severe injury in the

event of an accident. Operating without protective clothing increases your chances of severe injury in the event of an accident.

Do not operate after consuming alcohol or drugs.

The operator's performance capability is reduced by the influence of alcohol or drugs.



EWB01420

⚠ WARNING

Never consume alcohol or drugs before or while driving this ATV.

Pre-operation checks

Always perform the pre-operation checks listed on

page 5-1 before riding for proper care of the ATV and to ensure safety.

EWB01430

WARNING

Always inspect your ATV each time you use it to make sure the ATV is in safe operating condition. Always follow the inspection and maintenance procedures and schedules described in the Owner's Manual. Failure to inspect the ATV before operating or failure to properly maintain the ATV increases the possibility of an accident or equipment damage.

EWB01440

WARNING

Always use the size and type tires specified in the Owner's Manual for this ATV on page 5-6. Always maintain proper tire pressure as described in the Owner's Manual on page 5-7. Use of improper tires on this ATV, or operation of this ATV with improper or uneven tire pressure, may cause loss of control, increasing your risk of an accident.

Do not operate at speeds too fast for your skills or the conditions.

EWB01450

WARNING

Always go at a speed that is proper for the terrain, visibility and operating conditions, and your experience. Operating this ATV at speeds too fast for your skills or the conditions increases your chances of losing control of the ATV, which can result in an accident.

Speed limiter

For riders less experienced with this model, the throttle lever housing is equipped with a speed limiter. The speed limiter keeps the throttle from fully opening, even when the throttle lever is pushed to the maximum. Turning in the adjusting screw limits the maximum engine power available and decreases the maximum speed of the ATV. Turning in the adjusting screw decreases top speed, and turning it out increases top speed. (See page 4-3.)

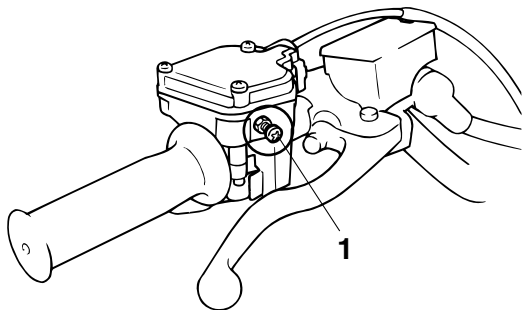

1. Adjusting screw

7 Loading and accessories

As originally equipped, this ATV is not designed to carry cargo or tow a trailer. If you choose to add accessories so that you can carry cargo or tow a trailer, you must use common sense and good judgment.

Use extra caution when riding the ATV with additional loads, such as accessories or cargo. The ATV's handling may be adversely affected. Reduce your speed when adding additional loads.

MAXIMUM LOADING LIMIT

ATV loading limit (total weight of cargo, rider, accessories, and tongue):
100.0 kg (220 lb)

EWB01460

⚠ WARNING

- **Never exceed the stated load capacity for this ATV.**
- **Cargo should be properly distributed and securely attached.**
- **Reduce speed when carrying cargo or pulling a trailer. Allow greater distance for braking.**
- **Always follow the instructions in your Owner's Manual for carrying cargo or pulling a trailer.**

During operation

Always keep your feet on the footboards during operation, otherwise they may contact the rear wheels.

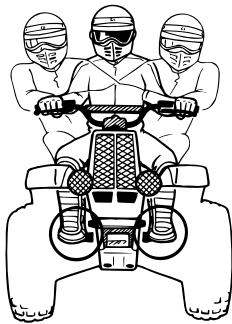

EWB01470

⚠ WARNING

Always keep both hands on the handlebars and both feet on the footboards of your ATV during operation. Removing even one hand or foot can reduce your ability to control the ATV or could cause you to lose your balance and fall off of the ATV. If you remove a foot from a footboard, your foot or leg may come into contact with the rear wheels, which could injure you or cause an accident.

Avoid wheelies and jumping. You may lose control of the ATV or overturn.

EWB01480

⚠ WARNING

Never attempt stunts, such as wheelies or jumps. Don't try to show off.

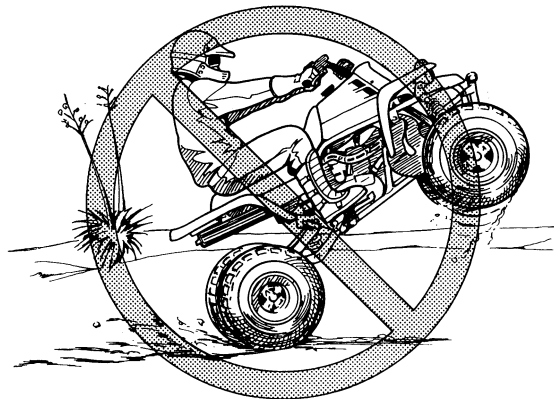

Modifications

EWB01490

⚠ WARNING

Never modify this ATV through improper installation or use of accessories. All parts and accessories added to this ATV should be genuine Yamaha or equivalent components designed for use on this ATV and should be

installed and used according to instructions. Improper installation of accessories or modification of this ATV may cause changes in handling which in some situations could lead to an accident. If you have questions, consult an authorized ATV dealer.

Exhaust system

The exhaust system on the ATV is very hot during and following operation. To prevent burns, avoid touching the exhaust system. Park the ATV in a place where pedestrians or children are not likely to touch it. Also, avoid parking in or around dry grass, brush or other combustible materials to prevent causing a fire hazard.

EWB01500

WARNING

- Do not touch the hot exhaust system.
 - Do not park the ATV during or after operation in a place where others might be likely to touch it.
 - Do not operate, idle, or park the ATV in dry grass, dry ground cover, or combustible materials.
-

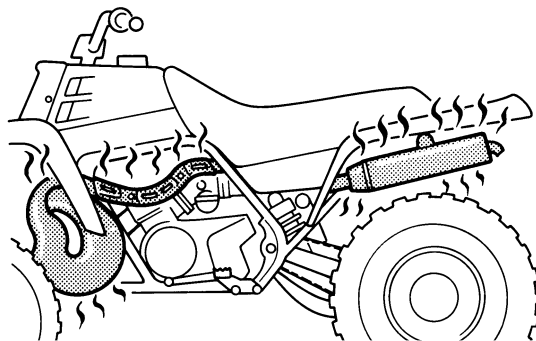

BE CAREFUL WHERE YOU RIDE

This ATV is designed for use on unpaved surfaces only. Riding on paved surfaces can cause loss of control.

EWB01510

WARNING

Always avoid paved surfaces, including sidewalks, driveways, parking lots and streets. ATVs are designed for use on unpaved surfaces only. Paved surfaces may seriously affect handling and control of the ATV, and may cause the ATV to go out of control.

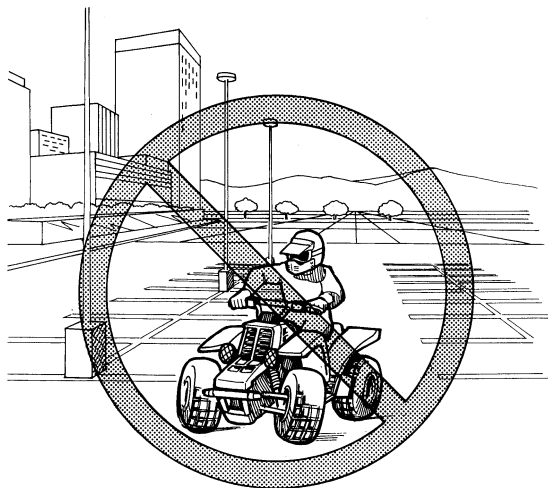

While riding on unpaved public streets or roads may be legal in your area, such operation can increase the risk of collision with other vehicles. Watch carefully for other vehicles. Make sure you know your country's laws and regulations before you ride on unpaved public streets or roads. Do not ride on any paved public street, road or motorway.

EWB01520

⚠ WARNING

Never operate this ATV on any paved street,

paved road or motorway. You can collide with another vehicle. In many areas, it is illegal to operate ATVs on public streets, roads and highways.

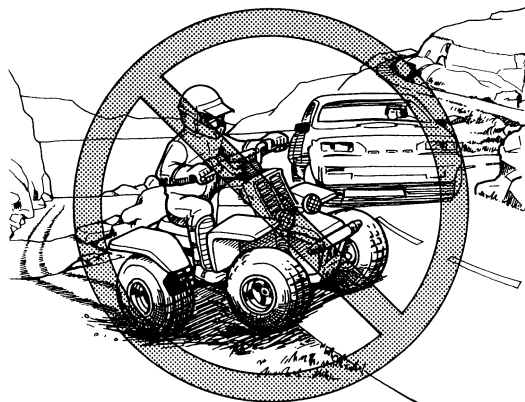

Know the terrain where you ride. Ride cautiously in unfamiliar areas. Stay alert for **holes, rocks, or roots** in the terrain, and **other hidden hazards** which may cause the ATV to upset.

EWB01530

⚠ WARNING

Go slowly and be extra careful when operating on unfamiliar terrain. Always be alert to chang-

ing terrain conditions when operating the ATV.

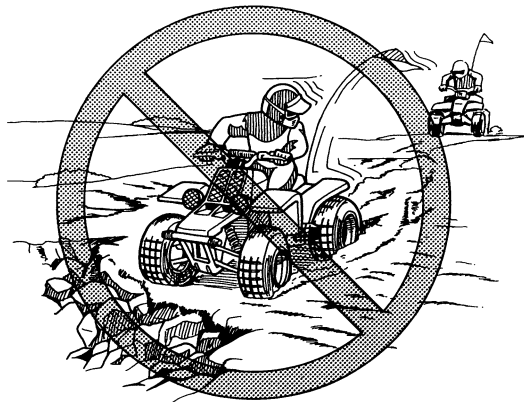

7

EWB01540

⚠ WARNING

Do not operate on excessively rough, slippery or loose terrain until you have learned and practiced the skills necessary to control the ATV on such terrain. Failure to use extra care when operating on excessively rough, slippery or loose terrain could cause loss of traction or ATV control, which could result in an accident, including an overturn.

When riding in an area where you might not easily be seen, such as desert terrain, mount a caution flag on the ATV. **DO NOT** use the flag pole bracket as a trailer hitch.



EWB01550

⚠ WARNING

Always mount a caution flag on the ATV to make you more visible when operating in areas where you might not be seen by other vehicles. Watch carefully for other vehicles.

Do not ride in areas posted “no trespassing”.
Do not ride on private property without getting permission.

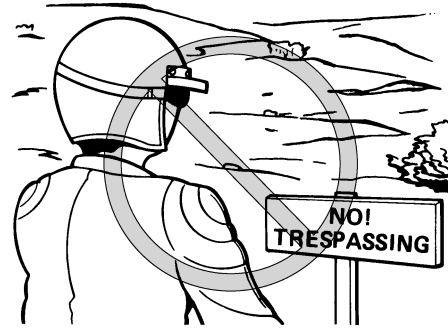

Select a large, flat, unpaved area to become familiar with your ATV. Make sure that this area is free of obstacles and other riders. You should practice control of the throttle, brakes, shifting procedures, and turning techniques in this area before trying more difficult terrain. Always avoid riding on paved surfaces: the ATV is designed for use on unpaved surfaces only, and handling maneuvers are more difficult to perform on pavement.

Set the parking brake and follow the instruction on page 6-1 to start the engine. Once it has warmed up you are ready to begin riding your ATV. As you get on the ATV, be sure not to accidentally move the shift pedal. Remember that the engine and exhaust pipe will be hot when riding and afterwards; do not allow skin or clothing to come in contact with

these components.

With the engine idling, pull the clutch lever to disengage the clutch and shift into 1st gear, and then release the parking brake. Open the throttle gradually, and at the same time, release the clutch lever slowly. Once the ATV has attained adequate speed, release the throttle lever and at the same time, quickly pull in the clutch lever and shift into 2nd gear. Open the throttle part way and gradually release the clutch. Use this same procedure as you move into the higher gears. Be sure to coordinate the use of the throttle and shift pedal properly. If the throttle is applied too abruptly or if the throttle is not released during shifting, or if the shift pedal is not released before applying the throttle, the front wheels may lift off the ground, resulting in a loss of directional control. Avoid higher speeds until you are thoroughly familiar with the operation of your ATV.

EWB01720

WARNING

Always open the throttle gradually and release the clutch lever slowly. Otherwise, the ATV could wheelie which would increase the chance of an accident.

ECB00230

CAUTION:

Do not shift gears without releasing the throttle. Damage to the engine or drive train may occur.

When slowing down or stopping, release the throttle and apply the brakes smoothly and evenly. As you slow down, shift to a lower gear. Be sure that the engine has sufficiently slowed before engaging a lower gear. Improper use of the brakes or shifting can cause the tires to lose traction, reducing control and increasing the possibility of an accident.

EWB01560

WARNING

Make sure the engine has sufficiently slowed before shifting to a lower gear. Engaging a lower gear when the engine speed is too high could cause the wheels to stop rotating.

TURNING YOUR ATV

To achieve maximum traction on unpaved surfaces, the two rear wheels are mounted solidly on one axle and turn together at the same speed. Therefore, unless the wheel on the inside of the turn is allowed to slip or lose some traction, the ATV will resist turning. A special turning technique must be

used to allow the ATV to make turns quickly and easily. It is essential that this skill be learned first at low speed.

EWB01570

WARNING

Always follow proper procedures for turning as described in this Owner's Manual. Practice turning at low speeds before attempting to turn at faster speeds. Do not turn at speeds too fast for your skills or the conditions.

As you approach a curve, slow down and begin to turn the handlebars in the desired direction. As you do so, put your weight on the footboard to the outside of the turn (opposite your desired direction) and lean your upper body into the turn. Use the throttle to maintain an even speed through the turn. This maneuver will let the wheel on the inside of the turn slip slightly, allowing the ATV to make the turn properly.

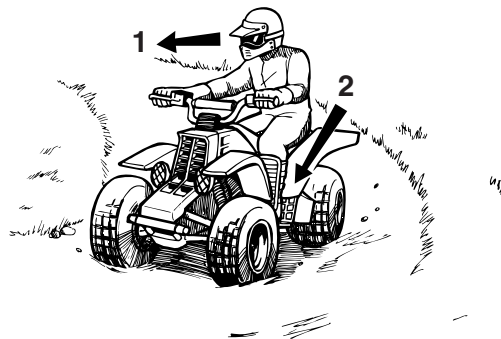

1. Lean towards inside of turn.
2. Support your weight on the outer footrest.

This procedure should be practiced at slow speed many times in a large unpaved area with no obstacles. If an incorrect technique is used, your ATV may continue to go straight. If the ATV doesn't turn, come to a stop and then practice the procedure again. If the riding surface is slippery or loose, it may help to position more of your weight over the front wheels by moving forward on the seat. Once you have learned this technique, you should be able to perform it at higher speeds or in tighter curves.

Improper riding procedures such as abrupt throttle

changes, excessive braking, incorrect body movements, or too much speed for the sharpness of the turn may cause the ATV to tip. If the ATV begins to tip over to the outside while negotiating a turn, lean more to the inside. It may also be necessary to gradually let off on the throttle and steer to the outside of the turn to avoid tipping over.

Remember: Avoid higher speeds until you are thoroughly familiar with the operation of your ATV.

CLIMBING UPHILL

Use proper riding techniques to avoid ATV overturns on hills. Be sure that you can maneuver your ATV well on flat ground before attempting any incline and then practice riding first on gentle slopes. Try more difficult climbs only after you have developed your skill. In all cases avoid inclines with slippery or loose surfaces, or obstacles that might cause you to lose control.

EWB01580

WARNING

Never operate the ATV on hills too steep for the ATV or for your abilities. The ATV can overturn more easily on extremely steep hills than on level surfaces or small hills. Practice on smaller hills before attempting large hills.

It is important when climbing a hill to make sure that your weight is transferred forward on the ATV. This can be accomplished by leaning forward and, on steeper inclines, standing on the footboards and leaning forward over the handlebars.

EWB01590

WARNING

- **Always follow proper procedures for climbing hills as described in this Owner's Manual.**
 - **Always check the terrain carefully before you start up any hill.**
 - **Never climb hills with excessively slippery or loose surfaces.**
 - **Shift your weight forward.**
 - **Never open the throttle suddenly or make sudden gear changes. The ATV could flip over backwards.**
 - **Never go over the top of any hill at high speed. An obstacle, a sharp drop, or another vehicle or person could be on the other side of the hill.**
-

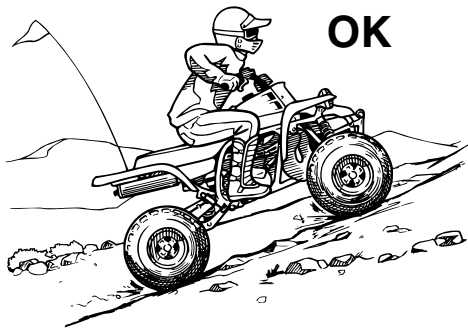

If you are climbing a hill and you find that you have not properly judged your ability to make it to the top, you should turn the ATV around while you still have forward motion (provided you have the room to do so) and go down the hill.

EWB01600

⚠ WARNING

Never attempt to turn the ATV around on any hill until you have mastered the turning technique as described in the Owner's Manual on level ground. Be very careful when turning on any hill. Avoid crossing the side of a steep hill if possible.

When crossing the side of a hill:

- Always follow proper procedures as de-

- scribed in the Owner's Manual.
 - Avoid hills with excessively slippery or loose surfaces.
 - Shift your weight to the uphill side of the ATV.
-

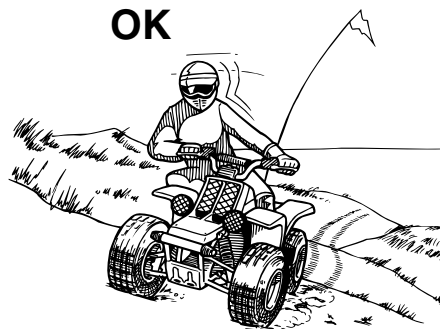

If your ATV has stalled or stopped and you believe you can continue up the hill, restart carefully to make sure you do not lift the front wheels which could cause you to lose control. If you are unable to continue up the hill, dismount the ATV on the uphill side. Physically turn the ATV around and then descend the hill.

If you start to roll backwards, **DO NOT** apply the rear brake to stop or try to put the ATV in gear. The ATV could easily tip over backwards. Instead, ap-

ply the front brake gradually, or dismount the ATV immediately on the uphill side.

EWB01731

⚠ WARNING

Use the proper gear and maintain a steady speed when climbing a hill.

If you lose all forward speed:

- Keep weight uphill.
- Apply the brakes.
- Lock the parking brake after you are stopped.

If you begin rolling backwards:

- Keep weight uphill.
- Never apply the rear brake while rolling backwards. Apply the front brake.
- When fully stopped, apply the rear brake as well, and then lock the parking brake.

Dismount on uphill side or to a side if pointed straight uphill. Turn the ATV around and re-mount, following the procedure described in the Owner's Manual.

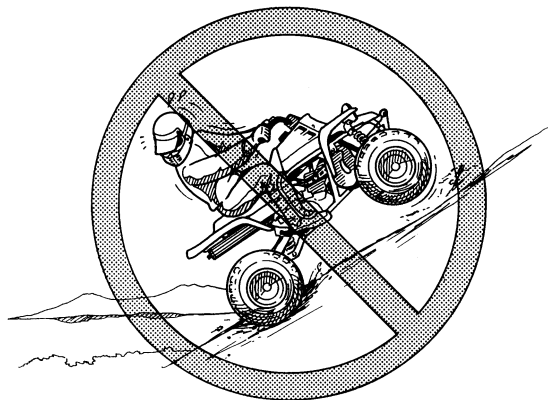

RIDING DOWNHILL

When riding your ATV downhill, shift your weight as far to the rear and uphill side of the ATV as possible. Move back on the seat and sit with your arms straight. Choose a low gear which will allow the engine compression to do most of the braking for you. Improper braking may cause a loss of traction.

Use caution while descending a hill with loose or slippery surfaces. Braking ability and traction may be adversely affected by these surfaces. Improper braking may also cause a loss of traction.

Whenever possible, ride your ATV straight down-

hill. Avoid sharp angles which could allow the ATV to tip or roll over. Carefully choose your path and ride no faster than you will be able to react to obstacles which may appear.

EWB01620

WARNING

Always follow proper procedures for going down hills as described in this Owner's Manual.

Note: a special technique is required when braking as you go down a hill.

- Always check the terrain carefully before you start down any hill.
- Shift your weight backward.
- Never go down a hill at high speed.
- Avoid going down a hill at an angle that would cause the ATV to lean sharply to one side. Go straight down the hill where possible.

OK

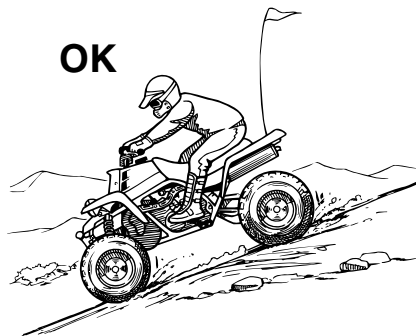

CROSSING A SLOPE

Traversing a sloping surface on your ATV requires you to properly position your weight to maintain proper balance. Be sure that you have learned the basic riding skills on flat ground before attempting to cross a sloping surface. Avoid slopes with slippery surfaces or rough terrain that may upset your balance.

As you travel across a slope, lean your body in the uphill direction. It may be necessary to correct the steering when riding on loose surfaces by pointing the front wheels slightly uphill. When riding on slopes, be sure not to make sharp turns either up or down hill.

If your ATV does begin to tip over, gradually steer

in the downhill direction if there are no obstacles in your path. As you regain proper balance, gradually steer again in the direction you wish to travel.

EWB01631

⚠ WARNING

Never attempt to turn the ATV around on any hill until you have mastered the turning technique as described in the Owner's Manual on level ground. Be very careful when turning on any hill. Avoid crossing the side of a steep hill if possible.

When crossing the side of a hill:

- Always follow proper procedures as described in the Owner's Manual.
- Avoid hills with excessively slippery or loose surfaces.
- Shift your weight to the uphill side of the ATV.



CROSSING THROUGH SHALLOW WATER

The ATV can be used to cross slow moving, shallow water of up to a maximum of 35 cm (14 in) in depth. Before entering the water, choose your path carefully. Enter where there is no sharp drop off, and avoid rocks or other obstacles which may be slippery or upset the ATV. Drive slowly and carefully.

EWB01640

⚠ WARNING

Never operate this ATV in fast flowing water or in water deeper than that specified in your Owner's Manual. Remember that wet brakes may have reduced stopping ability. Test your brakes after leaving water. If necessary, apply

them several times to let friction dry out the linings. If the ATV is operated through deep or fast flowing water, the tires may float, causing loss of traction and loss of control, which could lead to an accident.

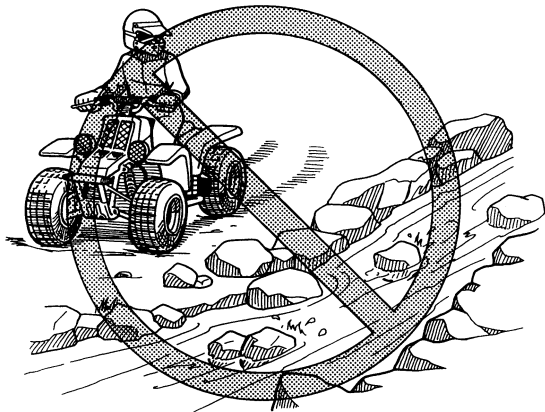

Test your brakes after leaving the water. Do not continue to ride your ATV without verifying that you have regained proper braking ability.

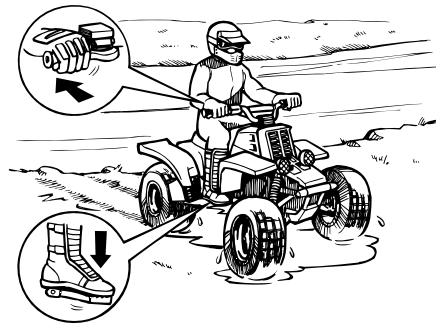

ECB00240

CAUTION:

After riding your ATV in water, be sure to drain the trapped water by removing the check hose at the bottom of the air filter case. Wash the ATV in fresh water if it has been operated in salt water or muddy conditions.

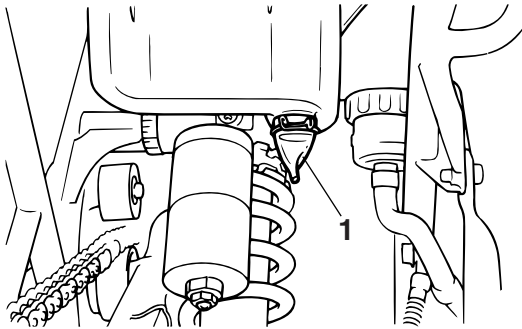

1. Air filter case check hose

7 RIDING OVER ROUGH TERRAIN

Riding over rough terrain should be done with caution. Look out for obstacles which could cause damage to the ATV or could lead to an upset or accident. Be sure to keep your feet firmly mounted on the footboards at all times. Avoid jumping the ATV as loss of control and damage to the ATV may result.

EWB01650

WARNING

Before operating in a new area, check for obstacles. Never attempt to ride over large obstacles, such as large rocks or fallen trees. When

you go over obstacles, always follow proper procedures as described in the Owner's Manual.

SLIDING AND SKIDDING

Care should be used when riding on loose or slippery surfaces since the ATV may slide. If unexpected and uncorrected, sliding could lead to an accident.

To reduce the tendency for the front wheels to slide in loose or slippery conditions, positioning your weight over the front wheels will sometimes help.

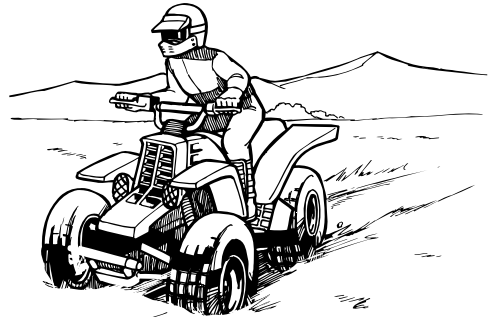

If the rear wheels of your ATV start to slide sideways, control can usually be regained (if there is room to do so) by steering in the direction of the

slide. Applying the brakes or accelerating is not recommended until you have corrected the slide.



With practice, over a period of time, skill at controlled sliding can be developed. The terrain should be chosen carefully before attempting such maneuvers, since both stability and control are reduced. Bear in mind that sliding maneuvers should always be avoided on extremely slippery surfaces such as ice, since all control may be lost.

EWB01661

⚠ WARNING

Learn to safely control skidding or sliding by practicing at low speeds and on level, smooth terrain.

On extremely slippery surfaces, such as ice,

go slowly and be very cautious in order to reduce the chance of skidding or sliding out of control.

WHAT TO DO IF...

This section is designed to be a reference guide only. Be sure to read each section on riding techniques completely.

WHAT TO DO...

- If your ATV doesn't turn when you want it to: Bring the ATV to a stop and practice the turning maneuvers again. Be sure you are putting your weight on the footboard to the outside of the turn. Position your weight over the front wheels for better control. (See page 7-12.)
- If your ATV begins to tip while turning: Lean more into the turn to regain balance. If necessary, gradually let off the throttle and/or steer to the outside of the turn. (See page 7-12.)
- If your ATV starts to slide sideways: Steer in the direction of the slide if you have the room. Applying the brakes or accelerating is not recommended until you have corrected the slide. (See page 7-20.)
- If your ATV can't make it up a hill you are trying

to climb:

Turn the ATV around if you still have forward speed. If not, stop, dismount on the uphill side of the ATV and physically turn the ATV around. If the ATV starts to slip backwards, **DO NOT USE THE REAR BRAKE** – the ATV may tip over on top of you. Dismount the ATV on the uphill side. (See page 7-14.)

- If your ATV is traversing a sloping surface:
Be sure to ride with your weight positioned towards the uphill side of the ATV to maintain proper balance. If the ATV starts to tip, steer down the hill (if there are no obstacles in your way) to regain balance. If you discover that the ATV is going to tip over, dismount on the uphill side. (See page 7-14.)
- If your ATV encounters shallow water:
Ride slowly and carefully through slow moving water, watching for obstacles. Be sure to let water drain from the ATV and **CHECK YOUR BRAKES FOR PROPER OPERATION** when you come out of the water. Do not continue to ride your ATV until you have regained adequate braking ability. (See page 7-18.)

PERIODIC MAINTENANCE AND MINOR REPAIR

Safety is an obligation of the owner. Periodic inspection, adjustment and lubrication will keep your ATV in the safest and best operating condition possible. The most important points of inspection, adjustment, and lubrication are explained on the following pages.

The intervals given in the periodic maintenance and lubrication chart should be considered as a general guide under normal riding conditions. However, **DEPENDING ON THE WEATHER, TERRAIN, GEOGRAPHICAL LOCATION, AND INDIVIDUAL USE, THE MAINTENANCE INTERVALS MAY NEED TO BE SHORTENED.**

EWB01840

WARNING

Never service an engine while it is running. Moving parts can catch clothing or parts of the body, causing injury. Electrical components can cause shocks or start fires. Turn off the engine when performing maintenance unless otherwise specified. Have a Yamaha dealer perform the service if you are not familiar with

maintenance work.

EBU21690

Owner's manual and tool kit

Be sure to put this owner's manual and the low-pressure tire gauge in the plastic bag and always carry them along with the owner's tool kit under the seat.

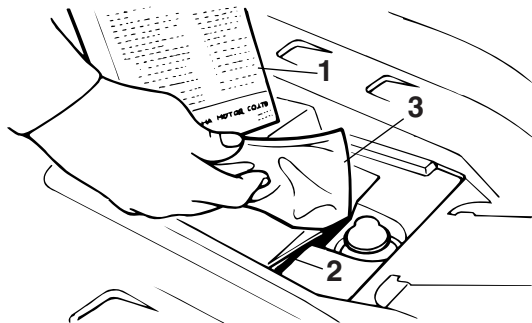

1. Owner's manual
2. Low-pressure tire gauge
3. Owner's tool kit

The service information included in this manual and the tools provided in the owner's tool kit are intended to assist you in the performance of preventive maintenance and minor repairs. However, additional tools such as a torque wrench may be necessary to perform certain maintenance work correctly.

NOTE: _____

If you do not have the tools or experience required for a particular job, have a Yamaha dealer perform it for you.

EWB01850

 **WARNING** _____

Never modify this ATV through improper installation or use of accessories, as it may cause changes in handling, which in some situations could lead to an accident. All parts and accessories added to this ATV should be genuine Yamaha or equivalent components designed for use on this ATV and should be installed and used according to instructions. If you have questions, consult an authorized Yamaha ATV dealer.

Periodic maintenance and lubrication chart

NOTE:

- For ATVs not equipped with an odometer or an hour meter, follow the month maintenance intervals.
- For ATVs equipped with an odometer or an hour meter, follow the km (mi) or hours maintenance intervals. However, keep in mind that if the ATV isn't used for a long period of time, the month maintenance intervals should be followed.
- Items marked with an asterisk should be performed by a Yamaha dealer as they require special tools, data and technical skills.

NO.	ITEM	CHECK OR MAINTENANCE JOB	Whichever comes first ⇒	INITIAL			EVERY		
				month	1	3	6	6	12
				km (mi)	320 (200)	1200 (750)	2400 (1500)	2400 (1500)	4800 (3000)
				hours	20	75	150	150	300
1	*	Fuel line	<ul style="list-style-type: none"> ● Check fuel hoses for cracks or other damage, and replace if necessary. 				√	√	√
2		Spark plugs	<ul style="list-style-type: none"> ● Replace. 	√	√	√	√	√	√
3		Air filter element	<ul style="list-style-type: none"> ● Clean and replace if necessary. 	Every 20–40 hours (more often in wet or dusty areas)					
4	*	Clutch	<ul style="list-style-type: none"> ● Check operation and adjust if necessary. 	√		√	√	√	√
5	*	Front brake	<ul style="list-style-type: none"> ● Check operation and correct if necessary. ● Check fluid level and ATV for fluid leakage, and correct if necessary. 	√	√	√	√	√	√
			<ul style="list-style-type: none"> ● Replace brake pads. 	Whenever worn to the limit					

NO.	ITEM	CHECK OR MAINTENANCE JOB	Whichever comes first ⇒	INITIAL			EVERY		
				month	1	3	6	6	12
				km (mi)	320 (200)	1200 (750)	2400 (1500)	2400 (1500)	4800 (3000)
hours	20	75	150	150	300				
6	* Rear brake	<ul style="list-style-type: none"> • Check operation and correct if necessary. • Check brake pedal free play and adjust if necessary. • Check fluid level and ATV for fluid leakage, and correct if necessary. • Replace brake pads. 		√	√	√	√	√	
				Whenever worn to the limit					
7	* Brake hoses	<ul style="list-style-type: none"> • Check for cracks or other damage, and replace if necessary. • Replace. 			√	√	√	√	
				Every 4 years					
8	* Parking brake	<ul style="list-style-type: none"> • Check operation and adjust if necessary. 		√	√	√	√	√	
9	* Wheels	<ul style="list-style-type: none"> • Check runout and for damage, and replace if necessary. 		√	√	√	√	√	
10	* Tires	<ul style="list-style-type: none"> • Check tread depth and for damage, and replace if necessary. • Check air pressure and balance, and correct if necessary. 		√	√	√	√	√	
11	* Wheel bearings	<ul style="list-style-type: none"> • Check for looseness or damage, and replace if necessary. 		√		√	√	√	
12	* Upper and lower arm pivots	<ul style="list-style-type: none"> • Lubricate with lithium-soap-based grease. 				√	√	√	
13	Drive chain	<ul style="list-style-type: none"> • Check chain slack and adjust if necessary. • Check rear wheel alignment and correct if necessary. • Clean and lubricate. 		√		√	√	√	
14	* Drive chain rollers	<ul style="list-style-type: none"> • Check for wear and replace if necessary. 				√	√	√	

NO.	ITEM	CHECK OR MAINTENANCE JOB	Whichever comes first ⇒	INITIAL			EVERY		
				month	1	3	6	6	12
				km (mi)	320 (200)	1200 (750)	2400 (1500)	2400 (1500)	4800 (3000)
hours	20	75	150	150	300				
15	*	Chassis fasteners	<ul style="list-style-type: none"> • Make sure that all nuts, bolts, and screws are properly tightened. 	√	√	√	√	√	
16	*	Shock absorber assemblies	<ul style="list-style-type: none"> • Check operation and correct if necessary. • Check for oil leakage and replace if necessary. 			√	√	√	
17	*	Steering system	<ul style="list-style-type: none"> • Check operation and repair or replace if damaged. • Check toe-in and adjust if necessary. 	√	√	√	√	√	
18	*	Carburetors	<ul style="list-style-type: none"> • Check starter (choke) operation and correct if necessary. • Check engine idling speed and synchronization, and adjust if necessary. 		√	√	√	√	
19	*	Crankcase breather system	<ul style="list-style-type: none"> • Check breather hose for cracks or other damage, and replace if necessary. 			√	√	√	
20		Transmission oil	<ul style="list-style-type: none"> • Change. • Check ATV for oil leakage, and correct if necessary. 	√		√	√	√	
21		Cooling system	<ul style="list-style-type: none"> • Check coolant level and ATV for coolant leakage, and correct if necessary. 	√	√	√	√	√	
			<ul style="list-style-type: none"> • Replace coolant. 	Every 2 years					
22	*	Moving parts and cables	<ul style="list-style-type: none"> • Lubricate. 		√	√	√	√	
23	*	Throttle lever housing and cable	<ul style="list-style-type: none"> • Check operation and correct if necessary. • Check throttle cable free play and adjust if necessary. • Lubricate throttle lever housing and cable. 	√	√	√	√	√	

NO.	ITEM	CHECK OR MAINTENANCE JOB	Whichever comes first ⇒	INITIAL			EVERY		
				month	1	3	6	6	12
				km (mi)	320 (200)	1200 (750)	2400 (1500)	2400 (1500)	4800 (3000)
				hours	20	75	150	150	300
24	* Exhaust system	<ul style="list-style-type: none"> • Check for leakage and replace gasket(s) if necessary. • Check for looseness and tighten all screw clamps and joints if necessary. 				√	√	√	
25	Spark arrester	<ul style="list-style-type: none"> • Clean. 				√	√	√	
26	* Front and rear brake switches	<ul style="list-style-type: none"> • Check operation and correct if necessary. 		√	√	√	√	√	
27	* Lights and switches	<ul style="list-style-type: none"> • Check operation and correct if necessary. • Adjust headlight beams. 		√	√	√	√	√	

EBU23070

NOTE: _____

- The air filter needs more frequent service if you are riding in unusually wet or dusty areas.
 - Hydraulic brake service
 - Regularly check and, if necessary, correct the brake fluid level.
 - Every two years replace the internal components of the brake master cylinders and calipers, and change the brake fluid.
 - Replace the brake hoses every four years and if cracked or damaged.
-

Checking the spark plugs

The spark plugs are important engine components, which are easy to check. Since heat and deposits will cause any spark plug to slowly erode, the spark plugs should be removed and checked in accordance with the periodic maintenance and lubrication chart. In addition, the condition of the spark plugs can reveal the condition of the engine.

To remove a spark plug

1. Remove the spark plug cap.

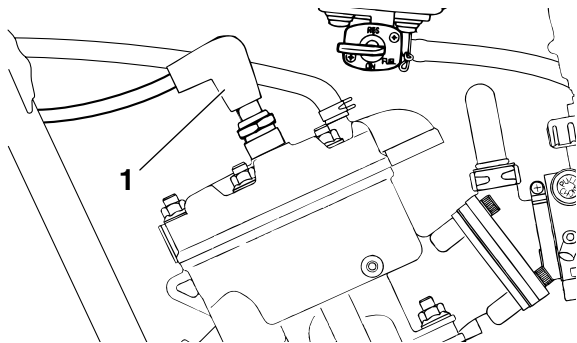

1. Spark plug cap

2. Remove the spark plug as shown, with the spark plug wrench included in the owner's tool

kit.

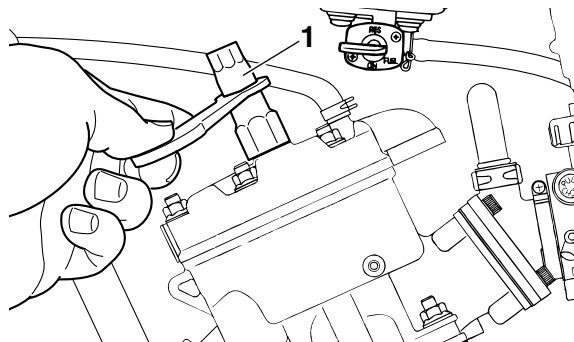

1. Spark plug wrench

To check the spark plugs

1. Check that the porcelain insulator around the center electrode of each spark plug is a medium-to-light tan (the ideal color when the ATV is ridden normally).
2. Check that all spark plugs installed in the engine have the same color.

NOTE:

If any spark plug shows a distinctly different color, the engine could be operating improperly. Do not attempt to diagnose such problems yourself. In-

stead, have a Yamaha dealer check the ATV.

3. Check each spark plug for electrode erosion and excessive carbon or other deposits, and replace it if necessary.

Specified spark plug:
NGK/BR8ES

To install a spark plug

1. Measure the spark plug gap with a wire thickness gauge and, if necessary, adjust the gap to specification.

Spark plug gap:
0.7–0.8 mm (0.028–0.031 in)

8

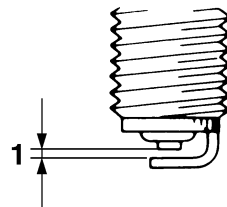

1. Spark plug gap

2. Clean the surface of the spark plug gasket and its mating surface, and then wipe off any grime from the spark plug threads.
3. Install the spark plug with the spark plug wrench, and then tighten it to the specified torque.

Tightening torque:
Spark plug:
20 Nm (2.0 m·kgf, 14 ft·lbf)

NOTE: _____
If a torque wrench is not available when installing

a spark plug, a good estimate of the correct torque is 1/4–1/2 turn past finger tight. However, the spark plug should be tightened to the specified torque as soon as possible.

4. Install the spark plug cap.

EBU23341

Transmission oil

The transmission oil level should be checked before each ride. In addition, the transmission oil must be changed at the intervals specified in the periodic maintenance and lubrication chart.

To check the transmission oil level

1. Place the ATV on a level surface.
2. Start the engine, warm it up for several minutes, and then turn it off.
3. Wait a few minutes until the oil settles, remove the oil filler cap, wipe the dipstick off with a clean rag, insert it back into the oil filler hole (without screwing it in), and then remove it again to check the oil level.

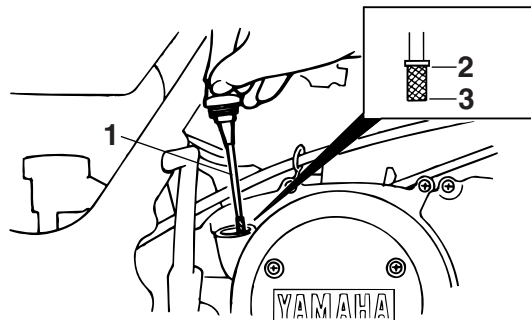

1. Dipstick
2. Maximum level mark
3. Minimum level mark

NOTE:

The transmission oil should be between the minimum and maximum level marks.

4. If the oil is at or below the minimum level mark, add sufficient oil of the recommended type to raise it to the correct level.
5. Insert the dipstick into the oil filler hole, and then tighten the oil filler cap.

To change the transmission oil

1. Place the ATV on a level surface.

2. Start the engine, warm it up for several minutes, and then turn it off.
3. Place an oil pan under the transmission to collect the used oil.
4. Remove the oil filler cap and the drain bolt to drain the oil from the transmission.

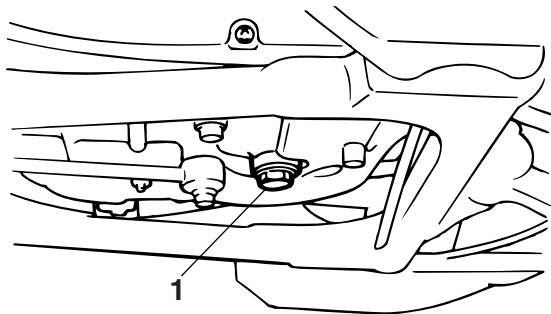

1. Transmission oil drain bolt

5. Install the drain bolt, and then tighten it to the specified torque.

Tightening torque:

Transmission oil drain bolt:

20 Nm (2.0 m·kgf, 14 ft·lbf)

6. Add the specified amount of the recommended transmission oil, and then install and tighten the oil filler cap.

Recommended transmission oil:

See page 10-1.

Oil quantity:

1.5 L (1.59 US qt) (1.32 Imp.qt)

ECB00430

CAUTION:

- In order to prevent clutch slippage (since the transmission oil also lubricates the clutch), do not mix any chemical additives. Do not use oils with a diesel specification of “CD” or oils of a higher quality than specified. In addition, do not use oils labeled “ENERGY CONSERVING II” or higher.
- Make sure that no foreign material enters the crankcase.

7. Start the engine, and then let it idle for several minutes while checking the transmission for oil leakage. If oil is leaking, immediately turn the engine off and check for the cause.
8. Turn the engine off, and then check the oil level and correct it if necessary.

Coolant

The coolant level should be checked before each ride. In addition, the coolant must be changed at the intervals specified in the periodic maintenance and lubrication chart.

To check the coolant level

1. Place the ATV on a level surface.

NOTE: _____

The coolant level must be checked on a cold engine since the level varies with engine temperature.

2. Check the coolant level in the coolant reservoir.

NOTE: _____

The coolant should be between the minimum and maximum level marks.

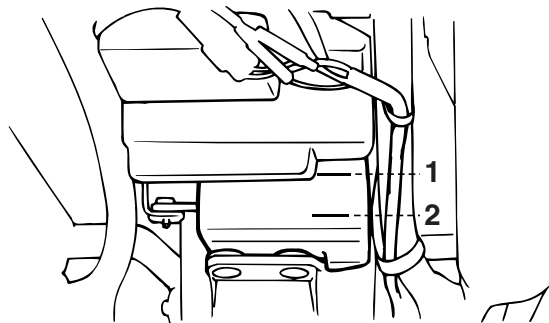

1. Maximum level mark
2. Minimum level mark
3. If the coolant is at or below the minimum level mark, remove the seat. (See page 4-11.)
4. Open the coolant reservoir cover.

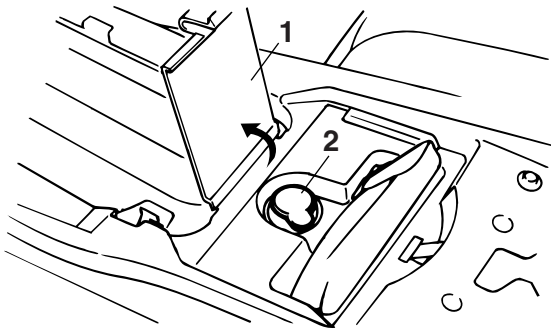

1. Coolant reservoir cover
2. Coolant reservoir cap

8

5. Remove the reservoir cap, add coolant or distilled water to the maximum level mark, and then install the reservoir cap.

Coolant reservoir capacity (up to the maximum level mark):

0.28 L (0.30 US qt) (0.25 Imp.qt)

ECB00401

CAUTION:

- If coolant is not available, use distilled water or soft tap water instead. Do not use hard wa-

ter or salt water since it is harmful to the engine.

- If water has been used instead of coolant, replace it with coolant as soon as possible, otherwise the cooling system will not be protected against frost and corrosion.
- If water has been added to the coolant, have a Yamaha dealer check the antifreeze content of the coolant as soon as possible, otherwise the effectiveness of the coolant will be reduced.

6. Close the coolant reservoir cover.
7. Install the seat.

NOTE:

If the engine overheats, see page 8-51 for further instructions.

EBU23521

To change the coolant

EWB01890

⚠ WARNING

Wait for the engine and radiator to cool before removing the radiator cap. You could be burned by hot fluid and steam blown out under pressure. Always place a thick rag over the cap

when opening. Allow any remaining pressure to escape before completely removing the cap.

1. Place the ATV on a level surface.
2. Remove the radiator cover by removing the bolts.

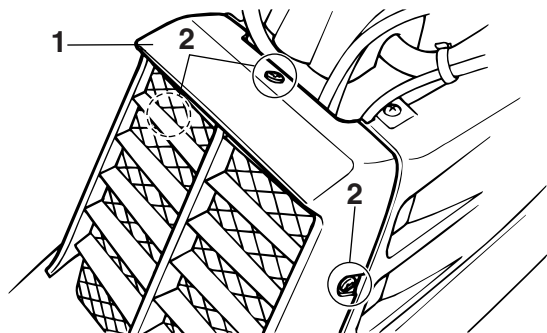

1. Radiator cover
2. Radiator cover bolt

3. Place a container under the engine and remove the coolant drain bolts.

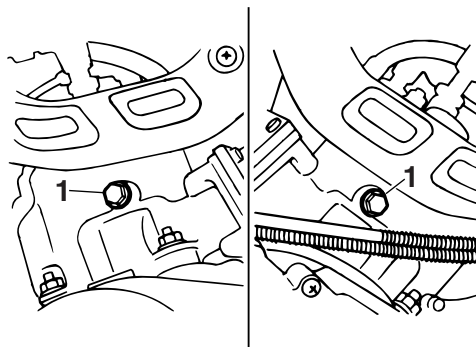

1. Coolant drain bolt

4. Remove the radiator cap.

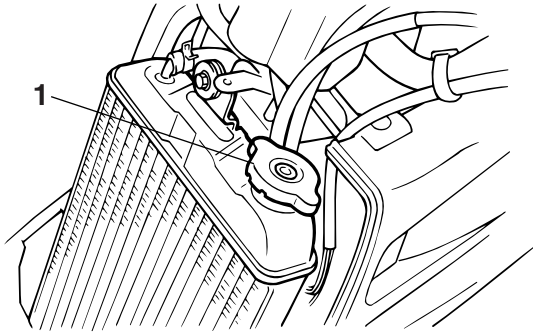

1. Radiator cap

5. Remove the coolant reservoir cap.

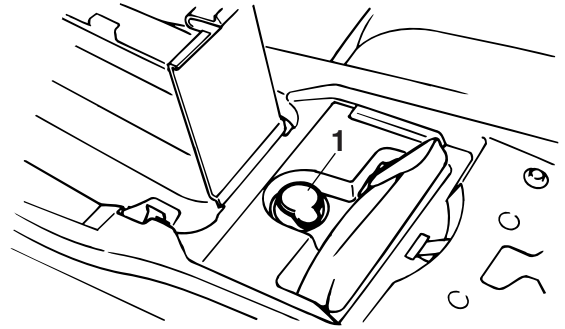

1. Coolant reservoir cap

6. Disconnect the hose on the coolant reservoir side and drain the coolant from the coolant reservoir.

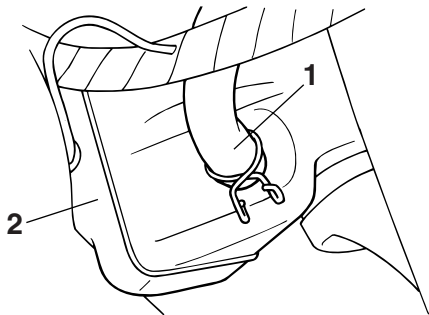

1. Coolant reservoir hose
2. Coolant reservoir

7. After draining the coolant, thoroughly flush the cooling system with clean tap water.
8. Replace the coolant drain bolt washers if they are damaged, and then tighten the coolant drain bolts to the specified torque.

Tightening torque:

Coolant drain bolt:

10 Nm (1.0 m·kgf, 7 ft·lbf)

9. Connect the coolant reservoir hose.
10. Pour the recommended coolant into the reser-

voir to the maximum level mark, and then install the reservoir cap.

11. Pour the recommended coolant into the radiator until it is full.

Antifreeze/water mixture ratio:

1:1

Recommended antifreeze:

High-quality ethylene glycol antifreeze containing corrosion inhibitors for aluminum engines

Coolant quantity:

Radiator capacity (including all routes):

1.50 L (1.59 US qt) (1.32 Imp.qt)

Coolant reservoir capacity (up to the maximum level mark):

0.28 L (0.30 US qt) (0.25 Imp.qt)

ECB00401

CAUTION:

- If coolant is not available, use distilled water or soft tap water instead. Do not use hard water or salt water since it is harmful to the engine.
- If water has been used instead of coolant, replace it with coolant as soon as possible, otherwise the cooling system will not be pro-

ected against frost and corrosion.

- If water has been added to the coolant, have a Yamaha dealer check the antifreeze content of the coolant as soon as possible, otherwise the effectiveness of the coolant will be reduced.

12. Install the radiator cap, start the engine, let it idle for several minutes, and then turn it off.
13. Remove the radiator cap to check the coolant level in the radiator. If it is low, add sufficient coolant until it reaches the top of the radiator, and then install the radiator cap.
14. Start the engine, and then check for coolant leakage.

8

NOTE:

If any leakage is found, have a Yamaha dealer check the cooling system.

15. Install the radiator cover by installing the bolts.

EBU23620

Cleaning the air filter element

The air filter element should be cleaned at the intervals specified in the periodic maintenance and lubrication chart. Clean the air filter element more frequently if you are riding in unusually wet or dusty

areas.

NOTE:

There is a check hose at the bottom of the air filter case. If dust or water collects in this hose, empty the hose and clean the air filter element and air filter case.

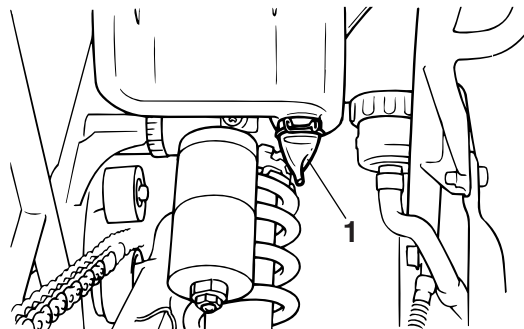

1. Air filter case check hose

1. Remove the seat. (See page 4-11.)
2. Remove the air filter case cover by unhooking the holders.

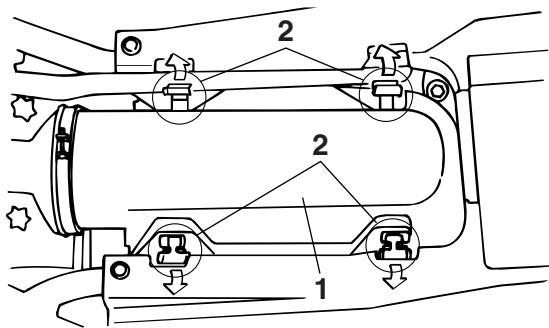

1. Air filter case cover
2. Air filter case cover holder
3. Pull the air filter element out of the air filter case.



1. Air filter element lock plate
4. Remove the lock plate by turning it, and then remove the sponge material from the air filter element frame.

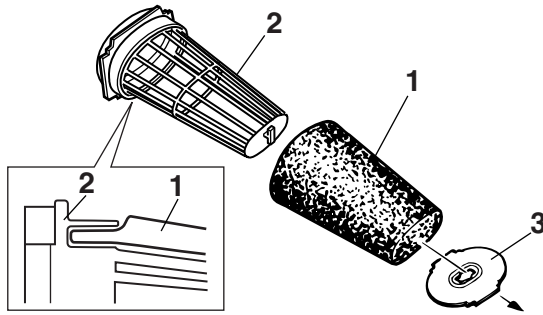

1. Sponge material
2. Air filter element frame
3. Air filter element lock plate

8

5. Wash the sponge material gently but thoroughly in solvent.

EWB01940

WARNING

Always use parts cleaning solvent to clean the sponge material. Never use low-flash-point solvents or gasoline to clean the sponge material because the engine could catch fire or explode.

6. Squeeze the excess solvent out of the sponge material and let it dry.

CAUTION:

Do not twist the sponge material when squeezing it.

7. Check the sponge material and replace it if damaged.
8. Apply a quality foam air filter oil to the sponge material.

NOTE:

The sponge material should be wet but not dripping.

9. Pull the sponge material over the air filter element frame, and then install the lock plate by turning it.

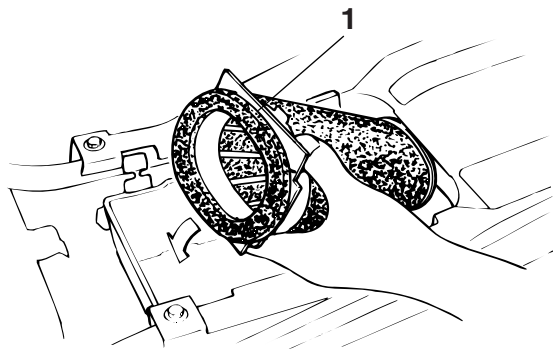

1. Air filter element

10. Insert the air filter element into the air filter case, and then install the air filter case cover by hooking the holders onto the air filter case.
11. Install the seat.

NOTE:

The air filter element should be cleaned every 20–40 hours. It should be cleaned and lubricated more often if the ATV is operated in extremely dusty areas. Each time the air filter element maintenance is performed, check the air inlet of the air filter case for obstructions. Check the air filter case rubber joint to the carburetor fittings and the rubber joint

manifold fittings for an air-tight seal. Tighten all fittings securely to avoid the possibility of unfiltered air entering the engine.

ECB00460

CAUTION:

- Make sure that the air filter element is properly seated in the air filter case.
- Never operate the engine with the air filter element removed. This will allow unfiltered air to enter the engine, causing rapid engine wear and possible engine damage. Additionally, operation without the air filter element will affect carburetor jetting with subsequent poor performance and possible engine overheating.

EBU28310

Cleaning the spark arrester

Be sure the exhaust pipe and muffler are cool before cleaning the spark arrester.

1. Remove the screws.

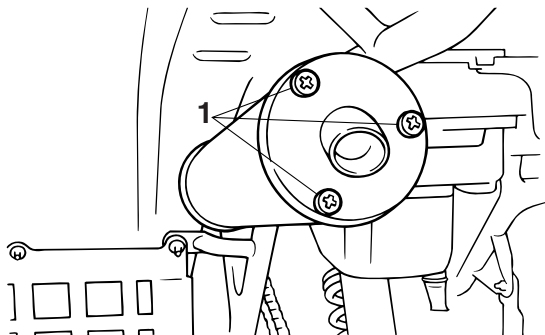

1. Screw

2. Remove the tailpipe by pulling it out of the muffler.
3. Tap the tailpipe lightly, and then use a wire brush to remove any carbon deposits from the spark arrester portion of the tailpipe and inside of the tailpipe housing.

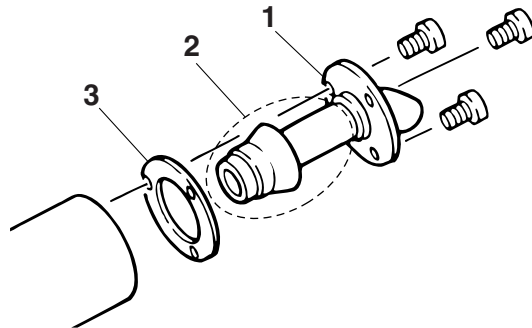

1. Tailpipe
2. Spark arrester
3. Gasket

4. Make sure the gasket is properly positioned, then insert the tailpipe into the muffler and align the screw holes.
5. Install the screws and tighten them.

EWB02340

⚠ WARNING

Do not start the engine when cleaning the spark arrester, otherwise it could cause injury to the eyes, burns, carbon monoxide poisoning, possibly leading to death, and start a fire. Always let the exhaust system cool prior to

touching exhaust components.

EBU23992

Changing the carburetor settings

In extremely cold weather, it is necessary to change the carburetor settings to maintain optimum engine performance and to prevent engine damage.

EWB01990

WARNING

- Improperly servicing or adjusting the carburetors could cause them to malfunction with the possibility of an accident, or the carburetors could leak fuel, which would be a fire hazard.
- Carburetor adjustments should only be performed by a Yamaha dealer. Do not attempt to perform these procedures unless you have mechanical knowledge and the necessary tools.
- Do not perform this procedure while the engine is hot. Place a rag under each carburetor to catch any fuel. Wipe up any spilled fuel completely.
- After servicing the carburetors, always check the throttle lever operation before op-

erating the ATV to make sure it is working correctly.

Standard settings	
Main jet	#200
Jet needle clip position	3rd groove
Pilot air screw	2.0 turns out

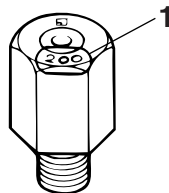

1. Main jet number

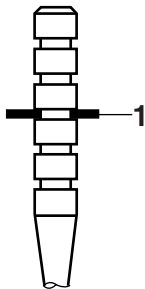

1. Standard position: Groove 3

Carburetor setting chart

Temperature	Altitude					
	0–1500 m (5000 ft)			Above 1500 m (5000 ft)		
	Main jet	Jet needle	Pilot air screw	Main jet	Jet needle	Pilot air screw
Above 0°C (32°F)	#200	3rd groove	2.0 turns out	#190	3rd groove	2 1/2 turns out
from +5 °C (41 °F) to –15 °C (5 °F)	#220	3rd groove	1 1/2 turns out	#200	3rd groove	2.0 turns out
from –10 °C (14 °F) to –30 °C (–22 °F)	#240	4th groove	1 1/2 turns out	#220	3rd groove	1 1/2 turns out

Changing the settings of the carburetors

To change the settings of the carburetors, you need to disassemble and remove them. Follow the procedures for both carburetors.

Disassembling and removing the carburetors

1. Turn the fuel cock to the "OFF" position.
2. Turn out the carburetor drain screw to drain the fuel.
3. Remove the seat.
4. Remove the radiator cover and side cover by removing the screws.

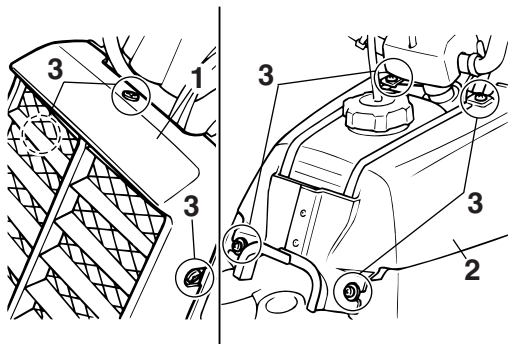

1. Radiator cover
2. Fuel tank
3. Screw

5. Disconnect the fuel hoses.
6. Remove the fuel tank by removing the bolts.

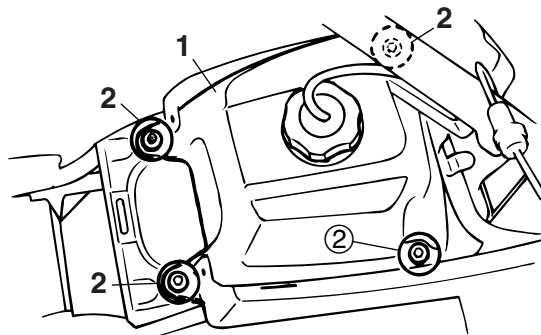

1. Fuel tank
2. Bolt

7. Remove the air filter case cover by unhooking the holders.

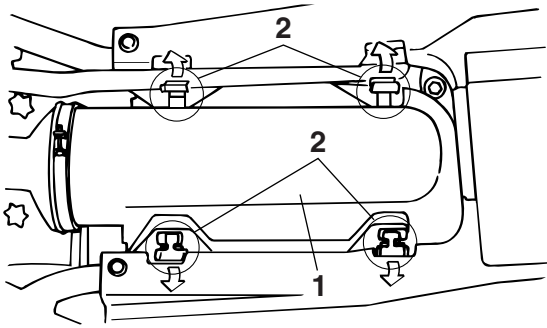

1. Air filter case cover
2. Air filter case cover holder

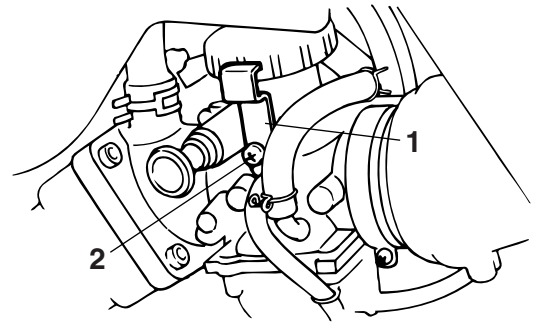

1. Mixing chamber cap securing plate
2. Screw

8

8. Remove the mixing chamber cap securing plate by removing the screw.

9. Loosen the carburetor joint screws.

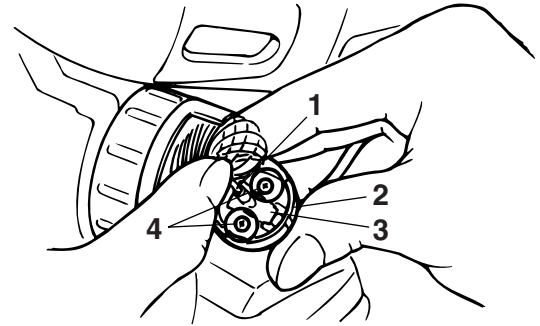
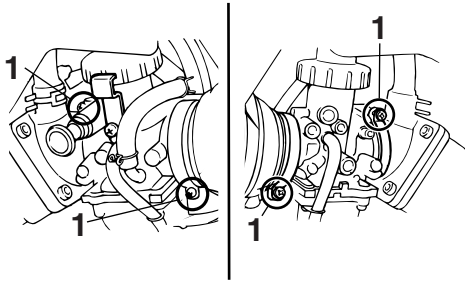

1. Joint screw

10. Remove the mixing chamber cap.
11. Remove the throttle cable from the throttle valve, and then remove the throttle cable holder by removing the screws.

1. Throttle cable
2. Throttle valve
3. Throttle cable holder
4. Screw

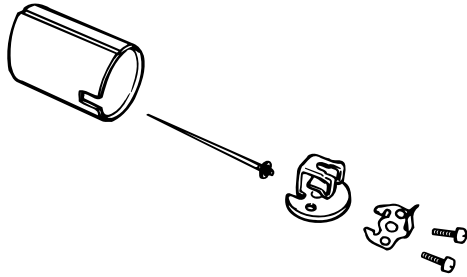

12. Remove the carburetor, and then remove the float chamber by removing the screws.

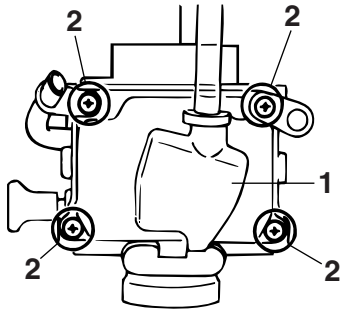

1. Float chamber
2. Screw

13. Remove the float and needle valve.

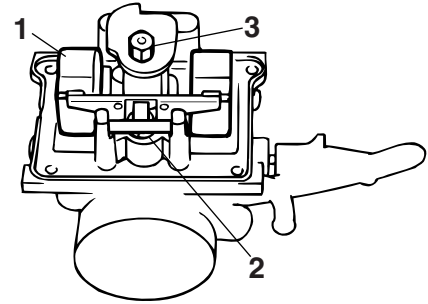

1. Float
2. Needle valve
3. Main jet

14. Change the main jet and the jet needle clip position.

- NOTE:** _____
- Optional main jets can be obtained at a Yamaha dealer.
 - After the jet needle clip position is changed, the throttle cables may need to be adjusted.
-

Assembling and installing the carburetors

Assemble and install both carburetors by the following steps.

1. Install the needle valve and float.
2. Install the float chamber by installing the screws.
3. Install the carburetor and tighten the joint screws.
4. Assemble the throttle valve.
5. Install the mixing chamber cap, and then tighten it securely to the specified torque.

Tightening torque:

Mixing chamber cap:

4 Nm (0.4 m·kgf, 2.9 ft·lbf)

6. Install the mixing chamber cap securing plate by installing the screw.

ECB00501

CAUTION:

Be sure to match one of the projections on the carburetor cap with one of the slots on the securing plate. If the securing plate does not match a projection, tighten the carburetor cap until they align. Do not loosen the carburetor cap.

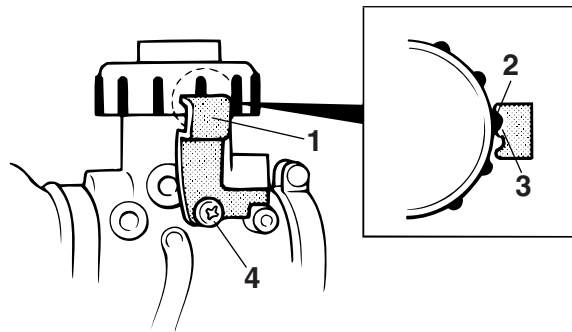

1. Mixing chamber cap securing plate
2. Projection
3. Slot
4. Screw

7. Tighten the mixing chamber cap securing plate screw to the specified torque.

Tightening torque:

Mixing chamber cap securing plate screw:
3.5 Nm (0.35 m·kgf, 2.5 ft·lbf)

8. Tighten the carburetor joint screws.

Adjusting the throttle cables

1. Move the throttle lever a few times.

2. Push the throttle lever forward until it stops and hold it in this position.
3. Check through each carburetor window to see if the punch mark on the throttle valve is at the specified position.

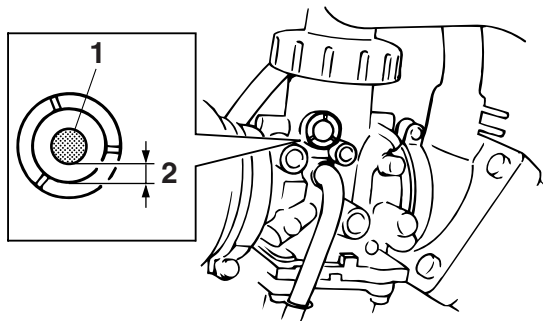

1. Punch mark
2. Specified position: 0–1mm

4. If not, loosen the locknut and turn the adjusting nut until the specified position is obtained.

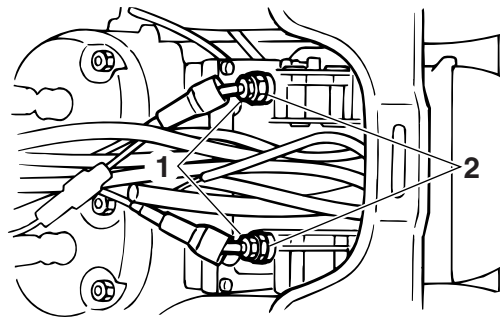

1. Adjusting nut
2. Locknut

5. Move the throttle lever a few times and re-check the position.
6. Install the fuel tank, side cover, radiator cover and air filter case cover.
7. Connect the fuel hoses.
8. Install the seat.

EBU24020

Adjusting the engine idling speed

The engine idling speed must be checked and, if necessary, adjusted as follows at the intervals specified in the periodic maintenance and lubrica-

tion chart.

NOTE: _____

- A diagnostic tachometer is needed to make this adjustment.
- The carburetor synchronization and the throttle cable free play must be checked, and adjusted if necessary, before adjusting the engine idling speed.

1. Start the engine and warm it up.

NOTE: _____

The engine is warm when it quickly responds to the throttle.

2. Attach the tachometer to the spark plug lead.
3. Turn in both pilot air screws until they lightly seat.
4. Turn out both pilot air screws to specification. (See the “Changing the carburetor settings” section on the page 8-21.)

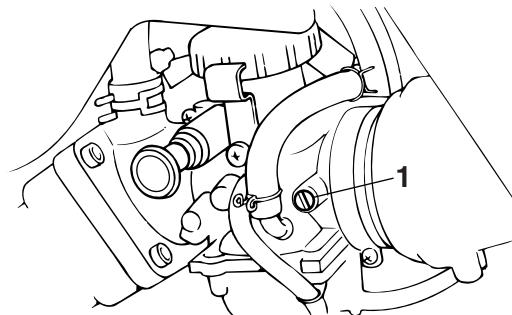

1. Pilot air screw

5. Remove the seat. (See page 4-11.)
6. Check the engine idling speed and, if necessary, adjust it to specification by turning the throttle stop screws at the carburetors. To increase the engine idling speed, turn the throttle stop screws in direction (a), and to decrease it, turn the screws in direction (b).

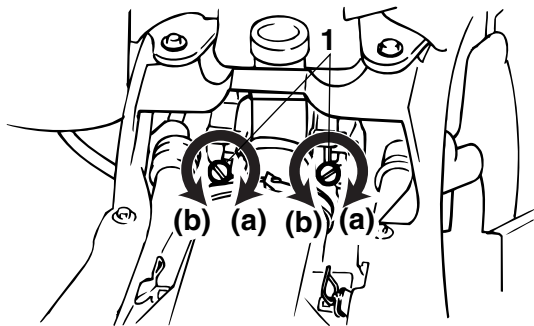

1. Throttle stop screw

Engine idling speed:
1450–1550 r/min

8

ECB00510

CAUTION:

- The throttle stop screws were preset at the factory. When adjusting the idling speed, turn both throttle stop screws the same amount, otherwise the carburetor synchronization will be incorrect.
- Adjusting the pilot air screws and the idling speed are separate procedures, but they must be adjusted at the same time to achieve

optimum engine performance.

NOTE:

If the specified idling speed cannot be obtained as described above, have a Yamaha dealer make the adjustment.

7. Install the seat.

EBU24043

Adjusting the throttle cable free play

The throttle cable free play should be checked and, if necessary, adjusted at the intervals specified in the periodic maintenance and lubrication chart.

The throttle cable free play should measure 4.0–6.0 mm (0.16–0.24 in) at the throttle lever. Periodically check the throttle cable free play and, if necessary, adjust it as follows.

NOTE:

The engine idling speed must be checked, and adjusted if necessary, before adjusting the throttle cable free play.

1. Loosen the locknut.
2. To increase the throttle cable free play, turn the adjusting bolt in direction (a). To decrease

the throttle cable free play, turn the adjusting bolt in direction (b).

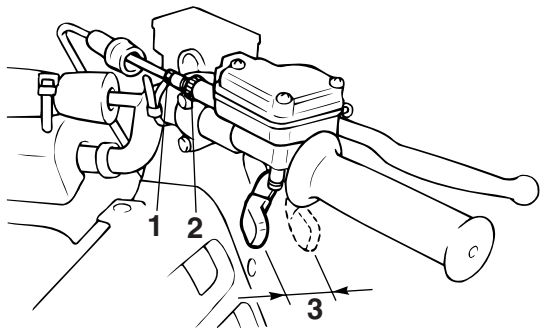

1. Throttle lever free play adjusting bolt
2. Locknut
3. Throttle cable free play

3. Tighten the locknut.

EBU24130

Checking the front and rear brake pads

The front and rear brake pads must be checked for wear at the intervals specified in the periodic maintenance and lubrication chart.

EBU24140

Front brake pads

Each brake pad is provided with a wear indicator, which allows you to check the brake pad wear without having to disassemble the brake. To check the brake pad wear, check the position of the wear indicator while applying the brake. If a brake pad has worn to the point that the wear indicator almost touches the brake disc, have a Yamaha dealer replace the brake pads as a set.

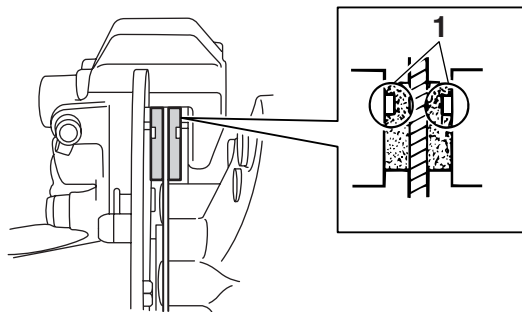

1. Wear indicator

EBU24190

Rear brake pads

Each brake pad is provided with a wear indicator, which allows you to check the brake pad wear

without having to disassemble the brake. To check the brake pad wear, check the position of the wear indicator while applying the brake. If a brake pad has worn to the point that the wear indicator almost touches the brake disc, have a Yamaha dealer replace the brake pads as a set.

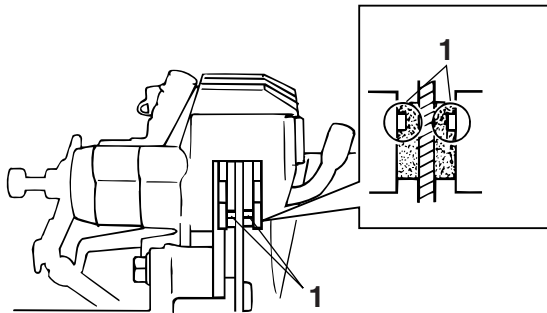

1. Wear indicator

EBU24251

Checking the brake fluid level

Insufficient brake fluid may allow air to enter the brake system, possibly causing it to become ineffective.

Before riding, check that the brake fluid is above the minimum level mark and replenish if neces-

sary. A low brake fluid level may indicate worn brake pads and/or brake system leakage. If the brake fluid level is low, be sure to check the brake pads for wear and the brake system for leakage.

Front brake

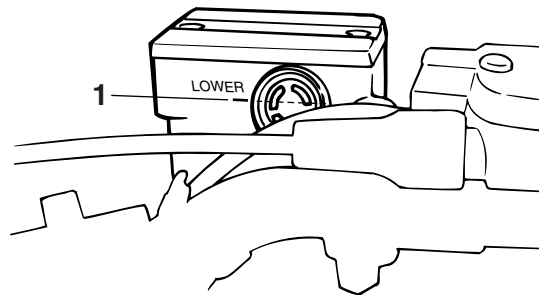

1. Minimum level mark

Rear brake

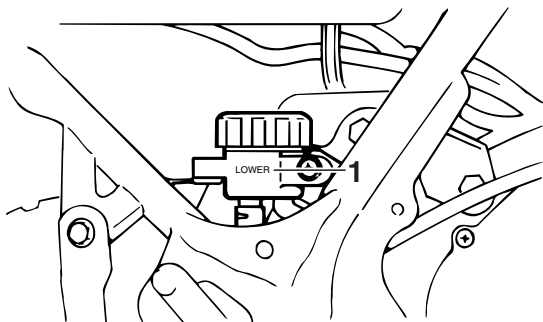

1. Minimum level mark

Observe these precautions:

- When checking the fluid level, make sure that the top of the brake fluid reservoir is level.
- Use only the recommended quality brake fluid, otherwise the rubber seals may deteriorate, causing leakage and poor braking performance.

Recommended brake fluid:
DOT 4

- Refill with the same type of brake fluid. Mixing fluids may result in a harmful chemical reaction and lead to poor braking performance.

- Be careful that water does not enter the brake fluid reservoir when refilling. Water will significantly lower the boiling point of the fluid and may result in vapor lock.
- Brake fluid may deteriorate painted surfaces or plastic parts. Always clean up spilled fluid immediately.
- As the brake pads wear, it is normal for the brake fluid level to gradually go down. However, if the brake fluid level goes down suddenly, have a Yamaha dealer check the cause.

EBU24290

Changing the brake fluid

Have a Yamaha dealer change the brake fluid at the intervals specified in the NOTE after the periodic maintenance and lubrication chart. In addition, have the oil seals of the master cylinders and calipers as well as the brake hoses replaced at the intervals listed below or whenever they are damaged or leaking.

- Oil seals: Replace every two years.
- Brake hoses: Replace every four years.

EBU24390

Checking the front brake lever free play

The brake lever free play must be checked at the

intervals specified in the periodic maintenance and lubrication chart. The brake lever should have a free play of zero mm (zero in) as shown. If the free play is incorrect, have a Yamaha dealer check the brake system.

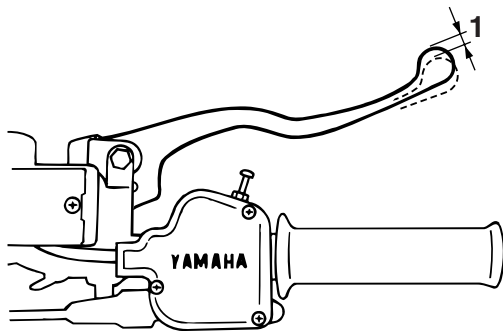

8

1. Brake lever free play

EWB02070

⚠ WARNING

Operating with improperly serviced or adjusted brakes could cause loss of braking ability, which could lead to an accident.

After servicing:

- **Make sure the brakes operate smoothly and that the free play is correct.**

- **Make sure the brakes do not drag.**
- **Make sure the brakes are not spongy. All air must be bled from the brake system.**

Replacement of brake components requires professional knowledge. These procedures should be performed by a Yamaha dealer.

EBU24611

Checking the brake pedal position

The brake pedal position must be checked and, if necessary, adjusted at the intervals specified in the periodic maintenance and lubrication chart.

The top of the brake pedal should be positioned 10.0 mm (0.39 in) below the top of the footrest as shown. If the brake pedal is not positioned as specified, have a Yamaha dealer adjust it.

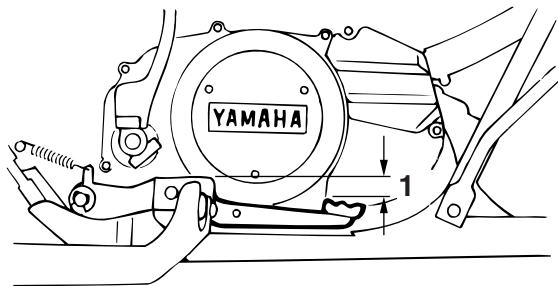

1. Brake pedal position

EWB02110

⚠ WARNING

Operating with improperly serviced or adjusted brakes could cause loss of braking ability, which could lead to an accident.

After servicing:

- Make sure the brakes operate smoothly and that the brake pedal position is correct.
- Make sure the brakes do not drag.
- Make sure the brakes are not spongy. All air must be bled from the brake system.

Replacement of brake components requires professional knowledge. These procedures

should be performed by a Yamaha dealer.

EBU24670

Adjusting the parking brake free play

The parking brake free play must be checked and, if necessary, adjusted at the intervals specified in the periodic maintenance and lubrication chart. Cable length "A" should measure 46–50 mm (1.81–1.97 in). Adjust the parking brake free play as follows.

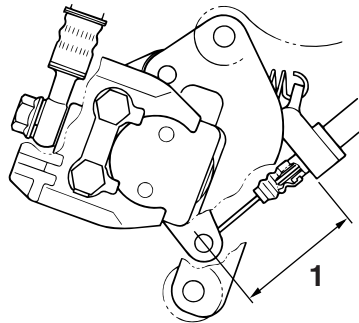

1. Cable length "A"

1. Release the parking brake.
2. Fully loosen the locknut and the adjusting bolt at the clutch lever.

3. Loosen the locknut and the adjusting bolt at the rear brake caliper.
4. Turn the adjusting bolt at the clutch lever in direction (a) to increase the cable length, and in direction (b) to decrease it.

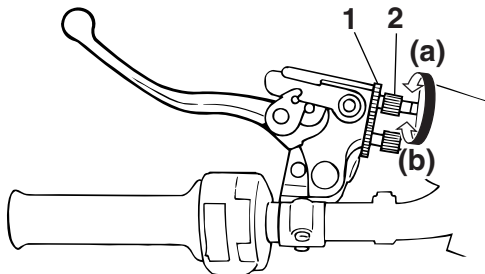

1. Locknut
2. Adjusting bolt

NOTE:

If the cable length cannot be adjusted to specification, consult a Yamaha dealer.

5. Tighten the locknut at the clutch lever.
6. Turn in the adjusting bolt at the rear brake caliper by hand until it feels tight, then turn it out

1/8 turn and tighten its locknut to the specified torque.

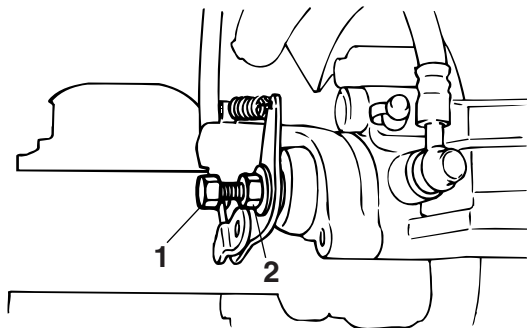

1. Locknut
2. Adjusting bolt

Tightening torque:

Locknut (rear brake caliper):
16 Nm (1.6 m·kgf, 11 ft·lbf)

ECB00520

CAUTION:

When tightening the locknut, hold the adjusting bolt with a wrench so that it does not turn together with the locknut.

⚠ WARNING

Operating with improperly serviced or adjusted brakes could cause the brakes to malfunction, resulting in reduced braking performance. This could increase the chance of a collision or accident. After adjusting the parking brake free play, block the rear of the ATV off the ground and spin the rear wheels. Check to make sure there is no brake drag. If brake drag is noticed, perform the adjustment again.

EBU24740

Brake light switches

The operation of the brake light switches must be checked and, if necessary, adjusted at the intervals specified in the periodic maintenance and lubrication chart.

The brake light switch for the brake pedal can be adjusted as follows, but the other brake light switches should be adjusted by a Yamaha dealer.

NOTE:

The brake light switch is properly adjusted when the brake light comes on just before braking takes

effect.

Turn the adjusting nut while holding the brake light switch in place. To make the brake light come on earlier, turn the adjusting nut in direction (a). To make the brake light come on later, turn the adjusting nut in direction (b).

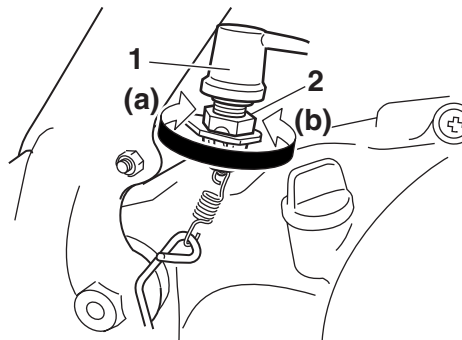

1. Brake light switch
2. Brake light switch adjusting nut

EBU24810

Adjusting the clutch lever free play

The clutch lever free play must be checked and, if necessary, adjusted at the intervals specified in the periodic maintenance and lubrication chart.

The clutch lever free play should measure as

shown. If the free play is incorrect, adjust it as follows.

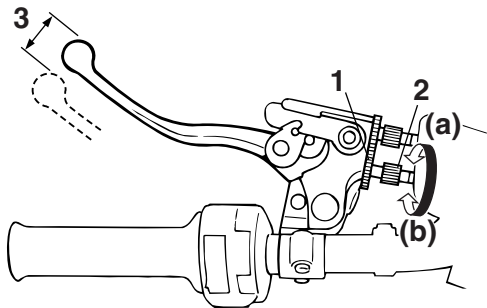

1. Locknut
2. Clutch lever free play adjusting bolt
3. Clutch lever free play

1. Loosen the locknut at the clutch lever.
2. To increase the clutch lever free play, turn the adjusting bolt in direction (a), and to decrease it, turn the bolt in direction (b).
3. Tighten the locknut.

NOTE:

If the specified free play cannot be obtained as described above or if the clutch does not operate cor-

rectly, have a Yamaha dealer check the internal clutch mechanism.

EBU24851

Drive chain slack

The drive chain slack should be checked before each ride and adjusted if necessary.

To check the drive chain slack

1. Place the ATV on a level surface.

NOTE:

When checking and adjusting the drive chain slack, there should be no weight on the ATV and all tires must be touching the ground.

2. Move the ATV back and forth to locate the tightest portion of the drive chain, and then measure the drive chain slack as shown.

Drive chain slack: 12.0–18.0 mm (0.47–0.71 in)

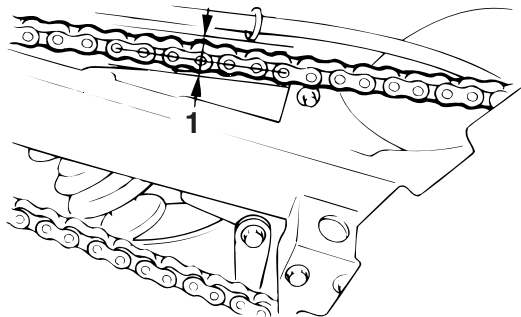

1. Drive chain slack

3. If the drive chain slack is incorrect, adjust it as follows.

To adjust the drive chain slack

1. Loosen the axle holding nuts.

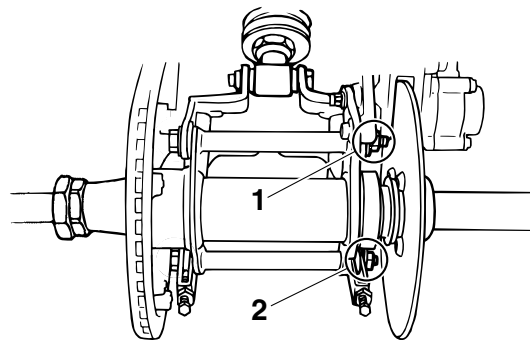

1. Axle holding nut (upper)

2. Axle holding nut (lower)

2. Loosen the locknut on each side of the swingarm. To tighten the drive chain, turn the adjusting bolts in direction (a). To loosen the drive chain, turn the adjusting bolts in direction (b) and push the wheels forward. Turn each adjusting bolt exactly the same amount to maintain correct axle alignment.

NOTE: _____

There are alignment marks on each side of the swingarm and on the wheel hubs. Use them to check for proper wheel axle alignment.

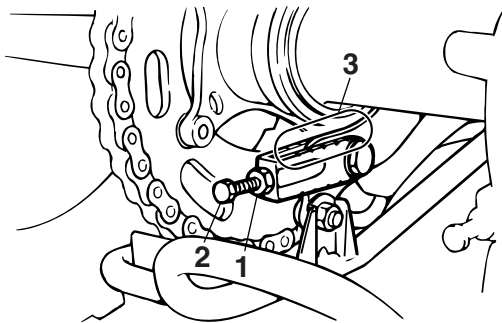

1. Locknut
2. Drive chain slack adjusting bolt
3. Alignment marks

8

ECB00541

CAUTION:

Improper drive chain slack will overload the engine as well as other vital parts of the ATV and can lead to drive chain slippage or breakage. To prevent this from occurring, keep the drive chain slack within the specified limits.

3. Tighten the locknuts and the axle holding nuts to the specified torques.

Tightening torques:

Locknut:

16 Nm (1.6 m-kgf, 11 ft·lbf)

Axle holding nut (upper):

120 Nm (12.0 m-kgf, 85 ft·lbf)

Axle holding nut (lower):

60 Nm (6.0 m-kgf, 43 ft·lbf)

EBU24880

Lubricating the drive chain

The drive chain must be cleaned and lubricated at the intervals specified in the periodic maintenance and lubrication chart, otherwise it will quickly wear out, especially when riding in dusty or wet areas. Service the drive chain as follows.

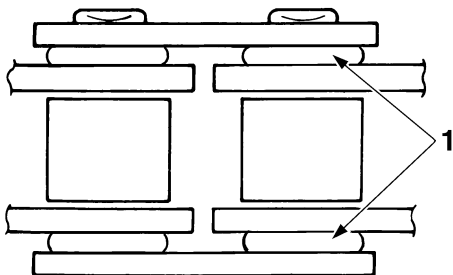

1. O-ring

ECB00560

CAUTION:

The drive chain must be lubricated after washing the ATV or riding in the rain.

1. Clean the drive chain with kerosene and a small soft brush.

ECB00570

CAUTION:

To prevent damaging the O-rings, do not clean the drive chain with steam cleaners, high-pressure washers or inappropriate solvents.

2. Wipe the drive chain dry.
3. Thoroughly lubricate the drive chain with a special O-ring chain lubricant.

ECB00580

CAUTION:

Do not use engine oil or any other lubricants for the drive chain, as they may contain substances that could damage the O-rings.

EBU24900

Checking and lubricating the cables

The operation and the condition of all control cables should be checked before each ride, and the cables and cable ends should be lubricated if necessary. If a cable is damaged or does not move smoothly, have a Yamaha dealer check or replace it.

Recommended lubricant:
Engine oil

8

EWB02130

! WARNING

Inspect cables frequently and replace if damaged. Corrosion can result when the cable sheaths become damaged, and cables can also become frayed or kinked, which could restrict the operation of controls and lead to an accident or injury.

EBU24920

Checking and lubricating the brake and clutch levers

The operation of the brake and clutch levers should be checked before each ride, and the lever pivots should be lubricated if necessary.

Recommended lubricant:

Lithium-soap-based grease (all-purpose grease)

EBU24930

Checking and lubricating the brake and shift pedals

The operation of the brake and shift pedals should be checked before each ride, and the pedal pivots should be lubricated if necessary.

Recommended lubricant:

Lithium-soap-based grease (all-purpose grease)

EBU24961

Checking the wheel bearings

The front and rear wheel bearings must be checked at the intervals specified in the periodic maintenance and lubrication chart. If there is play

in a wheel hub or if a wheel does not turn smoothly, have a Yamaha dealer check the wheel bearings.

EBU25001

Lubricating the rear suspension relay arm and connecting arm pivoting points

The rear suspension relay arm and connecting arm pivoting points must be lubricated at the intervals specified in the periodic maintenance and lubrication chart.

Lubricate the pivoting points using a grease gun.

Recommended lubricant:

Lithium-soap-based grease

Lubricating the upper and lower arm pivots

The upper and lower arm pivots must be lubricated at the intervals specified in the periodic maintenance and lubrication chart.

Lubricate the pivoting points using a grease gun.

Recommended lubricant:
Lithium-soap-based grease

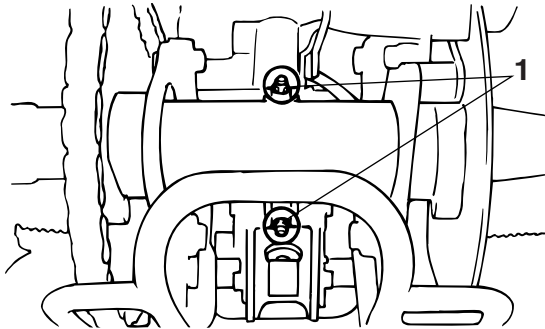

1. Grease nipple

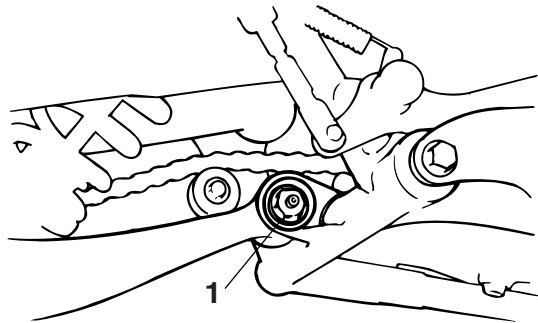

1. Grease nipple

Left side

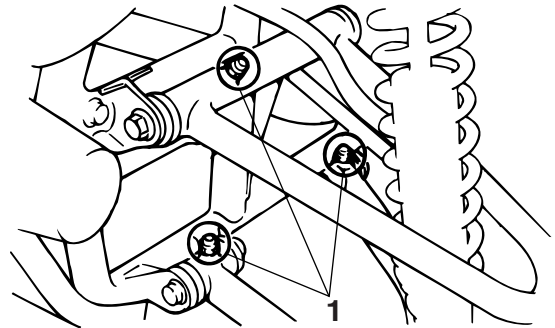

1. Grease nipple

Right side

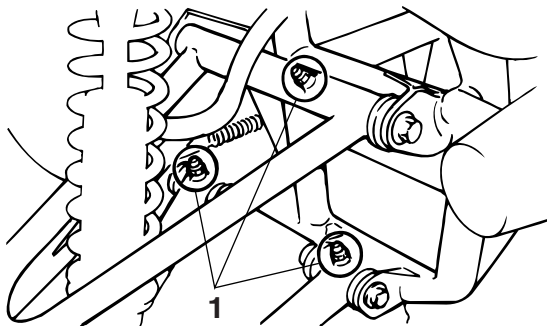

1. Grease nipple

EBU26881

8 Replacing a headlight bulb

If a headlight bulb burns out, replace it as follows.

1. Remove the headlight unit by removing the screw.

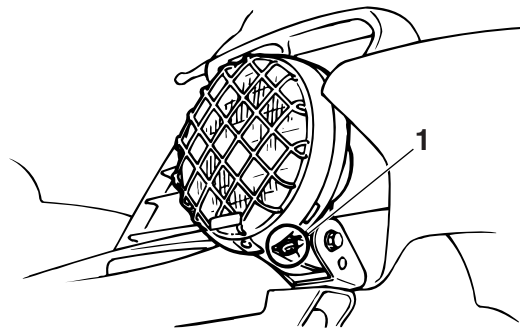

1. Screw
2. Remove the headlight bulb holder cover.

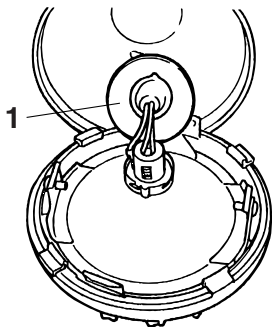

1. Headlight bulb holder cover

3. Remove the bulb holder by turning it counter-clockwise.

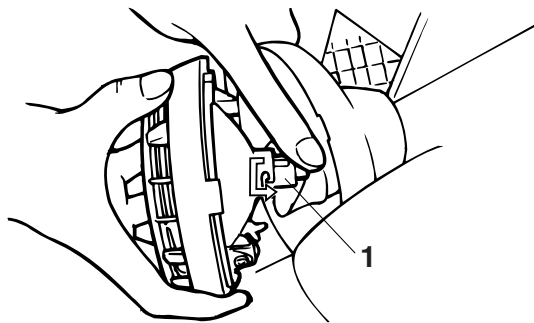

1. Headlight bulb holder

4. Remove the defective bulb.

EWB02200

⚠ WARNING

A headlight bulb is hot when it is on and immediately after it is turned off. Wait for the bulb to cool before touching or removing it. You can be burned, or a fire could start if the bulb touches something flammable.

5. Place a new bulb into position, and then install the bulb holder by turning it clockwise.

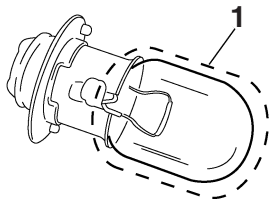

1. Do not touch the glass part of the bulb.

ECB00650

CAUTION: _____

Do not touch the glass part of the headlight bulb to keep it free from oil, otherwise the transparency of the glass, the luminosity of the bulb, and the bulb life will be adversely affected. Thoroughly clean off any dirt and fingerprints on the headlight bulb using a cloth moistened with alcohol or thinner.

6. Install the bulb holder cover.

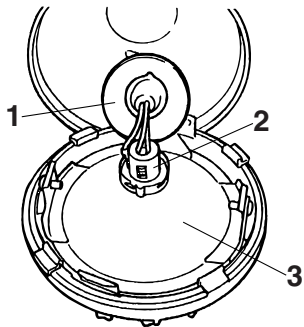

1. Headlight bulb holder cover
2. Headlight bulb holder
3. Headlight unit

ECB00680

CAUTION: _____

Make sure the bulb holder cover is securely fitted over the bulb holder and seated against the reflector.

7. Place the headlight unit in the original position, and then install the screw.
8. Adjust the headlight beam if necessary.

Adjusting a headlight beam

CAUTION:

It is advisable to have a Yamaha dealer make this adjustment.

To raise a headlight beam, turn the adjusting screw in direction (a).

To lower a headlight beam, turn the adjusting screw in direction (b).

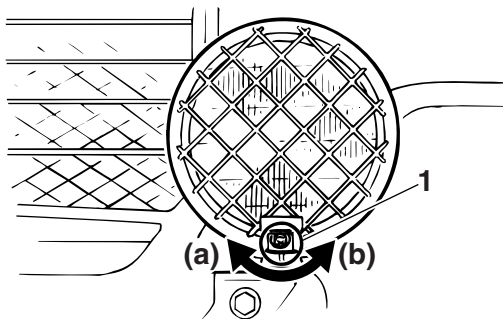

1. Headlight beam adjusting screw

Replacing the tail/brake light bulb

If the tail/brake light bulb burns out, replace it as

follows.

1. Remove the bulb holder (together with the bulb) by turning it counterclockwise.

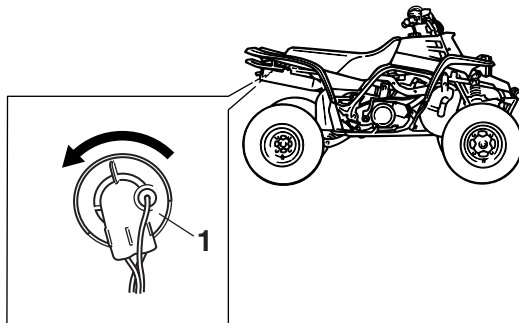

1. Tail/brake light bulb holder

2. Remove the defective bulb by pushing it in and turning it counterclockwise.

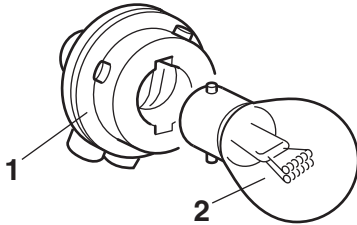

1. Tail/brake light bulb holder
2. Tail/brake light bulb

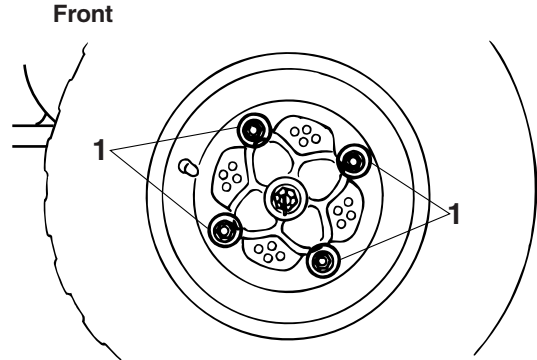

1. Wheel nut

8

3. Insert a new bulb into the bulb holder, push it in, and then turn it clockwise until it stops.
4. Install the bulb holder (together with the bulb) by turning it clockwise.

EBU25650

Removing a wheel

1. Loosen the wheel nuts.

Rear

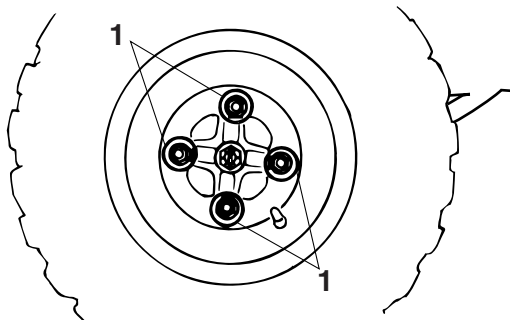

1. Wheel nut
2. Elevate the ATV and place a suitable stand under the frame.
3. Remove the nuts from the wheel.
4. Remove the wheel.

EBU25660

Installing a wheel

1. Install the wheel and the nuts.
2. Lower the ATV to the ground.
3. Tighten the wheel nuts to the specified torques.

Tightening torques:

Front wheel nut:

45 Nm (4.5 m·kgf, 32 ft·lbf)

Rear wheel nut:

45 Nm (4.5 m·kgf, 32 ft·lbf)

EBU25740

Troubleshooting

Although Yamaha ATVs receive a thorough inspection before shipment from the factory, trouble may occur during operation. Any problem in the fuel, compression, or ignition systems, for example, can cause poor starting and loss of power.

The following troubleshooting charts represent quick and easy procedures for checking these vital systems yourself. However, should your ATV require any repair, take it to a Yamaha dealer, whose skilled technicians have the necessary tools, experience, and know-how to service the ATV properly. Use only genuine Yamaha replacement parts. Imitation parts may look like Yamaha parts, but they are often inferior, have a shorter service life and can lead to expensive repair bills.

 **WARNING**

Do not smoke when checking the fuel system. Fuel can ignite or explode, causing severe injury or property damage. Make sure there are no open flames or sparks in the area, including pilot lights from water heaters or furnaces.

Troubleshooting charts

Starting problems or poor engine performance

1. Fuel

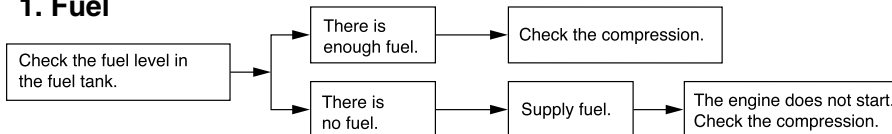

2. Compression

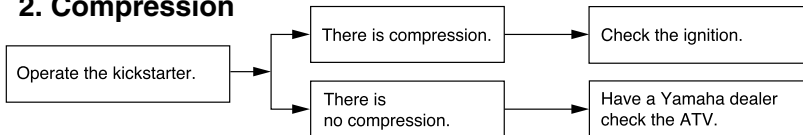

3. Ignition

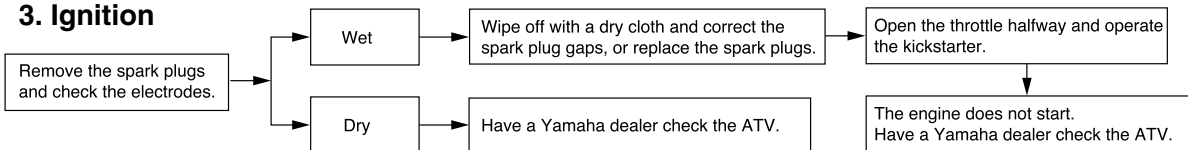

Engine overheating

EWB02290



WARNING

Wait for the engine and radiator to cool before removing the radiator cap. You could be burned by hot fluid and steam blown out under pressure. Always put a thick rag over the cap when opening. Allow any remaining pressure to escape before completely removing the cap.

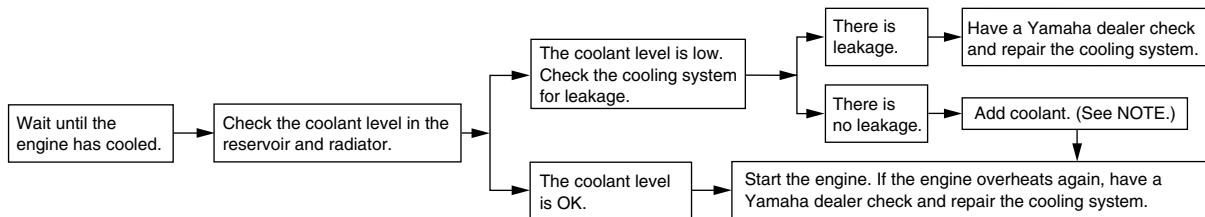

8

NOTE:

If coolant is not available, tap water can be temporarily used instead, provided that it is changed to the recommended coolant as soon as possible.

CLEANING AND STORAGE

EBU25920

Cleaning

Frequent, thorough cleaning of your ATV will not only enhance its appearance but will improve its general performance and extend the useful life of many components.

1. Before cleaning the ATV:
 - a. Block off the end of the exhaust pipe to prevent water entry. A plastic bag and strong rubber band may be used.
 - b. Make sure the spark plugs and all filler caps are properly installed.
2. If the engine case is excessively greasy, apply degreaser with a paint brush. Do not apply degreaser to the chain, sprockets or wheel axles.
3. Rinse the dirt and degreaser off with a garden hose. Use only enough pressure to do the job.

ECB00710

CAUTION:

Excessive water pressure may cause water seepage and deterioration of wheel bearings, brakes, transmission seals and electrical devices. Many expensive repair bills have result-

ed from improper high-pressure detergent applications such as those available in coin-operated car washers.

4. Once most of the dirt has been hosed off, wash all surfaces with warm water and mild, detergent-type soap. An old toothbrush or bottle brush is handy for hard-to-reach places.
5. Rinse the ATV off immediately with clean water and dry all surfaces with a chamois, clean towel or soft absorbing cloth.
6. Dry the chain and lubricate it to prevent it from rusting.
7. Clean the seat with a vinyl upholstery cleaner to keep the cover pliable and glossy.
8. Automotive type wax may be applied to all painted and chrome plated surfaces. Avoid combination cleaner-waxes. Many contain abrasives which may mar the paint or protective finish. When finished cleaning, start the engine and let it idle for several minutes.

EWB02310



WARNING

Wet brakes may have reduced stopping ability,

increasing the chance of an accident. Test the brakes after washing. Apply the brakes several times at slow speeds to let friction dry out the linings.

EBU25951

Storage

Short-term

Always store your ATV in a cool, dry place and, if necessary, protect it against dust with a porous cover.

ECB00720

CAUTION:

- **Storing the ATV in a poorly ventilated room or covering it with a tarp while it is still wet, will allow water and humidity to seep in and cause rust.**
 - **To prevent corrosion, avoid damp cellars, stables (because of the presence of ammonia) and areas where strong chemicals are stored.**
-

Long-term

Before storing your ATV for several months:

1. Follow all the instructions in the “Cleaning”

section of this chapter.

2. Turn the fuel cock lever to “OFF”.
3. Drain the carburetor float chamber by loosening the drain bolt; this will prevent fuel deposits from building up. Pour the drained fuel into the fuel tank.
4. Fill up the fuel tank and add fuel stabilizer (if available) to prevent the fuel from deteriorating.

Specified amount:

7.5 ml of stabilizer to each liter of fuel (or 1 oz of stabilizer to each gallon of fuel)

5. Perform the following steps to protect the cylinders, piston rings, etc. from corrosion.
 - a. Remove the spark plug caps and spark plugs.
 - b. Pour a teaspoonful of engine oil into each spark plug bore.
 - c. Install the spark plug caps onto the spark plugs, and then place the spark plugs on the cylinder head so that the electrodes are grounded. (This will limit sparking during the next step.)
 - d. Turn the engine over several times with the starter. (This will coat the cylinder walls

with oil.)

- e. Remove the spark plug caps from the spark plugs, and then install the spark plugs and the spark plug caps.
6. Lubricate all control cables and the pivoting points of all levers and pedals.
7. Check and, if necessary, correct the tire air pressure, and then block up the ATV so that all of its wheels are off the ground. Alternatively, turn the wheels a little every month in order to prevent the tires from becoming degraded in one spot.
8. Cover the muffler outlet with a plastic bag to prevent moisture from entering it.

NOTE: _____

Make any necessary repairs before storing the ATV.

SPECIFICATIONS

EBU25977

Dimensions:

- Overall length:
1855 mm (73.0 in)
- Overall width:
1100 mm (43.3 in)
- Overall height:
1080 mm (42.5 in)
- Seat height:
800 mm (31.5 in)
- Wheelbase:
1280 mm (50.4 in)
- Ground clearance:
135 mm (5.3 in)
- Minimum turning radius:
3600 mm (142 in)

Weight:

- With oil and fuel:
187.0 kg (412 lb)

Engine:

- Engine type:
Liquid cooled 2-stroke
- Cylinder arrangement:
Forward-inclined parallel 2-cylinder
- Displacement:
347.0 cm³
- Bore × stroke:
64.0 × 54.0 mm (2.52 × 2.13 in)

Compression ratio:

6.50 :1

Starting system:

Kickstarter

Lubrication system:

Premix

Type:

YAMALUBE 2-R, Castrol R30, A545, A747

Engine oil quantity:

Mixing ratio:

YAMALUBE R 24:1

Transmission oil:

Type:

SAE10W30 type SE motor oil (EUR)

YAMALUBE 4 (10W30) or SAE10W30 type SE motor oil (AUS)(NZL)

Quantity:

1.5 L (1.59 US qt) (1.32 Imp.qt)

Cooling system:

Coolant reservoir capacity (up to the maximum level mark):

0.28 L (0.30 US qt) (0.25 Imp.qt)

Radiator capacity (including all routes):

1.50 L (1.59 US qt) (1.32 Imp.qt)

Air filter:

Air filter element:

Wet element

Fuel:

Recommended fuel:

Premium unleaded gasoline only

Fuel tank capacity:

12.0 L (3.17 US gal) (2.64 Imp.gal)

Fuel reserve amount:

2.5 L (0.66 US gal) (0.55 Imp.gal)

Carburetor:

Manufacturer:

MIKUNI

Type x quantity:

VM26SS x 2

Spark plug (s):

Manufacturer/model:

NGK/BR8ES

Spark plug gap:

0.7–0.8 mm (0.028–0.031 in)

Clutch:

Clutch type:

Wet, multiple-disc

Transmission:

Primary reduction system:

Helical gear

Primary reduction ratio:

66/23 (2.869)

Secondary reduction system:

Chain drive

Secondary reduction ratio:

41/14 (2.929)

Transmission type:

Constant mesh 6-speed

Operation:

Left foot operation

1st:

32/13 (2.461)

2nd:

29/16 (1.812)

3rd:

27/18 (1.500)

4th:

25/20 (1.250)

5th:

23/22 (1.045)

6th:

21/24 (0.875)

Chassis:

Frame type:

Steel tube frame

Caster angle:

9.0 °

Trail:

40.0 mm (1.57 in)

Front tire:

Type:

Tubeless

Size:

AT21 x 7-10

Manufacturer/model:

DUNLOP/KT851B

Rear tire:

Type:

Tubeless

Size:

AT20 x 10-9

Manufacturer/model:

DUNLOP/KT877A

Loading:

Maximum loading limit:

100.0 kg (220 lb)

(Total weight of rider, cargo, accessories, and tongue)

Tire air pressure (measured on cold tires):

Recommended:

Front:

30.0 kPa (4.4 psi) (0.300 kgf/cm²)

Rear:

30.0 kPa (4.4 psi) (0.300 kgf/cm²)

Minimum:

Front:

27.0 kPa (3.9 psi) (0.270 kgf/cm²)

Rear:

27.0 kPa (3.9 psi) (0.270 kgf/cm²)

Maximum:

Front:

33.0 kPa (4.8 psi) (0.330 kgf/cm²)

Rear:

33.0 kPa (4.8 psi) (0.330 kgf/cm²)

Front wheel:

Wheel type:

Panel wheel

Rim size:

10 x 6.0AT

Rear wheel:

Wheel type:

Panel wheel

Rim size:

9 x 8.5AT

Front brake:

Type:

Dual disc brake

Operation:

Right hand operation

Recommended fluid:

DOT 4

Rear brake:

Type:

Single disc brake

Operation:

Right foot operation

Recommended fluid:

DOT 4

Front suspension:

Type:

Double wishbone

Spring/shock absorber type:

Coil spring/oil damper

Wheel travel:

230 mm (9.1 in)

Rear suspension:

Type:

Swingarm (link suspension)

Spring/shock absorber type:

Coil spring/gas-oil damper

Wheel travel:
220 mm (8.7 in)

Electrical system:

Ignition system:
CDI

Charging system:
AC magneto

Headlight:

Bulb type:
Krypton bulb

Bulb voltage, wattage x quantity:

Headlight:
12 V, 30.0/30.0 W × 2

Tail/brake light:
12 V, 5.0/21.0 W × 1

CONSUMER INFORMATION

EBU26011

Identification numbers

Record the key identification number, vehicle identification number and model label information in the spaces provided below for assistance when ordering spare parts from a Yamaha dealer or for reference in case the ATV is stolen.

● KEY IDENTIFICATION NUMBER:

● VEHICLE IDENTIFICATION NUMBER:

● MODEL LABEL INFORMATION:

EBU26020

Key identification number

The key identification number is stamped into the key. Record this number in the space provided and use it for reference when ordering a new key.

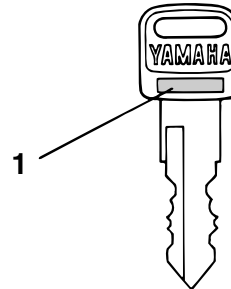

1. Key identification number

EBU26030

Vehicle identification number

The vehicle identification number is stamped into the frame.

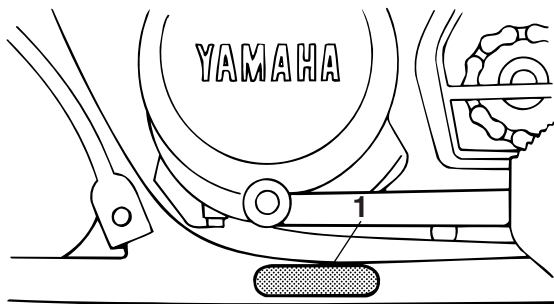

1. Vehicle identification number

NOTE: _____
The vehicle identification number is used to identify your ATV.

EBU26050

Model label

The model label is affixed at the location in the illustration. Record the information on this label in the space provided. This information will be needed when ordering spare parts from a Yamaha dealer.

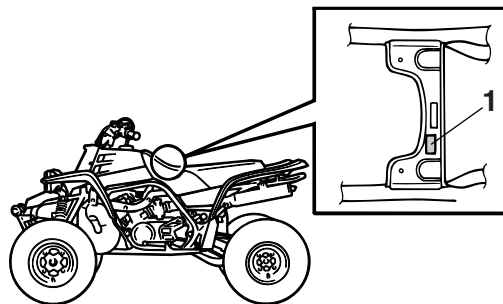

1. Model label

INDEX

A

- Accessories and loading 6-6
- Air filter element, cleaning 8-16

B

- Brake and clutch levers, checking and lubricating 8-42
- Brake and shift pedals, checking and lubricating 8-42
- Brake fluid, changing 8-33
- Brake fluid level, checking 8-32
- Brake lever 4-5
- Brake lever free play, checking the front 8-33
- Brake light switches 8-37
- Brake pads, checking the front and rear 8-31
- Brake pedal 4-5
- Brake pedal position, checking 8-34
- Brakes, front and rear 5-4

C

- Cables, checking and lubricating 8-41
- Carburetor settings, changing 8-21
- Chassis fasteners 5-8
- Cleaning 9-1
- Clutch lever 4-4
- Clutch lever free play, adjusting 8-37
- Coolant 5-4, 8-11

D

- Drive chain 5-5
- Drive chain, lubricating 8-40

- Drive chain slack 8-38

E

- Engine break-in 6-4
- Engine, cold start 6-1
- Engine idling speed 8-28
- Engine, starting a warm 6-2
- Engine stop switch 4-2

F

- Fuel 4-8
- Fuel and 2-stroke engine oil mixing ratio 5-4
- Fuel cock 4-9
- Fuel tank cap 4-7

H

- Handlebar switches 4-2
- Headlight beam, adjusting 8-47
- Headlight bulb, replacing 8-44

I

- Identification numbers 11-1
- Instruments, lights and switches 5-8

K

- Key identification number 11-1
- Kickstarter 4-7

L

- Label locations 2-1
- Light switch 4-2

M	
Main switch	4-1
Model label.....	11-2
O	
Owner's manual and tool kit.....	8-1
P	
Parking.....	6-5
Parking brake.....	4-5
Parking brake free play, adjusting.....	8-35
Parking on a slope	6-6
Part locations	3-1
Periodic maintenance and lubrication chart.....	8-3
Pre-operation check list	5-1
R	
Riding your ATV.....	7-1
S	
Safety information	1-1
Seat.....	4-11
Shifting	6-3
Shift pedal	4-7
Shock absorber assemblies, adjusting the front	4-12
Shock absorber assembly, adjusting the rear.....	4-13
Spark arrester, cleaning.....	8-19
Spark plugs, checking.....	8-7
Specifications.....	10-1
Speed limiter	4-3
Starter (choke)	4-10
Storage	9-2
Suspension, lubricating the upper and lower arm pivots	8-43

Suspension relay arm and connecting arm pivoting points, lubricating the rear	8-42
---	------

T	
Tail/brake light bulb, replacing	8-47
Throttle cable free play, adjusting.....	8-30
Throttle lever	4-2, 5-5
Throttle OverRide System.....	4-3
Tire pressure, measuring	5-7
Tires	5-6
Tire wear limit.....	5-7
Transmission oil	5-4, 8-9
Troubleshooting	8-49
Troubleshooting charts	8-51

V	
Vehicle identification number.....	11-1

W	
Wheel bearings, checking.....	8-42
Wheel, installing.....	8-49
Wheel, removing.....	8-48



YAMAHA MOTOR CO., LTD.

PRINTED ON RECYCLED PAPER

PRINTED IN JAPAN
2006.07-0.7x1 
(E)