



⚠ READ THIS MANUAL CAREFULLY!
It contains important safety information.

⚠ LIRE ATTENTIVEMENT CE MANUEL!
Il comprend d'importantes informations de sécurité.

⚠ ¡LEA ESTE MANUAL ATENTAMENTE!
Contiene indicaciones importantes acerca de la seguridad.

OWNER'S MANUAL
MANUEL DU PROPRIÉTAIRE
MANUAL DEL PROPIETARIO

AUTOMATIC

GRAND DUAL

125

YFM125GB

1PY-28199-60



PRINTED ON RECYCLED PAPER
IMPRIMÉ SUR PAPIER RECYCLÉ
IMPRESO EN PAPEL RECICLADO

PRINTED IN JAPAN
2011.03-0.2×1 CR
(E,F,S)



⚠ READ THIS MANUAL CAREFULLY!
It contains important safety information.

OWNER'S MANUAL

AUTOMATIC

ER174LY

125

YFM125GB

1PY-28199-60-E0



Read this manual carefully before operating this vehicle. This manual should stay with this vehicle if it is sold.

EC Declaration of Conformity

conforming to Directive 2006/42/EC

**We, YAMAHA MOTOR CO., LTD. 2500 Shingai, Iwata, Japan,
declare in sole responsibility, that the product**

YFM125A (YFM125G) (JY4AE02W0B0014406-)

(Make, model)

**to which this declaration applies, conforms to the essential health
and safety requirements of Directive 2006/42/EC**

(If applicable)

and to the other relevant Directives of EEC

2004/108/EC

(Title and/or number and date of issue of the other Directives of EEC)

(If applicable)

**To effect correct application of the essential health and safety requirements
stated in the Directives of EEC, the following-standards and/or technical
specifications were consulted:**

ANSI/SVIA 1-2010

(Title and/or number and date of issue of standards and/or specifications)

Authorized Representative

YAMAHA MOTOR EUROPE N.V.

Koolhovenlaan 101, 1119 NC Schiphol-Rijk, The Netherlands

Signature

Shinya Shimada

General Manager

RV Engineering Division

Recreational Vehicle Business Unit

Motorcycle Business Operations

YAMAHA MOTOR CO., LTD.

Date of Issue

19 January, 2011

INTRODUCTION

Congratulations on your purchase of the Yamaha YFM125GB. This ATV represents the result of many years of Yamaha experience in the production of fine sporting, touring, and pacesetting racing machines. With the purchase of this Yamaha, you can now appreciate the high degree of craftsmanship and reliability that have made Yamaha a leader in these fields.

This manual will provide you with a good basic understanding of the features and operation of this ATV. **This manual includes important safety information. It provides information about special techniques and skills necessary to ride the ATV.** It also includes basic maintenance and inspection procedures. If you have any questions regarding the operation or maintenance of your ATV, please consult a Yamaha dealer.



AN IMPORTANT SAFETY MESSAGE:

- Read this manual completely before operating your ATV. Make sure you understand all instructions.
- Pay close attention to the warning and notice labels on the ATV.
- This ATV should not be ridden by anyone under 16 years of age.

IMPORTANT MANUAL INFORMATION

FAILURE TO FOLLOW THE WARNINGS CONTAINED IN THIS MANUAL CAN RESULT IN SERIOUS INJURY OR DEATH.

Particularly important information is distinguished in this manual by the following notations:

	This is the safety alert symbol. It is used to alert you to potential personal injury hazards. Obey all safety messages that follow this symbol to avoid possible injury or death.
	A WARNING indicates a hazardous situation which, if not avoided, could result in death or serious injury.
	A NOTICE indicates special precautions that must be taken to avoid damage to the vehicle or other property.
TIP	A TIP provides key information to make procedures easier or clearer.

* Product and specifications are subject to change without notice.

EBU17350

IMPORTANT NOTICE

EBU17372

This ATV is designed and manufactured for use on unpaved surfaces only. It is unsafe to operate this ATV on any paved surface, paved street, paved road or motorway.

Please check your local riding laws and regulations before operating this ATV.

EBU17390

**YFM125GB
OWNER'S MANUAL
©2011 by Yamaha Motor Co., Ltd.
1st edition, February 2011
All rights reserved.
Any reprinting or unauthorized use
without the written permission of
Yamaha Motor Co., Ltd.
is expressly prohibited.
Printed in Japan.**

TABLE OF CONTENTS

LOCATION OF THE WARNING AND SPECIFICATION LABELS	1-1	Starter (choke)	4-10
SAFETY INFORMATION	2-1	Seat	4-10
DESCRIPTION	3-1	Front carrier	4-11
Left view	3-1	Rear carrier	4-11
Right view	3-1	PRE-OPERATION CHECKS	5-1
Controls and instruments	3-2	Fuel	5-3
INSTRUMENT AND CONTROL FUNCTIONS	4-1	Engine oil	5-3
Main switch	4-1	Transmission oil	5-3
Indicator lights	4-2	Front and rear brakes	5-3
Handlebar switches	4-2	Throttle lever	5-3
Throttle lever	4-3	Drive chain	5-3
Speed limiter	4-4	Tires	5-3
Front brake lever	4-4	Chassis fasteners	5-6
Rear brake lever	4-5	Instruments, lights and switches	5-6
Parking brake	4-5	Battery	5-6
Drive select lever	4-6	OPERATION	6-1
Fuel tank cap	4-7	Starting a cold engine	6-1
Fuel	4-7	Starting a warm engine	6-2
Fuel cock	4-8	Operating the drive select lever and driving in reverse	6-3
		Engine break-in	6-4
		Parking	6-5

Parking on a slope	6-5	Engine oil	8-11
Accessories and loading	6-6	Transmission oil	8-14
RIDING YOUR ATV	7-1	Cleaning the engine and V-belt case air filter elements	8-17
GETTING TO KNOW YOUR ATV	7-2	Cleaning the spark arrester	8-23
RIDE WITH CARE AND GOOD JUDGMENT	7-2	V-belt case drain screw	8-24
BE CAREFUL WHERE YOU RIDE	7-9	Adjusting the carburetor	8-25
TURNING YOUR ATV	7-12	Adjusting the engine idling speed	8-25
CLIMBING UPHILL	7-14	Adjusting the throttle lever free play	8-26
RIDING DOWNHILL	7-16	Valve clearance	8-27
CROSSING A SLOPE	7-17	Brakes	8-27
CROSSING THROUGH SHALLOW WATER	7-18	Checking the front and rear brake shoes	8-27
RIDING OVER ROUGH TERRAIN	7-20	Adjusting the front brake lever free play	8-28
SLIDING AND SKIDDING	7-20	Adjusting the rear brake lever free play	8-32
WHAT TO DO IF	7-22	Drive chain slack	8-34
WHAT TO DO...	7-22	Lubricating the drive chain	8-36
PERIODIC MAINTENANCE AND ADJUSTMENT	8-1	Checking and lubricating the cables	8-37
Owner's manual and tool kit	8-2	Checking and lubricating the front and rear brake levers	8-38
Periodic maintenance chart for the emission control system	8-3	Checking the wheel hub bearings	8-38
General maintenance and lubrication chart	8-5	Lubricating the lower arm pivots	8-39
Checking the spark plug	8-9	Lubricating the front knuckle pivots	8-40
		Lubricating the steering shaft	8-40
		Battery	8-41
		Replacing the fuse	8-44
		Replacing a headlight bulb	8-44

Adjusting a headlight beam	8-46
Replacing the tail/brake light bulb	8-47
Removing a wheel	8-47
Installing a wheel	8-48
Troubleshooting	8-49
Troubleshooting chart	8-50

CLEANING AND STORAGE.....	9-1
Cleaning	9-1
Storage	9-2

SPECIFICATIONS	10-1
----------------------	------

CONSUMER INFORMATION	11-1
Identification numbers	11-1

LOCATION OF THE WARNING AND SPECIFICATION LABELS

Read and understand all of the labels on your ATV. These labels contain important information for safe and proper operation.

Never remove any labels from your ATV. If a label becomes difficult to read or comes off, request a replacement label from your Yamaha dealer.

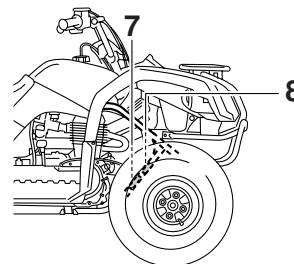
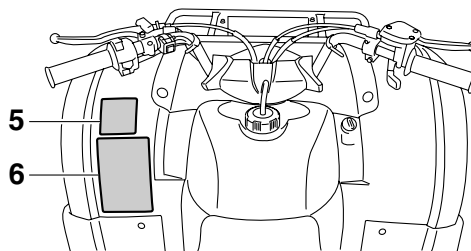
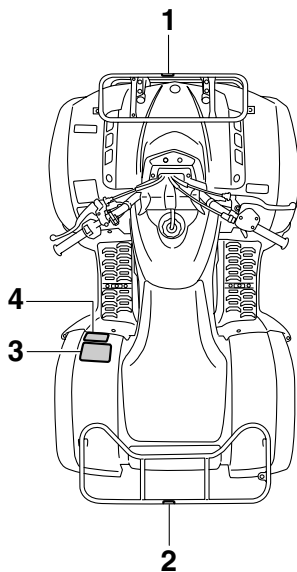

1

1

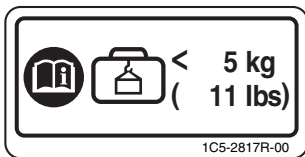

2

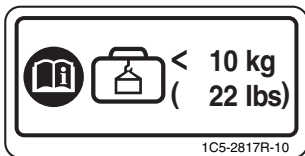

3

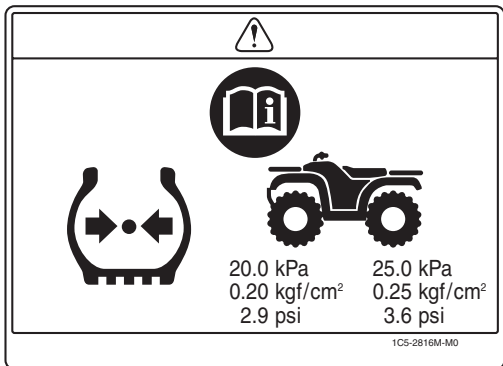

4

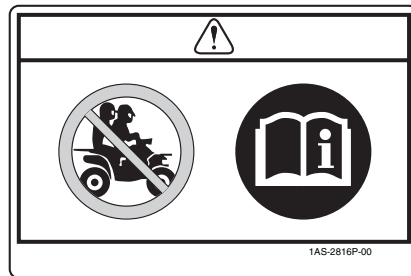

5



7

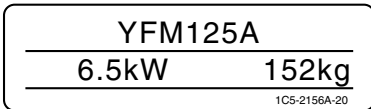

8















6





Familiarize yourself with the following pictograms and read the explanatory text, then make sure to check the pictograms that apply to your model.

1

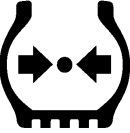
	Read the Owner's manual.		NEVER permit children under age 12 to operate this ATV. Operation of this ATV by children under the age of 12 increases the risk of severe injury or death. Adult supervision required for children under age 16.
	ALWAYS use an approved helmet and protective gear.		NEVER operate this ATV if you are under age 16. Operating this ATV if you are under the age of 16 increases your chance of severe injury or death.
	NEVER permit children under age 6 to operate this ATV. Operation of this ATV by children under the age of 6 increases the risk of severe injury or death. Adult supervision required for children under age 16.		NEVER use on paved roads.
	NEVER permit children under age 10 to operate this ATV. Operation of this ATV by children under the age of 10 increases the risk of severe injury or death. Adult supervision required for children under age 16.		NEVER carry passengers.

	NEVER use with drugs or alcohol.
	NEVER store fuel or flammable liquids.
	This unit contains high-pressure nitrogen gas. Mishandling can cause an explosion. Do not incinerate, puncture or open.
	Use unleaded gasoline only.
	Measure the tire pressure when the tires are cold.

 <small>** kPa ** kPa</small> <small>** kgf/cm² ** kgf/cm²</small> <small>** psi ** psi</small>	<p>Adjust the tire pressure. Improper tire pressure can cause loss of control. Loss of control can result in severe injury or death.</p>
	<p>Turning the ATV in 4WD-LOCK ("DIFF.LOCK") takes more effort. Operate at a slow speed and allow extra time and distance for maneuvers to avoid loss of control.</p>
	<p>This pictogram shows the loading limits and/or maximum load capacity for this ATV. Follow all load limits and other loading guidelines in this manual. Load may include the driver, passenger, human protective gear, accessories, goods, luggage, and all other load related items. Make sure you do not exceed the load limits. Overloading can cause loss of control. Loss of control can result in severe injury or death.</p>



This pictogram shows trailer Hitch Tow weight limit. (Combined weight of the trailer and all cargo in the trailer.)
Overloading can cause loss of control.
Loss of control can result in severe injury or death.



This pictogram shows trailer Hitch Tongue weight limit. (Weight on the trailer tongue.)
Overloading can cause loss of control.
Loss of control can result in severe injury or death.

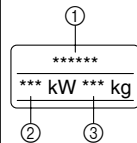

- ① Model Name
- ② Max. Power
- ③ Mass In Running Order

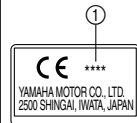

- ① Year of construction



SAFETY INFORMATION

AN ATV IS NOT A TOY AND CAN BE HAZARDOUS TO OPERATE.

An ATV handles differently from other vehicles, including motorcycles and cars. A collision or roll-over can occur quickly, even during routine maneuvers such as turning and riding on hills or over obstacles, if you fail to take proper precautions.

SEVERE INJURY OR DEATH can result if you do not follow these instructions:

- Read this manual and all labels carefully and follow the operating procedures described.
- Never operate an ATV without proper training or instruction.
- Always follow the age recommendation:
 - A child under 16 years old should never operate an ATV with engine size greater than 90 cc.
- Never allow a child under age 16 to operate an ATV without adult supervision, and never allow continued use of an ATV by a child if he or she does not have the abilities to operate it safely.

- Never carry a passenger on an ATV.
- Always avoid operating an ATV on any paved surfaces, including sidewalks, driveways, parking lots and paved streets.
- Never operate an ATV on any paved street, paved road or motorway.
- Watch carefully for other vehicles when operating on unpaved public streets or roads. Make sure you know your country's laws and regulations before you ride on unpaved public streets or roads.
- Never operate an ATV without wearing an approved motorcycle helmet that fits properly. You should also wear eye protection (goggles or face shield), gloves, boots, a long-sleeved shirt or a jacket, and long pants.
- Never consume alcohol or drugs before or while operating this ATV.
- Never operate at speeds too fast for your skills or the riding conditions. Always go at a speed that is proper for the terrain, visibility, operating conditions, and your experience.
- Never attempt wheelies, jumps, or other stunts.

- Always inspect your ATV each time you use it to make sure it is in safe operating condition. Always follow the inspection and maintenance procedures and schedules described in this manual.
- Always keep both hands on the handlebars and both feet on the footboards of the ATV during operation.
- Always go slowly and be extra careful when operating on unfamiliar terrain. Always be alert to changing terrain conditions when operating the ATV.
- Never operate on excessively rough, slippery or loose terrain until you have learned and practiced the skills necessary to control the ATV on such terrain. Always be especially cautious on these kinds of terrain.
- Always follow proper procedures for turning as described in this manual. Practice turning at low speeds before attempting to turn at faster speeds and never turn at excessive speeds.
- Never operate the ATV on hills too steep for the ATV or for your abilities. Practice on smaller hills before attempting larger hills.
- Always follow proper procedures for climbing hills as described in this manual. Check the terrain carefully before you start up any hill. Never climb hills with excessively slippery or loose surfaces. Shift your weight forward. Never open the throttle suddenly. Never go over the top of a hill at high speed.
- Always follow proper procedures for going down hills and for braking on hills as described in this manual. Check the terrain carefully before you start down any hill. Shift your weight backward. Never go down a hill at high speed. Avoid going down a hill at an angle that would cause the vehicle to lean sharply to one side. Go straight down the hill where possible.
- Always follow proper procedures for crossing the side of a hill as described in this manual. Avoid hills with excessively slippery or loose surfaces. Shift your weight to the uphill side of the ATV. Never attempt to turn the ATV around on any hill until you have mastered the turning technique described in this manual on level ground. Avoid crossing the side of a steep hill if possible.
- Always use proper procedures if you stall or roll backwards when climbing a hill. To avoid stalling, maintain a steady speed when climbing a

hill. If you stall or roll backwards, follow the special procedure for braking described in this manual. Dismount on the uphill side or to a side if pointed straight uphill. Turn the ATV around and remount, following the procedure described in this manual.

- Always check for obstacles before operating in a new area.
- Never attempt to operate over large obstacles, such as large rocks or fallen trees. Always follow proper procedures when operating over obstacles as described in this manual.
- Always be careful when skidding or sliding. Learn to safely control skidding or sliding by practicing at low speeds and on level, smooth terrain. On extremely slippery surfaces, such as ice, go slowly and be very cautious in order to reduce the chance of skidding or sliding out of control.
- Never operate an ATV in fast flowing water or in water deeper than that recommended in this manual. Remember that wet brakes may have reduced stopping ability. Test your brakes after leaving water. If necessary, apply them several times to let friction dry out the linings.

- Always be sure there are no obstacles or people behind you when you operate in reverse. When it is safe to proceed in reverse, go slowly.
- Always use the size and type of tires specified in this manual.
- Always maintain proper tire pressure as described in this manual.
- Never modify an ATV through improper installation or use of accessories.
- Never exceed the stated load capacity for an ATV. Cargo should be properly distributed and securely attached. Reduce speed and follow instructions in this manual for carrying cargo. Allow greater distance for braking.

EWB00072

WARNING

Avoid Carbon Monoxide Poisoning

All engine exhaust contains carbon monoxide, a deadly gas. Breathing carbon monoxide can cause headaches, dizziness, drowsiness, nausea, confusion, and eventually death.

Carbon Monoxide is a colorless, odorless, tasteless gas which may be present even if you do not see or smell any engine exhaust. Deadly levels of carbon monoxide can collect rapidly and you can quickly be overcome and unable

to save yourself. Also, deadly levels of carbon monoxide can linger for hours or days in enclosed or poorly ventilated areas. If you experience any symptoms of carbon monoxide poisoning, leave the area immediately, get fresh air, and **SEEK MEDICAL TREATMENT**.

- Do not run engine indoors. Even if you try to ventilate engine exhaust with fans or open windows and doors, carbon monoxide can rapidly reach dangerous levels.
- Do not run engine in poorly ventilated or partially enclosed areas such as barns, garages, or carports.
- Do not run engine outdoors where engine exhaust can be drawn into a building through openings such as windows and doors.

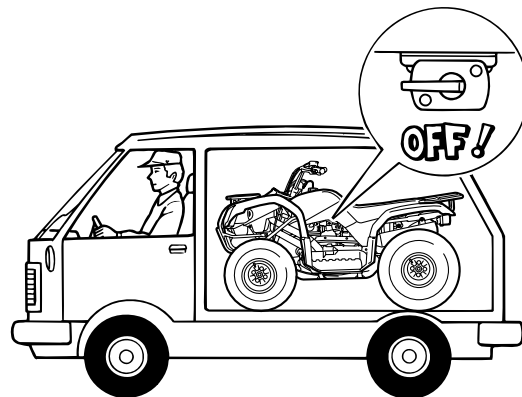

EWB02591

⚠ WARNING

When transporting the ATV in another vehicle, be sure it is kept upright and that the fuel cock is in the “OFF” position. Otherwise, fuel may leak out of the carburetor or fuel tank.

DESCRIPTION

EBU17690

Left view

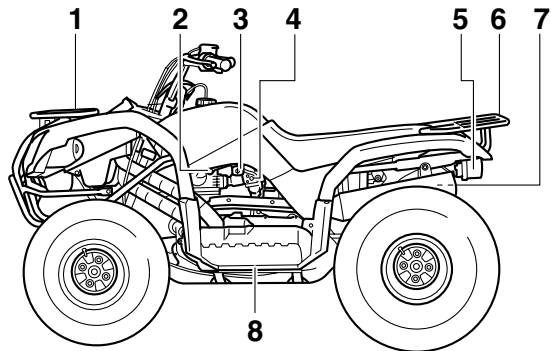

1. Front carrier
2. Starter (choke)
3. Fuel cock
4. Throttle stop screw
5. Tail/brake light
6. Rear carrier
7. Spark arrester
8. Footboard

EBU17700

Right view

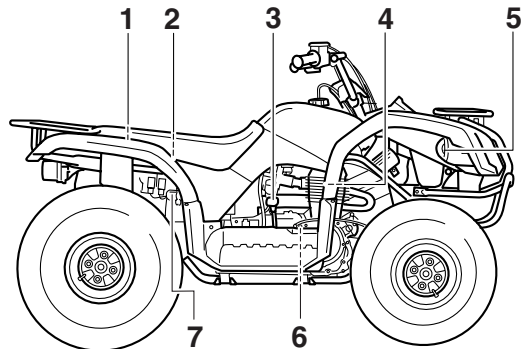

1. Owner's tool kit
2. Battery
3. Drive select lever
4. Spark plug
5. Headlight
6. Engine oil filler cap
7. Fuse

Controls and instruments

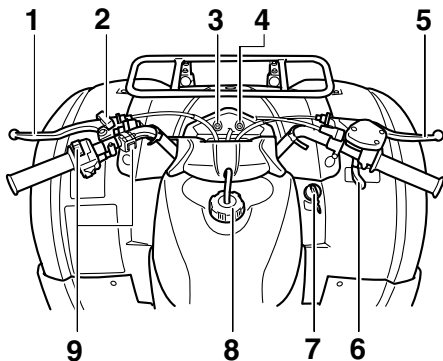

1. Rear brake lever
2. Parking brake lock plate
3. Reverse indicator light
4. Neutral indicator light
5. Front brake lever
6. Throttle lever
7. Main switch
8. Fuel tank cap
9. Handlebar switches

TIP _____
The ATV you have purchased may differ slightly from the figures shown in this manual.

INSTRUMENT AND CONTROL FUNCTIONS

EBU17760

Main switch

The positions of the main switch are as follows:

ON

All electrical systems are supplied with power. The headlights and taillight come on when the light switch is on, and the engine can be started. The key cannot be removed.

OFF

All electrical systems are off. The key can be removed.

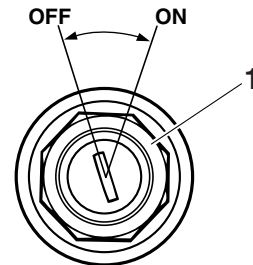

1. Main switch

Indicator lights

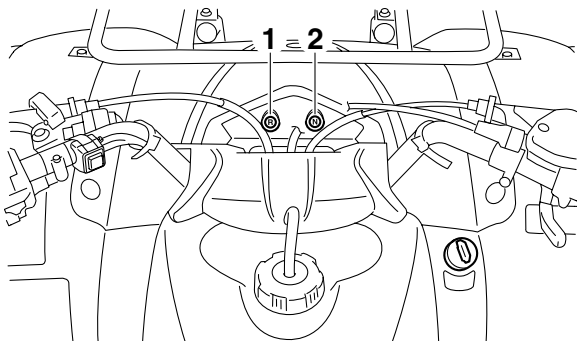

1. Reverse indicator light “R”
2. Neutral indicator light “N”

Neutral indicator light “N”





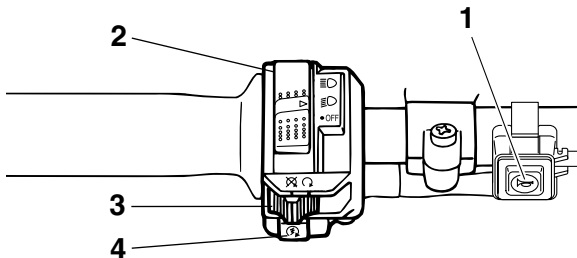

This indicator light comes on when the transmission is in the neutral position.

Reverse indicator light “R”



This indicator light comes on when the transmission is in the reverse position.

Handlebar switches



1. Horn switch “”
2. Light switch “ /  / OFF”
3. Engine stop switch “ / ”
4. Start switch “”

Engine stop switch “ / ”

Set this switch to “” before starting the engine. The engine stop switch controls the ignition and stops the engine when it is running. Use this switch to stop the engine in an emergency situation. The engine will not start or run when this switch is set to “”.



EBU18101

Start switch “”

Push this switch to crank the engine with the starter. See the starting instructions on page 6-1 prior to starting the engine.

EBU18154

Light switch “ / / OFF”

Set this switch to “” to turn on the low beams and the taillight. Set the switch to “” to turn on the high beams and the taillight. Set the switch to “OFF” to turn off all the lights.

ECB00043

NOTICE

Do not use the headlights with the engine turned off for an extended period of time, otherwise the battery may discharge to the point that the starter motor will not operate properly. If this should happen, remove the battery and recharge it. (See page 8-41.)

EBU18170

Horn switch “”

Press the switch to sound the horn.

EBU18282

Throttle lever

Once the engine is running, pushing the throttle lever will increase the engine speed.

Regulate the speed of the ATV by varying the throttle position. Because the throttle is spring-loaded, the ATV will decelerate, and the engine will return to an idle any time the throttle lever is released.

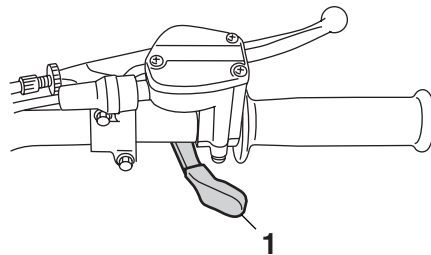

1. Throttle lever

Before starting the engine, check the throttle to be sure it is operating smoothly. Make sure it returns to the idle position as soon as the lever is released.

Speed limiter

Your ATV is equipped with an adjustable speed limiter. The speed limiter keeps the throttle from fully opening, even when the throttle lever is pushed to the maximum.

1. Loosen the locknut.
2. To increase the maximum engine power available and the maximum speed of the ATV, turn the adjusting screw in direction (a). To decrease the maximum engine power available and the maximum speed of the ATV, turn the adjusting screw in direction (b). Do not turn the adjusting screw out more than 12 mm (0.47 in) or the throttle cable could be damaged. Always make sure the throttle lever free play is adjusted to 1.0–3.0 mm (0.04–0.12 in). (See page 8-26.) **WARNING! Improper adjustment of the speed limiter and throttle could cause throttle cable damage or improper throttle operation. You could lose control, resulting in an accident.** [EWB00241]

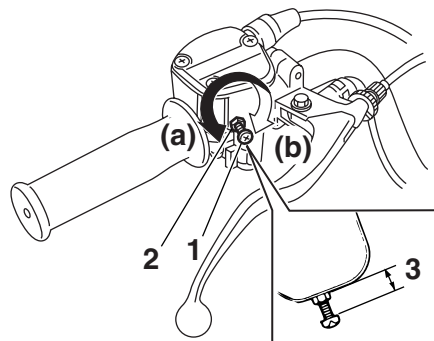

1. Adjusting screw
 2. Locknut
 3. No more than 12 mm (0.47 in)
3. Tighten the locknut.

EBU18391

Front brake lever

The front brake lever is located on the right handlebar. To apply the front brake, pull the brake lever toward the handlebar grip.

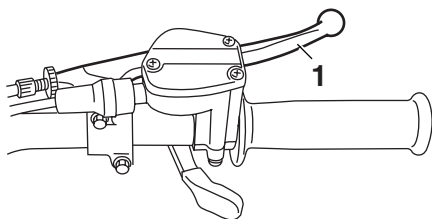

1. Front brake lever

EBU18401

Rear brake lever

The rear brake lever is located on the left handlebar. To apply the rear brake, pull the brake lever toward the handlebar grip.

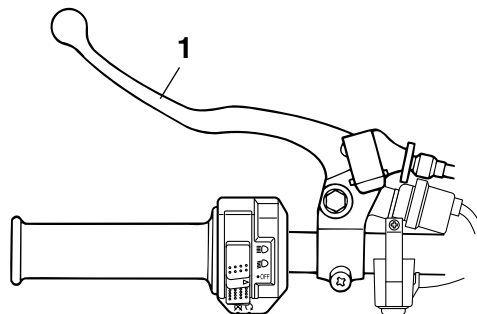

1. Rear brake lever

EBU18461

Parking brake

Use the parking brake before starting the engine or after parking the ATV, especially on a slope. Apply the rear brake lever and push down the lock plate to apply the parking brake. Squeeze the rear brake lever to release the parking brake.

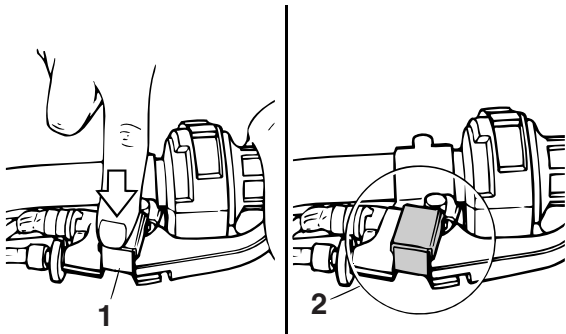

1. Parking brake lock plate
2. Locked position

EWB00220

⚠ WARNING

- **Always set the parking brake before starting the engine. The ATV could start moving unexpectedly if the parking brake is not applied. This could cause loss of control or a collision.**
- **Always be sure you have released the parking brake before you begin to ride. The brake could overheat if you ride the ATV without releasing the parking brake. You could lose**

braking performance which could cause an accident. You could also wear out the brakes prematurely.

EBU18581

Drive select lever

The drive select lever is used to shift your ATV into the forward, neutral and reverse positions. See the “Operating the drive select lever and driving in reverse” section on page 6-3 for the drive select lever operation.

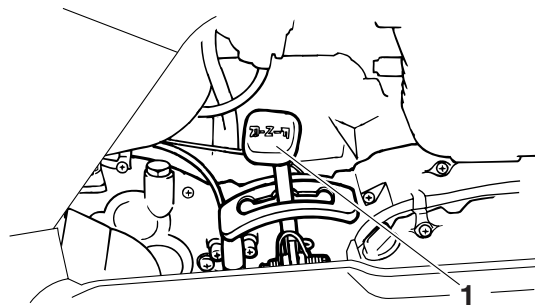

1. Drive select lever

Fuel tank cap

Remove the fuel tank cap by turning it counter-clockwise.

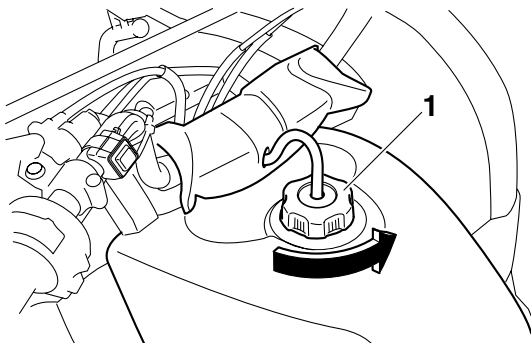

1. Fuel tank cap

Fuel

Make sure there is sufficient gasoline in the tank.



Gasoline and gasoline vapors are extremely flammable. To avoid fires and explosions and to reduce the risk of injury when refueling, follow these instructions.

1. Before refueling, turn off the engine and be sure that no one is sitting on the vehicle. Never refuel while smoking, or while in the vicinity of sparks, open flames, or other sources of ignition such as the pilot lights of water heaters and clothes dryers.
2. Do not overfill the fuel tank. When refueling, be sure to insert the pump nozzle into the fuel tank filler hole. Stop filling when the fuel reaches the bottom of the filler tube. Because fuel expands when it heats up, heat from the engine or the sun can cause fuel to spill out of the fuel tank.

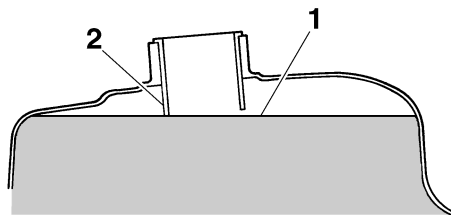

1. Maximum fuel level
2. Fuel tank filler tube

Recommended fuel:

Regular unleaded gasoline only with a research octane number of 91 or higher

Fuel tank capacity:

7.0 L (1.85 US gal, 1.54 Imp.gal)

Fuel reserve amount:

1.3 L (0.34 US gal, 0.29 Imp.gal)

3. Wipe up any spilled fuel immediately.

NOTICE: Immediately wipe off spilled fuel with a clean, dry, soft cloth, since fuel may deteriorate painted surfaces or plastic parts. [ECB00981]

4. Turn the fuel tank cap fully clockwise to make sure it is securely closed.

EWB02531

⚠ WARNING

Gasoline is poisonous and can cause injury or death. Handle gasoline with care. Never siphon gasoline by mouth. If you should swallow some gasoline or inhale a lot of gasoline vapor, or get some gasoline in your eyes, see your doctor immediately. If gasoline spills on your skin, wash with soap and water. If gasoline spills on your clothing, change your clothes.

ECB00070

NOTICE

Use only unleaded gasoline. The use of leaded gasoline will cause severe damage to internal engine parts, such as the valves and piston rings, as well as to the exhaust system.

Your Yamaha engine has been designed to use regular unleaded gasoline with a research octane number of 91 or higher. If knocking (or pinging) occurs, use a gasoline of a different brand. Use of unleaded fuel will extend spark plug life and reduce maintenance costs.

EBU18820

Fuel cock

The fuel cock supplies fuel from the tank to the carburetor while also filtering it.

The fuel cock lever positions are explained as follows and shown in the illustrations.

OFF

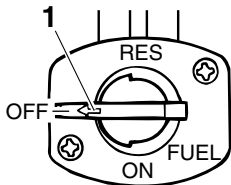

1. Arrow mark positioned over "OFF"

With the fuel cock lever in this position, fuel will not flow. Always turn the fuel cock lever to this position when the engine is not running.

ON

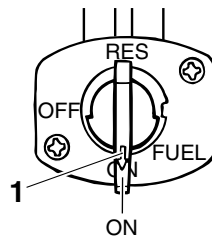

1. Arrow mark positioned over "ON"

With the fuel cock lever in this position, fuel flows to the carburetor. Turn the fuel cock lever to this position when starting the engine and riding.

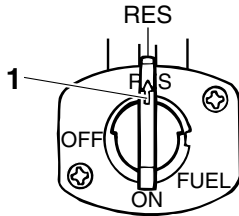

1. Arrow mark positioned over "RES"

This indicates reserve. With the fuel cock lever in this position, the fuel reserve is made available. Turn the fuel cock lever to this position if you run out of fuel while riding. When this occurs, refuel as soon as possible and be sure to turn the fuel cock lever back to "ON"!

EBU18840

Starter (choke)

Starting a cold engine requires a richer air-fuel mixture, which is supplied by the starter (choke). Move the starter (choke) in direction (a) to turn on the starter (choke).

Move the starter (choke) in direction (b) to turn off the starter (choke).

See the "Starting a cold engine" section on page 6-1 for proper operation.

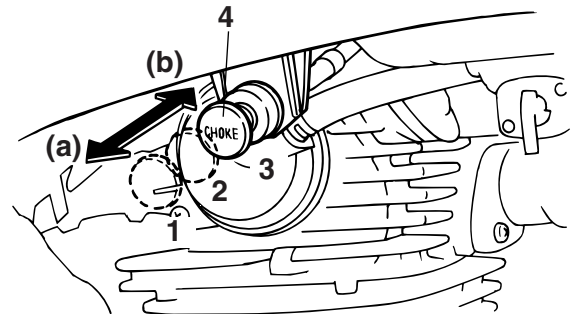

1. Fully open
2. Half open
3. Closed
4. Starter (choke)

EBU18881

Seat

To remove the seat

Pull the seat lock lever upward and pull up the seat at the rear.

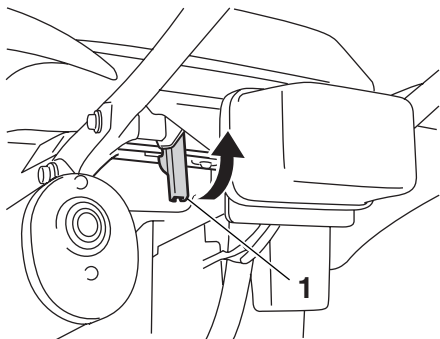

1. Seat lock lever

To install the seat

Insert the projections on the front of the seat into the seat holders and push down on the seat at the rear. Make sure that the seat is securely fitted.

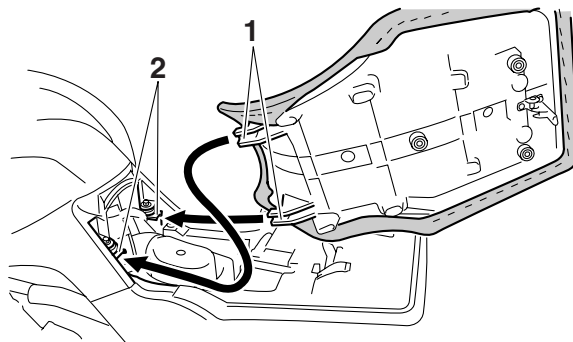

1. Projection
2. Seat holder

EBU18962

Front carrier

- Do not exceed the load limit of 5.0 kg (11 lb) for the front carrier.
- Do not exceed the maximum load of 105.0 kg (231 lb) for the ATV.

EBU18972

Rear carrier

- Do not exceed the load limit of 10.0 kg (22 lb) for the rear carrier.
- Do not exceed the maximum load of 105.0 kg (231 lb) for the ATV.

PRE-OPERATION CHECKS

Inspect your vehicle each time you use it to make sure the vehicle is in safe operating condition. Always follow the inspection and maintenance procedures and schedules described in the Owner's Manual.

EWB00481

**5**

Failure to inspect or maintain the vehicle properly increases the possibility of an accident or equipment damage. Do not operate the vehicle if you find any problem. If a problem cannot be corrected by the procedures provided in this manual, have the vehicle inspected by a Yamaha dealer.

Before using this vehicle, check the following points:

ITEM	ROUTINE	PAGE
Fuel	<ul style="list-style-type: none"> • Check fuel level in fuel tank, and add recommended fuel if necessary. • Check fuel line for leakage. Correct if necessary. 	4-7, 5-3
Engine oil	<ul style="list-style-type: none"> • Check oil level in engine, and add recommended oil to specified level if necessary. • Check ATV for oil leakage. Correct if necessary. 	5-3, 8-11
Transmission oil	<ul style="list-style-type: none"> • Check oil level in transmission case, and add recommended oil to specified level if necessary. • Check ATV for oil leakage. Correct if necessary. 	5-3, 8-14
Front brake	<ul style="list-style-type: none"> • Check operation, and correct if necessary. • Lubricate cable if necessary. • Check lever free play, and adjust if necessary. 	5-3, 8-27, 8-28

ITEM	ROUTINE	PAGE
Rear brake	<ul style="list-style-type: none"> • Check operation, and correct if necessary. • Lubricate cable if necessary. • Check lever free play, and adjust if necessary. 	5-3, 8-27, 8-32
Throttle lever	<ul style="list-style-type: none"> • Make sure that operation is smooth. Lubricate cable and lever housing if necessary. • Check lever free play, and adjust if necessary. 	5-3, 8-26
Control cables	<ul style="list-style-type: none"> • Make sure that operation is smooth. Lubricate if necessary. 	8-37
Drive chain	<ul style="list-style-type: none"> • Check chain slack, and adjust if necessary. • Check chain condition. Lubricate if necessary. 	5-3, 8-34, 8-36
Wheels and tires	<ul style="list-style-type: none"> • Check wheel condition, and replace if damaged. • Check tire condition and tread depth. Replace if necessary. • Check air pressure. Correct if necessary. 	5-3
Brake levers	<ul style="list-style-type: none"> • Make sure that operation is smooth. Lubricate lever pivoting points if necessary. 	8-38
Chassis fasteners	<ul style="list-style-type: none"> • Make sure that all nuts, bolts and screws are properly tightened. 	5-6
Instruments, lights and switches	<ul style="list-style-type: none"> • Check operation, and correct if necessary. 	5-6
Battery	<ul style="list-style-type: none"> • Check electrolyte level. Fill with distilled water if necessary. 	5-6, 8-41

EBU19541

Fuel

Make sure that there is sufficient fuel in the tank. (See page 4-7.)

EBU19560

Engine oil

Make sure that the engine oil is at the specified level. Add oil as necessary. (See page 8-11.)

5

EBU19580

Transmission oil

Make sure that the transmission oil is at the specified level. Add oil as necessary. (See page 8-14.)

EBU19652

Front and rear brakes

Brake levers

- Check for correct free play in the brake levers. If the free play is incorrect, adjust it. (See pages 8-28 and 8-32.)
- Check operation of the levers. They should move smoothly and there should be a firm feeling when the brake is applied. If not, have the ATV checked by a Yamaha dealer.

Brake operation

Test the brakes at slow speed after starting out to make sure they are working properly. If the brakes do not provide proper braking performance, check the brake shoes for wear. (See page 8-27.)

EBU19761

Throttle lever

Check the operation of the throttle lever. It must open smoothly and spring back to the idle position when released. Have a Yamaha dealer correct if necessary.

EBU19770

Drive chain

Check the condition of the drive chain and check the drive chain slack. Lubricate and adjust the drive chain as necessary. (See page 8-34.)

EBU19794

Tires

Check tire pressure regularly to make sure it is at the recommended specifications. Also check for wear and damage.

Tire pressure

Use the low-pressure tire gauge to check and adjust tire pressures when the tires are cold. Tire pressures must be equal on both sides.

WARNING! Operation of this vehicle with improper tire pressure may cause severe injury or death from loss of control or rollover. Tire pressure below the minimum specified could also cause the tire to dislodge from the rim under severe riding conditions. [EWB02541] Set tire pressures to the following specifications:

Recommended tire pressure:

Front

20.0 kPa (0.200 kgf/cm², 2.9 psi)

Rear

25.0 kPa (0.250 kgf/cm², 3.6 psi)

Minimum tire pressure:

Front

17.0 kPa (0.170 kgf/cm², 2.5 psi)

Rear

22.0 kPa (0.220 kgf/cm², 3.2 psi)

Maximum tire seating pressure:

Front

250 kPa (2.5 kgf/cm², 36 psi)

Rear

250 kPa (2.5 kgf/cm², 36 psi)

The low-pressure tire gauge is included as standard equipment. Make two measurements of the tire pressure and use the second reading. Dust or dirt in the gauge could cause the first reading to be incorrect.

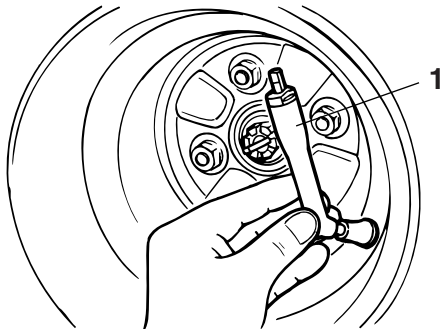

1. Low-pressure tire gauge

Tire wear limit

When the tire groove decreases to 3 mm (0.12 in) due to wear, replace the tire.

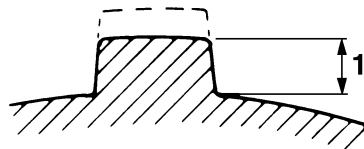

1. Tire wear limit

Tire information

This ATV is equipped with tubeless tires with valves.

EWB02551



Use of improper tires on this ATV may cause loss of control, increasing your risk of an accident.

After extensive tests, only the tires listed below have been approved for this model by Yamaha Motor Co., Ltd.

Front:

Manufacturer/model:
DUNLOP/KT536A

Size:
AT20 x 7-8

Type:
Tubeless

Rear:

Manufacturer/model:
DUNLOP/KT537A

Size:
AT22 x 10-8

Type:
Tubeless

EBU19850

Instruments, lights and switches

Check that all instruments, lights and switches are working properly. Correct if necessary.

EBU19860

Battery

Check the fluid level in the battery. Fill with distilled water if necessary. (See page 8-41.)

Aftermarket tires and rims

The tires and rims that came with your ATV were designed to match the performance capabilities and to provide the best combination of handling, braking, and comfort. Other tires, rims, sizes, and combinations may not be appropriate.

EBU19840

Chassis fasteners

Make sure that all nuts, bolts and screws are properly tightened.

OPERATION

Read the Owner's Manual carefully before riding the ATV. If there is a control or function you do not understand, ask your Yamaha dealer.

EWB00631

WARNING

Read the Owner's Manual carefully to become familiar with all controls in order to help prevent any loss of control, which could cause an accident or injury.

6

EBU29722

Starting a cold engine

ECB00150

NOTICE

See the "Engine break-in" section on page 6-4 prior to operating the engine for the first time.

1. Set the parking brake.
2. Turn the fuel cock to "ON".
3. Turn the key to "ON" and the engine stop switch to "○".

4. Shift the drive select lever into the neutral position. The neutral indicator light should come on. If the indicator light does not come on, have a Yamaha dealer check the electrical circuit.

TIP

The engine can be started only when the drive select lever is in the neutral position.

5. Use the starter (choke) in reference to the figure:
 - Position (1):**
Cold engine start with ambient temperature below 5 °C (40 °F).
 - Position (2):**
Cold engine start with ambient temperature between 0 °C (30 °F) and 30 °C (90 °F).
 - Position (3):**
Cold engine start with ambient temperature above 25 °C (80 °F).

Ambient temp./starter (choke) position

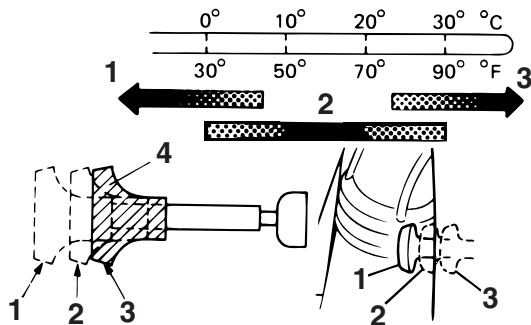

1. Fully open
2. Half open
3. Closed
4. Starter (choke)

6. Completely close the throttle lever and start the engine by pushing the start switch.

TIP

If the engine fails to start, release the start switch, then push it again. Pause a few seconds before the next attempt. Each cranking should be as short as possible to preserve battery energy. Do not crank the engine more than 10 seconds on each attempt.

7. If the engine is started with the starter (choke) in position (1), the starter (choke) should be returned to position (2) to warm up the engine. If the engine is started with the starter (choke) in position (2), keep the starter (choke) in this position to warm up the engine.
8. Continue warming up the engine until it idles smoothly, then return the starter (choke) to position (3) before riding.

TIP

The engine is warm when it responds normally to the throttle with the starter (choke) turned off.

ECB00163

NOTICE

For maximum engine life, never accelerate hard when the engine is cold!

EBU20291

Starting a warm engine

Follow the same procedure as for starting a cold engine, with the exception that the starter (choke) is not required when the engine is warm. Instead, start the engine with the throttle slightly open.

Operating the drive select lever and driving in reverse

ECB00170

NOTICE

Before shifting, stop the ATV, otherwise the transmission may be damaged.

Shifting: Forward

1. Bring the ATV to a complete stop.
2. Shift from neutral to forward and vice versa by moving the drive select lever along the shift guide.

TIP

Make sure that the drive select lever is completely shifted into position.

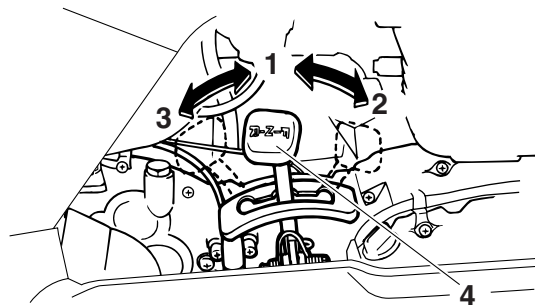

1. Neutral "N"
2. Forward "F"
3. Reverse "R"
4. Drive select lever

3. Open the throttle lever gradually.

Shifting: Reverse

EVB00720

WARNING

Improper operation in reverse could make you hit an obstacle or even a person behind you, resulting in serious injury. When you shift into reverse, make sure there are no people or obstacles behind you. When it is safe to proceed, go slowly.

1. Bring the ATV to a complete stop.
2. Apply the parking brake.
3. Shift from neutral to reverse and vice versa by moving the drive select lever along the shift guide.

TIP

When in reverse, the reverse indicator light should come on. If the indicator light does not come on, have a Yamaha dealer check the electrical circuit.

4. Check behind for people or obstacles, and then release the parking brake.
5. Open the throttle lever gradually and continue to watch to the rear while backing.

TIP

If the drive select lever is shifted into reverse while the engine is running, the engine will stop unless the rear brake lever or parking brake is applied.

EBU20682

Engine break-in

TIP

- For ATVs equipped with an odometer or an hour meter, follow the figures given in km (mi) or the figures given in hours.

- For ATVs not equipped with an odometer or hour meter, follow the figures given in hours.
-

There is never a more important period in the life of your engine than the first 320 km (200 mi) or 20 hours of riding. For this reason, you should read the following material carefully.

Since the engine is brand new, do not put an excessive load on it for the first 320 km (200 mi) or 20 hours. The various parts in the engine wear and polish themselves to the correct operating clearances. During this period, prolonged full-throttle operation or any condition that might result in engine overheating must be avoided.

0–160 km (0–100 mi) or 0–10 hours

Avoid prolonged operation above 1/2 throttle. Vary the speed of the ATV regularly. Do not operate it at one set throttle position.

160–320 km (100–200 mi) or 10–20 hours

Avoid prolonged operation above 3/4 throttle. Rev the engine freely, but do not use full throttle at any time.

320 km (200 mi) or 20 hours and beyond

The ATV can now be operated normally.

NOTICE

If any engine trouble should occur during the engine break-in period, immediately have a Yamaha dealer check the ATV.

Parking

When parking the ATV, apply the rear brake lever, shift the drive select lever into the forward position, stop the engine, apply the parking brake, and then turn the fuel cock to "OFF".

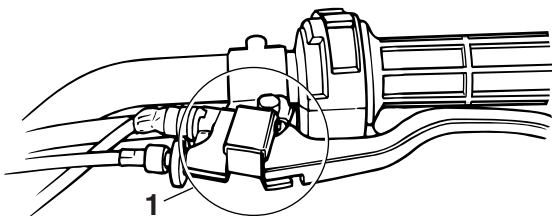
6

1. Locked position

Parking on a slope**! WARNING**

Avoid parking on hills or other inclines. Parking on a hill or other incline could cause the ATV to roll out of control, increasing the chance of an accident. If you must park on an incline, place the ATV transversely across the incline, shift the drive select lever to the forward position, stop the engine, apply the parking brake, and then block the front and rear wheels with rocks or other objects.

Never park the ATV on hills that are too steep to walk up easily.

1. With the transmission in the forward position, bring the ATV to a stop by applying the brakes.
2. Stop the engine.
3. With the rear brake applied, apply the parking brake.

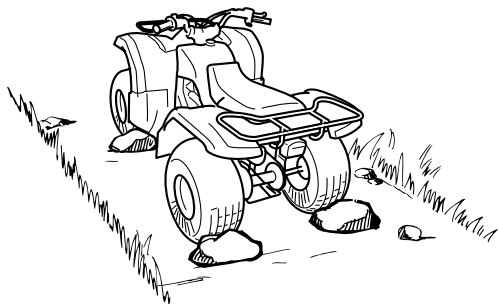

EBU20910

Accessories and loading

EBU20921

Genuine Yamaha Accessories

Choosing accessories for your ATV is an important decision. Genuine Yamaha Accessories, which are available only from a Yamaha dealer, have been designed, tested, and approved by Yamaha for use on your ATV. Many companies with no connection to Yamaha manufacture parts and accessories or offer other modifications for Yamaha vehicles. Yamaha is not in a position to test the products that these aftermarket companies produce. Therefore, Yamaha can neither endorse nor

recommend the use of accessories not sold by Yamaha or modifications not specifically recommended by Yamaha, even if sold and installed by a Yamaha dealer.

Aftermarket parts, accessories, and modifications

While you may find aftermarket products similar in design and quality to genuine Yamaha Accessories, recognize that some aftermarket accessories or modifications are not suitable because of potential safety hazards to you or others. Installing aftermarket products or having other modifications performed to your ATV that change any of the vehicle's design or operation characteristics can put you and others at greater risk of serious injury or death. You are responsible for injuries related to changes in the vehicle.

Keep the following in mind when considering an accessory or operating an ATV which has accessories.

- Accessories should be rigidly and securely mounted. An accessory which can shift position or come off while you are riding could affect your ability to control the ATV.

- Do not mount an accessory where it could interfere with your ability to control the ATV. Examples include (but are not limited to) a heavy or bulky object attached to the handlebars which could make steering difficult, an accessory that limits your ability to move around on the seat, or one that limits your view.
- Use extra caution when riding an ATV with accessories. The ATV may handle differently than it does without accessories.

EBU21081

6

Loading

EWB00820



Never exceed the stated load capacity for this ATV. Overloading this ATV or carrying or towing cargo improperly could cause changes in ATV handling which could lead to an accident. Cargo should be properly distributed and securely attached. Reduce speed when carrying cargo or pulling a trailer. Allow greater distance for braking.

As originally equipped, this ATV is not designed to tow a trailer. If you choose to add accessories so that you can tow a trailer, you must use common

sense and good judgment as the stability and handling of an ATV can be changed. When adding accessories, keep the following points in mind:

- Never exceed the weight limits shown. An overloaded ATV can be unstable.

MAXIMUM LOADING LIMIT

ATV loading limit (total weight of rider, cargo, accessories, and tongue):

105.0 kg (231 lb)

Front carrier:

5.0 kg (11 lb)

Rear carrier:

10.0 kg (22 lb)

- If you are carrying cargo and towing a trailer, include the tongue weight in the maximum ATV load limit.
- Load cargo on the carriers as close to the center of the ATV as possible. Put cargo at the rear of the front carrier, at the front of the rear carrier, and center it.
- Tie down cargo securely to the carriers. Make sure cargo in the trailer cannot move around. A shifting load can cause an accident.
- Make sure the load does not interfere with controls or your ability to see where you are going.

- Ride more slowly than you would without a load. The more weight you carry, the slower you should go.
- Allow more braking distance. A heavier ATV takes longer to stop.
- Avoid making sharp turns unless at very slow speeds.
- Avoid hills and rough terrain. Choose terrain carefully. Added weight affects the stability and handling of the ATV.

RIDING YOUR ATV

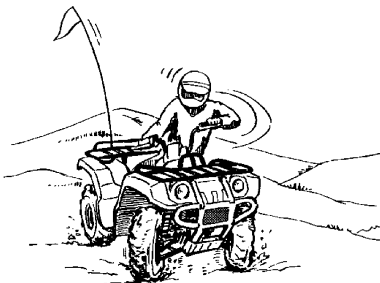
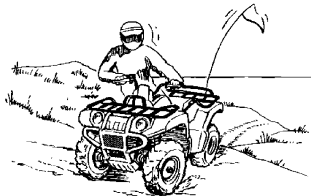
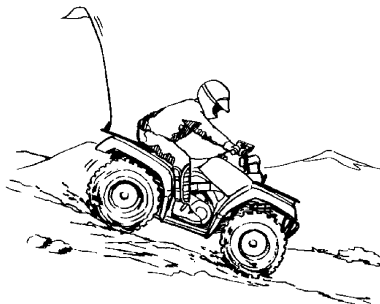
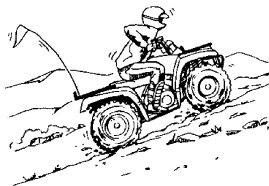
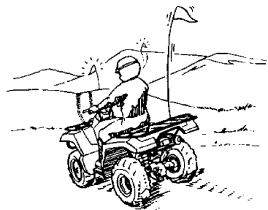

GETTING TO KNOW YOUR ATV

This ATV is for recreation and utility use. This section, Riding your ATV, provides general ATV riding instructions for recreational riding. The skills and techniques described in this section, however, are appropriate for all types of riding. Riding your ATV requires special skills acquired through practice over a period of time. Take the time to learn the basic techniques well before attempting more difficult maneuvers.

Riding your new ATV can be a very enjoyable activity, providing you with hours of pleasure. But it is essential to familiarize yourself with the operation of the ATV to achieve the skill necessary to enjoy riding safely. Before you begin to ride, be sure you have read this Owner's Manual completely and understand the operation of the controls. Pay particular attention to the safety information on pages 2-1–2-4. Also read all warning and notice labels on your ATV.

RIDE WITH CARE AND GOOD JUDGMENT

Get training if you are inexperienced.

EWB01381



- **Do not operate this ATV or allow anyone else to operate it without proper instruction. The risk of an accident is greatly increased if the operator does not know how to operate the ATV properly in different situations and on different types of terrain.**
- **Do not operate this ATV at speeds too fast for your skills or the conditions, as this increases your chances of losing control of the ATV and an accident. Always go at a speed that is proper for the terrain, visibility and operating conditions, and your experience.**

Beginning and inexperienced operators should regularly practice the skills and the operating techniques described in this Owner's Manual.

Riding your ATV requires skills acquired through practice over a period of time.

Do not attempt to operate at maximum performance until you are totally familiar with the ATV's handling and performance characteristics. Take the time to learn the basic techniques well before attempting more difficult maneuvers. Become familiar with this ATV at slow speeds first, even if you are an experienced operator.

Not recommended for children under 16 years of age.

EWB01390

7

⚠ WARNING

A child under 16 should never operate an ATV with engine size greater than 90 cc. Use by children of ATVs that are not recommended for their age can lead to severe injury or death of the child.



This ATV is designed to carry the operator and cargo only – passengers prohibited.

The long seat is to allow the operator to shift position as needed during operation. It is not for carrying passengers. **WARNING! Never carry a passenger. Carrying a passenger on this ATV greatly reduces your ability to balance and control this ATV. You could have an accident, resulting in severe injury or death to you and/or your passenger.** [EWB01401]



Apparel

Always wear the following to reduce risk of injury in an accident:

- Approved motorcycle helmet that fits properly
- Eye protection (goggles, helmet face shield, or protective eyewear)
- Over-the-ankle boots, gloves, long-sleeved shirt or jacket, and long pants

An approved helmet and other personal protective equipment can reduce the severity of injuries in an accident. **WARNING! Operating without an approved motorcycle helmet increases your chances of a severe head injury or death in the event of an accident.** [EWB01411]

Wear eye protection when operating your ATV to reduce the risk of a serious accident or injury. Eye protection, such as a face shield or goggles, may reduce the risk of foreign material getting in your eyes and help prevent loss of vision. **WARNING! Operating without eye protection can result in an accident and increases your chances of a severe injury in the event of an accident.**

[EWB02611]

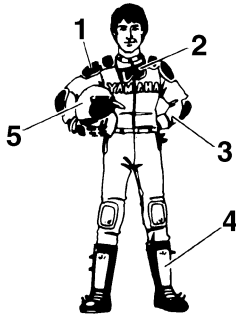

1. Protective clothing
2. Goggles
3. Gloves
4. Boots
5. Helmet

7

Do not operate after or while consuming alcohol or drugs.

The operator's performance capability is reduced by the influence of alcohol or drugs. Consuming alcohol or drugs could seriously affect your judgment, cause you to react more slowly, and affect your balance and perception. **WARNING! Never consume alcohol or drugs before or while driving this ATV. You increase your chance of an accident.** [EWB01421]



Pre-operation checks

Always inspect your ATV each time you use it to make sure the ATV is in safe operating condition. Perform the pre-operation checks listed on page 5-1. Always follow the inspection and maintenance procedures and schedules described in the Owner's Manual. **WARNING! Failure to inspect the ATV before operating it and to maintain it properly increases the possibility of an accident or equipment damage.** [EWB01431]

Speed limiter

For riders less experienced with this model, the throttle lever housing is equipped with a speed limiter. The speed limiter keeps the throttle from fully

! WARNING

Improper loading or towing can increase the risk of loss of control, an overturn, or other accident. To reduce the risk of an accident:

- **Do not exceed the maximum loading limits for the vehicle (see “MAXIMUM LOADING LIMIT” in this section or vehicle labeling).**
- **Keep weight on racks centered side to side, and as low as possible. Be sure cargo is secured – a loose load could change handling unexpectedly.**
- **Make sure the load does not interfere with your control or ability to see where you are going.**
- **Tie down cargo in the trailer securely. Make sure cargo in the trailer cannot move around. A shifting load can cause an accident.**
- **Reduce speed and allow more room to stop. A heavier vehicle takes longer to stop.**
- **Avoid hills and rough terrain. Choose terrain carefully. Use extreme caution when towing or carrying a load on inclines.**
- **Turn gradually and go slowly.**

opening, even when the throttle lever is pushed to the maximum. Turning in the adjusting screw limits the maximum engine power available and decreases the maximum speed of the ATV. Turning in the adjusting screw decreases top speed, and turning it out increases top speed. (See page 4-4.)

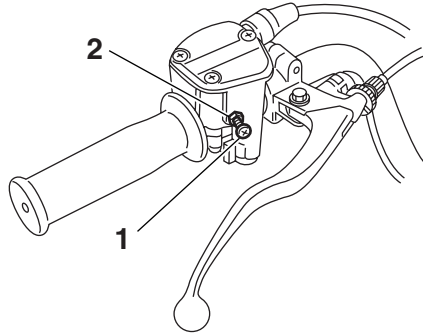

1. Adjusting screw
2. Locknut

Loading and accessories

Take extra precautions when driving with a load or trailer. Follow these instructions and always use common sense and good judgment when carrying cargo or towing a trailer.

MAXIMUM LOADING LIMIT

ATV loading limit (total weight of cargo, rider, accessories, and tongue):

105.0 kg (231 lb)

Front carrier:

5.0 kg (11 lb)

Rear carrier:

10.0 kg (22 lb)

7 Drive more slowly than you would without a load. The more weight you carry, the slower you should go. Although conditions vary, it is good practice to drive slowly (shift into first gear or low drive if available on this model) whenever you are carrying heavier loads or when towing a trailer.

During operation

Always keep your feet on the footboards during operation; otherwise, they may contact the rear wheels. **WARNING! Removing even one hand or foot can reduce your ability to control the ATV or could cause you to lose your balance and fall off of the ATV. If you remove a foot from a footboard, your foot or leg may come into contact with the rear wheels, which could injure you or cause an accident.** [EWB01471]

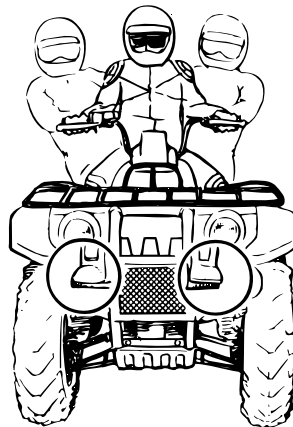

Avoid wheelies and jumping. **WARNING! Attempting wheelies, jumps, and other stunts increases the chance of an accident, including an overturn. Never attempt stunts, such as wheelies or jumps. Don't try to show off.**

[EWB01481]

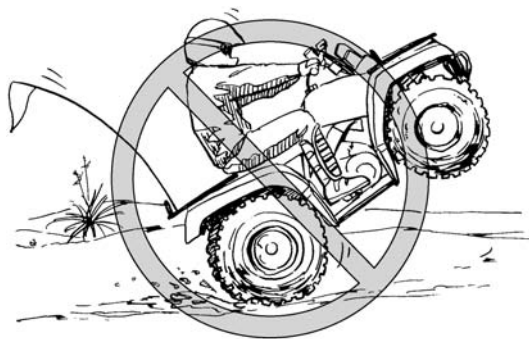

Modifications and accessories

Never modify this ATV through improper installation or use of accessories or other modification. All parts and accessories added to this ATV should be genuine Yamaha or equivalent components designed for use on this ATV and should be installed and used according to instructions. If you have questions, consult an authorized ATV dealer.

WARNING! Operating this ATV with improper modifications may cause changes in handling which in some situations could lead to an accident. [EWB01491]

Exhaust system

EWB01501

WARNING

- Dry grass or brush or other combustible material accumulated around the engine area could catch fire. Do not operate, idle, or park the ATV in dry grass or other dry ground cover. Keep the engine area free of dry grass, brush, or other combustible material.
- Someone touching the exhaust system during or after operation could be burned. Do not touch the hot exhaust system. Do not park the ATV in a place where others might be likely to touch it.

The muffler and other engine parts become extremely hot during operation and remain hot after the engine has stopped. To reduce the risk of fire during operation or after leaving the ATV, do not let brush, grass and other materials collect under the vehicle, near the muffler or exhaust pipe, or next to other hot parts. Check under the vehicle after operating in areas where combustible materials may have collected. Do not idle or park the vehicle in long dry grass or other dry ground cover.

To prevent burns, avoid touching the exhaust system. Park the ATV in a place where pedestrians or children are not likely to touch it.

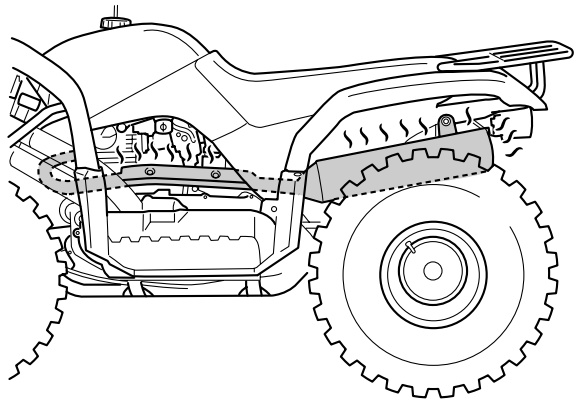

7

BE CAREFUL WHERE YOU RIDE

This ATV is designed for use on unpaved surfaces only. **WARNING! Paved surfaces may seriously affect handling and control of the ATV, and may cause the ATV to go out of control. Always avoid paved surfaces, including sidewalks, driveways, parking lots and streets.** [EWB01511]

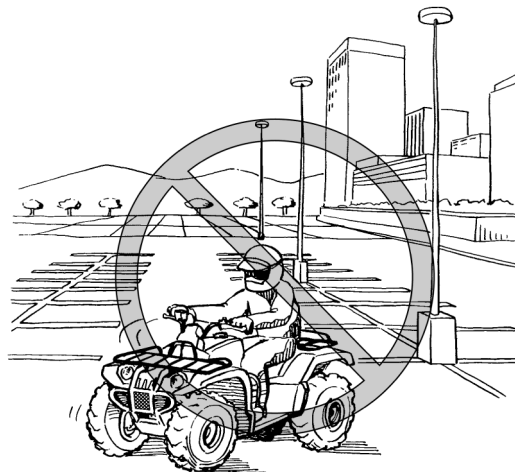

While riding on unpaved public streets or roads may be legal in your area, such operation can increase the risk of collision with other vehicles.

Watch carefully for other vehicles. Make sure you know your country's laws and regulations before you ride on unpaved public streets or roads. Do not ride on any paved public street, road or motorway. **WARNING! Never operate this ATV on any paved street, paved road or motorway. You can collide with another vehicle.** [EWB01521]



Know the terrain where you ride. Ride cautiously in unfamiliar areas. Stay alert for holes, rocks, or roots in the terrain, and other hidden hazards which may cause the ATV to upset. **WARNING! The ATV could go out of control if you do not have enough time to react to hidden rocks,**

bumps, or holes. Go slowly and be extra careful when operating on unfamiliar terrain. Always be alert to changing terrain conditions when operating the ATV. [EWB01531]

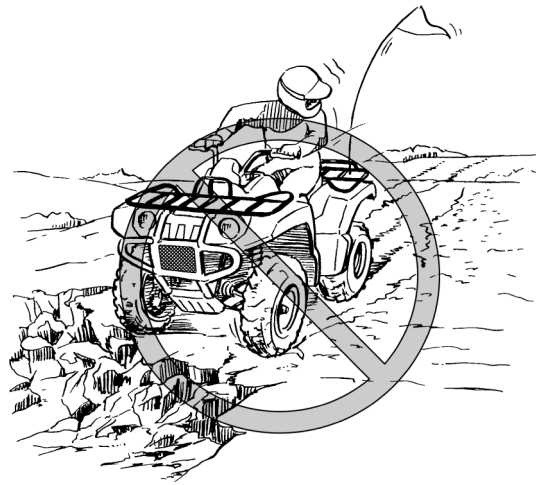

Do not operate on rough, slippery, or loose terrain until you have learned and practiced the skills necessary to control the ATV on such terrain. Always be especially cautious on these kinds of terrain. **WARNING! Failure to use extra care when operating on excessively rough, slippery, or**

loose terrain could cause loss of traction or ATV control, which could result in an accident, including an overturn. [EWB01541]



7

When riding in an area where you might not easily be seen, such as desert terrain, mount a caution flag on the ATV. **DO NOT** use the flag pole bracket as a trailer hitch. **WARNING! You could collide with another vehicle if operating in areas where you cannot easily be seen. Mount a caution flag on the ATV to make you more visible. Watch carefully for other vehicles.** [EWB01551]

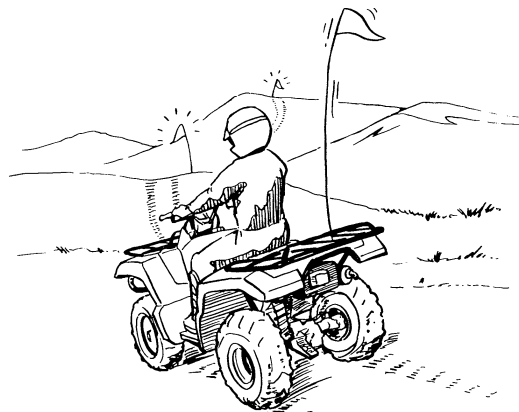

Do not ride in areas posted “no trespassing”.
Do not ride on private property without getting permission.

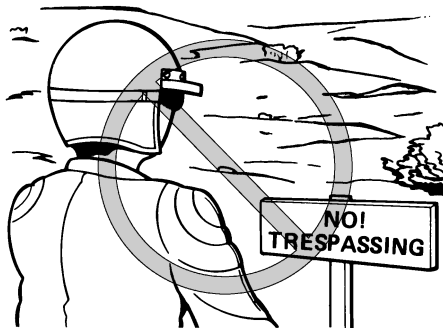

Select a large, flat, unpaved area to become familiar with your ATV. Make sure that this area is free of obstacles and other riders. You should practice control of the throttle, brakes, shifting procedures, and turning techniques in this area before trying more difficult terrain.

Set the parking brake and follow the instruction on page 6-1 to start the engine. Once it has warmed up you are ready to begin riding your ATV. With the engine idling, return the starter knob to the closed position and shift the drive select lever into the forward position, then release the parking brake. Apply the throttle slowly and smoothly.

The centrifugal clutch will engage and you will start to accelerate. If the throttle is applied too abruptly, the front wheels may lift off the ground, resulting in

a loss of directional control. Avoid higher speeds until you are thoroughly familiar with the operation of your ATV.

When slowing down or stopping, release the throttle and apply the brakes smoothly and evenly. Improper use of the brakes can cause the tires to lose traction, reducing control and increasing the possibility of an accident.

TURNING YOUR ATV

EWB01771



WARNING

Always follow proper procedures for turning as described in this Owner's Manual. Practice turning at low speeds before attempting to turn at faster speeds. Do not turn at speeds too fast for your skills or the conditions. ATV could go out of control, causing a collision or overturn.

To achieve maximum traction on unpaved surfaces, the two rear wheels turn together at the same speed. Therefore, unless the wheel on the inside of the turn is allowed to slip or lose some traction, the ATV will resist turning. A special turning technique must be used to allow the ATV to make turns quickly and easily. It is essential that this skill be learned first at low speed.

As you approach a curve, slow down and begin to turn the handlebars in the desired direction. As you do so, put your weight on the footboard to the outside of the turn (opposite your desired direction) and lean your upper body into the turn. Use the throttle to maintain an even speed through the turn. This maneuver will let the wheel on the inside of the turn slip slightly, allowing the ATV to make the turn properly.

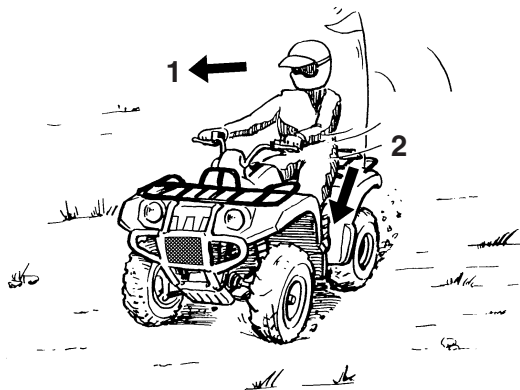

1. Lean towards inside of turn.
2. Support your weight on the outer footboard.

This procedure should be practiced at slow speed many times in a large unpaved area with no obstacles. If an incorrect technique is used, your ATV may continue to go straight. If the ATV doesn't turn, come to a stop and then practice the procedure again. If the riding surface is slippery or loose, it may help to position more of your weight over the front wheels by moving forward on the seat. Once you have learned this technique, you should be able to perform it at higher speeds or in tighter curves.

Improper riding procedures such as abrupt throttle changes, excessive braking, incorrect body movements, or too much speed for the sharpness of the turn may cause the ATV to tip. If the ATV begins to tip over to the outside while negotiating a turn, lean more to the inside. It may also be necessary to gradually let off on the throttle and steer to the outside of the turn to avoid tipping over.

Remember: Avoid higher speeds until you are thoroughly familiar with the operation of your ATV.

CLIMBING UPHILL

EWB01671

WARNING

Climbing hills improperly can cause overturns or loss of control. Use proper riding techniques described in this Owner's Manual.

- Never operate the ATV on hills too steep for the ATV or for your abilities. The ATV can overturn more easily on extremely steep hills than on level surfaces or small hills.
- Always check the terrain carefully before you start up any hill. Never climb hills with excessively slippery or loose surfaces.
- Shift your weight forward.
- Never open the throttle suddenly. The ATV could flip over backwards.
- Never go over the top of any hill at high speed. An obstacle, a sharp drop, or another vehicle or person could be on the other side of the hill.
- Never attempt to turn the ATV around on any hill until you have mastered the turning technique as described in the Owner's Manual on level ground. Be very careful when turning on any hill.

- Avoid crossing the side of a steep hill if possible. When crossing the side of a hill, shift your weight to the uphill side of the ATV.

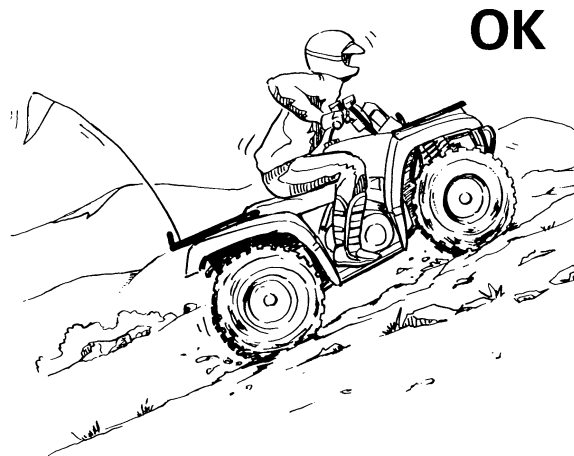

OK

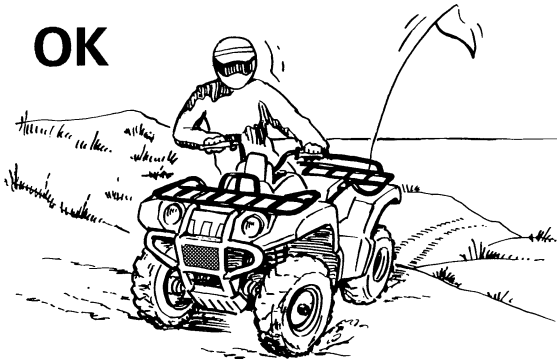

7

Do not attempt to climb hills until you have mastered basic maneuvers on flat ground. Always check the terrain carefully before attempting any hill. In all cases avoid inclines with slippery or loose surfaces, or obstacles that might cause you to lose control.

To climb a hill, you need traction, momentum, and steady throttle. Travel fast enough to maintain momentum, but not so fast that you cannot react to changes in the terrain as you climb.

It is important when climbing a hill to make sure that your weight is transferred forward on the ATV. This can be accomplished by leaning forward and,

on steeper inclines, standing on the footboards and leaning forward over the handlebars. Whenever possible, ride straight up hills.

Slow down when you reach the crest of the hill if you cannot see clearly what is on the other side – there could be another person, an obstacle, or a sharp drop-off. Use common sense and remember that some hills are too steep for you to climb or descend.

If you are climbing a hill and you find that you have not properly judged your ability to make it to the top, you should turn the ATV around while you still have forward motion (provided you have the room to do so) and go down the hill.

If your ATV has stalled or stopped and you believe you can continue up the hill, restart carefully to make sure you do not lift the front wheels which could cause you to lose control. If you are unable to continue up the hill, dismount the ATV on the uphill side. Physically turn the ATV around and then descend the hill.

If you start to roll backwards, **DO NOT** apply the rear brake, and apply the front brake gradually. The ATV could easily tip over backwards. When fully stopped, apply the rear brake as well, and then lock the parking brake. Dismount the ATV im-

mediately on the uphill side or to a side if pointed straight uphill. Turn the ATV around and remount, following the procedure described in the Owner's Manual. **WARNING! Stalling, rolling backwards or improperly dismounting while climbing a hill could result in ATV overturning. If you cannot control the ATV, dismount immediately on the uphill side.** [EWB01802]

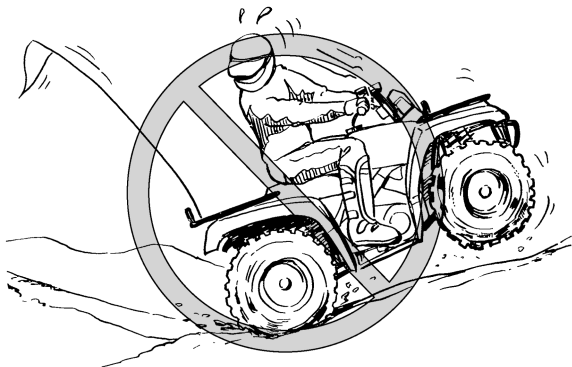

RIDING DOWNHILL

EWB01131

! WARNING

Going down a hill improperly could cause overturns or loss of control. Always follow proper procedures for going down hills as described in this Owner's Manual.

- Always check the terrain carefully before you start down any hill.
- Never operate the ATV on hills too steep for the ATV or for your abilities. The ATV can overturn more easily on extremely steep hills than on level surfaces or small hills.
- Shift your weight backward and to the up side of the hill.
- Never go down a hill at high speed.
- Avoid going down a hill at an angle that would cause the ATV to lean sharply to one side. Go straight down the hill where possible.
- Improper braking can cause the wheels on the uphill side to come off the ground or cause loss of traction. Gradually apply only the rear brake when going downhill.

When riding your ATV downhill, shift your weight as far to the rear and uphill side of the ATV as possible. Move back on the seat and sit with your arms straight. Engine compression will do most of the braking for you.

Use caution while descending a hill with loose or slippery surfaces. Braking ability and traction may be adversely affected by these surfaces. Improper braking may also cause a loss of traction. Gradually apply only the rear brake.

Whenever possible, ride your ATV straight downhill. Avoid sharp angles which could allow the ATV to tip or roll over. Carefully choose your path and ride no faster than you will be able to react to obstacles which may appear.

7

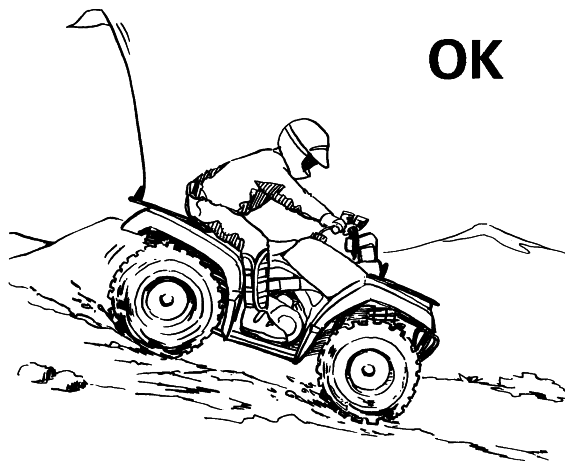

OK

CROSSING A SLOPE

EWB01632

WARNING

Improperly crossing hills or turning on hills could cause loss of control or cause the ATV to overturn.

- Always follow proper procedures as described in the Owner's Manual.
- Avoid hills with excessively slippery or loose surfaces.
- Avoid crossing the side of a steep hill.

- Shift your weight to the uphill side of the ATV.
- Never attempt to turn the ATV around on any hill until you have mastered the turning technique as described in the Owner's Manual on level ground. Be very careful when turning on any hill.

Traversing a sloping surface on your ATV requires you to properly position your weight to maintain proper balance. Be sure that you have learned the basic riding skills on flat ground before attempting to cross a sloping surface. Avoid slopes with slippery surfaces or rough terrain that may upset your balance.

As you travel across a slope, lean your body in the uphill direction. It may be necessary to correct the steering when riding on loose surfaces by pointing the front wheels slightly uphill. When riding on slopes, be sure not to make sharp turns either up or down hill.

If your ATV does begin to tip over, gradually steer in the downhill direction if there are no obstacles in your path. As you regain proper balance, gradually steer again in the direction you wish to travel.

OK



7

CROSSING THROUGH SHALLOW WATER

EWB01641



WARNING

Operating this vehicle through deep or fast-flowing water can lead to loss of control or an overturn. To reduce your risk of drowning or other injuries, use care when crossing through water. Never operate this ATV water deeper than the depth specified in your Owner's Manual, as tires may float, increasing the risk of an overturn.

The ATV can be used to cross slow moving, shallow water of up to a maximum of 20 cm (8 in) in depth. Before entering the water, choose your path carefully. Enter where there is no sharp drop off, and avoid rocks or other obstacles which may be slippery or upset the ATV. Drive slowly and carefully.

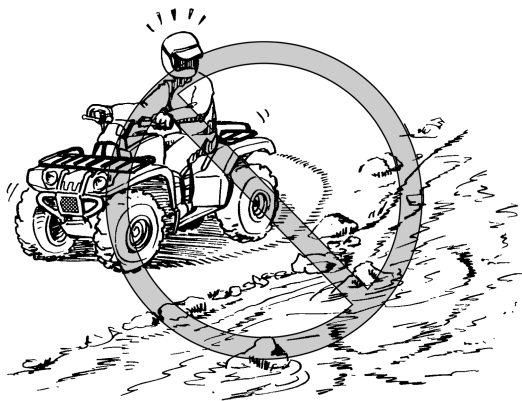

Test your brakes after leaving the water. If necessary, apply them several times to let friction dry out the linings. Do not continue to ride your ATV without verifying that you have regained proper braking

ability. **WARNING! Wet brakes may have reduced stopping ability, which could cause loss of control.** [EWB02621]

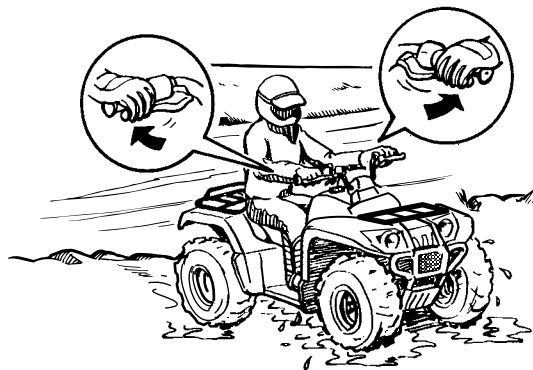

After riding your ATV in water, be sure to drain the trapped water by removing the check hose at the bottom of the air filter case. Also, remove the V-belt case drain screw to drain any water that may have accumulated. **NOTICE: Undrained water can cause damage or improper operation.** [ECB00841]
Wash the ATV in fresh water if it has been operated in salt water or muddy conditions.

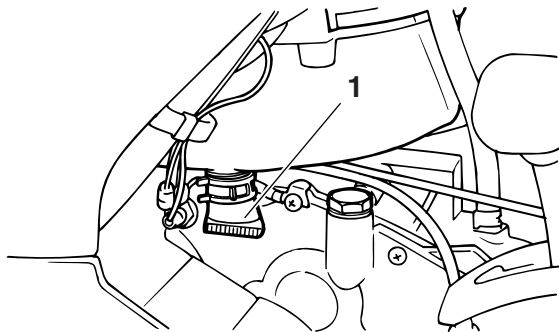

1. Air filter case check hose

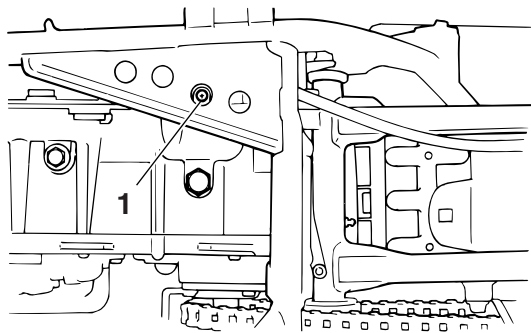

1. V-belt case drain screw

RIDING OVER ROUGH TERRAIN

EWB01651

WARNING

Riding improperly over obstacles could cause loss of control or a collision. Before operating in a new area, check for obstacles. Never attempt to ride over large obstacles, such as large rocks or fallen trees. When you go over obstacles, always follow proper procedures as described in the Owner's Manual.

Riding over rough terrain should be done with caution. Look out for obstacles which could cause damage to the ATV or could lead to an upset or accident. Be sure to keep your feet firmly mounted on the footboards at all times. Avoid jumping the ATV as loss of control and damage to the ATV may result.

7

SLIDING AND SKIDDING

EWB01662

WARNING

Skidding or sliding improperly may cause you to lose control of this ATV. You may also regain traction unexpectedly, which may cause the ATV to overturn.

- **Learn to safely control skidding or sliding by practicing at low speeds and on level, smooth terrain.**
- **On extremely slippery surfaces, such as ice, go slowly and be very cautious in order to reduce the chance of skidding or sliding out of control.**

Care should be used when riding on loose or slippery surfaces since the ATV may slide. If unexpected and uncorrected, sliding could lead to an accident.

To reduce the tendency for the front wheels to slide in loose or slippery conditions, positioning your weight over the front wheels will sometimes help.

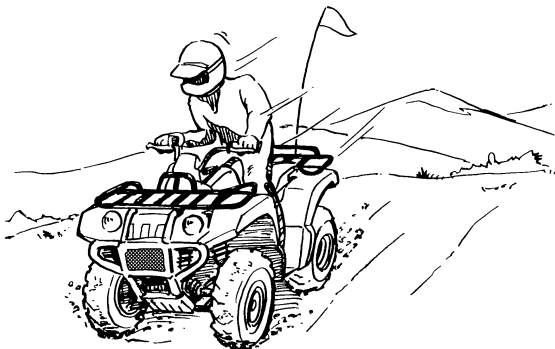

If the rear wheels of your ATV start to slide sideways, control can usually be regained (if there is room to do so) by steering in the direction of the slide. Applying the brakes or accelerating is not recommended until you have corrected the slide.

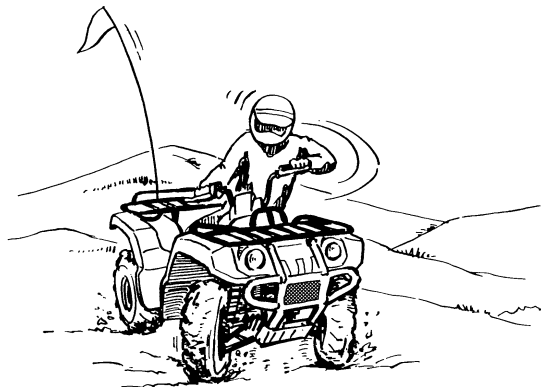

With practice, over a period of time, skill at controlled sliding can be developed. The terrain should be chosen carefully before attempting such maneuvers, since both stability and control are reduced. Bear in mind that sliding maneuvers should always be avoided on extremely slippery surfaces such as ice, since all control may be lost.

WHAT TO DO IF...

This section is designed to be a reference guide only. Be sure to read each section on riding techniques completely.

WHAT TO DO...

- If your ATV doesn't turn when you want it to:
Bring the ATV to a stop and practice the turning maneuvers again. Be sure you are putting your weight on the footboard to the outside of the turn. Position your weight over the front wheels for better control. (See page 7-12.)
- If your ATV begins to tip while turning:
Lean more into the turn to regain balance. If necessary, gradually let off the throttle and/or steer to the outside of the turn. (See page 7-12.)
- If your ATV starts to slide sideways:
Steer in the direction of the slide if you have the room. Applying the brakes or accelerating is not recommended until you have corrected the slide. (See page 7-20.)
- If your ATV can't make it up a hill you are trying to climb:
Turn the ATV around if you still have forward speed. If not, stop, dismount on the uphill side of the ATV and physically turn the ATV around. If the ATV starts to slip backwards, DO NOT USE

THE REAR BRAKE – the ATV may tip over on top of you. Dismount the ATV on the uphill side. (See page 7-14.)

- If your ATV is traversing a sloping surface:
Be sure to ride with your weight positioned towards the uphill side of the ATV to maintain proper balance. If the ATV starts to tip, steer down the hill (if there are no obstacles in your way) to regain balance. If you discover that the ATV is going to tip over, dismount on the uphill side. (See page 7-17.)
- If your ATV encounters shallow water:
Ride slowly and carefully through slow moving water, watching for obstacles. Be sure to let water drain from the ATV and CHECK YOUR BRAKES FOR PROPER OPERATION when you come out of the water. Do not continue to ride your ATV until you have regained adequate braking ability. (See page 7-18.)

PERIODIC MAINTENANCE AND ADJUSTMENT

EBU21674

Periodic inspection, adjustment, and lubrication will keep your vehicle in the safest and most efficient condition possible. Safety is an obligation of the vehicle owner/operator. The most important points of vehicle inspection, adjustment, and lubrication are explained on the following pages.

EWB01841

WARNING

Failure to properly maintain the vehicle or performing maintenance activities incorrectly may increase your risk of injury or death during service or while using the vehicle. If you are not familiar with vehicle service, have a Yamaha dealer perform the service.

EWB02562

WARNING

Turn off the engine when performing maintenance unless otherwise specified.

- **A running engine has moving parts that can catch on body parts or clothing and electrical parts that can cause shocks or fires.**

- **Running the engine while servicing can lead to eye injury, burns, fire, or carbon monoxide poisoning - possibly leading to death. See page 2-3 for more information about carbon monoxide.**

EWB02690

WARNING

Brake discs, calipers, drums, and linings can become very hot during use. To avoid possible burns, let brake components cool before touching them.

The intervals given in the periodic maintenance charts should be considered as a general guide under normal riding conditions. However, DEPENDING ON THE WEATHER, TERRAIN, GEOGRAPHICAL LOCATION, AND INDIVIDUAL USE, THE MAINTENANCE INTERVALS MAY NEED TO BE SHORTENED.

Owner's manual and tool kit

Be sure to put this owner's manual in the plastic bag and to always carry it as well as the owner's tool kit and the low-pressure tire gauge in their respective compartments under the seat.

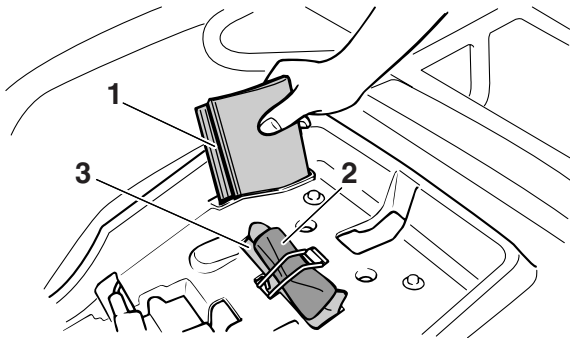

1. Owner's manual
2. Low-pressure tire gauge
3. Owner's tool kit

The service information included in this manual and the tools provided in the owner's tool kit are intended to assist you in the performance of preventive maintenance and minor repairs. However,

additional tools such as a torque wrench may be necessary to perform certain maintenance work correctly.

TIP

If you do not have the tools or experience required for a particular job, have a Yamaha dealer perform it for you.

Periodic maintenance chart for the emission control system

TIP

- For ATVs not equipped with an odometer or an hour meter, follow the month maintenance intervals.
- For ATVs equipped with an odometer or an hour meter, follow the km (mi) or hours maintenance intervals. However, keep in mind that if the ATV isn't used for a long period of time, the month maintenance intervals should be followed.
- Items marked with an asterisk should be performed by a Yamaha dealer as they require special tools, data and technical skills.

NO.	ITEM	CHECK OR MAINTENANCE JOB	Whichever comes first ⇒	INITIAL			EVERY		
				month	1	3	6	6	12
				km (mi)	320 (200)	1300 (800)	2500 (1600)	2500 (1600)	5000 (3200)
hours	20	80	160	160	320				
1	* Fuel line	• Check fuel hoses for cracks or other damage, and replace if necessary.				√	√	√	
2	Spark plug	• Check condition and clean, regap, or replace if necessary.	√	√	√	√	√	√	
3	* Valves	• Check valve clearance and adjust if necessary.	√		√	√	√	√	
4	* Carburetor	• Check starter (choke) operation and correct if necessary. • Check engine idling speed and adjust if necessary.			√	√	√	√	
5	* Crankcase breather system	• Check breather hose for cracks or other damage, and replace if necessary.				√	√	√	

NO.	ITEM	CHECK OR MAINTENANCE JOB	Whichever comes first ⇒	INITIAL			EVERY		
				month	1	3	6	6	12
				km (mi)	320 (200)	1300 (800)	2500 (1600)	2500 (1600)	5000 (3200)
				hours	20	80	160	160	320
6	*	Exhaust system	<ul style="list-style-type: none"> • Check for leakage and replace gasket(s) if necessary. • Check for looseness and tighten all screw clamps and joints if necessary. 			√	√	√	
7		Spark arrester	<ul style="list-style-type: none"> • Clean. 			√	√	√	

General maintenance and lubrication chart

TIP

- For ATVs not equipped with an odometer or an hour meter, follow the month maintenance intervals.
- For ATVs equipped with an odometer or an hour meter, follow the km (mi) or hours maintenance intervals. However, keep in mind that if the ATV isn't used for a long period of time, the month maintenance intervals should be followed.
- Items marked with an asterisk should be performed by a Yamaha dealer as they require special tools, data and technical skills.

NO.	ITEM	CHECK OR MAINTENANCE JOB	Whichever comes first ⇒	INITIAL			EVERY		
				month	1	3	6	6	12
				km (mi)	320 (200)	1300 (800)	2500 (1600)	2500 (1600)	5000 (3200)
hours	20	80	160	160	320				
1	Engine and V-belt case air filter element	<ul style="list-style-type: none"> Clean and replace if necessary. 		Every 20–40 hours (more often in wet or dusty areas)					
2	* Front brake	<ul style="list-style-type: none"> Check operation and correct if necessary. Check brake lever free play and adjust if necessary. 		√	√	√	√	√	
		<ul style="list-style-type: none"> Replace brake shoes. 		Whenever worn to the limit					
3	* Rear brake	<ul style="list-style-type: none"> Check operation and correct if necessary. Check brake lever free play and adjust if necessary. 		√	√	√	√	√	
		<ul style="list-style-type: none"> Replace brake shoes. 		Whenever worn to the limit					

NO.	ITEM	CHECK OR MAINTENANCE JOB	Whichever comes first ⇒	INITIAL			EVERY		
				month	1	3	6	6	12
				km (mi)	320 (200)	1300 (800)	2500 (1600)	2500 (1600)	5000 (3200)
hours	20	80	160	160	320				
4	*	Wheels	<ul style="list-style-type: none"> Check runout and for damage, and replace if necessary. 	√		√	√	√	
5	*	Tires	<ul style="list-style-type: none"> Check tread depth and for damage, and replace if necessary. Check air pressure and balance, and correct if necessary. 	√		√	√	√	
6	*	Wheel hub bearings	<ul style="list-style-type: none"> Check for looseness or damage, and replace if necessary. 	√		√	√	√	
7	*	Lower arm pivots	<ul style="list-style-type: none"> Lubricate with lithium-soap-based grease. 			√	√	√	
8		Drive chain	<ul style="list-style-type: none"> Check chain slack and adjust if necessary. Check rear wheel alignment and correct if necessary. Clean and lubricate. 	√	√	√	√	√	
9	*	V-belt	<ul style="list-style-type: none"> Check for wear, cracks or other damage, and replace if necessary. 	√				√	
10	*	Chassis fasteners	<ul style="list-style-type: none"> Make sure that all nuts, bolts, and screws are properly tightened. 	√	√	√	√	√	
11	*	Shock absorber assemblies	<ul style="list-style-type: none"> Check operation and correct if necessary. Check for oil leakage and replace if necessary. 			√	√	√	
12	*	Front knuckle pivots	<ul style="list-style-type: none"> Lubricate with lithium-soap-based grease. 			√	√	√	
13	*	Steering shaft	<ul style="list-style-type: none"> Lubricate with lithium-soap-based grease. 			√	√	√	

NO.	ITEM	CHECK OR MAINTENANCE JOB	Whichever comes first ⇒	INITIAL			EVERY		
				month	1	3	6	6	12
				km (mi)	320 (200)	1300 (800)	2500 (1600)	2500 (1600)	5000 (3200)
				hours	20	80	160	160	320
14	*	Steering system	<ul style="list-style-type: none"> • Check operation and repair or replace if damaged. • Check toe-in and adjust if necessary. 	√	√	√	√	√	
15		Engine oil	<ul style="list-style-type: none"> • Change. • Check ATV for oil leakage, and correct if necessary. 	√		√	√	√	
16		Engine oil strainer	<ul style="list-style-type: none"> • Clean. 	√		√		√	
17		Transmission oil	<ul style="list-style-type: none"> • Change. • Check ATV for oil leakage, and correct if necessary. 	√				√	
18	*	Moving parts and cables	<ul style="list-style-type: none"> • Lubricate. 		√	√	√	√	
19	*	Throttle lever	<ul style="list-style-type: none"> • Check operation. • Check throttle lever free play, and adjust if necessary. • Lubricate cable and lever housing. 	√	√	√	√	√	
20	*	Front and rear brake switches	<ul style="list-style-type: none"> • Check operation and correct if necessary. 	√	√	√	√	√	
21	*	Lights and switches	<ul style="list-style-type: none"> • Check operation and correct if necessary. • Adjust headlight beams. 	√	√	√	√	√	
22	*	Battery	<ul style="list-style-type: none"> • Check electrolyte level and specific gravity, and correct if necessary. • Make sure that the breather hose is properly routed. 	√	√	√	√	√	

TIP

Some maintenance items need more frequent service if you are riding in unusually wet, dusty, sandy or muddy areas, or at full-throttle.

Checking the spark plug

The spark plug is an important engine component, which is easy to check. Since heat and deposits will cause any spark plug to slowly erode, the spark plug should be removed and checked in accordance with the periodic maintenance and lubrication chart. In addition, the condition of the spark plug can reveal the condition of the engine.

To remove the spark plug

1. Remove the spark plug cap.

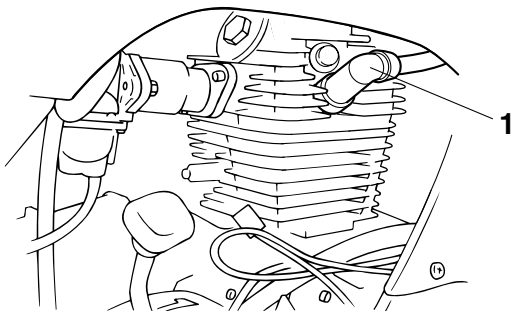

1. Spark plug cap

2. Remove the spark plug as shown, with the spark plug wrench included in the owner's tool kit.

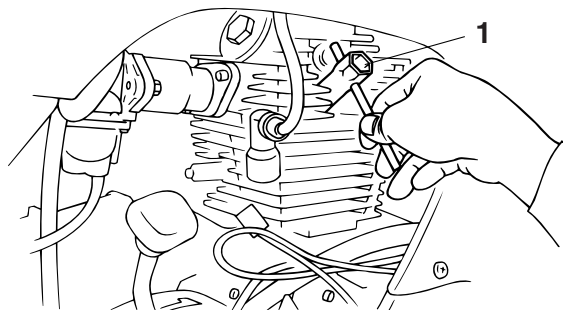

1. Spark plug wrench

To check the spark plug

1. Check that the porcelain insulator around the center electrode of the spark plug is a medium-to-light tan (the ideal color when the ATV is ridden normally).

TIP

If the spark plug shows a distinctly different color, the engine could be operating improperly. Do not attempt to diagnose such problems yourself. Instead, have a Yamaha dealer check the ATV.

2. Check the spark plug for electrode erosion and excessive carbon or other deposits, and replace it if necessary.

Specified spark plug:
NGK/CR7HSA

3. Measure the spark plug gap with a wire thickness gauge and, if necessary, adjust the gap to specification.

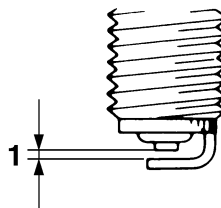

1. Spark plug gap

Spark plug gap:
0.6–0.7 mm (0.024–0.028 in)

To install the spark plug

1. Clean the surface of the spark plug gasket and its mating surface, and then wipe off any grime from the spark plug threads.
2. Install the spark plug with the spark plug wrench, and then tighten it to the specified torque.

Tightening torque:

Spark plug:

13 Nm (1.3 m·kgf, 9.4 ft·lbf)

TIP

If a torque wrench is not available when installing the spark plug, a good estimate of the correct torque is 1/4–1/2 turn past finger tight. However, the spark plug should be tightened to the specified torque as soon as possible.

3. Install the spark plug cap.

EBU23268

Engine oil

8

The engine oil level should be checked before each ride. In addition, the oil must be changed at the intervals specified in the periodic maintenance and lubrication chart.

To check the engine oil level

1. Place the ATV on a level surface.
2. Check the engine oil level on a cold engine.

TIP

If the engine was started before checking the oil level, be sure to warm up the engine sufficiently, and then wait at least ten minutes until the oil settles for an accurate reading.

3. Remove the engine oil filler cap, and then wipe the engine oil dipstick off with a clean rag.

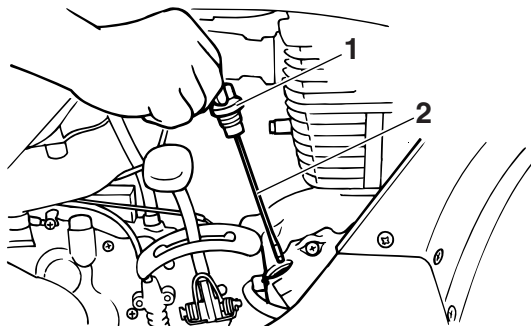

1. Engine oil filler cap
2. Engine oil dipstick

4. Insert the dipstick into the filler hole (without screwing it in), and then remove it again to check the oil level.

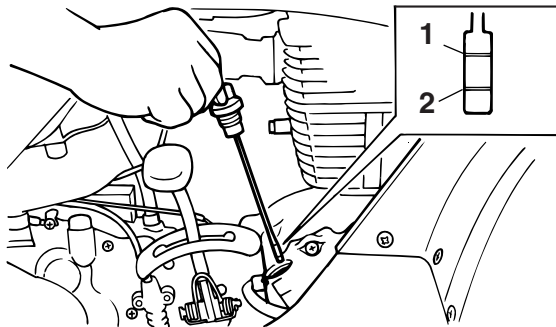

1. Maximum level mark
2. Minimum level mark

TIP

The engine oil should be between the minimum and maximum level marks.

5. If the engine oil is at or below the minimum level mark, add sufficient oil of the recommended type to raise it to the correct level. **NOTICE: Be sure the engine oil is at the correct level, otherwise engine damage may result.** [ECB00851]
6. Insert the dipstick into the oil filler hole, and then tighten the engine oil filler cap.

To change the engine oil

1. Place the ATV on a level surface.
2. Start the engine, warm it up for several minutes, and then turn it off.
3. Place an oil pan under the engine to collect the used oil.
4. Remove the engine oil filler cap, and then remove the engine oil drain bolt to drain the oil from the crankcase. **NOTICE: When removing the engine oil drain bolt, the compression spring, oil strainer and O-ring will fall out. Take care not to lose these parts.**

[ECB00311]

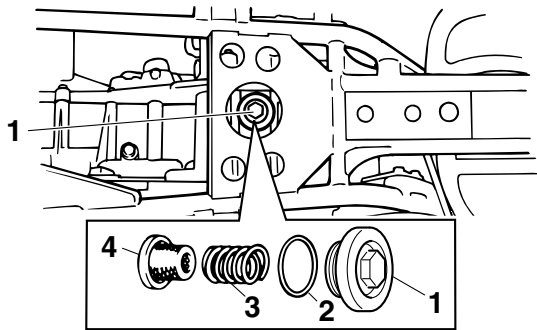

1. Engine oil drain bolt
2. O-ring
3. Spring
4. Oil strainer

8

5. Clean the oil strainer with solvent.
6. Apply a thin coat of clean engine oil to a new O-ring.
7. Install the oil strainer, the compression spring, the new O-ring and the engine oil drain bolt. Tighten the engine oil drain bolt to the specified torque. **NOTICE:** Before installing the engine oil drain bolt, be sure to install the O-ring, compression spring and oil strainer. [ECB00321]

Tightening torque:
 Engine oil drain bolt:
 32 Nm (3.2 m-kgf, 23 ft-lbf)

8. Refill with the specified amount of the recommended engine oil, and then install and tighten the engine oil filler cap.

Recommended oil:
 See page 10-1.
 Oil quantity:
 1.25 L (1.32 US qt, 1.10 Imp.qt)

TIP

Be sure to wipe off spilled oil on any parts after the engine and exhaust system have cooled down.

ECB00330

NOTICE

- Do not use oils with a diesel specification of “CD” or oils of a higher quality than specified. In addition, do not use oils labeled “ENERGY CONSERVING II” or higher.
- Make sure that no foreign material enters the crankcase.

9. Start the engine, and then let it idle for several minutes while checking it for oil leakage. If oil is leaking, immediately turn the engine off and check for the cause.
10. Turn the engine off, wait at least ten minutes, and then check the oil level and correct it if necessary.

EBU27026

Transmission oil

The transmission oil level should be checked before each ride. In addition, the transmission oil must be changed at the intervals specified in the periodic maintenance and lubrication chart.

To check the transmission oil level

1. Place the ATV on a level surface.
2. Start the engine, warm it up for several minutes, and then turn it off.
3. Wait a few minutes until the oil settles, and then loosen the transmission oil check screw located at the right side of the crankcase until oil flows out.

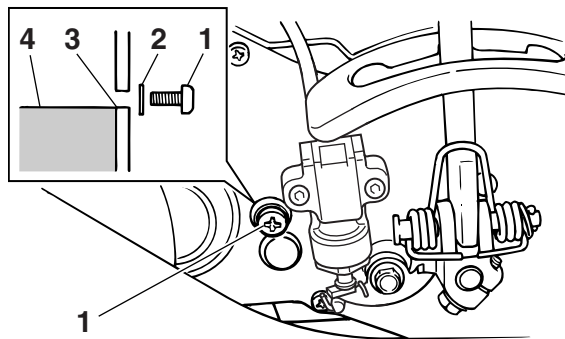

1. Transmission oil check screw
2. Gasket
3. Correct oil level
4. Transmission oil

4. If no oil flows out, remove the transmission oil filler bolt and its gasket.

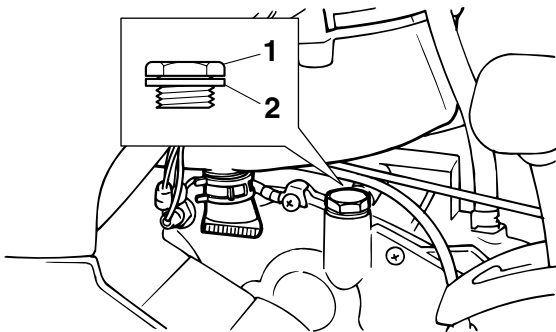

1. Transmission oil filler bolt
2. Gasket

5. Pour the recommended type of oil in the transmission oil filler hole until it flows out of the check screw hole.
6. Tighten the oil check screw to the specified torque.

Tightening torque:
Transmission oil check screw:
16 Nm (1.6 m·kgf, 12 ft·lbf)

7. Check the oil filler bolt gasket for damage, and replace it if necessary.

8. Install the transmission oil filler bolt and its gasket, and then tighten the bolt to the specified torque.

Tightening torque:
Transmission oil filler bolt:
23 Nm (2.3 m·kgf, 17 ft·lbf)

To change the transmission oil

1. Place the ATV on a level surface.
2. Start the engine, warm it up for several minutes, and then turn it off.
3. Place an oil pan under the transmission to collect the used oil.
4. Remove the transmission oil filler bolt, the transmission oil drain bolt and their gasket to drain the oil from the transmission case.

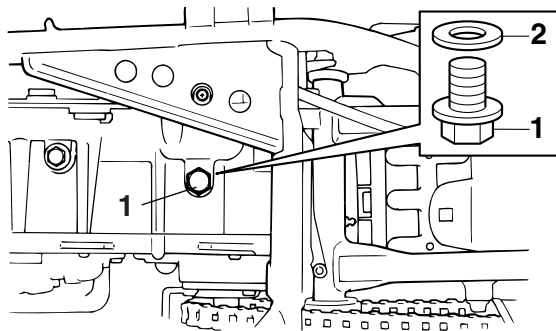

1. Transmission oil drain bolt
2. Gasket

5. Install the drain bolt and its new gasket, and then tighten the bolt to the specified torque.

Tightening torque:
Transmission oil drain bolt:
23 Nm (2.3 m·kgf, 17 ft·lbf)

6. Refill with the specified amount of the recommended transmission oil. **NOTICE: Make sure that no foreign material enters the transmission case.** [ECB00791]

Recommended transmission oil:

See page 10-1.

Oil quantity:

0.6 L (0.63 US qt, 0.53 Imp.qt)

7. Check the oil filler bolt gasket for damage, and replace it if necessary.
8. Install the oil filler bolt and its gasket, and then tighten the bolt to the specified torque.

Tightening torque:

Transmission oil filler bolt:

23 Nm (2.3 m·kgf, 17 ft·lbf)

ECB01061

NOTICE

Make sure that no oil gets on the tires or wheels.

9. Start the engine, and then let it idle for several minutes while checking the transmission for oil leakage. If oil is leaking, immediately turn off the engine and check for the cause.
10. Turn the engine off, and then check the oil level and correct it if necessary.

Cleaning the engine and V-belt case air filter elements

Both air filter elements should be cleaned at the specified intervals in the periodic maintenance chart.

Engine air filter element

TIP

There is a check hose at the bottom of the air filter case. If dust or water collects in this hose, empty the hose and clean the air filter element and air filter case.

8

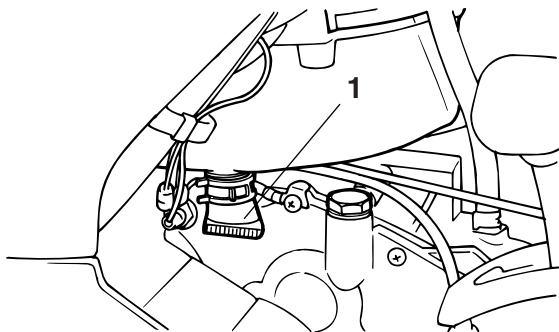

1. Air filter case check hose

1. Place the ATV on a level surface.
2. Remove the seat. (See page 4-10.)
3. Remove the breather hose by pulling it out, and then loosen the air filter joint screw.

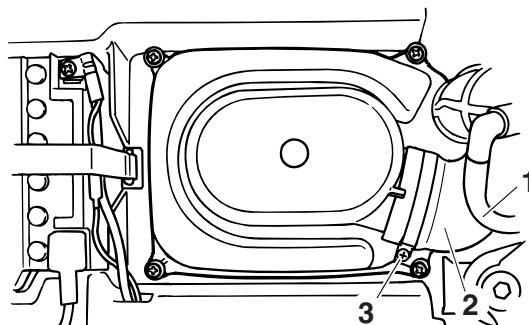

1. Breather hose
2. Air filter joint
3. Air filter joint screw
4. Remove the air filter case cover by removing its screws, then disconnecting the air filter case cover from the air filter joint.

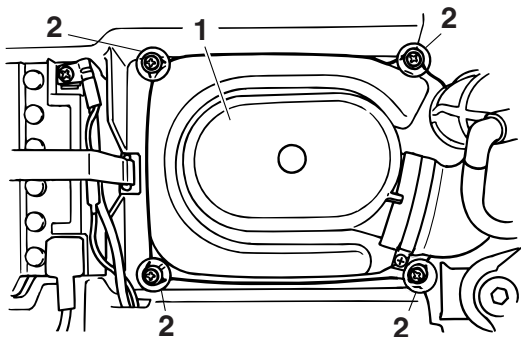

- 1. Air filter case cover
- 2. Screw

5. Remove the screw and washer shown, and then pull the sponge material off from the air filter element frame.

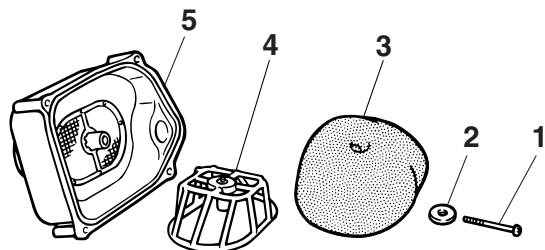

- 1. Screw
- 2. Washer
- 3. Sponge material
- 4. Air filter element frame
- 5. Air filter case cover

6. Wash the sponge material gently but thoroughly in solvent. **WARNING! Always use parts cleaning solvent to clean the sponge material. Never use low-flash-point solvents or gasoline to clean the sponge material because the engine could catch fire or explode.** [EWB01941]

7. Squeeze the excess solvent out of the sponge material and let it dry. **NOTICE: Do not twist the sponge material when squeezing it.**

[ECB00441]

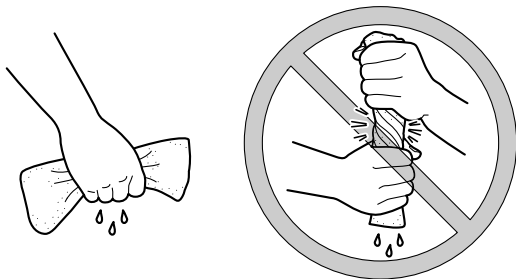

8

8. Check the sponge material and replace it if damaged.
9. Apply Yamaha foam air filter oil or other quality foam air filter oil to the sponge material.

TIP

The sponge material should be wet but not dripping.

10. Pull the sponge material over the air filter element frame.

11. Install the washer and screw. **NOTICE: Be sure to install the washer with its curved side facing outward as shown.** [ECB00453]

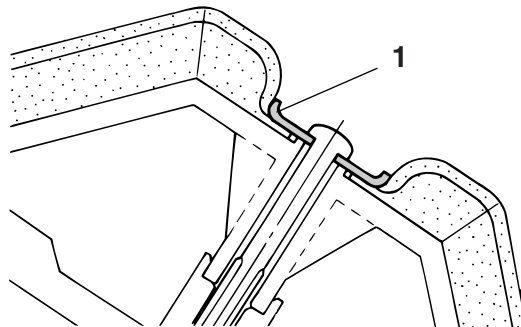

1. Washer

12. Install the air filter element into the air filter case. **NOTICE: Make sure that the air filter element is properly seated in the air filter case. Never operate the engine with the air filter element removed. This will allow unfiltered air to enter the engine, causing rapid engine wear and possible engine damage. Additionally, operation without the air filter element will affect carburetor jetting with subsequent poor performance and possible engine overheating.** [ECB00461]

13. Connect the air filter case cover to the air filter joint.
14. Install the air filter case cover by installing the screws, and then tighten the air filter joint screw.
15. Install the breather hose.
16. Install the seat.

TIP

The air filter element should be cleaned every 20–40 hours. It should be cleaned and lubricated more often if the ATV is operated in extremely dusty areas. Each time the air filter element maintenance is performed, check the air inlet of the air filter case for obstructions. Check the air filter case rubber joint to the carburetor fittings and the rubber joint manifold fittings for an air-tight seal. Tighten all fittings securely to avoid the possibility of unfiltered air entering the engine.

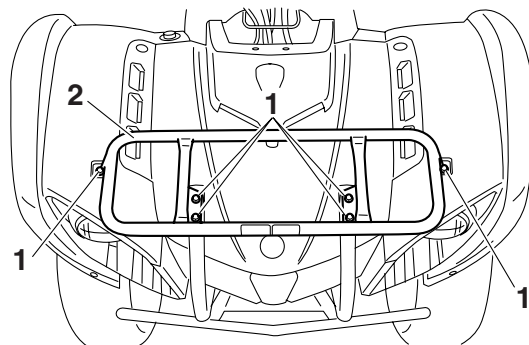

1. Front carrier bolt
2. Front carrier

3. Remove the panel by removing the quick fasteners, and then pulling it upward as shown.

V-belt case air filter element

1. Place the ATV on a level surface.
2. Remove the front carrier by removing the bolts.

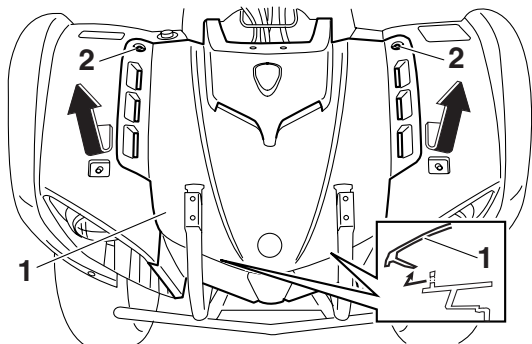

- 1. Panel
- 2. Quick fastener

4. Disconnect the coupler shown.

8

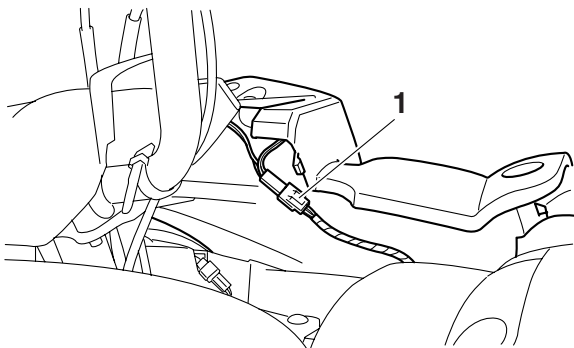

- 1. Coupler

5. Remove the air filter case cover by removing the screw.

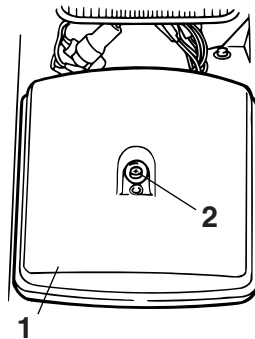

- 1. Air filter case cover
- 2. Screw

6. Remove the air filter element.

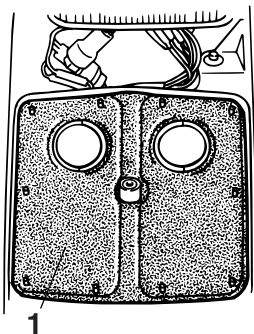

1. Air filter element

7. Tap the air filter element lightly to remove most of the dust and dirt. Blow out the remaining dirt with compressed air as shown.

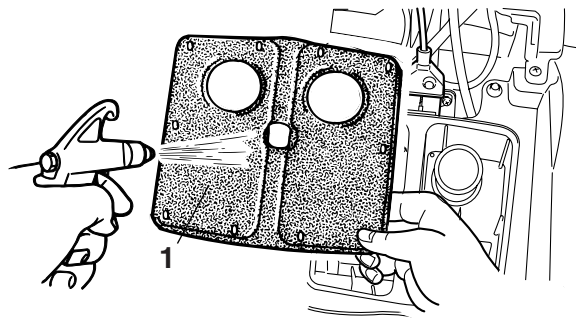

1. Air filter element

8. Check the air filter element and replace it if damaged.
9. Install the air filter element into the air filter case.
10. Install the air filter case cover by installing the screw.
11. Connect the coupler, and then install the panel by installing the quick fasteners.
12. Install the front carrier by installing the bolts, and then tighten them to the specified torque.

Tightening torque:
 Front carrier bolt:
 7 Nm (0.7 m·kgf, 5.1 ft·lbf)

Cleaning the spark arrester

Be sure the exhaust pipe and muffler are cool before cleaning the spark arrester.

1. Remove the tailpipe screws and their gasket.

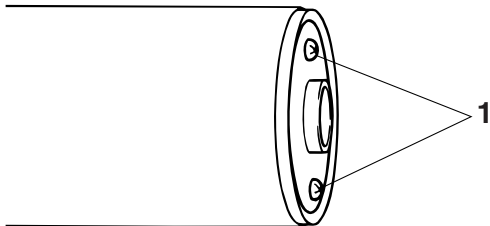

8

1. Tailpipe screw
2. Remove the tailpipe by pulling it out of the muffler.
3. Tap the tailpipe lightly, and then use a wire brush to remove any carbon deposits from the spark arrester portion of the tailpipe and inside of the tailpipe housing.

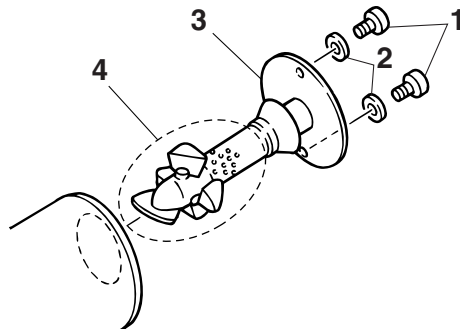

1. Tailpipe screw
2. Gasket
3. Tailpipe
4. Spark arrester

4. Insert the tailpipe into the muffler and align the screw holes.
5. Check the gaskets for damage, and replace them if necessary.
6. Install the screws and their gasket, and then tighten the screws to the specified torque.

Tightening torque:

Tailpipe screw:

7 Nm (0.7 m·kgf, 5.1 ft·lbf)

WARNING

Do not start the engine when cleaning the spark arrester, otherwise it could cause injury to the eyes, burns, carbon monoxide poisoning, possibly leading to death, and start a fire. Always let the exhaust system cool prior to touching exhaust components.

EBU30061

V-belt case drain screw

After riding in water deep enough to allow it to enter the V-belt case, remove this screw to drain the water from the case.

TIP

If water drains from the V-belt case after removing the screw, have a Yamaha dealer check the ATV as the water may affect other engine parts.

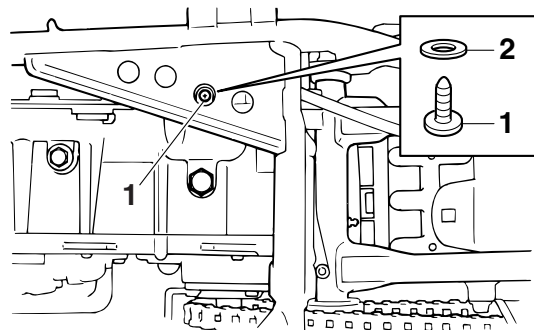

1. V-belt case drain screw
2. Gasket

To drain the water from the V-belt case

1. Place the ATV on a level surface.
2. Place a container under the V-belt case, and then remove the V-belt case drain screw and its gasket to drain the water from the V-belt case.
3. Install the V-belt case drain screw and its new gasket, and then tighten the screw to the specified torque.

Tightening torque:

V-belt case drain screw:

7 Nm (0.7 m·kgf, 5.1 ft·lbf)

EBU23940

Adjusting the carburetor

The carburetor should be checked and, if necessary, adjusted at the intervals specified in the periodic maintenance and lubrication chart. The carburetor is an important part of the engine and requires very sophisticated adjustment. Therefore, most carburetor adjustments should be left to a Yamaha dealer, who has the necessary professional knowledge and experience. The adjustment described in the following section, however, may be performed by the owner as part of routine maintenance.

ECB00480

NOTICE

The carburetor has been set and extensively tested at the Yamaha factory. Changing these settings without sufficient technical knowledge may result in poor performance or damage to the engine.

EBU24000

Adjusting the engine idling speed

The engine idling speed must be checked and, if necessary, adjusted as follows at the intervals specified in the periodic maintenance and lubrication chart.

TIP

A diagnostic tachometer is needed to make this adjustment.

1. Start the engine and warm it up.

TIP

The engine is warm when it quickly responds to the throttle.

2. Attach the tachometer to the spark plug lead.
3. Check the engine idling speed and, if necessary, adjust it to specification by turning the throttle stop screw at the carburetor. To increase the engine idling speed, turn the throttle stop screw in direction (a), and to decrease it, turn the screw in direction (b).

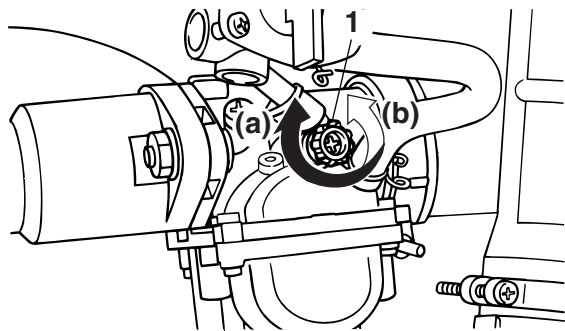

1. Throttle stop screw

Engine idling speed:
1650–1750 r/min

TIP

If the specified idling speed cannot be obtained as described above, have a Yamaha dealer make the adjustment.

EBU24047

Adjusting the throttle lever free play

The throttle lever free play should be checked and, if necessary, adjusted at the intervals specified in the periodic maintenance and lubrication chart.

The throttle lever free play should measure 1.0–3.0 mm (0.04–0.12 in) as shown. Periodically check the throttle lever free play and, if necessary, adjust it as follows.

TIP

The engine idling speed must be checked, and adjusted if necessary, before adjusting the throttle lever free play.

1. Slide the rubber cover back.
2. Loosen the locknut.
3. To increase the throttle lever free play, turn the throttle lever free play adjusting bolt in direction (a). To decrease the throttle lever free play, turn the adjusting bolt in direction (b).

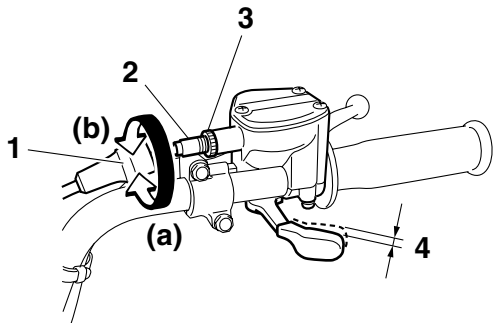

1. Rubber cover
 2. Throttle lever free play adjusting bolt
 3. Locknut
 4. Throttle lever free play
- 8**
4. Tighten the locknut.
 5. Slide the rubber cover to its original position.

EBU24060

Valve clearance

The valve clearance changes with use, resulting in improper air-fuel mixture and/or engine noise. To prevent this from occurring, the valve clearance must be adjusted by a Yamaha dealer at the intervals specified in the periodic maintenance and lubrication chart.

EBU29601

Brakes

Replacement of brake components requires professional knowledge. Brake service should be performed by a Yamaha dealer.

EWB02571



WARNING

Operating with improperly serviced or adjusted brakes could lead to a loss in braking ability and an accident.

EBU24090

Checking the front and rear brake shoes

The front and rear brake shoes must be checked for wear at the intervals specified in the periodic maintenance and lubrication chart. Each brake is provided with a wear indicator, which allows you to check the brake shoe wear without having to disassemble the brake. To check the brake shoe wear, check the position of the wear indicator while applying the brake. If a brake shoe has worn to the point that the wear indicator reaches the wear limit line or mark, have a Yamaha dealer replace the brake shoes as a set.

Front brake

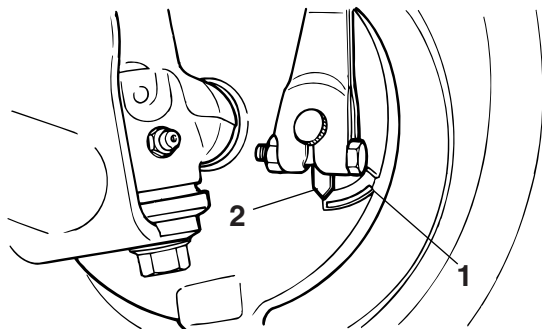

1. Wear limit line
2. Wear indicator

Rear brake

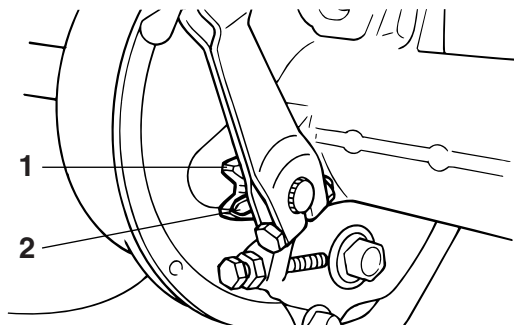

1. Wear limit line
2. Wear indicator

EBU24374

Adjusting the front brake lever free play

The brake lever free play must be checked and, if necessary, adjusted at the intervals specified in the periodic maintenance and lubrication chart.

TIP

Before adjusting the brake lever free play, check the front brake shoes for wear.

The brake lever free play should measure 5.0–8.0 mm (0.20–0.31 in) as shown. If the free play is incorrect, adjust it as follows.

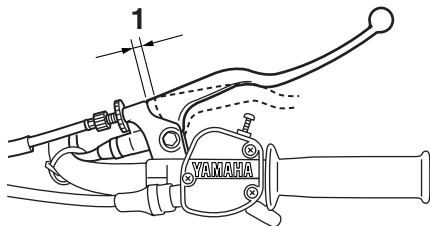

1. Brake lever free play

8

1. Remove the front carrier by removing the bolts.

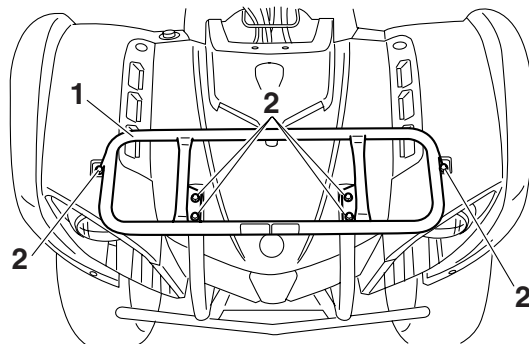

1. Front carrier
2. Front carrier bolt

2. Remove the panel by removing the quick fasteners, and then pulling it upward as shown.

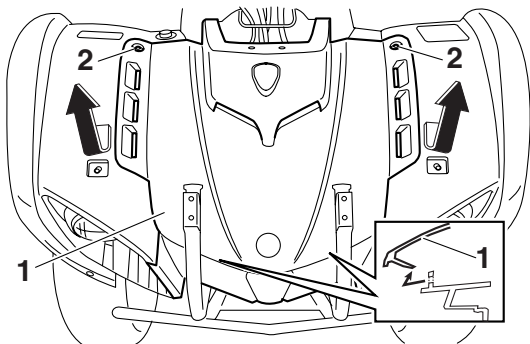

- 1. Panel
- 2. Quick fastener

3. Disconnect the coupler shown.

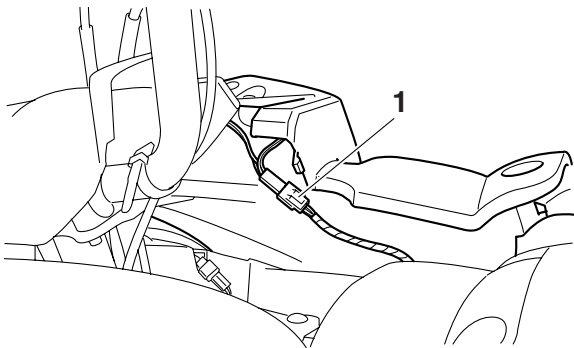

- 1. Coupler

4. Remove the V-belt air filter element cover by removing the screw.

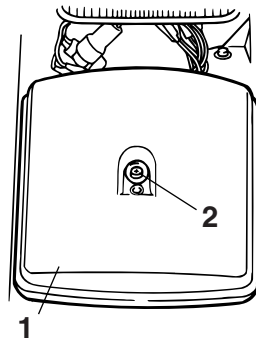

- 1. V-belt air filter element cover
- 2. Screw

5. Loosen the locknut and fully turn in the brake lever free play adjusting bolt at the brake lever.

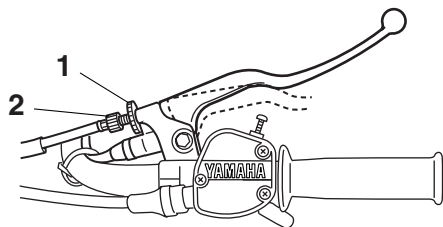

1. Locknut
2. Brake lever free play adjusting bolt

6. Make sure the brake cable joint in the equalizer is straight when the brake is applied. If the cable joint isn't straight, loosen the locknuts, and then turn the adjusting nuts on the front brake cables until the cable joint becomes straight.

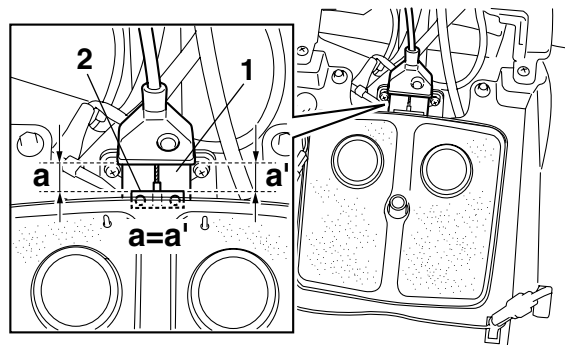

1. Brake equalizer
2. Cable joint

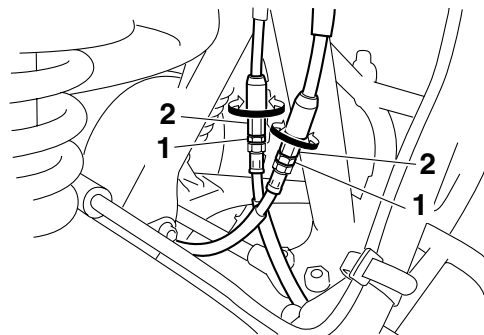

1. Locknut
2. Adjusting nut

7. Tighten the locknut on each brake cable.
8. Turn the brake lever free play adjusting bolt in direction (a) to increase the free play, and in direction (b) to decrease it.

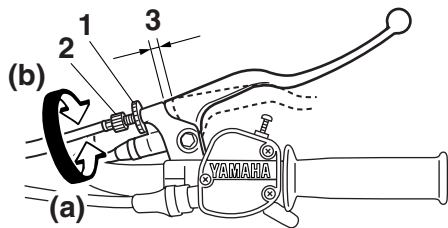

1. Locknut
 2. Brake lever free play adjusting bolt
 3. Brake lever free play
9. Tighten the locknut at the brake lever.
 10. Install the V-belt air filter element cover by installing the screw.
 11. Connect the coupler, and then install the panel by installing the quick fasteners.
 12. Install the front carrier by installing the bolts, and then tighten them to the specified torque.

Tightening torque:

Front carrier bolt:

7 Nm (0.7 m·kgf, 5.1 ft·lbf)

EBU30440

Adjusting the rear brake lever free play

The brake lever free play must be checked and, if necessary, adjusted at the intervals specified in the periodic maintenance and lubrication chart.

TIP

Before adjusting the brake lever free play, check the rear brake shoes for wear.

The brake lever free play should measure 5.0–8.0 mm (0.20–0.31 in) as shown. If the free play is incorrect, adjust it as follows.

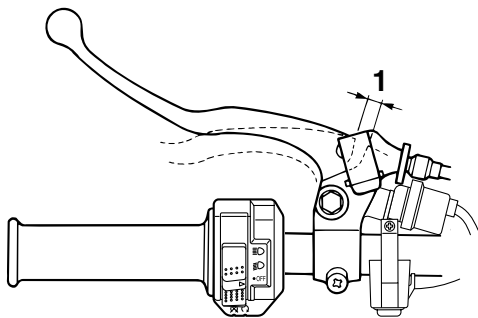

1. Brake lever free play

1. Loosen the locknut.
2. Turn the brake lever free play adjusting bolt in direction (a) to increase the free play, and in direction (b) to decrease it.

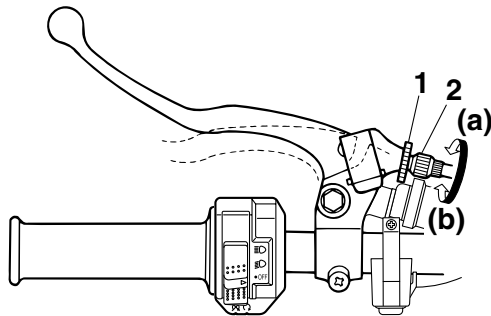

1. Locknut

2. Brake lever free play adjusting bolt

3. If the correct free play cannot be obtained as described above, turn the adjusting bolt fully in direction (a), and then adjust the free play using the brake lever free play adjusting nut on the rear wheel hub.
4. Turn the brake lever free play adjusting nut on the rear wheel hub in direction (a) to increase the free play, and in direction (b) to decrease it.

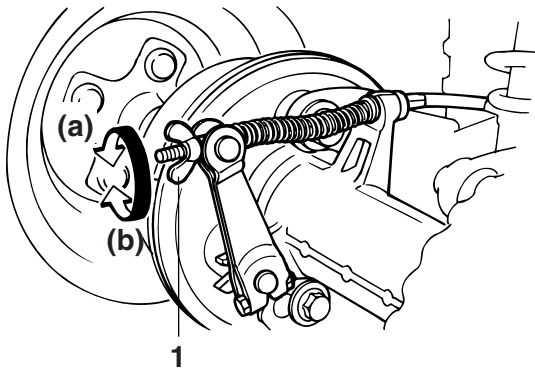

1. Brake lever free play adjusting nut

5. Use the adjusting bolt to obtain a precise adjustment if necessary, and then tighten the locknut. If the correct free play cannot be obtained, have a Yamaha dealer adjust it.

EBU24874

Drive chain slack

The drive chain slack should be checked before each ride and adjusted if necessary.

To check the drive chain slack

1. Place the ATV on a level surface.

TIP

When checking and adjusting the drive chain slack, there should be no weight on the ATV and all tires must be touching the ground.

2. Move the ATV back and forth to locate the tightest portion of the drive chain, and then measure the drive chain slack as shown.

Drive chain slack:
30.0 mm (1.18 in)

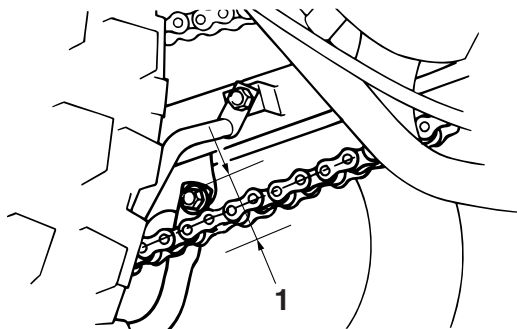

1. Drive chain slack

3. If the drive chain slack is incorrect, adjust it as follows.

To adjust the drive chain slack

1. Place the ATV on a level surface.
2. Loosen the hub stopper bolt locknut and then the hub stopper bolt.
3. Loosen the axle holding bolts.

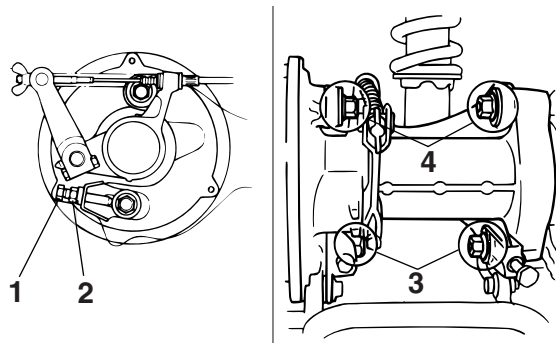

1. Hub stopper bolt
2. Hub stopper bolt locknut
3. Axle holding bolt (lower)
4. Axle holding bolt (upper)

4. Loosen the drive chain slack adjusting bolt locknut. To tighten the drive chain, turn the adjusting bolt in direction (a). To loosen the drive chain, turn the adjusting bolt in direction (b), and then push the wheels forward. **NOTICE: Improper drive chain slack will overload**

the engine as well as other vital parts of the ATV and can lead to drive chain slippage or breakage. To prevent this from occurring, keep the drive chain slack within the specified limits. [ECB00542]

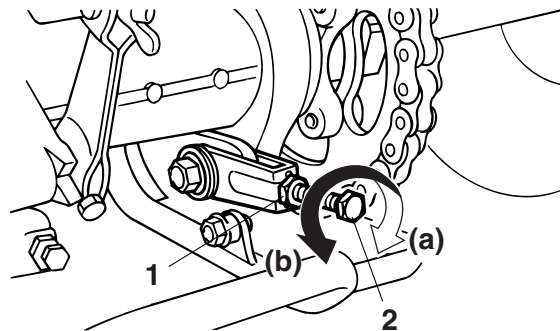

1. Locknut
2. Drive chain slack adjusting bolt

5. Tighten the drive chain slack adjusting bolt locknut and the axle holding bolts to the specified torques.

Tightening torques:

Drive chain slack adjusting bolt locknut:

16 Nm (1.6 m·kgf, 12 ft·lbf)

Axle holding bolt (upper):

85 Nm (8.5 m·kgf, 61 ft·lbf)

Axle holding bolt (lower):

60 Nm (6.0 m·kgf, 43 ft·lbf)

6. Tighten the hub stopper bolt and hub stopper bolt locknut to the specified torques.

Tightening torques:

Hub stopper bolt:

16 Nm (1.6 m·kgf, 12 ft·lbf)

Hub stopper bolt locknut:

16 Nm (1.6 m·kgf, 12 ft·lbf)

ECB00551

NOTICE

If measurement “A” of the drive chain slack adjusting bolt is less than 27 mm (1.06 in), have a Yamaha dealer replace the drive chain.

EBU24882

Lubricating the drive chain

The drive chain must be cleaned and lubricated at the intervals specified in the periodic maintenance and lubrication chart, otherwise it will quickly wear out, especially when riding in dusty or wet areas. Service the drive chain as follows.

ECB00561

NOTICE

The drive chain must be lubricated after washing the ATV or riding in the rain or wet areas.

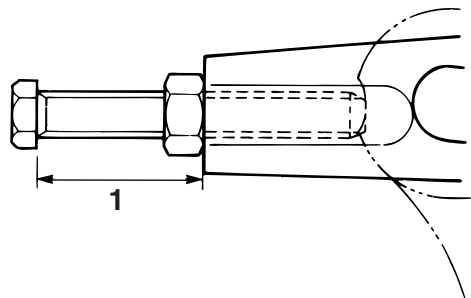

1. Measurement A

1. Clean the drive chain with kerosene and a small soft brush. **NOTICE: To prevent damaging the O-rings, do not clean the drive chain with steam cleaners, high-pressure washers or inappropriate solvents.** [ECB00571]

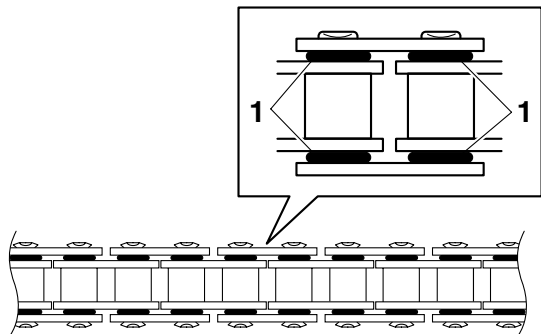

1. O-ring

2. Wipe the drive chain dry.
3. Thoroughly lubricate the drive chain with a special O-ring chain lubricant. **NOTICE: Do not use engine oil or any other lubricants for the drive chain, as they may contain substances that could damage the O-rings.** [ECB00581]

EBU24901

Checking and lubricating the cables

The operation and the condition of all control cables should be checked before each ride, and the cables and cable ends should be lubricated if nec-

essary. If a cable is damaged or does not move smoothly, have a Yamaha dealer check or replace it.

Recommended lubricant:
Engine oil

EWB02581

WARNING

- **Inspect cables frequently and replace if damaged. Corrosion can result when the cable sheaths become damaged, and cables can also become frayed or kinked, which could restrict the operation of controls and lead to an accident or injury.**
- **Always make sure all control cables work smoothly before you begin riding in cold weather. If the control cables are frozen or do not work smoothly, you could be unable to control the ATV, which could lead to an accident or collision.**

Checking and lubricating the front and rear brake levers

The operation of the front and rear brake levers should be checked before each ride, and the lever pivots should be lubricated if necessary.

Recommended lubricant:
Lithium-soap-based grease

Front brake lever

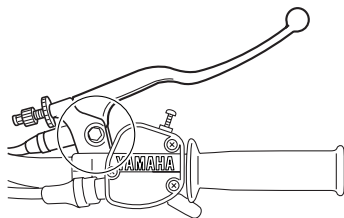

Rear brake lever

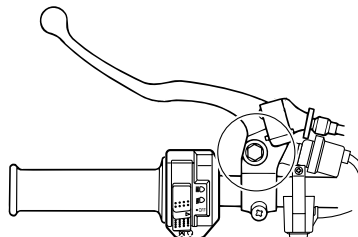

Checking the wheel hub bearings

The front and rear wheel hub bearings must be checked at the intervals specified in the periodic maintenance and lubrication chart. If there is play in a wheel hub or if a wheel does not turn smoothly, have a Yamaha dealer check the wheel hub bearings.

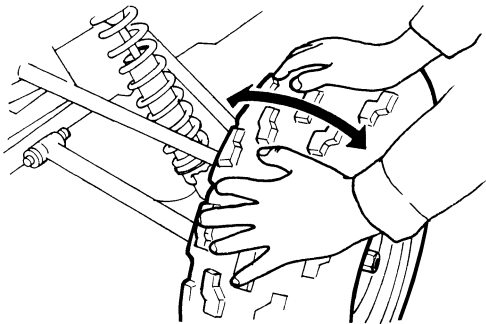

EBU30380

Lubricating the lower arm pivots

The lower arm pivots must be lubricated at the intervals specified in the periodic maintenance and lubrication chart.

8

TIP

For parts equipped with a grease nipple, use a grease gun.

Recommended lubricant:
Lithium-soap-based grease

Left side

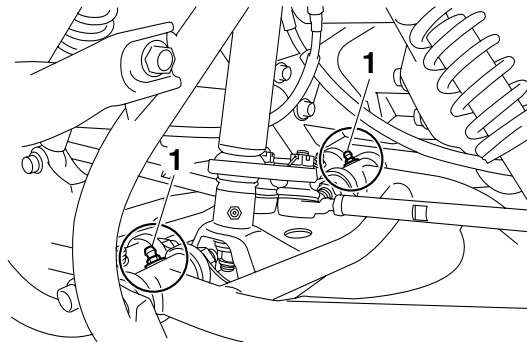

1. Grease nipple

Right side

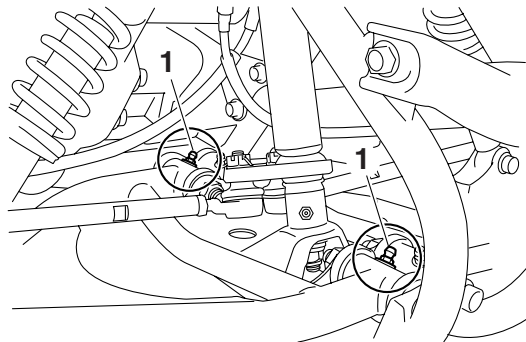

1. Grease nipple

Lubricating the front knuckle pivots

The front knuckle pivots must be lubricated at the intervals specified in the periodic maintenance and lubrication chart.

TIP

For parts equipped with a grease nipple, use a grease gun.

Recommended lubricant:
Lithium-soap-based grease

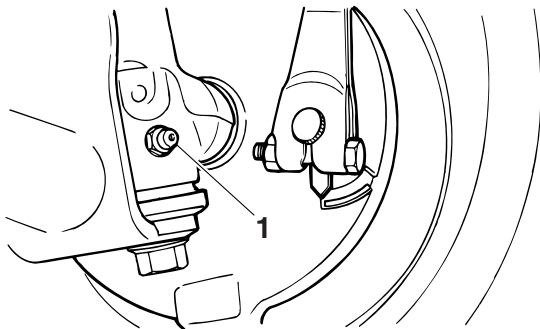

1. Grease nipple

Lubricating the steering shaft

The steering shaft must be lubricated by a Yamaha dealer at the intervals specified in the periodic maintenance and lubrication chart.

TIP

For parts equipped with a grease nipple, use a grease gun.

Recommended lubricant:
Lithium-soap-based grease

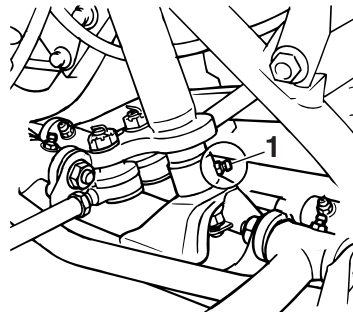

1. Grease nipple

Battery

The battery is located under the seat. (See page 4-10.)

A poorly maintained battery will corrode and discharge quickly. The electrolyte level, battery lead connections and breather hose routing should be checked before each ride and at the intervals specified in the periodic maintenance and lubrication chart.

EWP02160

⚠ WARNING

Battery electrolyte is poisonous and dangerous, as it contains sulfuric acid, which can cause severe burns. Avoid contact with skin, eyes or clothing. Always shield your eyes when working near batteries.

Antidote:

EXTERNAL: Flush with water.

INTERNAL: Drink large quantities of water or milk. Follow with milk of magnesia, beaten egg or vegetable oil. Call a physician immediately.

EYES: Flush with water for 15 minutes and get prompt medical attention.

Batteries produce explosive gases. Keep sparks, flame, cigarettes or other sources of ignition away. Ventilate when charging or using in an enclosed space.

KEEP OUT OF REACH OF CHILDREN.

To check the electrolyte level

1. Place the ATV on a level surface.
2. Check the electrolyte level in the battery.

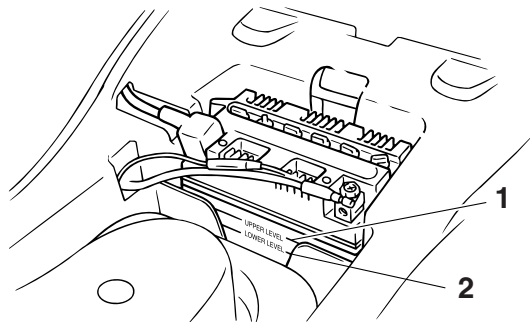

1. Maximum level mark
2. Minimum level mark

TIP

The electrolyte should be between the minimum and maximum level marks.

- If the electrolyte is at or below the minimum level mark, add distilled water to raise it to the maximum level mark. **NOTICE: Use only distilled water, as tap water contains minerals that are harmful to the battery.** [ECB00591]
- Check and, if necessary, tighten the battery lead connections and correct the breather hose routing.

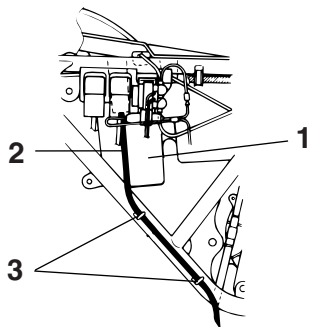

- Battery
- Battery breather hose
- Guide

To remove the battery

- Disconnect the negative lead first and then the positive lead. **NOTICE: When removing the battery, the main switch must be off, and the negative lead must be disconnected before the positive lead.** [ECB01001]

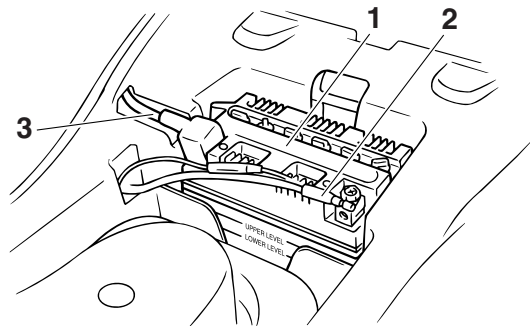

- Battery
 - Negative battery lead (black)
 - Positive battery lead (red)
- Remove the battery.

To store the battery

- If the ATV will not be used for more than one month, remove the battery, fully charge it, and then place it in a cool, dry place.

- If the battery will be stored for more than two months, check the specific gravity of the electrolyte at least once a month and fully charge the battery whenever necessary.

ECB01100

NOTICE

- **Always keep the battery charged. Storing a discharged battery can cause permanent battery damage.**
- **Do not leave or store the battery on its side.**

To install the battery

TIP

Be sure the battery is fully charged.

8

1. Install the battery.
2. Connect the positive lead first, and then connect the negative lead. **NOTICE: When installing the battery, the main switch must be off, and the positive lead must be connected before the negative lead.** [ECB01110]

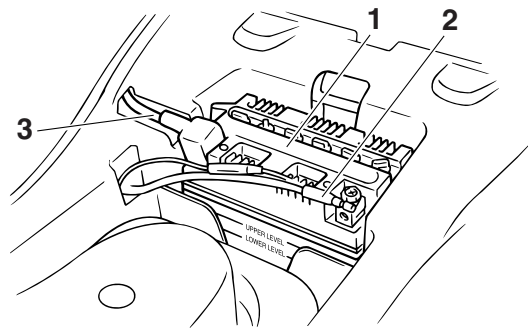

1. Battery
 2. Negative battery lead (black)
 3. Positive battery lead (red)
3. Make sure that the breather hose is properly routed, in good condition, and not obstructed. **NOTICE: If the breather hose is positioned in such a way that the frame is exposed to electrolyte or gas expelled from the battery, the frame could suffer structural and external damages.** [ECB00611]

Replacing the fuse

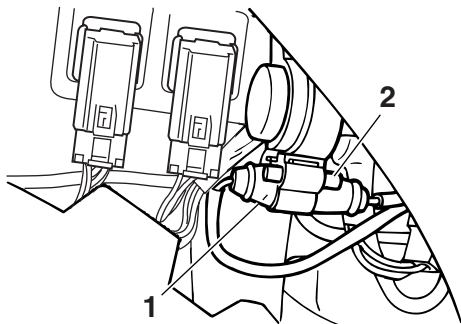

1. Fuse
2. Spare fuse

The fuse holder is located on the right side of the ATV.

If the fuse is blown, replace it as follows.

1. Turn the key to "OFF" and turn off all electrical circuits.

NOTICE

To prevent accidental short-circuiting, turn off the main switch when checking or replacing a fuse.

2. Remove the blown fuse, and then install a new fuse of the specified amperage. **WARNING! Always use a fuse of the specified rating, and never use a substitute object in place of the proper fuse. An improper fuse or a substitute object can cause damage to the electrical system, which could lead to a fire.** [EWB02172]

Specified fuse:
15.0 A

8

3. Turn the key to "ON" and turn on the electrical circuits to check if the devices operate.
4. If the fuse immediately blows again, have a Yamaha dealer check the electrical system.

Replacing a headlight bulb

If a headlight bulb burns out, replace it as follows.

1. Remove the cover at the rear of the headlight by pulling it off.

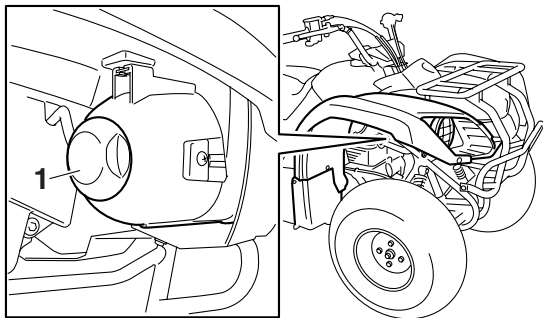

1. Cover at the rear of the headlight

8

2. Remove the headlight bulb holder cover by pulling it off.

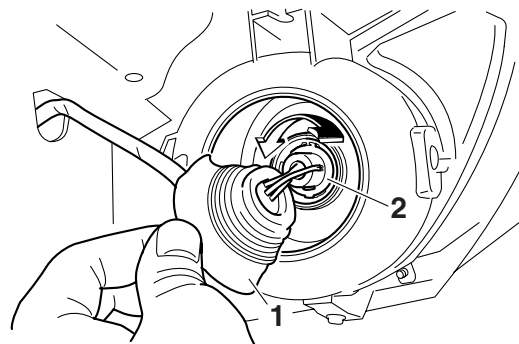

1. Headlight bulb holder cover
2. Headlight bulb holder

3. Remove the headlight bulb holder by pushing it in and turning it counterclockwise.
4. Remove the burnt-out bulb by pulling it out.
5. Insert a new headlight bulb into the bulb holder by pushing it in. **NOTICE: Do not touch the glass part of the headlight bulb to keep it free from oil, otherwise the transparency of the glass, the luminosity of the bulb, and the bulb life will be adversely affected. Thoroughly clean off any dirt and fingerprints on the headlight bulb using a cloth moistened with alcohol or thinner.** [ECB00651]

Adjusting a headlight beam

NOTICE

It is advisable to have a Yamaha dealer make this adjustment.

To raise a headlight beam, turn the headlight beam adjusting screw in direction (a).

To lower a headlight beam, turn the adjusting screw in direction (b).

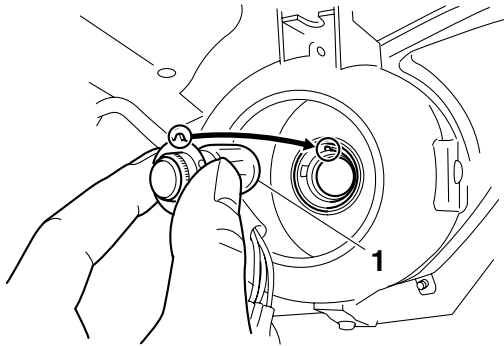

1. Headlight bulb

6. Install the bulb holder by pushing it in and turning it clockwise.
7. Install the bulb holder cover and the cover at the rear of the headlight. **NOTICE: Make sure the headlight bulb holder cover is securely fitted over the bulb holder and seated properly.** [ECB00671]
8. Adjust the headlight beam if necessary.

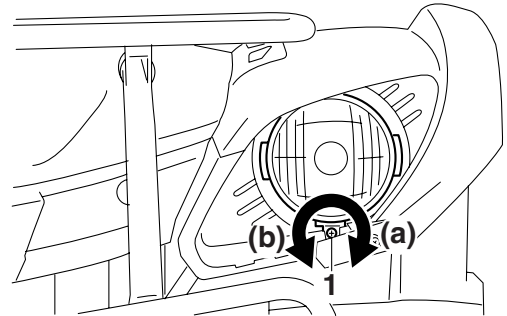

1. Headlight beam adjusting screw

Replacing the tail/brake light bulb

If the tail/brake light bulb burns out, replace it as follows.

1. Remove the tail/brake light bulb holder (together with the bulb) by turning it counterclockwise.

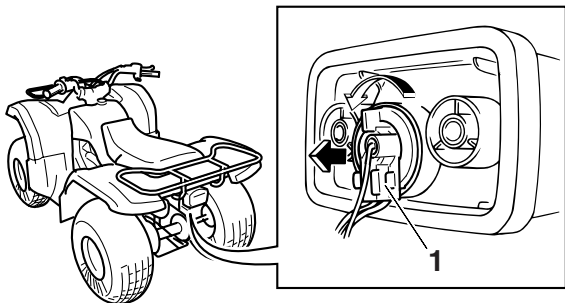

1. Tail/brake light bulb holder
2. Remove the burnt-out bulb by pushing it in and turning it counterclockwise.
3. Insert a new bulb into the bulb holder, push it in, and then turn it clockwise until it stops.

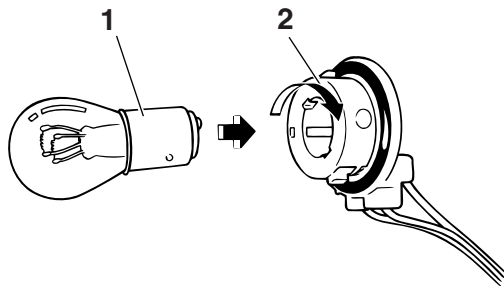

1. Tail/brake light bulb
2. Tail/brake light bulb holder
4. Install the bulb holder (together with the bulb) by turning it clockwise.

Removing a wheel

1. Place the ATV on a level surface.
2. Loosen the wheel nuts.

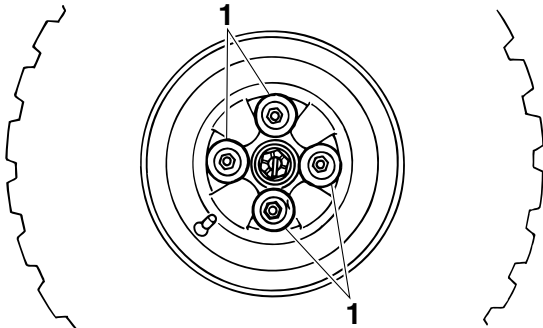

1. Wheel nut

3. Elevate the ATV and place a suitable stand under the frame.
4. Remove the nuts from the wheel.
5. Remove the wheel.

EBU25692

Installing a wheel

1. Place the ATV on a level surface.
2. Elevate the ATV and place a suitable stand under the frame.
3. Install the wheel and the nuts.

TIP

Tapered nuts are used for both the front and rear wheels. Install the nuts with their tapered side towards the wheel.

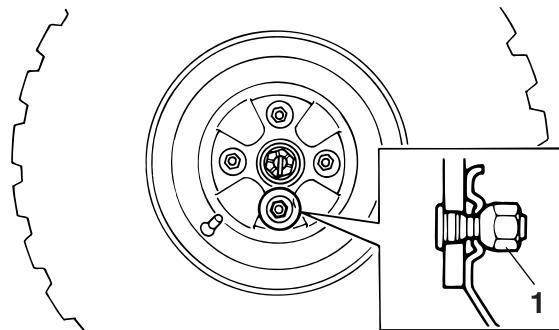

1. Tapered nut

4. Lower the ATV to the ground.
5. Tighten the wheel nuts to the specified torques.

Tightening torques:

Front wheel nut:

55 Nm (5.5 m·kgf, 40 ft·lbf)

Rear wheel nut:

55 Nm (5.5 m·kgf, 40 ft·lbf)

EWB02280



Do not smoke when checking the fuel system. Fuel can ignite or explode, causing severe injury or property damage. Make sure there are no open flames or sparks in the area, including pilot lights from water heaters or furnaces.

EBU25720

Troubleshooting

Although Yamaha ATVs receive a thorough inspection before shipment from the factory, trouble may occur during operation. Any problem in the fuel, compression, or ignition systems, for example, can cause poor starting and loss of power.

The following troubleshooting chart represents a quick and easy procedure for checking these vital systems yourself. However, should your ATV require any repair, take it to a Yamaha dealer, whose skilled technicians have the necessary tools, experience, and know-how to service the ATV properly. Use only genuine Yamaha replacement parts. Imitation parts may look like Yamaha parts, but they are often inferior, have a shorter service life and can lead to expensive repair bills.

Troubleshooting chart

1. Fuel

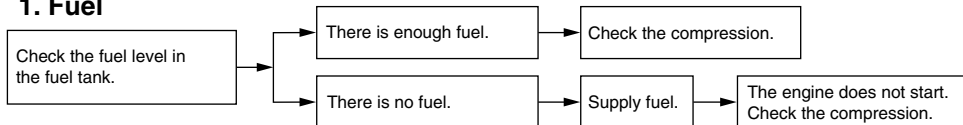

2. Compression

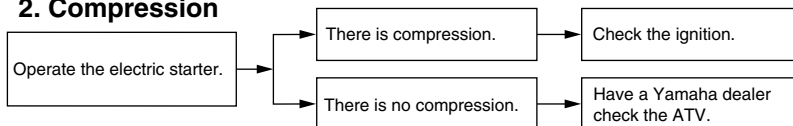

3. Ignition

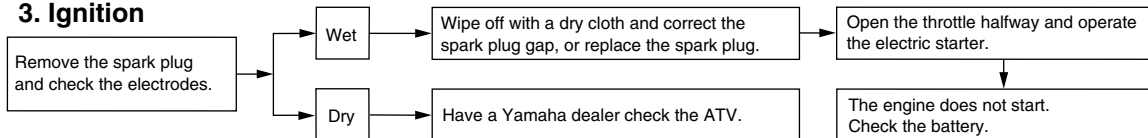

4. Battery

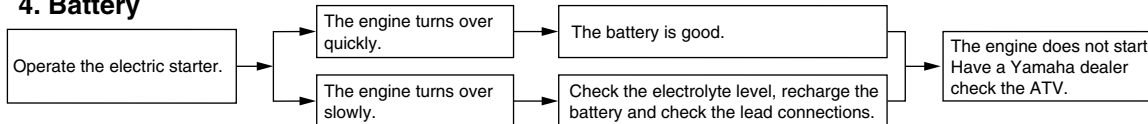

CLEANING AND STORAGE

EBU25902

Cleaning

Frequent, thorough cleaning of your ATV will not only enhance its appearance but will improve its general performance and extend the useful life of many components.

1. Before cleaning the ATV:
 - a. Block off the end of the exhaust pipe to prevent water entry. A plastic bag and strong rubber band may be used.
 - b. Make sure the spark plug and all filler caps are properly installed.
2. If the engine case is excessively greasy, apply degreaser with a paint brush. Do not apply degreaser to the chain, sprockets or wheel axles.
3. Rinse the dirt and degreaser off with a garden hose. Use only enough pressure to do the job. **WARNING! Wet brakes may have reduced stopping ability, increasing the chance of an accident. Test the brakes after washing. Apply the brakes several times at slow speeds to let friction dry out the linings.**

[EWB02311] **NOTICE: Excessive water pressure**

may cause water seepage and deterioration of wheel bearings, brakes, transmission seals and electrical devices. Many expensive repair bills have resulted from improper high-pressure detergent applications such as those available in coin-operated car washers. [ECB00711]

4. Once most of the dirt has been hosed off, wash all surfaces with warm water and mild, detergent-type soap. An old toothbrush or bottle brush is handy for hard-to-reach places.
5. Rinse the ATV off immediately with clean water and dry all surfaces with a chamois, clean towel or soft absorbing cloth.
6. Dry the chain and lubricate it to prevent it from rusting.
7. Clean the seat with a vinyl upholstery cleaner to keep the cover pliable and glossy.
8. Automotive type wax may be applied to all painted and chrome plated surfaces. Avoid combination cleaner-waxes. Many contain abrasives which may mar the paint or protective finish. When finished cleaning, start the engine and let it idle for several minutes.

Storage

Short-term

Always store your ATV in a cool, dry place and, if necessary, protect it against dust with a porous cover. **NOTICE: Storing the ATV in a poorly ventilated room or covering it with a tarp while it is still wet, will allow water and humidity to seep in and cause rust. To prevent corrosion, avoid damp cellars, stables (because of the presence of ammonia) and areas where strong chemicals are stored.** [ECB00721]

Long-term

Before storing your ATV for several months:

1. Follow all the instructions in the “Cleaning” section of this chapter.
2. Turn the fuel cock lever to “OFF”.
3. Drain the carburetor float chamber by loosening the drain bolt; this will prevent fuel deposits from building up. Pour the drained fuel into the fuel tank.
4. Fill up the fuel tank and add fuel stabilizer (if available) to prevent the fuel from deteriorating.

Specified amount:

7.5 ml of stabilizer to each liter of fuel (or 1 oz of stabilizer to each gallon of fuel)

5. Perform the following steps to protect the cylinder, piston rings, etc. from corrosion.
 - a. Remove the spark plug cap and spark plug.
 - b. Pour a teaspoonful of engine oil into the spark plug bore.
 - c. Install the spark plug cap onto the spark plug, and then place the spark plug on the cylinder head so that the electrodes are grounded. (This will limit sparking during the next step.)
 - d. Turn the engine over several times with the starter. (This will coat the cylinder wall with oil.)
 - e. Remove the spark plug cap from the spark plug, and then install the spark plug and the spark plug cap.
6. Lubricate all control cables and the pivoting points of all levers.
7. Check and, if necessary, correct the tire air pressure, and then block up the ATV so that all of its wheels are off the ground. Alternative-

ly, turn the wheels a little every month in order to prevent the tires from becoming degraded in one spot.

8. Cover the muffler outlet with a plastic bag to prevent moisture from entering it.
9. Remove the battery and fully charge it. Store it in a cool, dry place and charge it once a month. Do not store the battery in an excessively cold or warm place [less than 0 °C (30 °F) or more than 30 °C (90 °F)]. For more information on storing the battery, see page 8-41.

TIP _____
Make any necessary repairs before storing the ATV.

SPECIFICATIONS

Dimensions:

- Overall length:
1700 mm (66.9 in)
- Overall width:
990 mm (39.0 in)
- Overall height:
980 mm (38.6 in)
- Seat height:
685 mm (27.0 in)
- Wheelbase:
1080 mm (42.5 in)
- Ground clearance:
145 mm (5.7 in)
- Minimum turning radius:
2900 mm (114 in)

Weight:

- With oil and fuel:
152.0 kg (335 lb)

Noise and vibration level:

- Noise level (77/311/EEC):
78.0 dB(A) @ 3500 r/min
- Vibration on seat (EN1032, ISO5008):
Will not exceed 0.5 m/s²
- Vibration on handlebar (EN1032, ISO5008):
Will not exceed 2.5 m/s²

Engine:

- Engine type:
Air cooled 4-stroke, SOHC

Cylinder arrangement:

Forward-inclined single cylinder

Displacement:

124 cm³

Bore × stroke:

49.0 × 66.0 mm (1.93 × 2.60 in)

Compression ratio:

9.00 : 1

Starting system:

Electric starter

Lubrication system:

Wet sump

Engine oil:

Recommended brand:

YAMALUBE

Type:

SAE 5W-30, 10W-30, 10W-40, 15W-40, 20W-40 or 20W-50

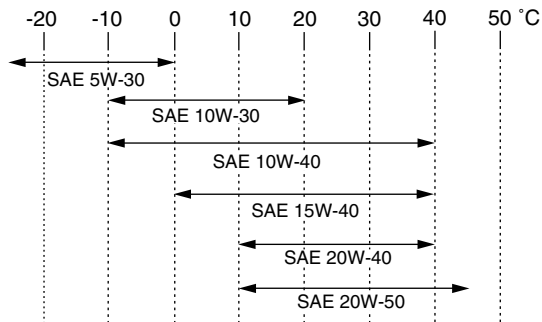

Recommended engine oil grade:

API service SG type or higher, JASO standard MA

Engine oil quantity:

Periodic oil change:

1.25 L (1.32 US qt, 1.10 Imp.qt)

10

Transmission oil:

Quantity:

0.6 L (0.63 US qt, 0.53 Imp.qt)

Air filter:

Air filter element:

Wet element

Fuel:

Recommended fuel:

Regular unleaded gasoline only

Fuel tank capacity:

7.0 L (1.85 US gal, 1.54 Imp.gal)

Fuel reserve amount:

1.3 L (0.34 US gal, 0.29 Imp.gal)

Carburetor:

Type × quantity:

VM18SH x 1

Spark plug (s):

Manufacturer/model:

NGK/CR7HSA

Spark plug gap:

0.6–0.7 mm (0.024–0.028 in)

Clutch:

Clutch type:

Dry, centrifugal automatic

Transmission:

Primary reduction system:

Helical gear/spur gear

Primary reduction ratio:

$43/14 \times 40/17$ (7.226)

Secondary reduction system:

Chain drive

Secondary reduction ratio:

$32/12$ (2.666)

Transmission type:

V-belt automatic

Operation:

Centrifugal automatic type

Reverse gear:

49/14 × 49/15 × 40/17 (26.902)

Chassis:

Frame type:

Steel tube frame

Caster angle:

6.0 °

Trail:

15.0 mm (0.59 in)

Front tire:

Type:

Tubeless

Size:

AT20 x 7-8

Manufacturer/model:

DUNLOP/KT536A

Rear tire:

Type:

Tubeless

Size:

AT22 x 10-8

Manufacturer/model:

DUNLOP/KT537A

Loading:

Maximum loading limit:

105.0 kg (231 lb)

(Total weight of rider, cargo, accessories, and tongue)

Tire air pressure (measured on cold tires):

Recommended:

Front:

20.0 kPa (0.200 kgf/cm², 2.9 psi)

Rear:

25.0 kPa (0.250 kgf/cm², 3.6 psi)

Minimum:

Front:

17.0 kPa (0.170 kgf/cm², 2.5 psi)

Rear:

22.0 kPa (0.220 kgf/cm², 3.2 psi)

Front wheel:

Wheel type:

Panel wheel

Rim size:

8 x 5.5AT

Rear wheel:

Wheel type:

Panel wheel

Rim size:

8 x 8.0AT

Front brake:

Type:

Drum brake

Operation:

Right hand operation

Rear brake:

Type:

Drum brake

Operation:

Left hand operation

Front suspension:

Type:

Swing axle

Spring/shock absorber type:

Coil spring/oil damper

Wheel travel:

70 mm (2.8 in)

Rear suspension:

Type:

Swingarm

Spring/shock absorber type:

Coil spring/oil damper

Wheel travel:

80 mm (3.1 in)

Electrical system:

Ignition system:

DC CDI

Charging system:

AC magneto

Battery:

Model:

12N12C-4A-2

Voltage, capacity:

12 V, 12.0 Ah

Headlight:

Bulb type:

Krypton bulb

Bulb voltage, wattage × quantity:

Headlight:

12 V, 30.0/30.0 W × 2

Tail/brake light:

12 V, 5.0/21.0 W × 1

Neutral indicator light:

12 V, 1.7 W × 1

Reverse indicator light:

12 V, 1.7 W × 1

Fuses:

Main fuse:

15.0 A

EBU30400

For EUR only

The figures quoted are emission levels and are not necessarily safe working levels. Whilst there is a correlation between the emission and exposure levels, this cannot be used reliably to determine whether or not further precautions are required. Factors that influence the actual level of exposure of work-force include the characteristics of the work room, the other sources of noise, etc. i.e. the number of machines and other adjacent processes, and the length of time for which an operator is exposed to the noise. Also the permissible exposure level can vary from country. This information, however, will enable the user of the machine to make a better evaluation of the hazard and risk.

CONSUMER INFORMATION

EBU28201

Identification numbers

Record the vehicle identification number and model label information in the spaces provided below for assistance when ordering spare parts from a Yamaha dealer or for reference in case the ATV is stolen.

VEHICLE IDENTIFICATION NUMBER:

MODEL LABEL INFORMATION:

EBU26041

Vehicle identification number

The vehicle identification number is stamped into the frame.

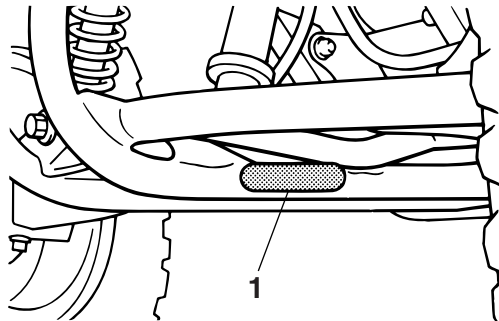

1. Vehicle identification number

The year of manufacture is listed in the vehicle identification number as shown in the illustration.

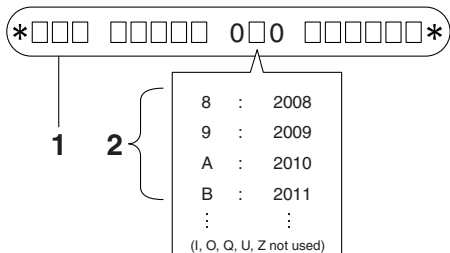

1. Vehicle identification number
2. Year of manufacture

TIP _____
 The vehicle identification number is used to identify your ATV.

EBU26050

Model label

The model label is affixed at the location in the illustration. Record the information on this label in the space provided. This information will be needed when ordering spare parts from a Yamaha dealer.

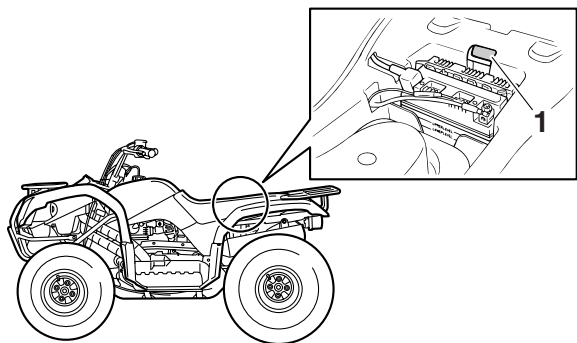

1. Model label

INDEX

- A**
Accessories and loading 6-6
Air filter elements, engine and V-belt filter cleaning 8-17
- B**
Battery 5-6, 8-41
Brake lever free play, adjusting the front 8-28
Brake lever free play (rear), adjusting 8-32
Brake lever, front 4-4
Brake lever, rear 4-5
Brake levers, checking and lubricating 8-38
Brakes 8-27
Brakes, front and rear 5-3
Brake shoes, checking the front and rear 8-27
- C**
Cables, checking and lubricating 8-37
Carburetor, adjusting 8-25
Carrier, front 4-11
Carrier, rear 4-11
Chassis fasteners 5-6
Cleaning 9-1
- D**
Drive chain 5-3
Drive chain, lubricating 8-36
Drive chain slack 8-34
Drive select lever 4-6
Drive select lever and driving in reverse 6-3
- E**
Engine break-in 6-4
Engine, cold start 6-1
Engine idling speed 8-25
Engine oil 5-3, 8-11
Engine, starting a warm 6-2
Engine stop switch 4-2
- F**
Front knuckle pivots, lubricating 8-40
Fuel 4-7, 5-3
Fuel cock 4-8
Fuel tank cap 4-7
Fuse, replacing 8-44
- H**
Handlebar switches 4-2
Headlight beam, adjusting 8-46
Headlight bulb, replacing 8-44
Horn switch 4-3
- I**
Identification numbers 11-1
Indicator lights 4-2
Instruments, lights and switches 5-6
- L**
Label locations 1-1
Light switch 4-3
- M**
Main switch 4-1
Maintenance and lubrication chart 8-5
Maintenance chart, emission control system 8-3
Model label 11-2

N

Neutral indicator light 4-2

O

Owner's manual and tool kit 8-2

P

Parking 6-5

Parking brake 4-5

Parking on a slope 6-5

Part locations 3-1

R

Reverse indicator light 4-2

Riding your ATV 7-1

S

Safety information 2-1

Seat 4-10

Spark arrester, cleaning 8-23

Spark plug, checking 8-9

Specifications 10-1

Speed limiter 4-4

Starter (choke) 4-10

Start switch 4-3

Steering shaft, lubricating 8-40

Storage 9-2

Suspension, lubricating the lower arm pivots 8-39

T

Tail/brake light bulb, replacing 8-47

Throttle lever 4-3, 5-3

Throttle lever free play, adjusting 8-26

Tires 5-3

Transmission oil 5-3, 8-14

Troubleshooting 8-49

Troubleshooting chart 8-50

V

Valve clearance 8-27

V-belt case drain screw 8-24

Vehicle identification number 11-1

W

Wheel hub bearings, checking 8-38

Wheel, installing 8-48

Wheel, removing 8-47



PRINTED ON RECYCLED PAPER

PRINTED IN JAPAN
2011.03-0.2×1 CR
(E)