



OWNER'S MANUAL

**⚠ Read this manual carefully
before operating this vehicle.**

TMAX

MOTORCYCLE

XP560E (TMAX)

XP560D (TMAX TECH MAX)

B3T-28199-E0

Safety information	1
Description	2
Smart key system	3
Special features	4
Instrument and control functions	5
For your safety – pre-operation checks	6
Operation and important riding points	7
Periodic maintenance and adjustment	8
Scooter care and storage	9
Specifications	10
Consumer information	11
Index	12

 **Read this manual carefully before operating this vehicle. This manual should stay with this vehicle if it is sold.**

Declaration of Conformity:

Hereby, MITSUBISHI ELECTRIC CORPORATION, HIMEJI WORKS declares that the radio equipment type, Smart Keyless System, SKEA7B-01 (Smart Unit) and SKEA7B-03 (Hand Unit) is in compliance with Directive 2014/53/EU.

The full text of the EU declaration of conformity is available at the following internet address:

<http://www.mitsubishielectric.com/bu/automotive/doc/re.html>

REMOTE CONT. UNIT (Smart Unit)

Frequency band: 125 kHz

The maximum radio frequency power: 107 dB μ V/m at. 10 meters

XMTR COMP. (Hand Unit)

Frequency band: 433.92 MHz

The maximum radio frequency power: 10 mW

Manufacturer:

MITSUBISHI ELECTRIC CORPORATION, HIMEJI WORKS

840, Chiyoda-machi, Himeji, Hyogo 670-8677, Japan

Importer:

YAMAHA MOTOR EUROPE N.V.

Koolhovenlaan 101, 1119 NC Schiphol-Rijk, 1117 ZN, Schiphol, the Netherlands

TIP

For XP560D: This model is equipped with My TMAX Connect GPS system. This system must be activated before it can be used. Please refer to the Vodafone Customer Portal User Guide for instructions on how to register and activate the system.

www.my-tmax-connect.eu

Welcome to the Yamaha world of motorcycling!

As the owner of the XP560E / XP560D, you are benefiting from Yamaha's vast experience and newest technology regarding the design and manufacture of high-quality products, which have earned Yamaha a reputation for dependability.

Please take the time to read this manual thoroughly, so as to enjoy all advantages of your XP560E / XP560D. The Owner's Manual does not only instruct you in how to operate, inspect and maintain your scooter, but also in how to safeguard yourself and others from trouble and injury.

In addition, the many tips given in this manual will help keep your scooter in the best possible condition. If you have any further questions, do not hesitate to contact your Yamaha dealer.

The Yamaha team wishes you many safe and pleasant rides. So, remember to put safety first!

Yamaha continually seeks advancements in product design and quality. Therefore, while this manual contains the most current product information available at the time of printing, there may be minor discrepancies between your scooter and this manual. If there is any question concerning this manual, please consult a Yamaha dealer.







Please read this manual carefully and completely before operating this scooter.

Important manual information

EAU10134

Particularly important information is distinguished in this manual by the following notations:

	This is the safety alert symbol. It is used to alert you to potential personal injury hazards. Obey all safety messages that follow this symbol to avoid possible injury or death.
	A WARNING indicates a hazardous situation which, if not avoided, could result in death or serious injury.
	A NOTICE indicates special precautions that must be taken to avoid damage to the vehicle or other property.
	A TIP provides key information to make procedures easier or clearer.

*Product and specifications are subject to change without notice.

EAU10201

**XP560E / XP560D
OWNER'S MANUAL**
©2020 by Yamaha Motor Co., Ltd.
1st edition, August 2019
All rights reserved.
Any reprinting or unauthorized use
without the written permission of
Yamaha Motor Co., Ltd.
is expressly prohibited.
Printed in Japan.

Table of contents

Safety information	1-1	Indicator lights and warning lights	5-2	Tips for reducing fuel consumption	7-4
Further safe-riding points	1-5	Speedometer	5-4	Parking.....	7-4
Description	2-1	Tachometer	5-5	Periodic maintenance and adjustment	8-1
Left view	2-1	Multi-function display.....	5-5	Tool kit	8-2
Right view	2-2	Front brake lever	5-18	Periodic maintenance charts	8-3
Controls and instruments	2-3	Rear brake lever	5-18	Periodic maintenance chart for the emission control system	8-3
Smart key system	3-1	Rear brake lock lever	5-18	General maintenance and lubrication chart	8-5
Smart key system	3-1	Anti-lock brake system (ABS)	5-19	Removing and installing panels.....	8-9
Operating range of the smart key system.....	3-2	Fuel tank cap	5-20	Checking the spark plugs.....	8-11
Handling of the smart key and mechanical key	3-3	Fuel	5-21	Canister	8-12
Smart key	3-5	Fuel tank overflow hose	5-22	Engine oil and oil filter cartridge ...	8-12
Replacing the smart key battery.....	3-6	Catalytic converter	5-23	Why Yamalube.....	8-15
Powering on the vehicle	3-7	Storage compartments	5-23	Coolant	8-15
Powering off the vehicle	3-8	Windshield (XP560E).....	5-25	Replacing the engine air filter element and cleaning the check hose.....	8-17
How to lock the steering	3-9	Rear view mirrors	5-26	Checking the engine idling speed	8-18
How to lock the centerstand	3-10	Shock absorber assembly	5-27	Checking the throttle grip free play.....	8-18
Storage compartment and fuel tank access.....	3-11	Auxiliary DC jack.....	5-28	Valve clearance.....	8-19
Parking mode	3-13	Sidestand	5-29	Tires	8-19
Special features	4-1	Ignition circuit cut-off system	5-30	Cast wheels	8-21
Cruise control system (XP560D).....	4-1	For your safety – pre-operation checks	6-1	Checking the front and rear brake lever free play	8-22
D-mode (drive mode).....	4-3	Operation and important riding points	7-1		
Traction control system.....	4-4	Engine break-in	7-1		
Instrument and control functions	5-1	Starting the engine.....	7-2		
Handlebar switches	5-1	Starting off	7-3		
		Acceleration and deceleration	7-3		
		Braking.....	7-3		

Table of contents

Adjusting the rear brake lock cable	8-22	Storage	9-3
Checking the rear brake lock	8-23	Specifications	10-1
Checking the front and rear brake pads	8-24	Consumer information	11-1
Checking the brake fluid level	8-24	Identification numbers	11-1
Changing the brake fluid	8-25	Diagnostic connector	11-2
Drive belt	8-26	Vehicle data recording	11-2
Checking and lubricating the cables	8-27	Index	12-1
Checking and lubricating the throttle grip and cable	8-27		
Lubricating the front and rear brake levers	8-27		
Checking and lubricating the centerstand and sidestand	8-28		
Checking the front fork	8-29		
Checking the steering	8-29		
Checking the wheel bearings	8-30		
Battery	8-30		
Replacing the fuses	8-31		
Vehicle lights	8-34		
Replacing the license plate light bulb	8-34		
Troubleshooting	8-35		
Troubleshooting chart	8-36		
Emergency mode	8-38		
Scooter care and storage	9-1		
Matte color caution	9-1		
Care	9-1		

Be a Responsible Owner

As the vehicle's owner, you are responsible for the safe and proper operation of your scooter.

Scooters are single-track vehicles.

Their safe use and operation are dependent upon the use of proper riding techniques as well as the expertise of the operator. Every operator should know the following requirements before riding this scooter.

He or she should:

- Obtain thorough instructions from a competent source on all aspects of scooter operation.
- Observe the warnings and maintenance requirements in this Owner's Manual.
- Obtain qualified training in safe and proper riding techniques.
- Obtain professional technical service as indicated in this Owner's Manual and/or when made necessary by mechanical conditions.

- Never operate a scooter without proper training or instruction. Take a training course. Beginners should receive training from a certified instructor. Contact an authorized scooter dealer to find out about the training courses nearest you.

Safe Riding

Perform the pre-operation checks each time you use the vehicle to make sure it is in safe operating condition. Failure to inspect or maintain the vehicle properly increases the possibility of an accident or equipment damage. See page 6-1 for a list of pre-operation checks.

- This scooter is designed to carry the operator and a passenger.
- The failure of motorists to detect and recognize scooters in traffic is the predominating cause of automobile/scooter accidents. Many accidents have been caused by an automobile driver who did not see the scooter. Making yourself

conspicuous appears to be very effective in reducing the chance of this type of accident.

Therefore:

- Wear a brightly colored jacket.
- Use extra caution when you are approaching and passing through intersections, since intersections are the most likely places for scooter accidents to occur.
- Ride where other motorists can see you. Avoid riding in another motorist's blind spot.
- Never maintain a scooter without proper knowledge. Contact an authorized scooter dealer to inform you on basic scooter maintenance. Certain maintenance can only be carried out by certified staff.

- Many accidents involve inexperienced operators. In fact, many operators who have been involved in accidents do not even have a current driver's license.
 - Make sure that you are qualified and that you only lend your scooter to other qualified operators.
 - Know your skills and limits. Staying within your limits may help you to avoid an accident.
 - We recommend that you practice riding your scooter where there is no traffic until you have become thoroughly familiar with the scooter and all of its controls.
- Many accidents have been caused by error of the scooter operator. A typical error made by the operator is veering wide on a turn due to excessive speed or undercornering (insufficient lean angle for the speed).
 - Always obey the speed limit and never travel faster than warranted by road and traffic conditions.
- Always signal before turning or changing lanes. Make sure that other motorists can see you.
- The posture of the operator and passenger is important for proper control.
 - The operator should keep both hands on the handlebar and both feet on the operator footrests during operation to maintain control of the scooter.
 - The passenger should always hold onto the operator, the seat strap or grab bar, if equipped, with both hands and keep both feet on the passenger footrests. Never carry a passenger unless he or she can firmly place both feet on the passenger footrests.
- Never ride under the influence of alcohol or other drugs.
- This scooter is designed for on-road use only. It is not suitable for off-road use.

Protective Apparel

The majority of fatalities from scooter accidents are the result of head injuries. The use of a safety helmet is the single most critical factor in the prevention or reduction of head injuries.

- Always wear an approved helmet.
- Wear a face shield or goggles. Wind in your unprotected eyes could contribute to an impairment of vision that could delay seeing a hazard.
- The use of a jacket, substantial shoes, trousers, gloves, etc., is effective in preventing or reducing abrasions or lacerations.
- Never wear loose-fitting clothes, otherwise they could catch on the control levers or wheels and cause injury or an accident.
- Always wear protective clothing that covers your legs, ankles, and feet. The engine or exhaust system become very hot during or after operation and can cause burns.
- A passenger should also observe the above precautions.

Safety information

1

Avoid Carbon Monoxide Poisoning

All engine exhaust contains carbon monoxide, a deadly gas. Breathing carbon monoxide can cause headaches, dizziness, drowsiness, nausea, confusion, and eventually death.

Carbon Monoxide is a colorless, odorless, tasteless gas which may be present even if you do not see or smell any engine exhaust. Deadly levels of carbon monoxide can collect rapidly and you can quickly be overcome and unable to save yourself. Also, deadly levels of carbon monoxide can linger for hours or days in enclosed or poorly ventilated areas. If you experience any symptoms of carbon monoxide poisoning, leave the area immediately, get fresh air, and SEEK MEDICAL TREATMENT.

- Do not run engine indoors. Even if you try to ventilate engine exhaust with fans or open windows and doors, carbon monoxide can rapidly reach dangerous levels.
- Do not run engine in poorly ventilated or partially enclosed areas such as barns, garages, or carports.

- Do not run engine outdoors where engine exhaust can be drawn into a building through openings such as windows and doors.

Loading

Adding accessories or cargo to your scooter can adversely affect stability and handling if the weight distribution of the scooter is changed. To avoid the possibility of an accident, use extreme caution when adding cargo or accessories to your scooter. Use extra care when riding a scooter that has added cargo or accessories. Here, along with the information about accessories below, are some general guidelines to follow if loading cargo to your scooter:

The total weight of the operator, passenger, accessories and cargo must not exceed the maximum load limit.

Operation of an overloaded vehicle could cause an accident.

Maximum load:

195 kg (430 lb) (XP560D)
197 kg (434 lb) (XP560E)

When loading within this weight limit, keep the following in mind:

- Cargo and accessory weight should be kept as low and close to the scooter as possible. Securely pack your heaviest items as close to the center of the vehicle as possible and make sure to distribute the weight as evenly as possible on both sides of the scooter to minimize imbalance or instability.
- Shifting weights can create a sudden imbalance. Make sure that accessories and cargo are securely attached to the scooter before riding. Check accessory mounts and cargo restraints frequently.
- Properly adjust the suspension for your load (suspension-adjustable models only), and check the condition and pressure of your tires.
- Never attach any large or heavy items to the handlebar, front fork, or front fender. Such items can create unstable handling or a slow steering response.

- **This vehicle is not designed to pull a trailer or to be attached to a sidecar.**

Genuine Yamaha Accessories

Choosing accessories for your vehicle is an important decision. Genuine Yamaha accessories, which are available only from a Yamaha dealer, have been designed, tested, and approved by Yamaha for use on your vehicle.

Many companies with no connection to Yamaha manufacture parts and accessories or offer other modifications for Yamaha vehicles. Yamaha is not in a position to test the products that these aftermarket companies produce. Therefore, Yamaha can neither endorse nor recommend the use of accessories not sold by Yamaha or modifications not specifically recommended by Yamaha, even if sold and installed by a Yamaha dealer.

Aftermarket Parts, Accessories, and Modifications

While you may find aftermarket products similar in design and quality to genuine Yamaha accessories, recog-

nize that some aftermarket accessories or modifications are not suitable because of potential safety hazards to you or others. Installing aftermarket products or having other modifications performed to your vehicle that change any of the vehicle's design or operation characteristics can put you and others at greater risk of serious injury or death. You are responsible for injuries related to changes in the vehicle.

Keep the following guidelines in mind, as well as those provided under "Loading" when mounting accessories.

- Never install accessories or carry cargo that would impair the performance of your scooter. Carefully inspect the accessory before using it to make sure that it does not in any way reduce ground clearance or cornering clearance, limit suspension travel, steering travel or control operation, or obscure lights or reflectors.
- Accessories fitted to the handlebar or the front fork area can create instability due to improper weight distribution or aerodynamic changes. If accessories

are added to the handlebar or front fork area, they must be as lightweight as possible and should be kept to a minimum.

- Bulky or large accessories may seriously affect the stability of the scooter due to aerodynamic effects. Wind may attempt to lift the scooter, or the scooter may become unstable in cross winds. These accessories may also cause instability when passing or being passed by large vehicles.
- Certain accessories can displace the operator from his or her normal riding position. This improper position limits the freedom of movement of the operator and may limit control ability, therefore, such accessories are not recommended.
- Use caution when adding electrical accessories. If electrical accessories exceed the capacity of the scooter's electrical system, an electric failure could result, which could cause a dangerous loss of lights or engine power.

Safety information

1

Aftermarket Tires and Rims

The tires and rims that came with your scooter were designed to match the performance capabilities and to provide the best combination of handling, braking, and comfort. Other tires, rims, sizes, and combinations may not be appropriate. Refer to page 8-19 for tire specifications and more information on replacing your tires.

Transporting the Scooter

Be sure to observe following instructions before transporting the scooter in another vehicle.

- Remove all loose items from the scooter.
- Point the front wheel straight ahead on the trailer or in the truck bed, and choke it in a rail to prevent movement.
- Secure the scooter with tie-downs or suitable straps that are attached to solid parts of the scooter, such as the frame or upper front fork triple clamp (and not, for example, to rubber-mounted handlebars or turn signals, or parts that could break). Choose the lo-

cation for the straps carefully so the straps will not rub against painted surfaces during transport.

- The suspension should be compressed somewhat by the tie-downs, if possible, so that the scooter will not bounce excessively during transport.

EAU57600

Further safe-riding points

- Be sure to signal clearly when making turns.
- Braking can be extremely difficult on a wet road. Avoid hard braking, because the scooter could slide. Apply the brakes slowly when stopping on a wet surface.
- Slow down as you approach a corner or turn. Once you have completed a turn, accelerate slowly.
- Be careful when passing parked cars. A driver might not see you and open a door in your path.
- Railroad crossings, streetcar rails, iron plates on road construction sites, and manhole covers become extremely slippery when wet. Slow down and cross them with caution. Keep the scooter upright, otherwise it could slide out from under you.
- The brake pads or linings could get wet when you wash the scooter. After washing the scooter, check the brakes before riding.

- Always wear a helmet, gloves, trousers (tapered around the cuff and ankle so they do not flap), and a brightly colored jacket.
- Do not carry too much luggage on the scooter. An overloaded scooter is unstable. Use a strong cord to secure any luggage to the carrier (if equipped). A loose load will affect the stability of the scooter and could divert your attention from the road. (See page 1-3.)

Description

EAU10411

Left view

2

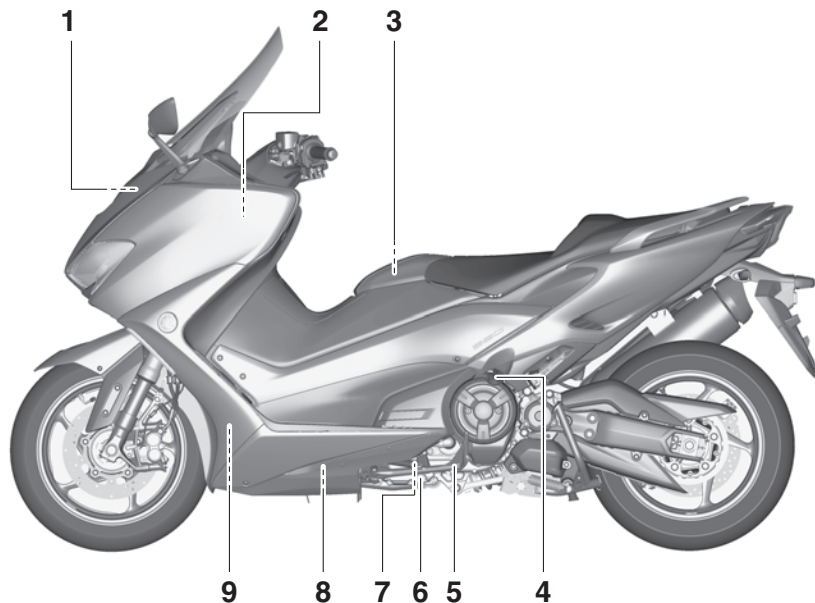

1. Fuses (page 8-31)

2. Battery (page 8-30)

3. Fuel tank cap (page 5-20)

4. Engine oil filler cap (page 8-12)

5. Sidestand (page 5-29)

6. Engine oil drain bolt (page 8-12)

7. Engine oil level check window (page 8-12)

8. Oil filter cartridge (page 8-12)

9. Coolant level check window (page 8-15)

Right view

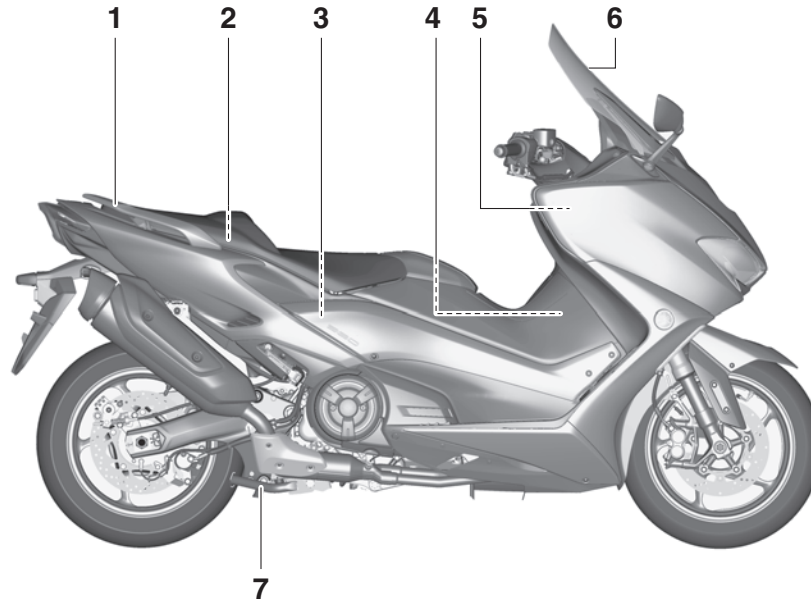

1. Grab bar (page 7-3)
2. Tool kit (page 8-2)
3. Rear storage compartment (page 5-23)
4. Air filter element (page 8-17)
5. Front storage compartment (page 5-23)
6. Windshield (page 5-25/5-8)
7. Centerstand (page 8-28)

Controls and instruments

2

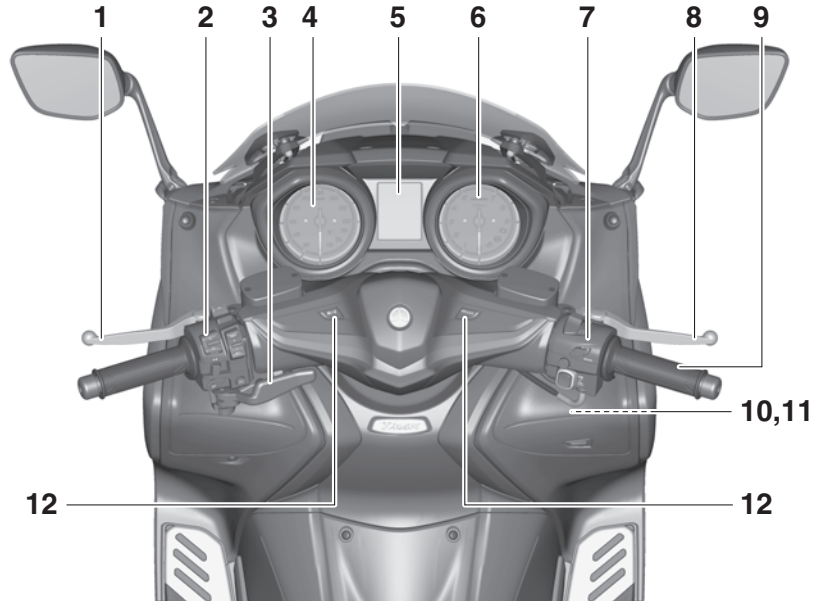

1. Rear brake lever (page 5-18)
2. Left handlebar switches (page 5-1)
3. Rear brake lock lever (page 5-18)
4. Speedometer (page 5-4)
5. Multi-function display (page 5-5)
6. Tachometer (page 5-5)
7. Right handlebar switches (page 5-1)
8. Front brake lever (page 5-18)

9. Throttle grip (page 8-18)
10. Front storage compartment (page 5-23)
11. Auxiliary DC jack (page 5-28)
12. Smart key system switches (page 3-1)

Smart key system

The smart key system enables the vehicle to be operated without using a mechanical key.

EAU77202

EWA14704

WARNING

- **Keep implanted pacemakers or cardiac defibrillators, as well as other electric medical devices away from the vehicle mounted antenna (see illustration).**
- **Radio waves transmitted by the antenna may affect the operation of such devices when close by.**
- **If you have an electric medical device, consult a doctor or the device manufacturer before using this vehicle.**

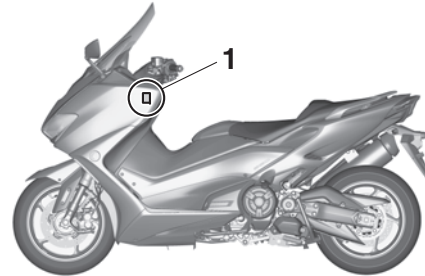

1. Vehicle mounted antenna

In addition to the vehicle mounted antenna, the smart key system consists of the smart key, smart key system indicator light, “ON/⊘” switch, and the “OFF/LOCK” and “ ” switches.

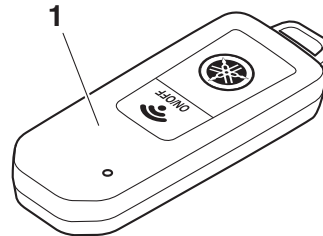

1. Smart key



1. Smart key system indicator light “ ”

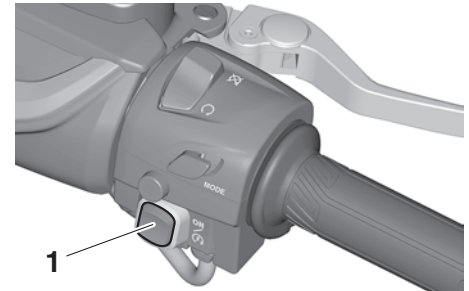

1. “ON/⊘” switch

Smart key system

3

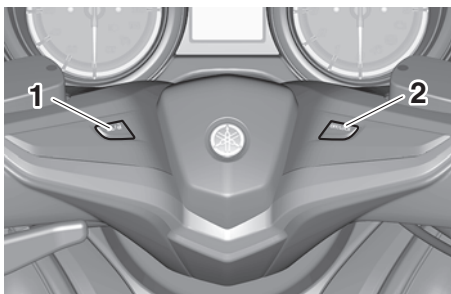

1. "OFF/LOCK" switch
2. "Smart Key" switch

ECA15764

NOTICE

The smart key system uses weak radio waves. The smart key system may not work in the following situations.

- The smart key is placed in a location exposed to strong radio waves or other electromagnetic noise
- There are facilities nearby that are emitting strong radio waves (TV or radio towers, power plants, broadcasting stations, airports, etc.)

- You are carrying or using communication equipment such as radios or mobile phones in close proximity of the smart key
- The smart key is in contact with or covered by a metallic object
- Other vehicles equipped with a smart key system are nearby

In such situations, move the smart key to another location and perform the operation again. If it still does not work, use the mechanical key to carry out the operation in emergency mode. (See page 8-38.)

EAU77214

Operating range of the smart key system

The operating range of the smart key system is about 80 cm (31.5 in) from the center of the handlebars.

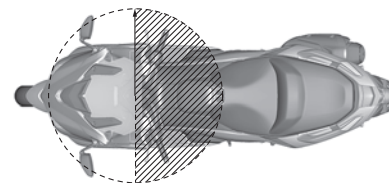
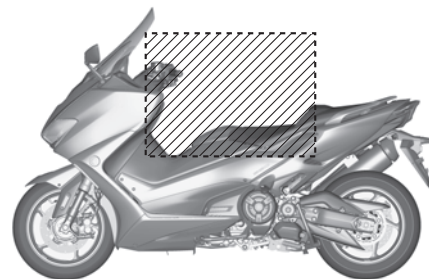

TIP

- As the smart key system uses weak radio waves, the operating range may be affected by the surrounding environment.
- When the battery of the smart key is discharged, the smart key may not work or its operating range become very small.
- If the smart key is turned off, the vehicle will not recognize the smart key even if it is within operating range.
- If the “ON/⊘” switch, “OFF/LOCK” switch, or “/⊘” switch are repeatedly pressed when the smart key is out of range or cannot communicate with the vehicle, all switches will be temporarily disabled.
- Placing the smart key in the front or rear storage compartment may block communication between the smart key and the vehicle. If the rear trunk or front storage compartment is locked with the smart key inside, the smart key

system may be disabled. The smart key should always be carried on your person.

EWA17952

WARNING

- **The smart key should be carried with you. Do not store it on the vehicle.**
- **When the smart key is within operating range, exercise due care because other people not carrying the smart key can start the engine and operate the vehicle.**

Handling of the smart key and mechanical key

Included with the vehicle is one smart key (with a built-in mechanical key) and one spare mechanical key with an identification card. Keep the spare mechanical key and card separate from the smart key. Should you lose or damage the smart key, or when its battery is discharged, the mechanical key will serve as a back up. The seat can be opened, the smart key system identification number can be manually input, and then the vehicle can be operated. (See page 8-38.) We recommend that you **note down the identification number in case of emergency.**

Smart key system

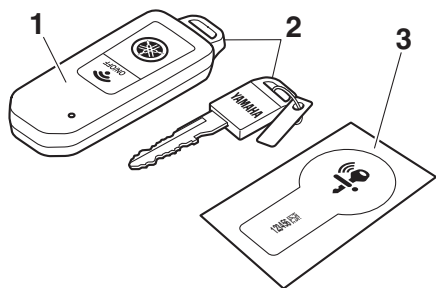

1. Smart key
2. Mechanical key
3. Identification number card

If the smart key and identification card of the mechanical key are both lost or damaged, and there is no record of the identification number, the entire smart key system will need to be replaced.

ECA21573

NOTICE

The smart key has precision electronic components. Observe the following precautions to prevent possible malfunction or damage.

- Do not place or store the smart key in a storage compartment. The smart key may be damaged from road vibrations or excessive heat.

- Do not drop, bend, or subject the smart key to strong impacts.
- Do not submerge the smart key in water or other liquids.
- Do not place heavy items or excessive stress on the smart key.
- Do not leave the smart key in a place exposed to direct sunlight, high temperature or high humidity.
- Do not grind or attempt to modify the smart key.
- Keep the smart key away from strong magnetic fields and magnetic objects such as key holders, TVs, and computers.
- Keep the smart key away from electric medical equipment.
- Do not allow oils, polishing agents, fuel, or any strong chemicals to come in contact with the smart key. The smart key body may become discolored or cracked.

TIP

- The smart key battery life is approximately two years, but this may vary according to operating conditions.
- The smart key battery may become discharged even if it is away from the vehicle and not being used.
- If the smart key continually receives radio waves, the smart key battery will discharge quickly. (For example, when placed in the vicinity of electrical products such as televisions, radios, or computers.)

Replace the smart key battery when the smart key system indicator light flashes for about 20 seconds when the vehicle is first power on, or when the smart key indicator light does not come on when the “ON/OFF” switch is pushed. (See page 3-6.) After changing the smart key battery, if the smart key system still does not operate, have a Yamaha dealer check the vehicle.

EAU77223

TIP

- You can register up to six smart keys for the same vehicle. See a Yamaha dealer regarding spare smart keys.
- If a smart key is lost, contact a Yamaha dealer immediately to prevent the vehicle from being stolen.

Smart key

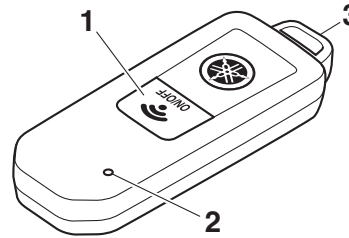

1. "ON/OFF" switch
2. Smart key indicator light
3. Mechanical key

When the smart key is turned on and brought within range, the smart key system allows you to operate the vehicle without inserting a mechanical key. If the smart key is turned off, the vehicle cannot be operated even if the smart key is within operating range of the vehicle.

The current status of the key can be checked by briefly pressing the "ON/OFF" switch.

- Short flash: the key is on
- Long flash: the key is off

To turn the smart key on or off

To turn the smart key on or off, press the "ON/OFF" switch for one second. The smart key indicator light will flash. If the key does a short flash, the key is on. If the key does a long flash, the key is off.

TIP

To preserve the vehicle battery power, the smart key system will turn off automatically about a week after the vehicle is last used. In this case, press the "ON/⊕" switch once to turn on the smart key system, and then once more to turn on the vehicle power.

To use the mechanical key

Pull out the mechanical key from the smart key body. After using the mechanical key, insert it back into the smart key.

Smart key system

EAU79071

Replacing the smart key battery

Replace the battery in the following situations.

3

- The smart key system indicator light flashes for about 20 seconds when the power of the vehicle is turned on.
- When the smart key indicator light does not come on when the “ON/OFF” switch is pushed.

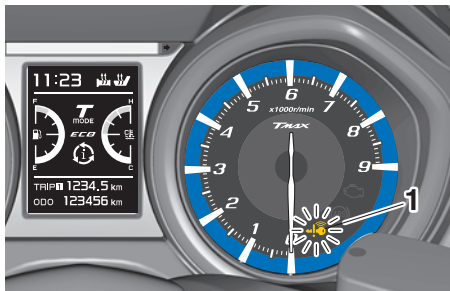

1. Smart key system indicator light “

EWA20630

WARNING

The smart key contains a button cell battery.

- Keep new and used batteries away from children.

- If the battery compartment does not close securely, stop using the smart key and keep it away from children.

Explosion Hazard - do not mishandle the battery.

- Danger of explosion if battery is incorrectly replaced.
- Replace only with the same or equivalent type.
- Do not expose smart key to excessive heat, such as sunshine or fire.

Chemical Burn Hazard - do not ingest the battery.

- If the battery is swallowed, it can cause severe internal burns in just 2 hours and can lead to death.
- If you think batteries might have been swallowed or placed inside any part of the body, seek immediate medical attention.

ECA24010

NOTICE

- Do not apply excessive force to the smart key when replacing the battery.
- Do not use a screwdriver or other hard object to force open the key.
- Take precautions to prevent the waterproof seal from being damaged or contaminated by dirt.
- Do not touch the internal circuits and terminals. This may cause malfunctions.
- Make sure the battery is installed correctly. Confirm the direction of the positive/“+” side of the battery.

To replace the smart key battery

1. Gently pry open the smart key case.

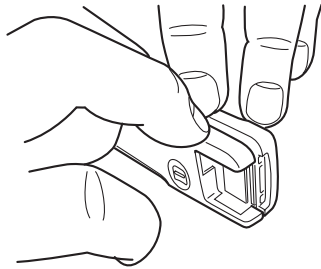

2. Remove the battery cover and O-ring.

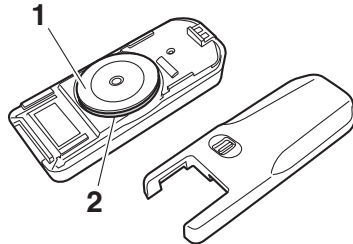

1. Battery cover
2. O-ring

3. Remove the battery.

TIP _____
Dispose of the removed battery in accordance with local regulations.

4. Install a new battery as shown. Note the polarity of the battery.

Specified battery:
CR2025

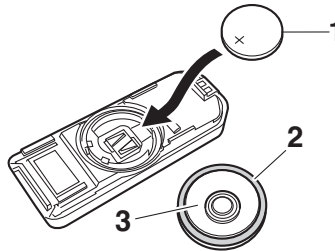

1. Battery
2. O-ring
3. Battery cover

5. Install the O-ring and battery cover.
6. Gently snap the smart key case closed.

Powering on the vehicle

1. With the smart key on and in operating range, briefly press the “ON/⊞” switch.

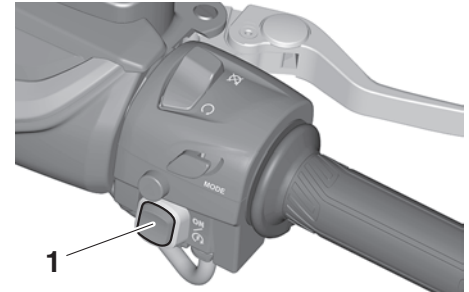

1. “ON/⊞” switch

2. Upon authentication of the smart key, the beeper will sound twice and the smart key system indicator light will come on briefly. All locks will release automatically.

TIP _____
● The smart key system indicator light will flash if the steering lock cannot automatically release itself. Try moving the handlebars gently to the left or right and then press the “ON/⊞” switch one more time.

Smart key system

3

- If the steering continues to be locked and will not release, the smart key system indicator light will flash slowly. Move the handlebar gently to the left and right to help release the steering lock and then press the “ON/⊗” switch again.
- The smart key system indicator light will flash if the centerstand lock cannot automatically release itself. Gently rock the vehicle forward or backward and then press the “ON/⊗” switch one more time.
- If the centerstand continues to be locked and will not release, the smart key system indicator light will flash slowly. Rock the vehicle forward and backward to help release the centerstand lock and then press the “ON/⊗” switch again.

ECA15826

NOTICE

If the steering lock or centerstand lock will not release and the smart key system indicator light is flashing, have a Yamaha dealer check the smart key system.

3. The power of the vehicle is turned on when all locks have been released. The multi-function display will come on.
4. The engine can now be started. (See page 7-2.)

TIP

See page 8-38 for information about emergency mode and how to turn the vehicle power on without the smart key.

EAU78033

Powering off the vehicle

To turn the vehicle power off and stop the engine if it is running, press the “OFF/LOCK” switch.

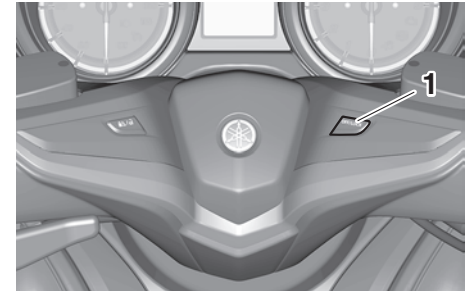

1. “OFF/LOCK” switch

Upon authentication of the smart key, the beeper will sound once to confirm that the vehicle power has been successfully turned off and the storage compartment and fuel tank cap lid locks will be released.

TIP

- The rider must turn off the power of the vehicle manually.
- The power of the vehicle will not turn off automatically even if the smart key is moved out of operating range of the smart key system.

- The power of the vehicle cannot be turned off via the “OFF/LOCK” switch when the vehicle is moving.

If the smart key is not within operating range or cannot communicate with the vehicle when you press the “OFF/LOCK” switch, the vehicle will not be turned off and the beeper will sound for three seconds (the smart key system indicator light will also flash) to alert you that the power was not successfully turned off. Confirm the location and condition of the smart key and try powering off the vehicle again.



TIP

Without the smart key, the vehicle power can be turned off by pressing the “OFF/LOCK” switch again while the smart key system indicator light is flashing.

Auto lock function

After the engine is stopped via the “OFF/LOCK” switch and also whenever the vehicle power is turned from on to off, all storage compartment locks and the fuel tank cap lid lock are re-

leased. When 60 seconds have passed, all compartments will automatically lock.

When the compartment locks are released via the “  ” switch, the compartments will automatically lock after 10 seconds have passed.

How to lock the steering

With the vehicle power off, turn the handlebars fully to the left and then briefly press the “OFF/LOCK” switch.

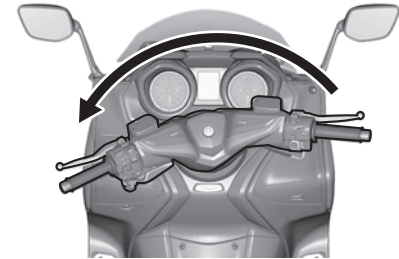

TIP

- If the steering lock function locks correctly, the beeper will sound once.
- If the steering lock function does not lock correctly, the beeper will sound for three seconds and the smart key system indicator light will flash. Turn the handlebar fully to the left one more time and press the “OFF/LOCK” switch again.

Smart key system

EWA14742

⚠ WARNING

Do not operate the steering lock while the vehicle is moving.

3

EAU78052

How to lock the centerstand

Park the vehicle on a firm level surface and then place it on the centerstand. Press the “OFF/LOCK” switch for one second.

vehicle forward or backward and press the “OFF/LOCK” switch for one second.

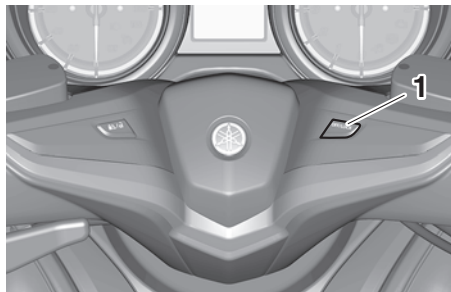

1. “OFF/LOCK” switch

TIP

- If the centerstand lock function locks correctly, the beeper will sound once.
- If the centerstand lock function does not lock correctly, the beeper will sound for three seconds and the smart key system indicator light will flash. Gently rock the

Storage compartment and fuel tank access

EAU81291

To open the seat

1. Place the vehicle on the center-stand.
2. Briefly press the “/” switch. Upon authentication of the smart key, the beeper will sound twice.

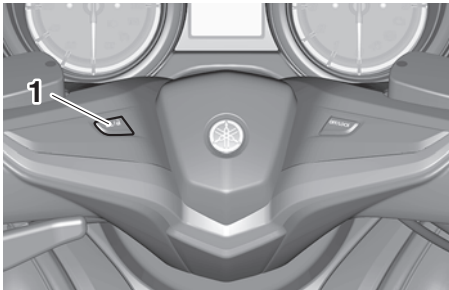

1. “/” switch

3. Press the “SEAT” button and the seat lock will release.

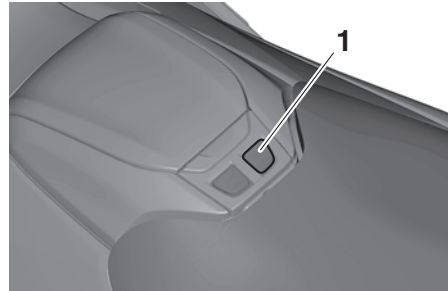

1. “SEAT” button

4. Fold the seat up.



To close the seat

Fold the seat down, and then push it to lock it in place.

TIP

- Make sure the seat is properly closed before starting off.

- In case of an emergency, the seat can be opened with a mechanical key. (See page 8-38.)

To open the fuel tank cap lid

With the smart key on and in operating range, briefly press the “/” switch. Upon authentication of the smart key, the beeper will sound twice.

1. Press the “FUEL” button.

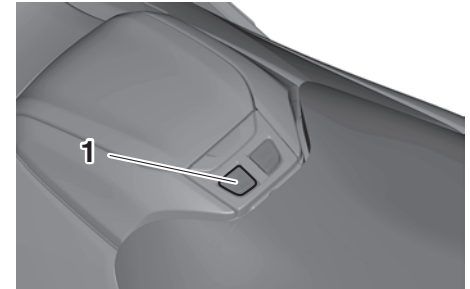

1. “FUEL” button

2. Open the lid as shown.

Smart key system

3

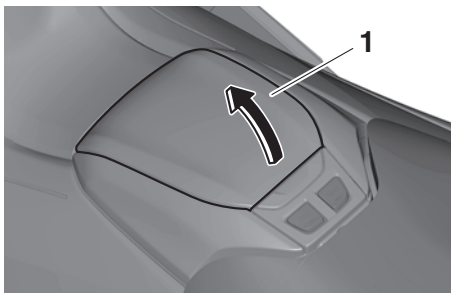

1. Fuel tank cap lid

To close the fuel tank cap lid

Push the lid to the original position.

To open the front storage compartment lid (XP560D)

With the smart key on and in operating range, briefly press the “/” switch. Upon authentication of the smart key, the beeper will sound twice.

1. Press the button on the center of the front storage compartment lid.

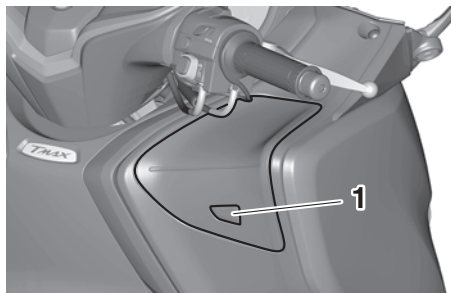

1. Button

2. Open the front storage compartment as shown.

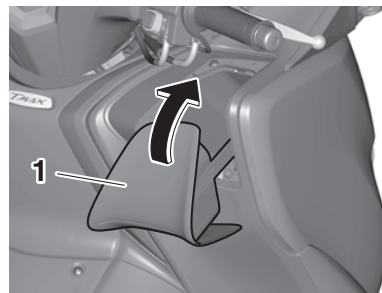

1. Lid

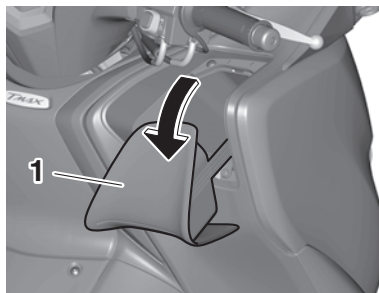

1. Lid

To close the front storage compartment lid

Push the lid into the original position.

EAU80842

ECA20760

Parking mode

The steering is locked, and the hazard lights and turn signal lights can be turned on, but all other electrical systems are off.

To enter parking mode

1. Lock the steering. (See page 3-9.)
2. Press the “ ” switch for one second.

TIP

If the steering lock has not been applied, the beeper will sound for 3 seconds (the smart key system indicator light will also flash) and the vehicle will not enter parking mode.

3. Upon authentication of the smart key, the beeper will sound twice and the vehicle will enter parking mode. The smart key system indicator light will come on.

TIP

The seat, fuel tank cap lid, and the front storage compartment (for XP560D) cannot be opened while in parking mode.

NOTICE

Using the hazard or turn signal lights for an extended length of time may cause the battery to discharge.

To exit parking mode

Press the “ ” switch. Upon authentication of the smart key, the beeper will sound once and the smart key system indicator light will go off.

Special features

Cruise control system (XP560D)

EAU77264

The cruise control system is designed to maintain a set cruising speed between about 50 km/h (31 mi/h) and 140 km/h (87 mi/h).

EWA20950

WARNING

- **Improper use of the cruise control system may result in loss of control, which could lead to an accident. Do not activate the cruise control system in heavy traffic, poor weather conditions, or among winding, slippery, hilly, rough or gravel roads.**
- **When traveling uphill or downhill, the cruise control system may not be able to maintain the set cruising speed.**
- **To prevent accidentally activating the cruise control system, turn it off when not in use. Make sure that the cruise control system indicator light “**

1. Cruise control setting indicator light “**SET**”
2. Cruise control system indicator light “

1. Cruise control setting switch “RES+/SET-”
2. Cruise control power switch “

Activating the cruise control system

1. Push the cruise control power switch “
 2. Push the “SET-” side of the cruise control setting switch to activate the cruise control system. Your current traveling speed will become the set cruising speed. The cruise control setting indicator light “**SET**” will come on.

Adjusting the set cruising speed

While the cruise control system is operating, push the “RES+” side of the cruise control setting switch to increase the set cruising speed or the “SET-” side to decrease the set speed.

TIP

Pushing the setting switch once will change the speed in increments of approximately 2.0 km/h (1.2 mi/h). Holding down the “RES+” or “SET-” side of the cruise control setting switch will increase or decrease the speed continuously until the switch is released.

You can also manually increase your traveling speed using the throttle. After you have accelerated, you can set a new cruising speed by pushing the “SET-” side of the setting switch. If you do not set a new cruising speed, when

you return the throttle grip, the vehicle will decelerate to the previously set cruising speed.

Deactivating the cruise control system

Perform one of the following operations to cancel the set cruising speed. The “**SET**” indicator light will turn off.

- Turn the throttle grip past the closed position in the deceleration direction.

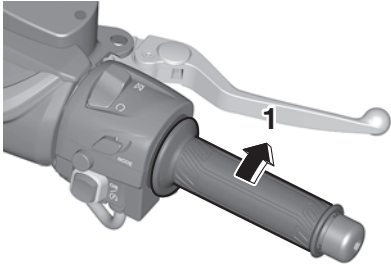

1. Deceleration direction

- Apply the front or rear brake.

TIP

Traveling speed decreases as soon as the cruise control system is deactivated; unless the throttle grip is turned.

Using the resume function

Push the “RES+” side of the cruise control setting switch to reactivate the cruise control system. The traveling speed will return to the previously set cruising speed. The “**SET**” indicator light will come on.

EWA16351

⚠ WARNING

It is dangerous to use the resume function when the previously set cruising speed is too high for current conditions.

Turning off the cruise control system

Push the cruise control power switch “

TIP

Whenever the cruise control system or the vehicle power is turned off, the previously set cruising speed is erased. You will not be able to use the resume function until a new cruising speed has been set.

Automatic deactivation of the cruise control system

The cruise control system is electronically controlled and linked with other control systems. The cruise control system will automatically deactivate under the following conditions:

- The cruise control system is not able to maintain the set cruising speed (such as when going up a steep hill).
- Wheel slip or wheel spin is detected. (If the traction control system is on, traction control will engage.)
- Engine trouble, etc.

If the cruise control system is automatically deactivated, the “

If the cruise control system was automatically deactivated, please stop and confirm that your vehicle is in good operating condition before continuing on. When traveling on roads with steep grades, the cruise control system may not be able to maintain the set cruising speed.

Special features

4

- When going uphill, the actual traveling speed may become lower than the set cruising speed. If this occurs, accelerate to the desired traveling speed using the throttle.
- When going downhill, the actual traveling speed may become higher than the set cruising speed. If this occurs, the setting switch cannot be used to adjust the set cruising speed. To reduce the traveling speed, apply the brakes. When the brakes are applied, the cruise control system will deactivate.

D-mode (drive mode)

EAU81392

D-mode is an electronically controlled engine performance system with two mode selections (touring mode “T” and sports mode “S”).

EWA18440



Do not change the drive mode while the vehicle is moving.

With the throttle grip closed, push the drive mode switch “MODE” to switch between modes “S” (sports) and “T” (touring).

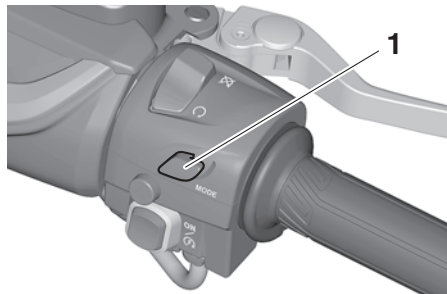

1. Drive mode switch “MODE”

TIP

- The current drive mode is shown in the drive mode display (page 5-7).
- The current drive mode is saved when the vehicle is turned off.
- D-mode cannot be changed while cruise control (XP560D) is activated.

Touring mode “T”

The touring mode “T” is suitable for various riding conditions. This mode allows the rider to enjoy smooth drivability from the low-speed range to the high-speed range.

Sports mode “S”

This mode offers a sportier engine response in the low- to mid-speed range compared to the touring mode.

EAU88850

Traction control system

The traction control system (TCS) helps maintain traction when accelerating on slippery surfaces, such as unpaved or wet roads. If sensors detect that the rear wheel is starting to slip (uncontrolled spinning), the traction control system assists by regulating engine power as needed until traction is restored.

When traction control has engaged, the “TCS” indicator light will flash. You may notice changes in engine response or exhaust sounds.

EWA18860

WARNING

The traction control system is not a substitute for riding appropriately for the conditions. Traction control cannot prevent loss of traction due to excessive speed when entering turns, when accelerating hard at a sharp lean angle, or while braking, and cannot prevent front wheel slipping. As with any vehicle, approach surfaces that may be slippery with caution and avoid especially slippery surfaces.

Setting the traction control system

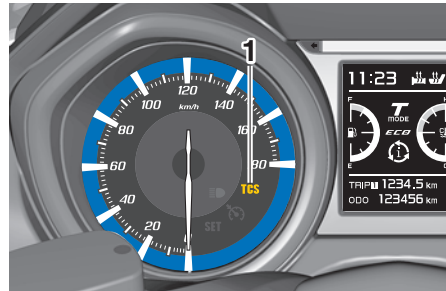

1. Traction control system indicator light “TCS”

When the vehicle is turned on, traction control is automatically turned on.

To turn the traction control system off, see page 5-11.

TIP

Turn the traction control system off to help free the rear wheel if the vehicle gets stuck in mud, sand, or other soft surfaces.

ECA16801

NOTICE

Use only the specified tires. (See page 8-19.) Using different sized tires will prevent the traction control system from controlling tire rotation accurately.

Resetting the traction control system

The traction control system will automatically disable under certain conditions; such as when a sensor fault is detected, or when only one wheel is allowed to rotate for more than a few seconds. Should this happen, the “TCS” indicator light will come on.

TIP

When the vehicle is on the centerstand, do not rev the engine for an extended period of time. Otherwise, the traction control system will automatically disable and need to be reset.

If the traction control system automatically disables, reset it by riding under normal conditions.

Special features

TIP

If the “**TCS**” indicator light remains on after resetting, the vehicle may still be ridden; however, have a Yamaha dealer check the vehicle as soon as possible.

Handlebar switches

EAU77490

Left

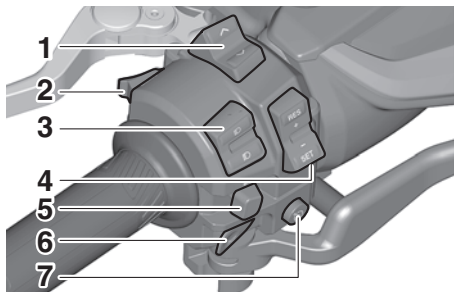

1. Select switch “”
2. Menu switch “MENU”
3. Dimmer/Pass switch “//PASS”
4. Cruise control setting switch “RES+/SET-” (XP560D)
5. Turn signal switch “/”
6. Horn switch “”
7. Cruise control power switch “” (XP560D)

Right

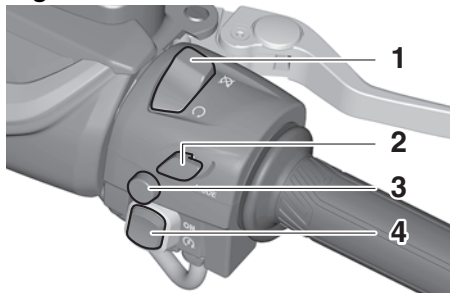

1. Engine stop switch “/”
2. Drive mode switch “MODE”
3. Hazard switch “”
4. Power on/Starter switch “ON/”

Dimmer/Pass switch “//PASS”

EAU88260

Set this switch to “” for the high beam and to “” for the low beam.

To flash the high beam, press the switch down to “PASS” while the headlights are on low beam.

TIP

- When the switch is set to low beam, the inner two headlights come on.

- When the switch is set to high beam, the outer two headlights come on.

Turn signal switch “/”

EAU66040

To signal a right-hand turn, push this switch to “”. To signal a left-hand turn, push this switch to “”. When released, the switch returns to the center position. To cancel the turn signal lights, push the switch in after it has returned to the center position.

Horn switch “”

EAU66030

Press this switch to sound the horn.

Engine stop switch “/”

EAU77450

Set this switch to “” before starting the engine. Set this switch to “” to stop the engine in case of an emergency, such as when the vehicle overturns or when the throttle cable is stuck.

Power on/Starter switch “ON/”

EAU77291

With the smart key turned on and within range, press this switch to turn on the power to the vehicle. Then with the

Instrument and control functions

sidestand up and while applying the front or rear brake, push this switch to crank the engine with the starter. See page 7-2 for starting instructions prior to starting the engine.

Hazard switch “ EAU79601

With the vehicle power is on or in parking mode, use this switch to turn on the hazard lights (simultaneous flashing of all turn signal lights).

The hazard lights are used in case of an emergency or to warn other drivers when your vehicle is stopped where it might be a traffic hazard.

ECA10062

NOTICE

Do not use the hazard lights for an extended length of time with the engine not running, otherwise the battery may discharge.

EAU73951

Cruise control switches

See page 4-1 for an explanation of the cruise control system.

Menu switch “MENU”

EAU77301

This switch is used to make setting changes within the multi-function display. (See page 5-5.)

Select switch “/ EAU77311

This switch is used to make setting changes within the multi-function display. (See page 5-5.)

Drive mode switch “MODE”

EAU73931

See page 4-3 for an explanation of the drive mode.

Indicator lights and warning lights

EAU77122

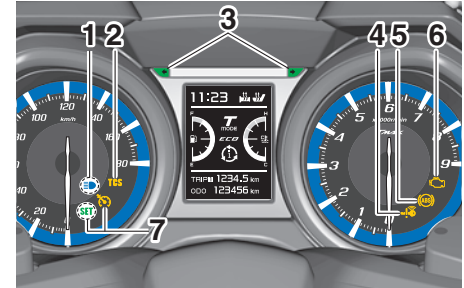

1. High beam indicator light “

Turn signal indicator lights “ EAU88680

Each indicator light will flash when its corresponding turn signal lights are flashing.

High beam indicator light “” EAU88690

This indicator light comes on when the high beam of the headlight is switched on.

Cruise control indicator lights EAU77550

See page 4-1 for an explanation of these indicator lights.

Malfunction indicator light (MIL) “” EAU88710

This light comes on or flashes if a problem is detected in the engine or other vehicle control system. If this occurs, have a Yamaha dealer check the on-board diagnostic system. The electrical circuit of the warning light can be checked by vehicle power on. The light should come on for a few seconds, and then go off. If the light does not come on initially when the vehicle power on, or if the light remains on, have a Yamaha dealer check the vehicle.

NOTICE

If the MIL starts flashing, reduce engine speed to prevent exhaust system damage.

TIP

The engine is sensitively controlled for the on-board diagnostic system to detect deterioration and malfunction of the emission control system. Due to this specification, the MIL may come on or flash for vehicle modifications, lack of maintenance, or excessive or improper use of the motorcycle. To prevent this, observe these precautions.

- Do not attempt to modify the software of the engine control unit.
- Do not add any electrical accessories that interfere with engine control.
- Do not use aftermarket accessories or parts such as suspension, spark plugs, injectors, exhaust system, etc.
- Do not change drivetrain specifications (chain, sprockets, wheels, tires, etc.).

ECA26820

- Do not remove or alter the O2 sensor, air induction system, or exhaust parts (catalysts or EXUP, etc.).
- Maintain proper V-belt and drive belt (if equipped).
- Maintain correct tire pressure.
- Do not operate the vehicle in an extreme manner. For example, repeated or excessive opening and closing of the throttle, racing, burnouts, wheelies, etc.

ABS warning light “” EAU77075

This warning light comes on when a problem is detected with the ABS. (See page 5-19.)

When the vehicle power is turned on, this light will come on and then go off after reaching a traveling speed of 10 km/h (6 mi/h). If the warning light:

- does not come on when the vehicle power is turned on
- does not go off after traveling at a speed of 10 km/h (6 mi/h) or higher
- comes on or flashes while riding

Instrument and control functions

the anti-lock brake system may not work correctly. Have a Yamaha dealer check the vehicle as soon as possible.

EWA16043

WARNING

If the ABS warning light does not turn off after reaching 10 km/h (6 mi/h), or if the warning light comes on while riding:

- Use extra caution to avoid possible wheel lock during emergency braking.
- Have a Yamaha dealer check the vehicle as soon as possible.

TIP

The ABS warning light may come on when revving the engine with the scooter on its centerstand, but this does not indicate a malfunction.

EAU88700

Traction control system indicator light “TCS”

This indicator light will flash when traction control has engaged. If the traction control system is turned off, this indicator light will come on.

TIP

When the vehicle is turned on, the light should come on for a few seconds and then go off. If the light does not come on, or if the light remains on, have a Yamaha dealer check the vehicle.

EAU78083

Smart key system indicator light “

This indicator light will flash when communication between the vehicle and smart key takes place and when certain smart key system operations are carried out.

The indicator light may also flash when there is an error in the smart key system.

TIP

When the vehicle is turned on, the light should come on for a few seconds and then go off. If the light does not come on, or if the light remains on, have a Yamaha dealer check the vehicle.

Speedometer

EAU77131

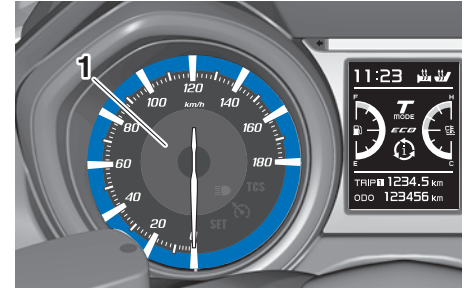

1. Speedometer

The speedometer shows the vehicle's traveling speed.

When the vehicle power is turned on, the speedometer needle will sweep across the speed range and return to zero in order to test the electrical circuit.

Tachometer

EAU77141

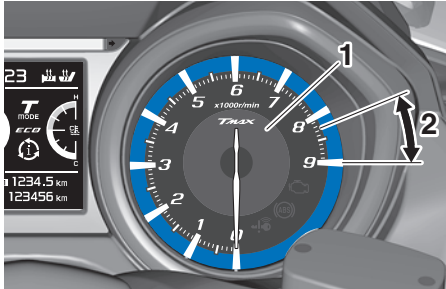

1. Tachometer
2. High-r/min zone

The tachometer shows the engine speed in crankshaft revolutions per minute (r/min).

When the vehicle power is turned on, the tachometer needle will sweep across the r/min range and return to zero in order to test the electrical circuit.

ECA23050

NOTICE

Do not operate the engine in the tachometer high-r/min zone.

High-r/min zone: 8250 r/min and above

Multi-function display

EAU7733A

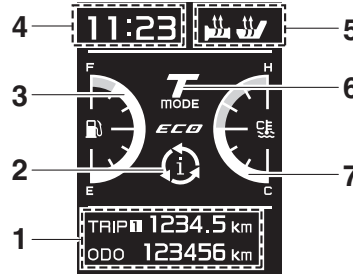

1. Information display
2. Function select icon
3. Fuel meter
4. Clock
5. Grip warmer/Seat heater icons
6. Drive mode display
7. Coolant temperature meter

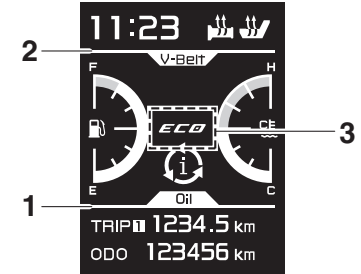

1. Oil change indicator "Oil"
2. V-belt replacement indicator "V-Belt"
3. Eco indicator "ECO"

EWA12313

WARNING

Be sure to stop the vehicle before making any setting changes to the multi-function display. Changing settings while riding can distract the operator and increase the risk of an accident.

TIP

Certain multi-function display items can be adjusted via the setting mode. (See page 5-11.)

Instrument and control functions

Fuel meter

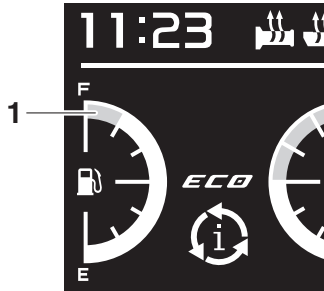

1. Fuel meter

The fuel meter indicates the amount of fuel in the fuel tank. The display segments of the fuel meter disappear from “F” (full) towards “E” (empty) as the fuel level decreases. When the last segment starts flashing, refuel as soon as possible.

TIP _____

If a problem is detected in the fuel meter electrical circuit, the fuel meter will flash repeatedly. Have a Yamaha dealer check the vehicle.

Coolant temperature meter

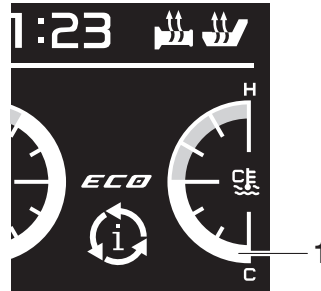

1. Coolant temperature meter

The coolant temperature varies with changes in the weather and engine load. If the top segment starts flashing, the information display automatically changes to “C-TEMP” and “Hi” flashes. Stop the vehicle and let the engine cool. (See page 8-37.)

TIP _____

The information display cannot be changed while the engine is overheating.

ECA10022

NOTICE _____

Do not continue to operate the engine if it is overheating.

Eco indicator

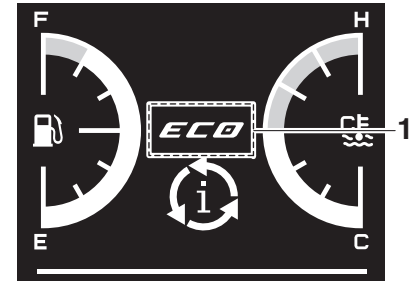

1. Eco indicator “ECO”

This indicator comes on when the vehicle is being operated in an environmentally friendly, fuel-efficient manner. The indicator goes off when the vehicle is stopped.

TIP _____

Consider the following tips to reduce fuel consumption:

- Avoid high engine speeds during acceleration.
- Travel at a constant speed.

Drive mode display

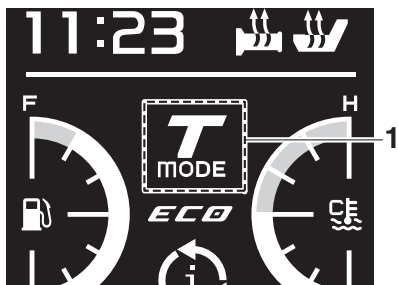

1. Drive mode display

This display indicates which drive mode has been selected: “S” sporty or “T” touring. (See page 4-3.)

V-belt replacement indicator



1. V-belt replacement indicator “V-Belt”

This indicator flashes every 20000 km (12500 mi) when the V-belt needs to be replaced.

After changing the V-belt, reset the V-belt replacement indicator. (See page 5-13.)

TIP

If the V-belt is changed before the V-belt replacement indicator flashes, the indicator must be reset in order for the next periodic V-belt change to be indicated at the correct time.

Oil change indicator

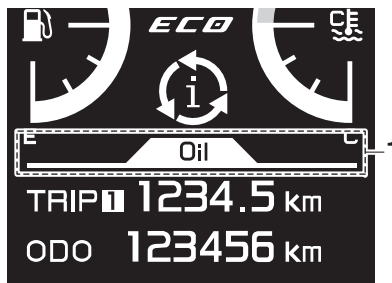

1. Oil change indicator “Oil”

This indicator flashes at the initial 1000 km (600 mi), then at 5000 km (3000 mi) and every 5000 km (3000 mi) thereafter to indicate that the engine oil should be changed.

After changing the engine oil, reset the oil change indicator. (See page 5-13.)

TIP

If the engine oil is changed before the oil change indicator flashes, the indicator must be reset in order for the next periodic oil change to be indicated at the correct time.

Grip warmer/Seat heater icons



1. Grip warmer/Seat heater icons

Each icon will appear when the grip warmer or seat heater is in use.

Instrument and control functions

Function selection

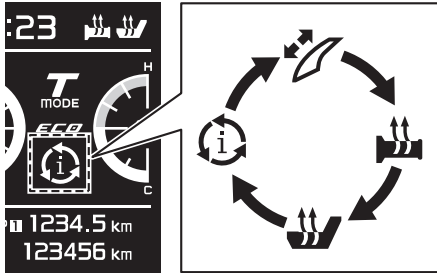

5

Push the “MENU” switch to switch among the windshield adjusting function, grip warmer adjusting function, seat heater adjusting function, and information display selection function.

TIP

For XP560E: The windshield, grip warmer, and seat heater cannot be selected. However, the grip warmer can be selected by attaching accessory parts.

Adjusting the windshield position

To move the windshield up, push the “^” side of the select switch. To move the windshield down, push the “v” side of the select switch.

Adjusting the grip warmer

This vehicle can be equipped with grip warmers, which can only be used when the engine is running. There are 4 grip warmer settings.

Setting	Display
Off	
Low	
Middle	
High	

To increase the grip warmer temperature, push the “^” side of the select switch. To decrease the grip warmer temperature, push the “v” side of the select switch.

ECA17932

NOTICE

- Be sure to wear gloves when using the grip warmers.
- Do not use the grip warmers in warm weather.

- If the handlebar grip or throttle grip becomes worn or damaged, stop using the grip warmers and replace the grips.

Adjusting the seat heater

This vehicle can be equipped with a seat heater, which can only be used when the vehicle is running. There are 4 seat heater settings.

Setting	Display
Off	
Low	
Middle	
High	

To increase the seat heater temperature, push the “^” side of the select switch. To decrease the seat heater temperature, push the “v” side of the select switch.

Instrument and control functions

ECA23980

NOTICE

- Be sure to wear protective clothing that covers your hip and legs when using the seat heater.
- If the ambient temperature is 20 °C (68 °F) or higher, do not set the seat heater to the high setting.
- If the seat becomes worn or damaged, stop using the seat heater and replace the seat.

Changing the information display

The information display items are grouped into 3 display pages.

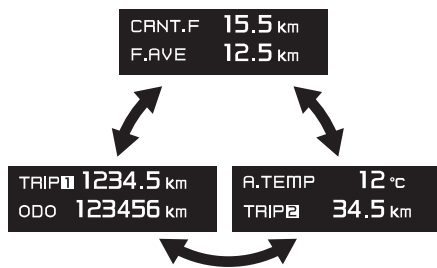

Push the “^” or “v” side of the select switch to rotate among the 3 display pages.

TIP

The items for each display page can be customized. (See page 5-15.)

Odometer:

ODO 123456 km

The odometer shows the total distance traveled by the vehicle.

Tripmeters:

TRIP1 1234.5 km

TRIP2 34.5 km

“TRIP1” and “TRIP2” show the distance traveled since they were last set to zero.

To reset a tripmeter, use the select switch to select the information display page that contains the tripmeter you want to reset. Push the “^” side of the select switch for one second so that the tripmeter flashes, and then push the “^” side of the select switch again for one second while the tripmeter is flashing.

TIP

- The odometer will lock at 999999.
- The tripmeters will reset and continue counting after 9999.9 is reached.

F-TRIP 4.5 km

When approximately 3.0 L (0.79 US gal, 0.66 Imp.gal) of fuel remains in the fuel tank, the last segment of the fuel meter starts flashing. In addition, the information display will automatically change to the fuel reserve tripmeter mode “F-TRIP” and start counting the distance traveled from that point.

Instrument and control functions

In this case, push the select switch to switch the display in the following order:

F-TRIP ↔ Display-1 ↔ Display-2
↔ Display-3 ↔ F-TRIP

If you do not reset the fuel reserve trip-meter manually, it will reset automatically after refueling and traveling 5 km (3 mi).

TIP

You cannot enter setting mode (page 5-11) while “F-TRIP” is on.

Estimated traveling range:



RANGE 123 km

The estimated distance that can be traveled with the remaining fuel under the current riding conditions is shown.

Ambient temperature:



A.TEMP 12°C

This shows the ambient temperature from -9 °C to 50 °C in 1 °C increments. The temperature displayed may vary from the actual ambient temperature.

TIP

- -9 °C will be displayed even if the detected temperature is lower.
- 50 °C will be displayed even if the detected temperature is higher.
- The accuracy of the temperature reading may be affected when riding under 20 km/h (12 mi/h) or when stopped at traffic signals and railroad crossings.

Average fuel consumption:



F.AVE 12.5 km/L

The average fuel consumption mode “F.AVE” can be set to “km/L” or “L/100km”. For UK-spec vehicles: “MPG”. (See page 5-14.)

To reset the average fuel consumption, use the select switch to select the information display page that contains the average fuel consumption display. Push the “^” side of the select switch so that the average fuel consumption display flashes, and then push the “^” side of the select switch again for 1 second while the display is flashing.

TIP

After resetting the average fuel consumption display, “-.-” will be shown until the vehicle has traveled 1 km (0.6 mi).

NOTICE

If there is a malfunction, “-.-” will be continuously displayed. Have a Yamaha dealer check the vehicle.

ECA15474

Instantaneous fuel consumption:



The instantaneous fuel consumption mode “CRNT.F” can be set to “km/L” or “L/100km”. For UK-spec vehicles: “MPG”. (See page 5-14.)

TIP

If traveling at speeds under 10 km/h (6 mi/h), “- -.-” will be displayed.

ECA15474

NOTICE

If there is a malfunction, “- -.-” will be continuously displayed. Have a Yamaha dealer check the vehicle.

Setting mode

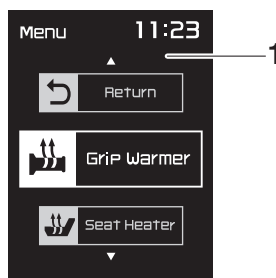

1. Setting mode display

Stop the vehicle and then push the “MENU” switch for 2 seconds to enter the setting mode. To exit the setting mode and return to the standard display mode, push the “MENU” switch again for 2 seconds or select “Return”.

TIP

When the malfunction indicator light is on, setting mode cannot be entered.

Menu items

Category	Description
Grip Warmer	This function allows you to set the low, middle, and high settings to 10 temperature levels.

Seat Heater	This function allows you to set the low, middle, and high settings to 10 temperature levels.
Traction Control	This function allows you to turn the traction control system on or off.
Maintenance	This function allows you to check and reset the oil change interval (indicator), V-Belt change interval (indicator), and the “FREE” maintenance interval.
Unit	This function allows you to switch the fuel consumption units between “L/100km” and “km/L”. For UK-spec vehicles: this function is not available.
Display	This function allows you to change the items shown in 3 information displays.
Brightness	This function allows you to adjust the brightness of the instrument panel.
Clock	This function allows you to set the clock.
All Reset	This function allows you to reset all items to their factory preset or default settings; excepting the odometer, clock, and maintenance counter items “Oil” and “V-Belt”.

Instrument and control functions

Grip warmer settings

1. Use the select switch to highlight “Grip Warmer”.



2. Push the “MENU” switch. The grip warmer setting display will be shown.

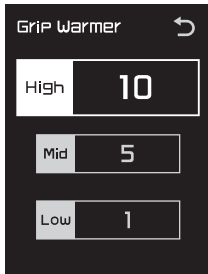

3. Push the “MENU” switch. The temperature level for the high setting will be highlighted.

Use the select switch to set the temperature level, and then push the “MENU” switch.

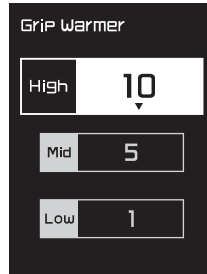

4. Use the select switch to highlight “Mid” or “Low”, and then change the setting using the same procedure that was used for the high setting.
5. When you finished changing the settings, use the select switch to highlight “↶”, and then push the “MENU” switch to return to the menu screen.

Seat heater settings

1. Use the select switch to highlight “Seat Heater”.

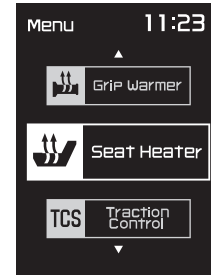

2. Push the “MENU” switch. The seat heater setting display will be shown.

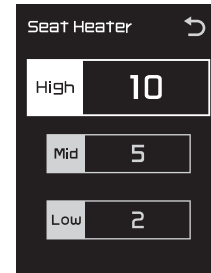

3. Push the “MENU” switch. The temperature level for the high setting will be highlighted. Use the select switch to set the temperature level, and then push the “MENU” switch.

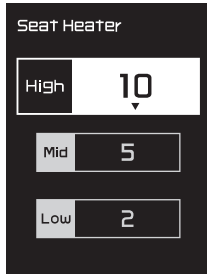

4. Use the select switch to highlight “Mid” or “Low”, and then change the setting using the same procedure that was used for the high setting.
5. When you finished changing the settings, use the select switch to highlight “↵”, and then push the “MENU” switch to return to the menu screen.

Traction control system settings

1. Use the select switch to highlight “Traction Control”.

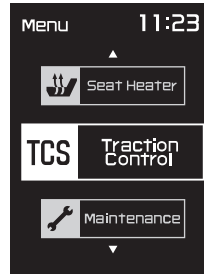

2. Push the “MENU” switch. The traction control system setting display will be shown.

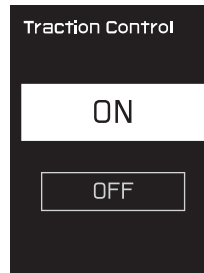

3. To set the traction control system to “OFF”, push the select switch “∨” side for 2 seconds.

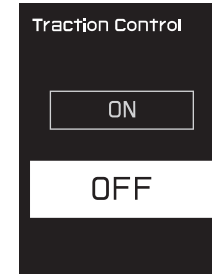

4. To set the traction control system to “ON” again, push the select switch “∧”.

TIP

When the vehicle is powered on, the traction control system is automatically set to “ON”.

5. When you finished changing the settings, push the “MENU” switch to return to the menu screen.

Resetting the maintenance counters

1. Use the select switch to highlight “Maintenance”.

Instrument and control functions

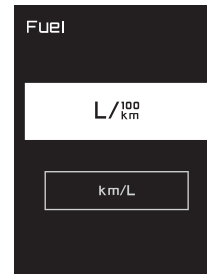
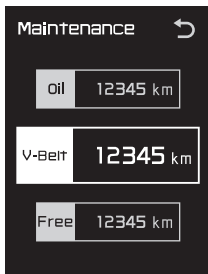
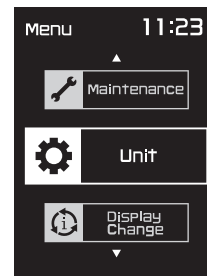
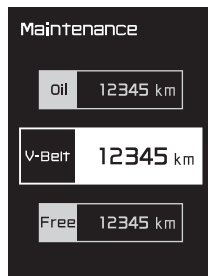
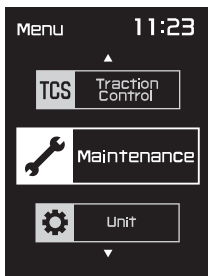

5

2. Push the “MENU” switch, and then use the select switch to select the item to reset.

3. Push the “MENU” switch, and after the selected item is highlighted, push the select switch “^” for one second.

4. When you finished resetting, use the select switch to highlight “↩”, and then push the “MENU” switch to return to the menu screen.

2. Push the “MENU” switch. The unit setting display will be shown.

3. Use the select switch to select “L/100km” or “km/L”.

Selecting the units

TIP

U.K. specification vehicles only: This function does not indicate on setting mode display and cannot be selected.

1. Use the select switch to highlight “Unit”.

Instrument and control functions

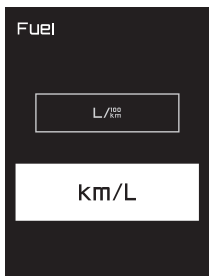

4. Push the “MENU” switch to make the selection and return to the menu screen.

Selecting the display items

1. Use the select switch to highlight “Display Change”.

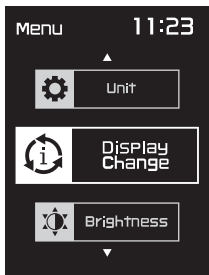

2. Push the “MENU” switch, use the select switch to highlight the display to change, and then push the “MENU” switch again.

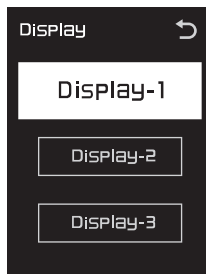

3. Use the select switch to highlight the item to change, and then push the “MENU” switch.

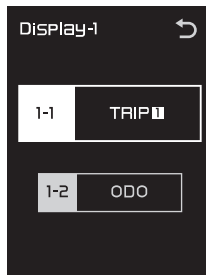

TIP

Display item order is as follows.

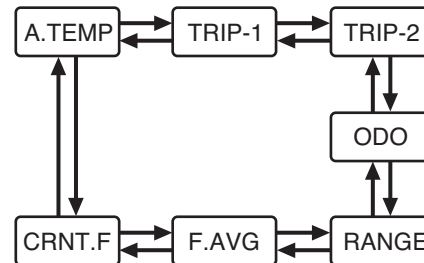

4. Use the select switch to select the item to show, and then push the “MENU” switch.

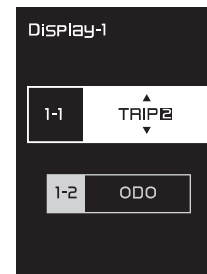

Instrument and control functions

- When you finished changing the settings, use the select switch to highlight “↵”, and then push the “MENU” switch to return to the previous display.
- Use the select switch to highlight “↵”, and then push the “MENU” switch to return to the menu screen.

5

Meter panel brightness

- Use the select switch to highlight “Brightness”.

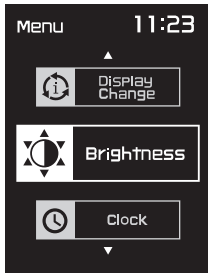

- Push the “MENU” switch.
- Use the select switch to select the desired brightness level.



- Push the “MENU” switch to return to the menu screen.

Setting the clock

TIP

The clock uses a 12-hour time system.

- Use the select switch to highlight “Clock”.

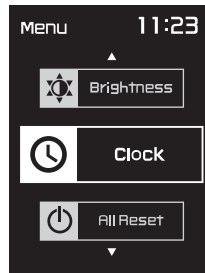

- Push the “MENU” switch.
- When the hour digits are highlighted, use the select switch to set the hours.

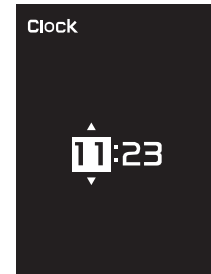

- Push the “MENU” switch, and the minute digits are highlighted.

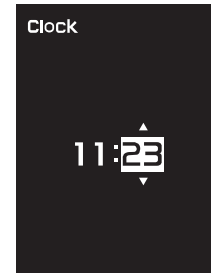

- Use the select switch to set the minutes.

Instrument and control functions

6. Push the “MENU” switch to return to the menu screen.

Resetting all of the display items

1. Use the select switch to highlight “All Reset”.

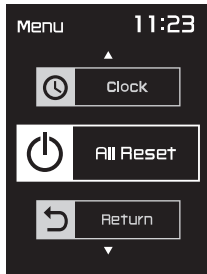

2. Push the “MENU” switch.
3. Use the select switch to highlight “YES”, and then push the “MENU” switch. All items are reset to factory preset or default settings.



TIP

The odometer, clock, maintenance counter item “Oil” and maintenance counter item “V-Belt” will not be reset.

To exit the setting mode

1. Use the select switch to highlight “Return”.



2. Push the “MENU” switch to exit the setting mode and return to the standard display mode.

Instrument and control functions

5

Front brake lever

EAU44916

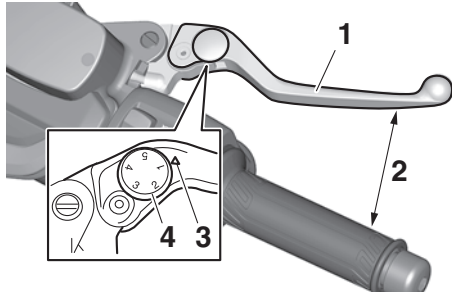

1. Front brake lever
2. Distance
3. Match mark
4. Brake lever position adjusting dial

The front brake lever is located on the right side of the handlebar. To apply the front brake, pull this lever toward the throttle grip.

The front brake lever is equipped with a brake lever position adjusting dial. To adjust the distance between the front brake lever and the throttle grip, push the brake lever away from the throttle grip and rotate the adjusting dial. Make sure the setting number on the adjusting dial aligns with the match mark on the brake lever.

Rear brake lever

EAU44926

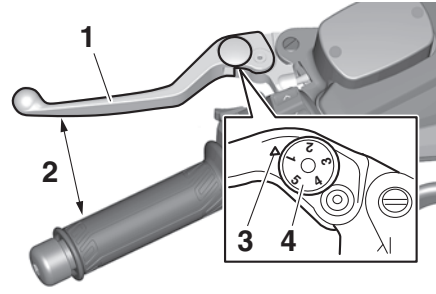

1. Rear brake lever
2. Distance
3. Match mark
4. Brake lever position adjusting dial

The rear brake lever is located at the left handlebar grip. To apply the rear brake, pull this lever toward the handlebar grip.

The rear brake lever is equipped with a brake lever position adjusting dial. To adjust the distance between the rear brake lever and the handlebar grip, push the brake lever away from the handlebar grip and rotate the adjusting dial. Make sure the setting number on the adjusting dial aligns with the match mark on the brake lever.

Rear brake lock lever

EAU63230

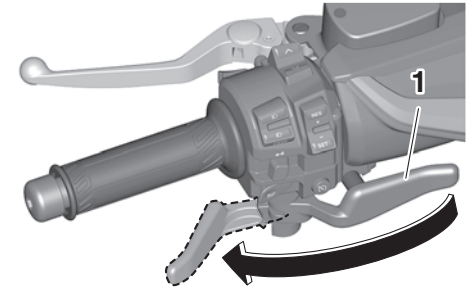

1. Rear brake lock lever

This vehicle is equipped with a rear brake lock lever to prevent the rear wheel from moving while stopped at traffic signals, railroad crossings, etc.

To lock the rear wheel

Push the rear brake lock lever to the left until it snaps into place.

To unlock the rear wheel

Push the rear brake lock lever back to the original position.

TIP

Be sure to check that the rear wheel does not move when the rear brake lock lever is applied.

EWA12362



WARNING

Never move the rear brake lock lever to the left while the vehicle is moving, otherwise loss of control or an accident may result. Make sure that the vehicle is stopped before moving the rear brake lock lever to the left.

Anti-lock brake system (ABS)

EAU65582

This model's ABS features a dual electronic control system, which acts on the front and rear brakes independently.

Operate the brakes with ABS as you would conventional brakes. If the ABS is activated, a pulsating sensation may be felt at the brake levers. In this situation, continue to apply the brakes and let the ABS work; do not "pump" the brakes as this will reduce braking effectiveness.

EWA16051



WARNING

Always keep a sufficient distance from the vehicle ahead to match the riding speed even with ABS.

- The ABS performs best with long braking distances.
- On certain surfaces, such as rough or gravel roads, the braking distance may be longer with the ABS than without.

The ABS is monitored by an ECU, which will revert the system to conventional braking if a malfunction occurs.

TIP

- The ABS performs a self-diagnosis test each time the vehicle is turned on and travels at a speed of 10 km/h (6 mi/h) or higher. During this test, a clicking noise can be heard and if either brake lever is even slightly applied, a vibration can be felt at the lever, but this does not indicate a malfunction.
- This ABS has a test mode which allows the owner to experience the pulsation at the brake levers when the ABS is operating. However, special tools are required, so please consult your Yamaha dealer.

ECA20100

NOTICE

Be careful not to damage the wheel sensor or wheel sensor rotor; otherwise, improper performance of the ABS will result.

Instrument and control functions

5

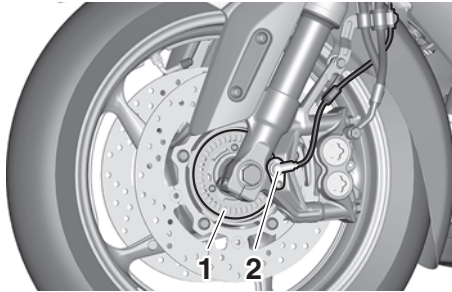

1. Front wheel sensor rotor
2. Front wheel sensor

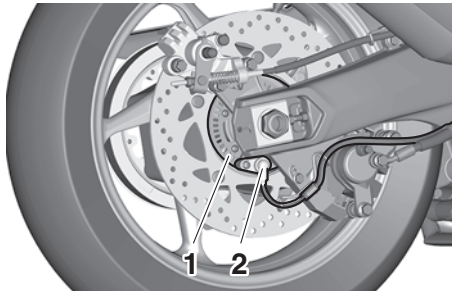

1. Rear wheel sensor rotor
2. Rear wheel sensor

Fuel tank cap

EAU77324

To access the fuel tank, open the fuel tank cap lid. (See page 3-11.)

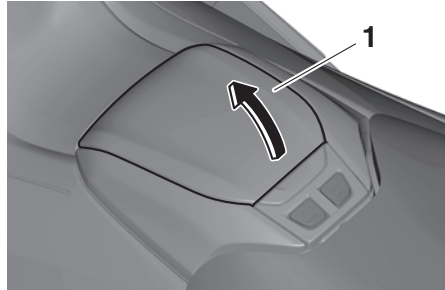

1. Fuel tank cap lid

To remove the fuel tank cap, press the lock release button and turn the fuel tank cap counterclockwise.

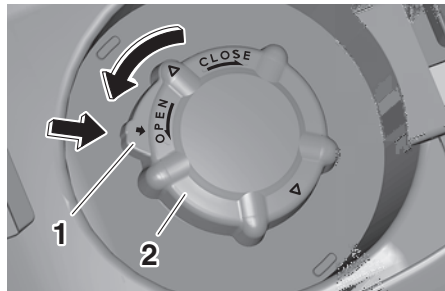

1. Lock release button
2. Fuel tank cap

To install the fuel tank cap, turn it clockwise until the lock release button pops out.

EWA11263

! WARNING

Make sure that the fuel tank cap is properly installed and locked in place before operating the vehicle. Leaking fuel is a fire hazard.

Fuel

Make sure there is sufficient gasoline in the tank.

EAU13222

EWA10882

WARNING

Gasoline and gasoline vapors are extremely flammable. To avoid fires and explosions and to reduce the risk of injury when refueling, follow these instructions.

1. Before refueling, turn off the engine and be sure that no one is sitting on the vehicle. Never refuel while smoking, or while in the vicinity of sparks, open flames, or other sources of ignition such as the pilot lights of water heaters and clothes dryers.
2. Do not overfill the fuel tank. When refueling, be sure to insert the pump nozzle into the fuel tank filler hole. Stop filling when the fuel reaches the bottom of the filler tube. Because fuel expands when it heats up, heat from the engine or the sun can cause fuel to spill out of the fuel tank.

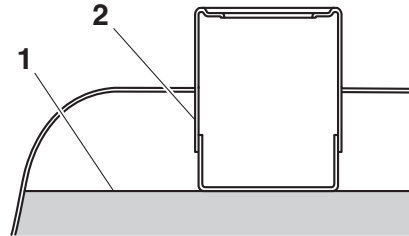

1. Maximum fuel level
2. Fuel tank filler tube
3. Wipe up any spilled fuel immediately. **NOTICE: Immediately wipe off spilled fuel with a clean, dry, soft cloth, since fuel may deteriorate painted surfaces or plastic parts.** [ECA10072]
4. Be sure to securely close the fuel tank cap.

EWA15152

WARNING

Gasoline is poisonous and can cause injury or death. Handle gasoline with care. Never siphon gasoline by mouth. If you should swallow some gasoline or inhale a lot of gasoline vapor, or get some gasoline in your eyes, see your doctor immedi-

ately. If gasoline spills on your skin, wash with soap and water. If gasoline spills on your clothing, change your clothes.

EAU86072

Your Yamaha engine was designed to use unleaded gasoline with a research octane number of 95 or higher. If engine knocking or pinging occurs, use a gasoline of a different brand or higher octane rating.

Recommended fuel:

Unleaded gasoline (E10 acceptable)

Octane number (RON):

95

Fuel tank capacity:

15 L (4.0 US gal, 3.3 Imp.gal)

Fuel tank reserve:

3.0 L (0.79 US gal, 0.66 Imp.gal)

Instrument and control functions

ECA11401

EAU80200



NOTICE

Use only unleaded gasoline. The use of leaded gasoline will cause severe damage to internal engine parts, such as the valves and piston rings, as well as to the exhaust system.

5

TIP

- This mark identifies the recommended fuel for this vehicle as specified by European regulation (EN228).
- Confirm the gasoline pump nozzle has the same fuel identification mark.

Gasohol

There are two types of gasohol: gasohol containing ethanol and that containing methanol. Gasohol containing ethanol can be used if the ethanol content does not exceed 10% (E10). Gasohol containing methanol is not recommended by Yamaha because it can cause damage to the fuel system or vehicle performance problems.

Fuel tank overflow hose

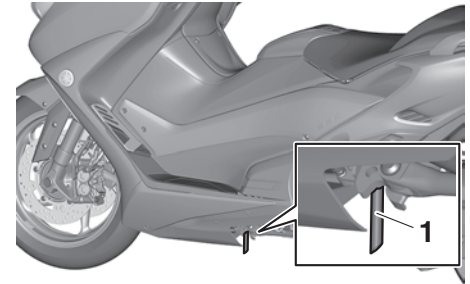

1. Fuel tank overflow hose

Before operating the vehicle:

- Check the fuel tank overflow hose connection.
- Check the fuel tank overflow hose for cracks or damage, and replace it if necessary.
- Make sure that the end of the fuel tank overflow hose is not blocked, and clean it if necessary.
- Make sure that the end of the fuel tank overflow hose is positioned as shown.

TIP

See page 8-12 for canister information.

Catalytic converter

EAU13435

The exhaust system contains catalytic converter(s) to reduce harmful exhaust emissions.

EWA10863

WARNING

The exhaust system is hot after operation. To prevent a fire hazard or burns:

- Do not park the vehicle near possible fire hazards such as grass or other materials that easily burn.
- Park the vehicle in a place where pedestrians or children are not likely to touch the hot exhaust system.
- Make sure that the exhaust system has cooled down before doing any maintenance work.
- Do not allow the engine to idle more than a few minutes. Long idling can cause a build-up of heat.

Storage compartments

EAU88751

Front storage compartment

To open the storage compartment, press the button.

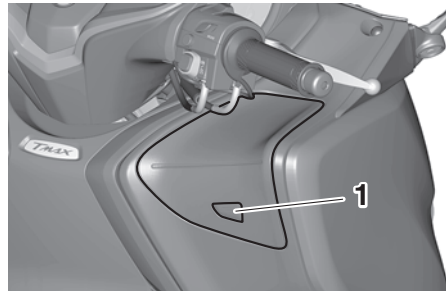

1. Button

Open the lid as shown.

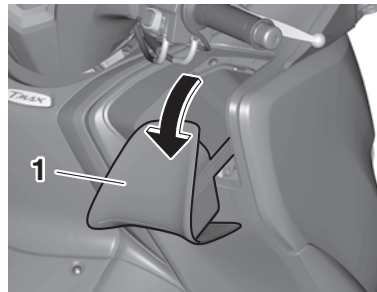

1. Lid

To close the storage compartment, push the lid into the original position.

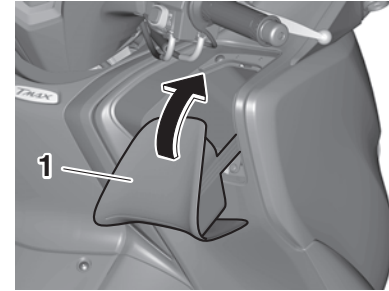

1. Lid

TIP

For XP560D: this compartment has an electronic lock. (See page 3-12.)

Rear storage compartment

This storage compartment was designed to hold one full-faced helmet or two 3/4-faced helmets. **NOTICE:** The shaded area is not a storage compartment. To prevent damaging the seat hinges, do not place any items in this area. [ECA16092]

Instrument and control functions

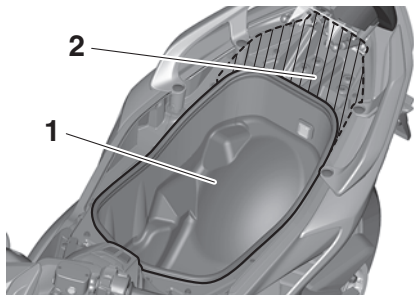

5

1. Rear storage compartment
2. Shaded area

TIP

- Some helmets cannot be stored in the rear storage compartment because of their size or shape.
- Do not leave the vehicle unattended with the seat open.
- Do not place the smart key inside a storage compartment. It may get locked inside and the smart key system not operate normally.

ECA15964

NOTICE

- Do not leave the seat open for an extended period of time, otherwise the light may cause the battery to discharge.

- Since the storage compartment may get wet when washing the vehicle, wrap any articles stored in the compartment in a plastic bag.
- To avoid humidity from spreading through the storage compartment and to discourage possible mold growth, wrap wet articles in a plastic bag before storing them in the compartment.
- Do not keep anything valuable or breakable in the storage compartment.
- Since the storage compartment accumulates heat from the engine and from direct sunlight, do not store anything susceptible to heat, such as food or flammable items, inside the compartment.

- Do not exceed the load limit of 5.0 kg (11 lb) for the rear storage compartment.
- Do not exceed the maximum load of 195 kg (430 lb) (XP560D) 197 kg (434 lb) (XP560E) for the vehicle.

EWA20960

WARNING

- Do not exceed the load limit of 1.0 kg (2 lb) for the front storage compartment.

Windshield (XP560E)

EAU81442

The windshield height can be changed to one of two positions.

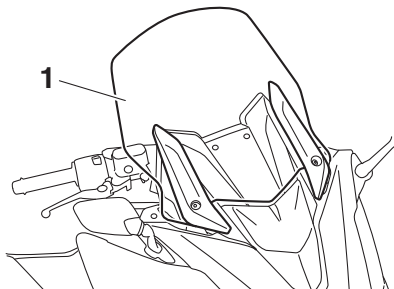

1. Windshield

To adjust the windshield height

1. Remove the screw access covers by removing the quick fasteners.

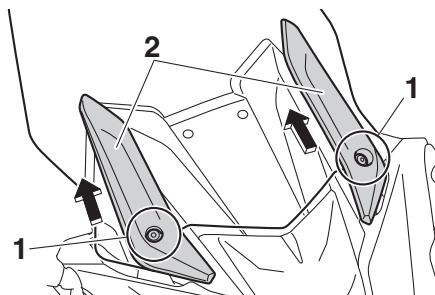

1. Quick fastener
2. Screw access cover

TIP

To remove the quick fastener, rotate its screwed portion counterclockwise with a hexagon wrench.

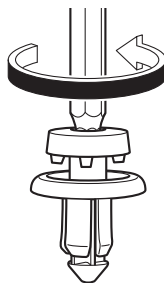

2. Remove the caps.

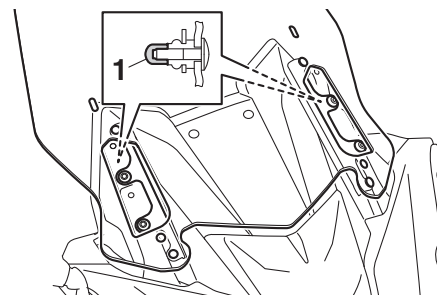

1. Cap

3. Remove the windshield by removing the screws.

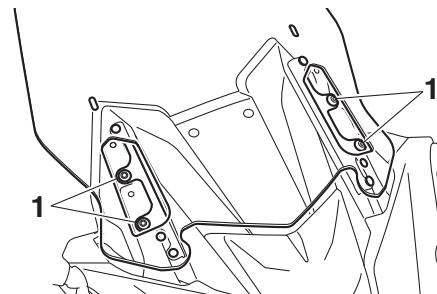

1. Screw

4. Install the windshield to the desired position by installing the screws.

Instrument and control functions

EAU39672

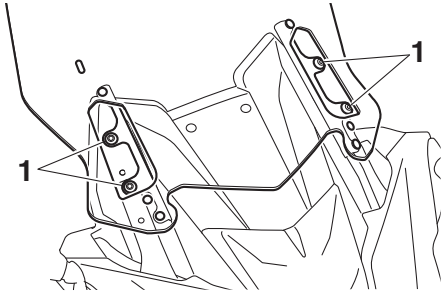

1. Screw

5. Tighten the screws to the specified torque. **WARNING! A loose windshield could cause an accident. Be sure to tighten the screws to the specified torque.**

[EWA15511]

Tightening torque:

Windshield screw:
10 N·m (1.0 kgf·m, 7.4 lb·ft)

6. Install the caps.
7. Place the screw access covers, and then install the quick fasteners.

TIP

To install the quick fastener, set it with its screwed portion pulled out from the surface of the quick fastener, and then push it down to the surface.

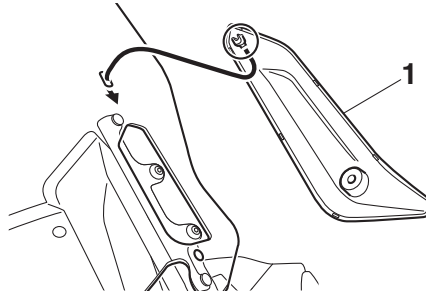

1. Screw access cover

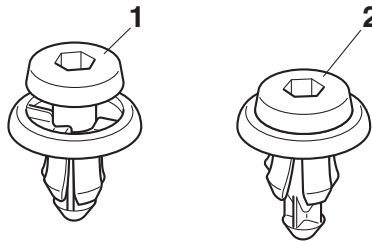

1. Quick fastener (before installation)
2. Quick fastener (after installation)

Rear view mirrors

The rear view mirrors of this vehicle can be folded forward or backward for parking in narrow spaces. Fold the mirrors back to their original position before riding.

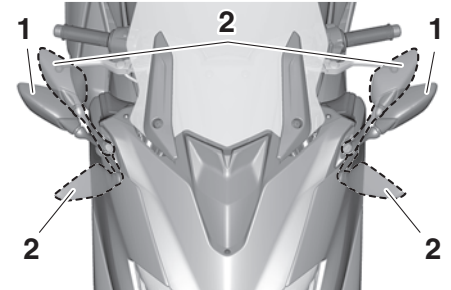

1. Riding position
2. Parking position

WARNING

Be sure to fold the rear view mirrors back to their original position before riding.

EWA14372

Shock absorber assembly

EAU77584

EWA10222

WARNING

This shock absorber assembly contains highly pressurized nitrogen gas. Read and understand the following information before handling the shock absorber assembly.

- Do not tamper with or attempt to open the cylinder assembly.
- Do not subject the shock absorber assembly to an open flame or other high heat source. This may cause the unit to explode due to excessive gas pressure.
- Do not deform or damage the cylinder in any way. Cylinder damage will result in poor damping performance.
- Do not dispose of a damaged or worn-out shock absorber assembly yourself. Take the shock absorber assembly to a Yamaha dealer for any service.

For XP560D:

This model is equipped with adjustable suspension. The spring preload and rebound damping force can be adjusted.

Spring preload

Turn the adjusting ring in direction (a) to increase the spring preload.

Turn the adjusting ring in direction (b) to decrease the spring preload.

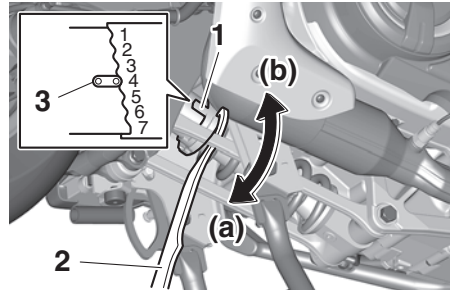

1. Spring preload adjusting ring
2. Special wrench
3. Position indicator

- Align the appropriate notch in the adjusting ring with the position indicator on the shock absorber.
- Use the special wrench included in the tool kit to make the adjustment.

Spring preload setting:

- Minimum (soft):
7 (XP560D)
- Standard:
4 (XP560D)
- Maximum (hard):
1 (XP560D)

Rebound damping force

Turn the adjusting screw in direction (a) to increase the rebound damping force.

Turn the adjusting screw in direction (b) to decrease the rebound damping force.

To set the rebound damping force, turn the adjuster in direction (a) until it stops, and then count the turns in direction (b).

Instrument and control functions

ECA10102

EAU77352

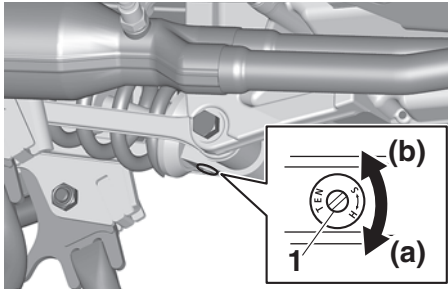

5

1. Rebound damping force adjusting screw

Rebound damping setting:

Minimum (soft):

3 (XP560D) turn(s) in direction (b)

Standard:

1.25 (XP560D) turn(s) in direction (b)

Maximum (hard):

0 (XP560D) turn(s) in direction (b)

TIP

When turning the damping force adjuster in direction (b), it may turn beyond the stated specifications, however such adjustments are ineffective and may damage the suspension.

NOTICE

To avoid damaging the mechanism, do not attempt to turn beyond the maximum or minimum settings.

Auxiliary DC jack

This model is equipped with a 12 V auxiliary DC jack. The DC jack is located inside the front storage compartment.

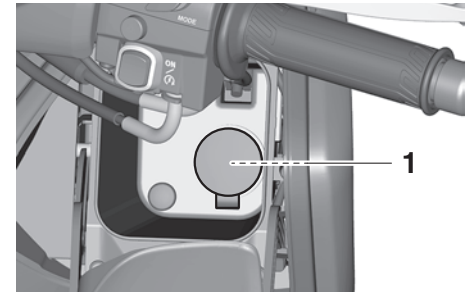

1. Auxiliary DC jack

ECA15432

NOTICE

The accessory connected to the auxiliary DC jack should not be used with the engine turned off, and the load must never exceed 24 W (2 A), otherwise the fuse may blow or the battery may discharge.

To use the auxiliary DC jack

1. Open the front storage compartment.

2. Turn the vehicle power off.
3. Remove the auxiliary DC jack cap.
4. Turn the accessory off.
5. Insert the accessory plug into the auxiliary DC jack.
6. Turn the vehicle power on and start the engine.
7. Turn the accessory on.

TIP

When finished with your ride, be sure to turn off the accessory, disconnect it, and then install the auxiliary DC jack cap.

EWA14361



To prevent electrical shock or short-circuiting, make sure that the cap is installed when the auxiliary DC jack is not being used.

EAU15306

Sidestand

The sidestand is located on the left side of the frame. Raise the sidestand or lower it with your foot while holding the vehicle upright.

TIP

The built-in sidestand switch is part of the ignition circuit cut-off system, which cuts the ignition in certain situations. (See the following section for an explanation of the ignition circuit cut-off system.)

EWA10242



The vehicle must not be ridden with the sidestand down, or if the sidestand cannot be properly moved up (or does not stay up), otherwise the sidestand could contact the ground and distract the operator, resulting in a possible loss of control. Yamaha's ignition circuit cut-off system has been designed to assist the operator in fulfilling the responsibility of raising the sidestand before starting off. Therefore, check

this system regularly and have a Yamaha dealer repair it if it does not function properly.

Instrument and control functions

EAU63612

Ignition circuit cut-off system

The ignition circuit cut-off system (comprising the sidestand switch and brake light switches) has the following functions.

- It prevents starting when the sidestand is up, but neither brake is applied.
- It prevents starting when either brake is applied, but the sidestand is still down.
- It cuts the running engine when the sidestand is moved down.

Periodically check the operation of the ignition circuit cut-off system according to the following procedure.

Instrument and control functions

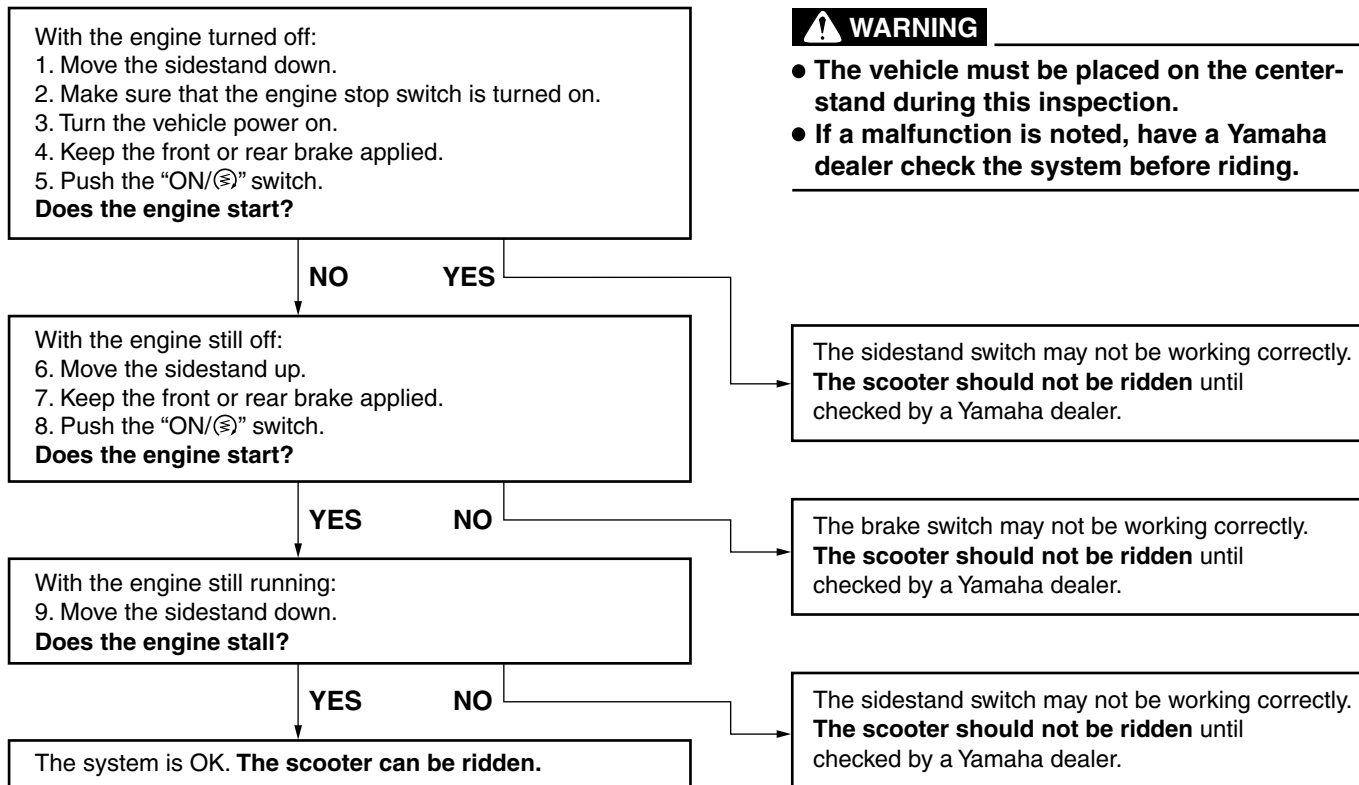

For your safety – pre-operation checks

EAU1559A

Inspect your vehicle each time you use it to make sure the vehicle is in safe operating condition. Always follow the inspection and maintenance procedures and schedules described in the Owner's Manual.

EWA11152

WARNING

Failure to inspect or maintain the vehicle properly increases the possibility of an accident or equipment damage. Do not operate the vehicle if you find any problem. If a problem cannot be corrected by the procedures provided in this manual, have the vehicle inspected by a Yamaha dealer.

Before using this vehicle, check the following points:

ITEM	CHECKS	PAGE
Fuel	<ul style="list-style-type: none">• Check fuel level in fuel tank.• Refuel if necessary.• Check fuel line for leakage.• Check fuel tank overflow hose for obstructions, cracks or damage, and check hose connection.	5-21, 5-22
Engine oil	<ul style="list-style-type: none">• Check oil level in engine.• If necessary, add recommended oil to specified level.• Check vehicle for oil leakage.	8-12
Coolant	<ul style="list-style-type: none">• Check coolant level in reservoir.• If necessary, add recommended coolant to specified level.• Check cooling system for leakage.	8-15
Front brake	<ul style="list-style-type: none">• Check operation.• If soft or spongy, have Yamaha dealer bleed hydraulic system.• Check brake pads for wear.• Replace if necessary.• Check fluid level in reservoir.• If necessary, add specified brake fluid to specified level.• Check hydraulic system for leakage.	8-22, 8-24, 8-24

6

For your safety – pre-operation checks

ITEM	CHECKS	PAGE
Rear brake	<ul style="list-style-type: none"> • Check operation. • If soft or spongy, have Yamaha dealer bleed hydraulic system. • Check brake pads for wear. • Replace if necessary. • Check fluid level in reservoir. • If necessary, add specified brake fluid to specified level. • Check hydraulic system for leakage. 	8-22, 8-24, 8-24
Throttle grip	<ul style="list-style-type: none"> • Make sure that operation is smooth. • Check throttle grip free play. • If necessary, have Yamaha dealer adjust throttle grip free play and lubricate cable and grip housing. 	8-18, 8-27
Wheels and tires	<ul style="list-style-type: none"> • Check for damage. • Check tire condition and tread depth. • Check air pressure. • Correct if necessary. 	8-19, 8-21
Brake levers	<ul style="list-style-type: none"> • Make sure that operation is smooth. • Lubricate lever pivoting points if necessary. 	8-27
Centerstand, sidestand	<ul style="list-style-type: none"> • Make sure that operation is smooth. • Lubricate pivots if necessary. 	8-28
Chassis fasteners	<ul style="list-style-type: none"> • Make sure that all nuts, bolts and screws are properly tightened. • Tighten if necessary. 	—
Instruments, lights, signals and switches	<ul style="list-style-type: none"> • Check operation. • Correct if necessary. 	—
Sidestand switch	<ul style="list-style-type: none"> • Check operation of ignition circuit cut-off system. • If system is not working correctly, have Yamaha dealer check vehicle. 	5-29
Drive belt	<ul style="list-style-type: none"> • Check belt condition. • Replace if damaged. 	8-26

Operation and important riding points

EAU15952

Read the Owner's Manual carefully to become familiar with all controls. If there is a control or function you do not understand, ask your Yamaha dealer.

EWA10272

WARNING

Failure to familiarize yourself with the controls can lead to loss of control, which could cause an accident or injury.

EAU16842

Engine break-in

There is never a more important period in the life of your engine than the period between 0 and 1600 km (1000 mi). For this reason, you should read the following material carefully.

Since the engine is brand new, do not put an excessive load on it for the first 1600 km (1000 mi). The various parts in the engine wear and polish themselves to the correct operating clearances. During this period, prolonged full-throttle operation or any condition that might result in engine overheating must be avoided.

EAU81480

0–1000 km (0–600 mi)

Avoid prolonged operation above 5100 r/min. **NOTICE: After 1000 km (600 mi) of operation, the engine oil must be changed, and the oil filter cartridge or element replaced.** [ECA11283]

1000–1600 km (600–1000 mi)

Avoid prolonged operation above 6100 r/min.

1600 km (1000 mi) and beyond

The vehicle can now be operated normally.

ECA25880

NOTICE

- **Keep the engine speed out of the high r/min zone.**
 - **If any engine trouble should occur during the engine break-in period, immediately have a Yamaha dealer check the vehicle.**
-

Starting the engine

The ignition circuit cut-off system will enable starting when the sidestand is be up.

To start the engine

1. With the smart key turned on, approach the vehicle.
2. Push the “ON/⊗” switch and set the engine stop switch to the run position.

Upon authentication of the smart key, the beeper will sound twice and the centerstand and steering locks (if applied) will be released.

3. Confirm the indicator and warning light(s) come on for a few seconds, and the go off. (See page 5-2.)

TIP

- Do not start the engine if the malfunction indicator light remains on.
- The ABS warning light should come on and stay on until the vehicle reaches a speed of 10 km/h (6 mi/h).

NOTICE

If a warning or indicator light does not work as described above, have a Yamaha dealer check the vehicle.

4. Close the throttle completely.
5. While applying the front or rear brake, push the “ON/⊗” switch.
6. Release the “ON/⊗” switch when the engine starts, or after 5 seconds. Wait 10 seconds before pressing the switch again to allow battery voltage to restore.

ECA11043

NOTICE

For maximum engine life, never accelerate hard when the engine is cold!

TIP

This model is equipped with:

- a lean angle sensor. This sensor stops the engine in case of a vehicle turnover. If this happens, the malfunction indicator light will come on, but this is not a malfunction. Turn the vehicle power off and then back on again to cancel the indicator light. Failing to do so will prevent the engine from starting even though the engine will crank when pushing the start switch.
- an engine auto-stop system. The engine stops automatically if left idling for 20 minutes. If the engine stops, simply push the start switch to restart the engine.

Operation and important riding points

Starting off

EAU45093

1. While pulling the rear brake lever with your left hand and holding the grab bar with your right hand, push the scooter off the center-stand.

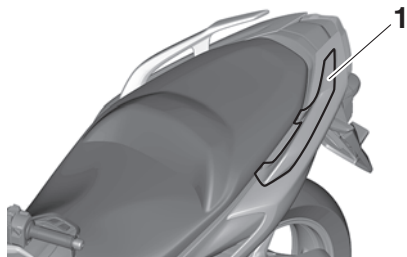

1. Grab bar

2. Sit astride the seat, and then adjust the rear view mirrors.
3. Switch the turn signals on.
4. Check for oncoming traffic, and then slowly turn the throttle grip (on the right) in order to take off.
5. Switch the turn signals off.

Acceleration and deceleration

EAU16782

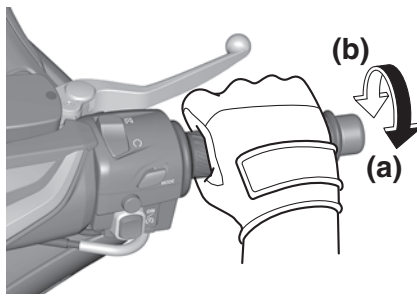

The speed can be adjusted by opening and closing the throttle. To increase the speed, turn the throttle grip in direction (a). To reduce the speed, turn the throttle grip in direction (b).

Braking

EAU60650

EWA17790

⚠ WARNING

- **Avoid braking hard or suddenly (especially when leaning over to one side), otherwise the vehicle may skid or overturn.**
- **Railroad crossings, streetcar rails, iron plates on road construction sites, and manhole covers become extremely slippery when wet. Therefore, slow down when approaching such areas and cross them with caution.**
- **Keep in mind that braking on a wet road is much more difficult.**
- **Ride slowly down a hill, as braking downhill can be very difficult.**

1. Close the throttle completely.
2. Apply both front and rear brakes simultaneously while gradually increasing the pressure.

Front

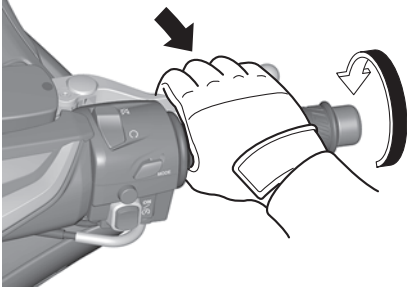

Rear

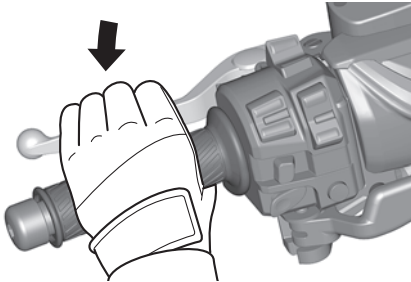

Tips for reducing fuel consumption

EAU16821

Fuel consumption depends largely on your riding style. Consider the following tips to reduce fuel consumption:

- Avoid high engine speeds during acceleration.
- Avoid high engine speeds with no load on the engine.
- Turn the engine off instead of letting it idle for an extended length of time (e.g., in traffic jams, at traffic lights or at railroad crossings).

Parking

EAU77962

When parking, turn the vehicle power off and then turn the smart key off.

If the sidestand is lowered when the engine is running, the engine will stop and the beeper will sound to prevent you from forgetting to turn off the vehicle power. To stop the beeper, turn the vehicle power off or raise the sidestand.

When leaving the vehicle, make sure you apply the steering lock and centerstand lock. Take the smart key with you.



Operation and important riding points

TIP

- After parking, if the smart key is not turned off and is within operating range, other people may be able to start the engine and operate the vehicle.
- The sidestand alarm beeper can be set to not activate. Contact your Yamaha dealer.

- Do not park on a slope or on soft ground, otherwise the vehicle may overturn, increasing the risk of a fuel leak and fire.
 - Do not park near grass or other flammable materials which might catch fire.
-

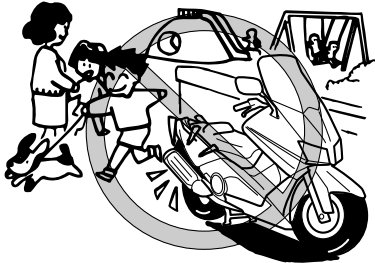

7

EWA10312

WARNING

- Since the engine and exhaust system can become very hot, park in a place where pedestrians or children are not likely to touch them and be burned.

EAU17246

EWA15123

EAU17303

Periodic inspection, adjustment, and lubrication will keep your vehicle in the safest and most efficient condition possible. Safety is an obligation of the vehicle owner/operator. The most important points of vehicle inspection, adjustment, and lubrication are explained on the following pages.

The intervals given in the periodic maintenance charts should be simply considered as a general guide under normal riding conditions. However, depending on the weather, terrain, geographical location, and individual use, the maintenance intervals may need to be shortened.

EWA10322

EWA15461

WARNING

Failure to properly maintain the vehicle or performing maintenance activities incorrectly may increase your risk of injury or death during service or while using the vehicle. If you are not familiar with vehicle service, have a Yamaha dealer perform service.

WARNING

Turn off the engine when performing maintenance unless otherwise specified.

- **A running engine has moving parts that can catch on body parts or clothing and electrical parts that can cause shocks or fires.**
- **Running the engine while servicing can lead to eye injury, burns, fire, or carbon monoxide poisoning – possibly leading to death. See page 1-3 for more information about carbon monoxide.**

WARNING

Brake discs, calipers, drums, and linings can become very hot during use. To avoid possible burns, let brake components cool before touching them.

Emission controls not only function to ensure cleaner air, but are also vital to proper engine operation and maximum performance. In the following periodic maintenance charts, the services related to emissions control are grouped separately. These services require specialized data, knowledge, and equipment. Maintenance, replacement, or repair of the emission control devices and systems may be performed by any repair establishment or individual that is certified (if applicable). Yamaha dealers are trained and equipped to perform these particular services.

Periodic maintenance and adjustment

EAU85230

Tool kit

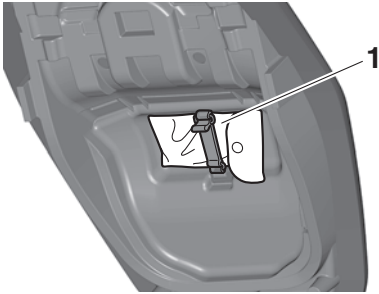

1. Tool kit

The tool kit is in the location shown. The information included in this manual and the tools provided in the tool kit are intended to assist you in the performance of preventive maintenance and minor repairs. However, a torque wrench and other tools are necessary to perform certain maintenance work correctly.

TIP _____

If you do not have the tools or experience required for a particular job, have your Yamaha dealer perform it for you.

Periodic maintenance and adjustment

EAU71033

Periodic maintenance charts

TIP

- Items marked with an asterisk should be performed by your Yamaha dealer because these items require special tools, data, and technical skills.
- From 50000 km (30000 mi), repeat the maintenance intervals starting from 10000 km (6000 mi).
- **The annual checks must be performed every year, except if a distance-based maintenance is performed instead.**

EAU71051

Periodic maintenance chart for the emission control system

NO.	ITEM	CHECK OR MAINTENANCE JOB	ODOMETER READING					ANNUAL CHECK
			1000 km (600 mi)	10000 km (6000 mi)	20000 km (12000 mi)	30000 km (18000 mi)	40000 km (24000 mi)	
1	* Fuel line	<ul style="list-style-type: none"> • Check fuel hoses for cracks or damage. • Replace if necessary. 		√	√	√	√	√
2	* Spark plugs	<ul style="list-style-type: none"> • Check condition. • Adjust gap and clean. 		√		√		
		<ul style="list-style-type: none"> • Replace. 			√		√	
3	* Valve clearance	<ul style="list-style-type: none"> • Check and adjust. 	Every 40000 km (24000 mi)					
4	* Fuel injection	<ul style="list-style-type: none"> • Check engine idle speed. 	√	√	√	√	√	√
		<ul style="list-style-type: none"> • Check and adjust synchronization. 		√	√	√	√	√
5	* Exhaust system	<ul style="list-style-type: none"> • Check for leakage. • Tighten if necessary. • Replace gaskets if necessary. 	√	√	√	√	√	

Periodic maintenance and adjustment

NO.	ITEM	CHECK OR MAINTENANCE JOB	ODOMETER READING					ANNUAL CHECK
			1000 km (600 mi)	10000 km (6000 mi)	20000 km (12000 mi)	30000 km (18000 mi)	40000 km (24000 mi)	
6	*	Evaporative emission control system			√		√	

Periodic maintenance and adjustment

EAU71353

General maintenance and lubrication chart

NO.	ITEM	CHECK OR MAINTENANCE JOB	ODOMETER READING					ANNUAL CHECK
			1000 km (600 mi)	10000 km (6000 mi)	20000 km (12000 mi)	30000 km (18000 mi)	40000 km (24000 mi)	
1	* Diagnostic system check	<ul style="list-style-type: none"> Perform dynamic inspection using Yamaha diagnostic tool. Check the error codes. 	√	√	√	√	√	√
2	* Air filter element	<ul style="list-style-type: none"> Replace. 			√		√	
3	* Air filter case check hose	<ul style="list-style-type: none"> Clean. 	√	√	√	√	√	
4	* V-belt case air filter elements	<ul style="list-style-type: none"> Clean. 		√		√		
		<ul style="list-style-type: none"> Replace. 			√		√	
5	* Front brake	<ul style="list-style-type: none"> Check operation, fluid level, and for fluid leakage. Replace brake pads if necessary. 	√	√	√	√	√	√
6	* Rear brake	<ul style="list-style-type: none"> Check operation, fluid level, and for fluid leakage. Replace brake pads if necessary. 	√	√	√	√	√	√
7	* Brake hoses	<ul style="list-style-type: none"> Check for cracks or damage. 		√	√	√	√	√
		<ul style="list-style-type: none"> Replace. 	Every 4 years					
8	* Brake fluid	<ul style="list-style-type: none"> Change. 	Every 2 years					
9	Rear brake lock cable	<ul style="list-style-type: none"> Check cable length. Adjust if necessary. 	At the initial interval and 4000 km (2400 mi) after the initial 1000 km (600 mi) and every 5000 km (3000 mi) thereafter.					
10	* Rear brake lock	<ul style="list-style-type: none"> Check operation. Adjust. 	√	√	√	√	√	√
11	* Wheels	<ul style="list-style-type: none"> Check runout and for damage. Replace if necessary. 		√	√	√	√	

Periodic maintenance and adjustment

NO.	ITEM	CHECK OR MAINTENANCE JOB	ODOMETER READING					ANNUAL CHECK
			1000 km (600 mi)	10000 km (6000 mi)	20000 km (12000 mi)	30000 km (18000 mi)	40000 km (24000 mi)	
12 *	Tires	<ul style="list-style-type: none"> • Check tread depth and for damage. • Replace if necessary. • Check air pressure. • Correct if necessary. 		√	√	√	√	√
13 *	Wheel bearings	<ul style="list-style-type: none"> • Check bearing for looseness or damage. 		√	√	√	√	
14 *	Drive belt	<ul style="list-style-type: none"> • Check belt condition. • Replace if damaged. • Check belt tension. • Adjust if necessary. 	At the initial interval and every 10000 km (6000 mi) until 40000 km (24000 mi), and every 5000 km (3000 mi) thereafter.					
15 *	Drive pulley and drive axle	<ul style="list-style-type: none"> • Lubricate. 			√		√	
16 *	Steering bearings	<ul style="list-style-type: none"> • Check bearing assemblies for looseness. 	√	√		√		
		<ul style="list-style-type: none"> • Moderately repack with lithium-soap-based grease. 			√		√	
17 *	Chassis fasteners	<ul style="list-style-type: none"> • Make sure that all nuts, bolts and screws are properly tightened. 		√	√	√	√	√
18	Front and rear brake lever pivot shaft	<ul style="list-style-type: none"> • Lubricate with silicone grease. 		√	√	√	√	√
19 *	Sidestand, center-stand	<ul style="list-style-type: none"> • Check operation. • Lubricate with lithium-soap-based grease. 		√	√	√	√	√
20 *	Sidestand switch	<ul style="list-style-type: none"> • Check operation and replace if necessary. 	√	√	√	√	√	√

Periodic maintenance and adjustment

NO.	ITEM	CHECK OR MAINTENANCE JOB	ODOMETER READING					ANNUAL CHECK
			1000 km (600 mi)	10000 km (6000 mi)	20000 km (12000 mi)	30000 km (18000 mi)	40000 km (24000 mi)	
21	* Front fork	<ul style="list-style-type: none"> • Check operation and for oil leakage. • Replace if necessary. 		√	√	√	√	
22	* Shock absorber assembly	<ul style="list-style-type: none"> • Check operation and for oil leakage. • Replace if necessary. 		√	√	√	√	
23	* Rear suspension relay arm and connecting arm pivoting points	<ul style="list-style-type: none"> • Check operation. 		√	√	√	√	
24	Engine oil	<ul style="list-style-type: none"> • Change (warm engine before draining). • Check oil level and vehicle for oil leakage. 	At the initial interval and when the oil change indicator flashes or comes on.					√
25	Engine oil filter cartridge	<ul style="list-style-type: none"> • Replace. 	√		√		√	
26	* Cooling system	<ul style="list-style-type: none"> • Check coolant level and vehicle for coolant leakage. 		√	√	√	√	√
		<ul style="list-style-type: none"> • Change. 	Every 3 years					
27	* V-belt	<ul style="list-style-type: none"> • Replace. 	When the V-belt replacement indicator flashes [every 20000 km (12000 mi)]					
28	* Front and rear brake switches	<ul style="list-style-type: none"> • Check operation. 	√	√	√	√	√	√
29	* Moving parts and cables	<ul style="list-style-type: none"> • Lubricate. 		√	√	√	√	√

Periodic maintenance and adjustment

NO.	ITEM	CHECK OR MAINTENANCE JOB	ODOMETER READING					ANNUAL CHECK
			1000 km (600 mi)	10000 km (6000 mi)	20000 km (12000 mi)	30000 km (18000 mi)	40000 km (24000 mi)	
30	* Throttle grip housing and cable	<ul style="list-style-type: none"> • Check operation and free play. • Adjust the throttle cable free play if necessary. • Lubricate the throttle grip housing and cable. 		√	√	√	√	√
31	* Lights, signals and switches	<ul style="list-style-type: none"> • Check operation. • Adjust headlight beam. 	√	√	√	√	√	√

EAU72781

TIP

Air filters

- The engine air filter uses a disposable oil-coated paper element. This element cannot be cleaned with compressed air, doing so will only damage it.
- If you often ride in the rain or in dusty areas, have the engine air filter and V-belt air filter elements serviced more frequently.

Hydraulic brake service

- Regularly check the brake fluid levels in the reservoirs, and refill as necessary.
- Replace the internal components of the brake master cylinders and calipers, and change the brake fluid every 2 years.
- Replace the brake hoses every 4 years, or sooner if cracked or damaged.

Removing and installing panels

EAU18773

The panels shown need to be removed to perform some of the maintenance jobs described in this chapter. Refer to this section each time a panel needs to be removed and installed.

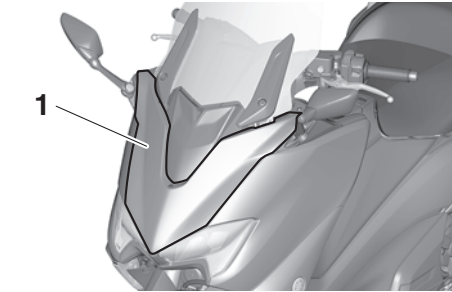

1. Panel A

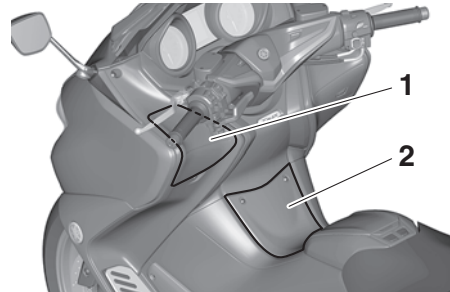

1. Panel B
2. Panel C

Panel A

To remove the panel

1. Remove the screws.

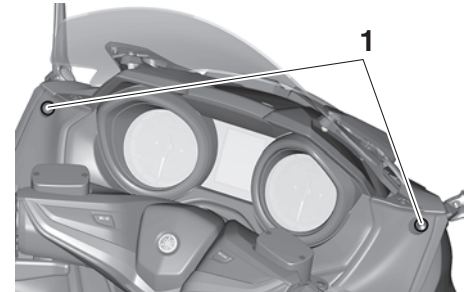

1. Screw

EAU77482

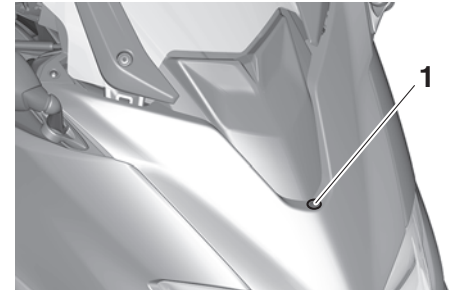

1. Screw

2. Release the sides of the panel by pulling its upper left and right sides to unhook them as shown.

Periodic maintenance and adjustment

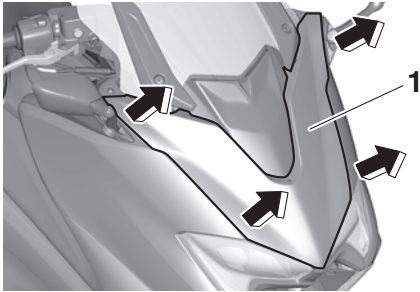

1. Panel A

3. Remove the panel as shown.

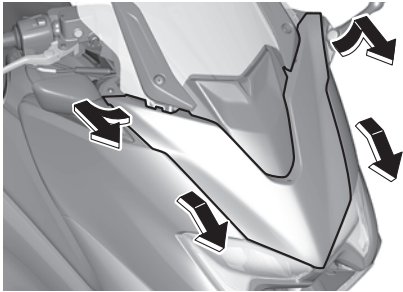

To install the panel

1. Insert the tabs on the upper left and right sides of the panel.
2. Align the center and lower projections and then push the panel into its original position.

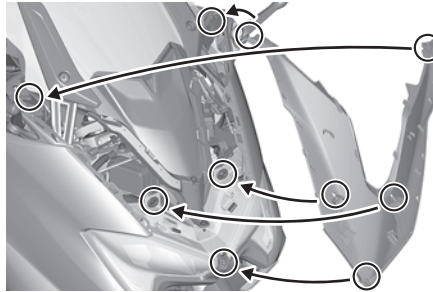

3. Install the screws.

Panel B

To remove the panel

1. Remove the screw.

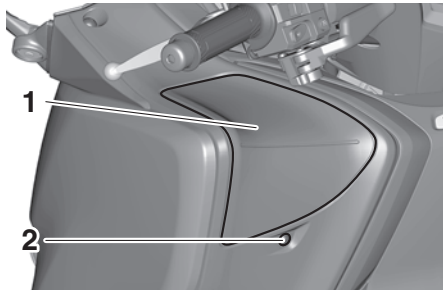

1. Panel B
2. Screw

2. Gently pry up the upper portion of the panel, and then slide the panel upwards.

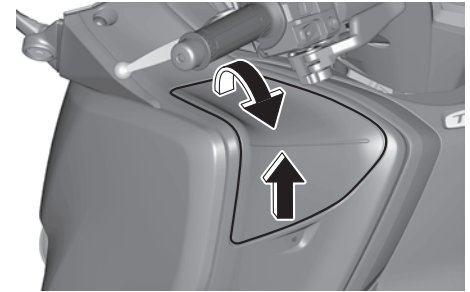

To install the panel

Place the panel in the original position, and then install the screw.

Panel C

To remove the panel

Remove the screws, and then pull the panel outward.

Periodic maintenance and adjustment

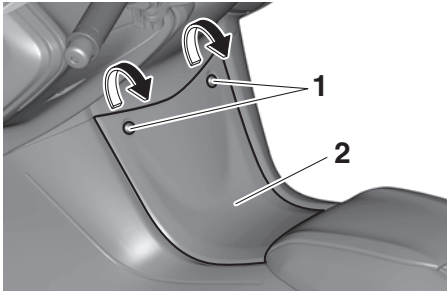

1. Screw
2. Panel C

To install the panel

Place the panel in the original position, and then install the screws.

Checking the spark plugs

EAU19643

The spark plugs are important engine components, which should be checked periodically, preferably by a Yamaha dealer. Since heat and deposits will cause any spark plug to slowly erode, they should be removed and checked in accordance with the periodic maintenance and lubrication chart. In addition, the condition of the spark plugs can reveal the condition of the engine.

The porcelain insulator around the center electrode of each spark plug should be a medium-to-light tan (the ideal color when the vehicle is ridden normally), and all spark plugs installed in the engine should have the same color. If any spark plug shows a distinctly different color, the engine could be operating improperly. Do not attempt to diagnose such problems yourself. Instead, have a Yamaha dealer check the vehicle.

If a spark plug shows signs of electrode erosion and excessive carbon or other deposits, it should be replaced.

Specified spark plug:
NGK/LMAR7G

Before installing a spark plug, the spark plug gap should be measured with a wire thickness gauge and, if necessary, adjusted to specification.

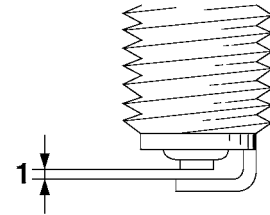

1. Spark plug gap

Spark plug gap:
0.7–0.8 mm (0.028–0.031 in)

Clean the surface of the spark plug gasket and its mating surface, and then wipe off any grime from the spark plug threads.

Tightening torque:
Spark plug:
13 N·m (1.3 kgf·m, 9.6 lb·ft)

Periodic maintenance and adjustment

TIP

If a torque wrench is not available when installing a spark plug, a good estimate of the correct torque is 1/4–1/2 turn past finger tight. However, the spark plug should be tightened to the specified torque as soon as possible.

Canister

EAU36112

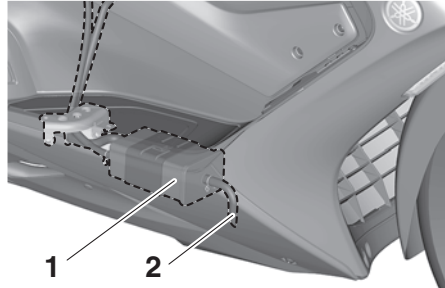

1. Canister
2. Canister breather

This model is equipped with a canister to prevent the discharging of fuel vapor into the atmosphere. Before operating this vehicle, make sure to check the following:

- Check each hose connection.
- Check each hose and canister for cracks or damage. Replace if damaged.
- Make sure that the canister breather is not blocked, and if necessary, clean it.

EAU77364

Engine oil and oil filter cartridge

The engine oil level should be checked before each ride. In addition, the oil must be changed and the oil filter cartridge replaced at the intervals specified in the periodic maintenance and lubrication chart.

To check the engine oil level

1. Place the vehicle on the centerstand. A slight tilt to the side can result in a false reading.
2. Start the engine, warm it up for two minutes, and then turn it off.
3. Wait two minutes until the oil level settles.
4. Check the oil level through the check window located at the bottom-left side of the crankcase.

TIP

The engine oil should be between the minimum and maximum level marks.

Periodic maintenance and adjustment

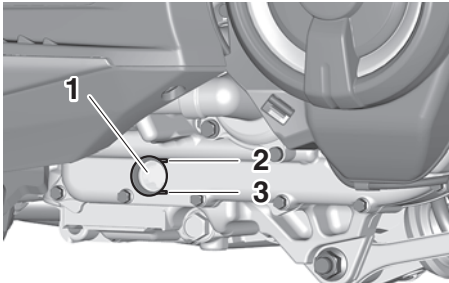

1. Engine oil level check window
2. Maximum level mark
3. Minimum level mark

5. If the engine oil is below the minimum level mark, add sufficient oil of the recommended type to raise it to the correct level.

To change the engine oil (and replace the oil filter cartridge)

1. Place the vehicle on a level surface.
2. Start the engine, warm it up for several minutes, and then turn it off.
3. Place an oil pan under the engine to collect the used oil.

4. Remove the engine oil filler cap, and then the engine oil drain bolt and its gasket.

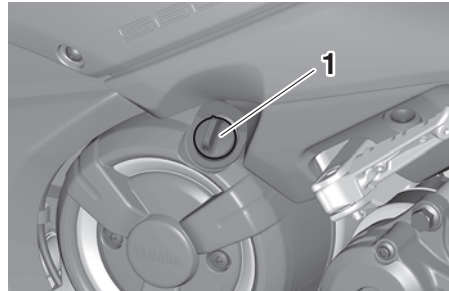

1. Engine oil filler cap

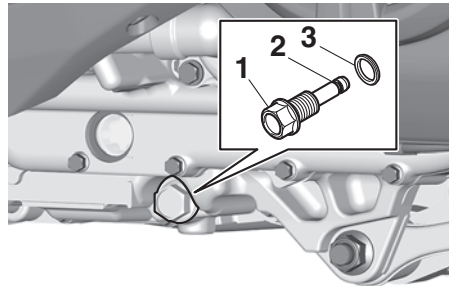

1. Engine oil drain bolt
2. O-ring
3. Gasket

5. Check the O-ring for damage and replace it if necessary.

TIP

Skip steps 6–8 if the oil filter cartridge is not being replaced.

6. Remove the oil filter cartridge with an oil filter wrench.

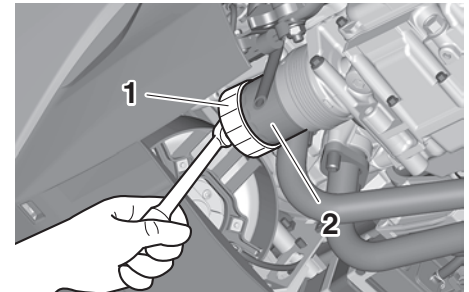

1. Oil filter wrench
2. Oil filter cartridge

TIP

An oil filter wrench is available at a Yamaha dealer.

7. Apply a thin coat of clean engine oil to the O-ring of the new oil filter cartridge.

Periodic maintenance and adjustment

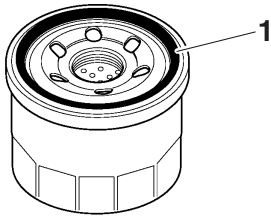

1. O-ring

TIP

Make sure that the O-ring is properly seated.

8. Install the new oil filter cartridge, and then tighten it to the specified torque with a torque wrench.

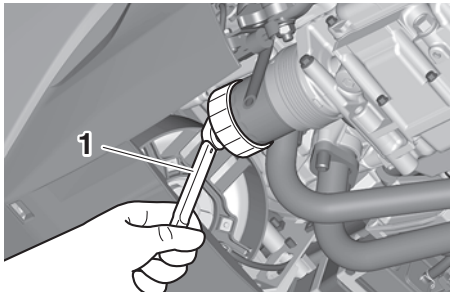

1. Torque wrench

Tightening torque:

Oil filter cartridge:
17 N·m (1.7 kgf·m, 13 lb·ft)

9. Install the engine oil drain bolt and its new gasket, and then tighten the bolt to the specified torque.

Tightening torque:

Engine oil drain bolt:
43 N·m (4.3 kgf·m, 32 lb·ft)

10. Check the O-ring for damage and replace it if necessary.

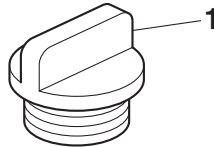

1. Engine oil filler cap
2. O-ring

11. Refill with the specified amount of the recommended engine oil, and then install and tighten the oil filler cap.

Engine oil:

Recommended brand:

YAMALUBE

SAE viscosity grades:

10W-40

Recommended engine oil grade:

API service SG type or higher,

JASO standard MA

Oil quantity:

Oil change:

2.60 L (2.75 US qt, 2.29 Imp.qt)

With oil filter removal:

2.90 L (3.07 US qt, 2.55 Imp.qt)

TIP

Be sure to wipe off spilled oil on any parts after the engine and exhaust system have cooled down.

ECA11621

NOTICE

- In order to prevent clutch slippage (since the engine oil also lubricates the clutch), do not mix any chemical additives. Do not use oils with a diesel specification of "CD" or oils of a higher quality than specified. In addition, do not use oils labeled "ENERGY CONSERVING II" or higher.

● **Make sure that no foreign material enters the crankcase.**

12. Start the engine, and then let it idle for several minutes while checking it for oil leakage. If oil is leaking, immediately turn the engine off and check for the cause.
13. Turn the engine off, and then check the oil level and correct it if necessary.
14. Reset the oil change indicator. (See page 5-11.)

Why Yamalube

YAMALUBE oil is a Genuine YAMAHA Part born of the engineers' passion and belief that engine oil is an important liquid engine component. We form teams of specialists in the fields of mechanical engineering, chemistry, electronics and track testing, and have them develop the engine together with the oil it will use. Yamalube oils take full advantage of the base oil's qualities and blend in the ideal balance of additives to make sure the final oil clears our performance standards. Thus, Yamalube mineral, semisynthetic and synthetic oils have their own distinct characters and value. Yamaha's experience gained over many years of research and development into oil since the 1960's helps make Yamalube the best choice for your Yamaha engine.



EAU85450

Coolant

The coolant level should be checked regularly. In addition, the coolant must be changed at the intervals specified in the periodic maintenance chart.

Recommended coolant:

YAMALUBE coolant

Coolant quantity:

Coolant reservoir (max level mark):
0.25 L (0.26 US qt, 0.22 Imp.qt)
Radiator (including all routes):
1.54 L (1.63 US qt, 1.36 Imp.qt)

EAU51203

TIP

If genuine Yamaha coolant is not available, use an ethylene glycol antifreeze containing corrosion inhibitors for aluminum engines and mix with distilled water at a 1:1 ratio.

8

To check the coolant level

Since the coolant level varies with engine temperature, check when the engine is cold.

1. Park the vehicle on a level surface.
2. Hold the vehicle upright, or place it on the centerstand.

EAU52025

Periodic maintenance and adjustment

3. Look at the coolant level through the check window.

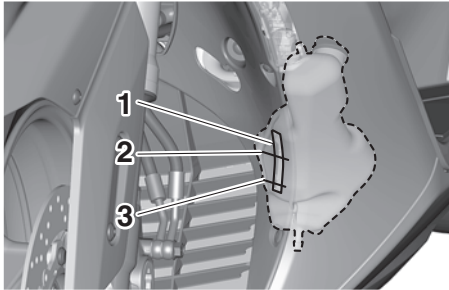

1. Coolant level check window
2. Maximum level mark
3. Minimum level mark

4. If the coolant is at or below the minimum level mark, remove the left floorboard mat by pulling it up.

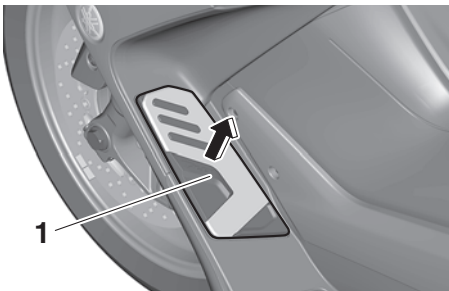

1. Floorboard mat

5. Remove the coolant reservoir cover by removing the screws.

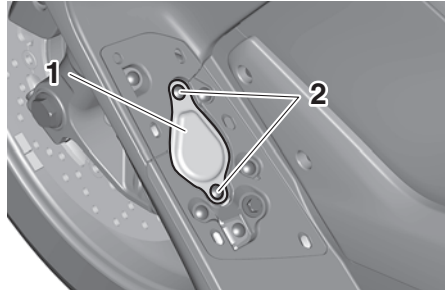

1. Coolant reservoir cover
2. Screw

6. Remove the coolant reservoir cap. **WARNING! Remove only the coolant reservoir cap. Never attempt to remove the radiator cap when the engine is hot.**

[EWA15162]

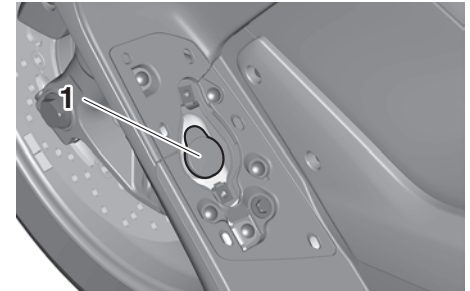

1. Coolant reservoir cap

7. Add coolant to the maximum level mark. **NOTICE: If coolant is not available, use distilled water or soft tap water instead. Do not use hard water or salt water since it is harmful to the engine. If water has been used instead of coolant, replace it with coolant as soon as possible, otherwise the cooling system will not be protected against frost and corrosion. If water has been added to the coolant, have a Yamaha dealer check the anti-freeze content of the coolant as soon as possible, otherwise the effectiveness of the coolant will be reduced.** [ECA10473]

Periodic maintenance and adjustment

8. Install the coolant reservoir cap.
9. Install the coolant reservoir cover.
10. Install the floorboard mat.

Changing the coolant

EAU33032

The coolant must be changed at the intervals specified in the periodic maintenance and lubrication chart. Have a Yamaha dealer change the coolant.

WARNING! Never attempt to remove the radiator cap when the engine is hot. [EWA10382]

Replacing the engine air filter element and cleaning the check hose

EAU88800

The engine air filter element should be replaced at the intervals specified in the periodic maintenance chart. Replace the air filter element more frequently if you often ride in wet or dusty conditions.

In addition, the air filter check hose must be checked and cleaned by a Yamaha dealer at the intervals specified in the periodic maintenance and lubrication chart.

To replace the air filter element

1. Remove panel C. (See page 8-9.)
2. Remove the air filter case cover by removing the screws.

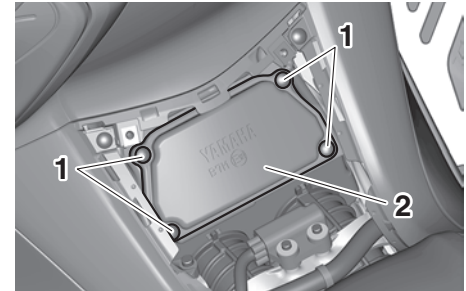

1. Screw
2. Air filter case cover

3. Pull the air filter element out.

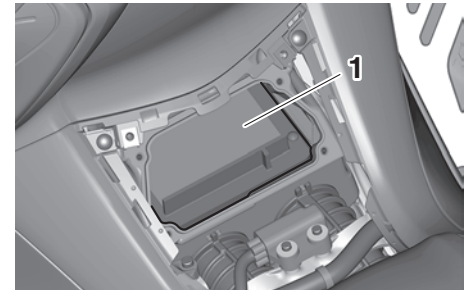

1. Air filter element

4. Insert a new air filter element into the air filter case. **NOTICE: Make sure that the air filter element is properly seated in the air filter case. The engine should never**

Periodic maintenance and adjustment

be operated without the air filter element installed, otherwise the piston(s) and/or cylinder(s) may become excessively worn.

[ECA10482]

5. Install the air filter case cover by installing the screws.
6. Install the panel.

Checking the engine idling speed

EAU44735

Check the engine idling speed and, if necessary, have it corrected by a Yamaha dealer.

Engine idling speed:
1100–1300 r/min

Checking the throttle grip free play

EAU21386

Measure the throttle grip free play as shown.

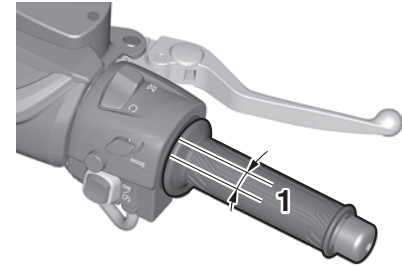

1. Throttle grip free play

Throttle grip free play:
1.0–3.0 mm (0.04–0.12 in)

Periodically check the throttle grip free play and, if necessary, have a Yamaha dealer adjust it.

EAU21403

Valve clearance

The valves are an important engine component, and since valve clearance changes with use, they must be checked and adjusted at the intervals specified in the periodic maintenance chart. Unadjusted valves can result in improper air-fuel mixture, engine noise, and eventually engine damage. To prevent this from occurring, have your Yamaha dealer check and adjust the valve clearance at regular intervals.

TIP

This service must be performed when the engine is cold.

EAU77621

Tires

Tires are the only contact between the vehicle and the road. Safety in all conditions of riding depends on a relatively small area of road contact. Therefore, it is essential to maintain the tires in good condition at all times and replace them at the appropriate time with the specified tires.

Tire air pressure

The tire air pressure should be checked and, if necessary, adjusted before each ride.

EWA10504

WARNING

Operation of this vehicle with improper tire pressure may cause severe injury or death from loss of control.

- The tire air pressure must be checked and adjusted on cold tires (i.e., when the temperature of the tires equals the ambient temperature).
- The tire air pressure must be adjusted in accordance with the riding speed and with the total

weight of rider, passenger, cargo, and accessories approved for this model.

Cold tire air pressure:

1 person:

Front:

225 kPa (2.25 kgf/cm², 33 psi)

Rear:

250 kPa (2.50 kgf/cm², 36 psi)

2 persons:

Front:

225 kPa (2.25 kgf/cm², 33 psi)

Rear:

280 kPa (2.80 kgf/cm², 41 psi)

Maximum load:

Vehicle:

195 kg (430 lb) (XP560D)

197 kg (434 lb) (XP560E)

The vehicle's maximum load is the combined weight of the rider, passenger, cargo, and any accessories.

EWA10512

WARNING

Never overload your vehicle. Operation of an overloaded vehicle could cause an accident.

Periodic maintenance and adjustment

Tire inspection

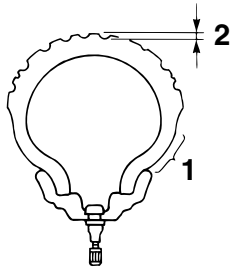

1. Tire sidewall
2. Tire tread depth

The tires must be checked before each ride. If the center tread depth reaches the specified limit, if the tire has a nail or glass fragments in it, or if the sidewall is cracked, have a Yamaha dealer replace the tire immediately.

Minimum tire tread depth (front and rear):
1.6 mm (0.06 in)

TIP

The tire tread depth limits may differ from country to country. Always comply with the local regulations.

EWA10472

WARNING

- Have a Yamaha dealer replace excessively worn tires. Besides being illegal, operating the vehicle with excessively worn tires decreases riding stability and can lead to loss of control.
- The replacement of all wheel and brake-related parts, including the tires, should be left to a Yamaha dealer, who has the necessary professional knowledge and experience to do so.
- Ride at moderate speeds after changing a tire since the tire surface must first be “broken in” for it to develop its optimal characteristics.

Tire information

This model is equipped with tubeless tires and tire air valves.

Tires age, even if they have not been used or have only been used occasionally. Cracking of the tread and sidewall rubber, sometimes accompanied by carcass deformation, is an evidence of

ageing. Old and aged tires shall be checked by tire specialists to ascertain their suitability for further use.

EWA16101

WARNING

- The front and rear tires should be of the same make and design, otherwise the handling characteristics of the vehicle may be different, which could lead to an accident.
- Always make sure that the valve caps are securely installed to prevent air pressure leakage.
- Use only the tire valves and valve cores listed below to avoid tire deflation during a ride.

After extensive tests, only the tires listed below have been approved for this model by Yamaha.

EAU51921

Front tire:

Size:

120/70R15M/C 56H

Manufacturer/model:

BRIDGESTONE/BATTLAX SCF

Tire air valve:

PVR59A

Valve core:

#9100 (original)

Rear tire:

Size:

160/60R15M/C 67H

Manufacturer/model:

BRIDGESTONE/BATTLAX SCR

Tire air valve:

TR412

Valve core:

#9100 (original)

Cast wheels

To maximize the performance, durability, and safe operation of your vehicle, note the following points regarding the specified wheels.

- The wheel rims should be checked for cracks, bends, warpage or other damage before each ride. If any damage is found, have a Yamaha dealer replace the wheel. Do not attempt even the smallest repair to the wheel. A deformed or cracked wheel must be replaced.
- The wheel should be balanced whenever either the tire or wheel has been changed or replaced. An unbalanced wheel can result in poor performance, adverse handling characteristics, and a shortened tire life.
- After repairing or replacing the front tire, tighten the valve stem nut and locknut to the specified torques.

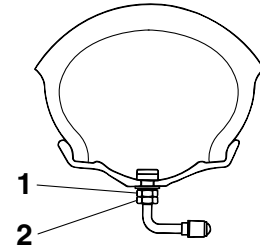

1. Valve stem nut
2. Valve stem locknut

Tightening torques:

Valve stem nut:

2.0 N·m (0.20 kgf·m, 1.5 lb·ft)

Valve stem locknut:

3.0 N·m (0.30 kgf·m, 2.2 lb·ft)

Periodic maintenance and adjustment

Checking the front and rear brake lever free play

EAU50861

Front

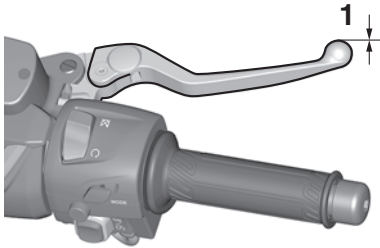

1. No brake lever free play

Rear

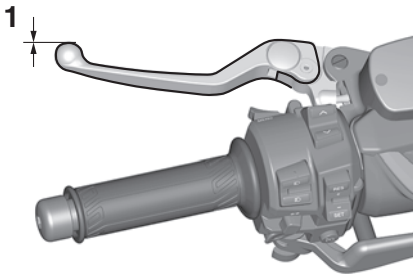

1. No brake lever free play

There should be no free play at the brake lever ends. If there is free play, have a Yamaha dealer inspect the brake system.



WARNING

EWA14212

A soft or spongy feeling in the brake lever can indicate the presence of air in the hydraulic system. If there is air in the hydraulic system, have a Yamaha dealer bleed the system before operating the vehicle. Air in the hydraulic system will diminish the braking performance, which may result in loss of control and an accident.

Adjusting the rear brake lock cable

EAU53033

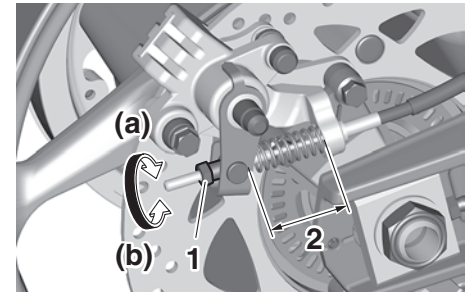

1. Adjusting nut
2. Rear brake lock cable length

Rear brake lock cable length:
43–45 mm (1.69–1.77 in)

Periodically check the rear brake lock cable length and adjust if necessary.

1. Release the rear brake lock lever.
2. To increase the rear brake lock cable length, turn the adjusting nut at the rear brake caliper in direction (a). To decrease the rear brake lock cable length, turn the adjusting nut in direction (b).

3. Confirm that the rear brake lock lever (page 5-18) functions properly and that the rear wheel rotates freely when unlocked.

EWA20290

WARNING

If proper adjustment cannot be obtained as described, have a Yamaha dealer make this adjustment.

Checking the rear brake lock EAU52293

The rear brake lock must be checked at the intervals specified in the periodic maintenance and lubrication chart.

1. Adjust the rear brake lock cable.
2. Apply the rear brake lock, and then try to push the vehicle to confirm that the rear brake lock functions properly.
3. The rear brake lock caliper is provided with a wear indicator, which allows you to check the rear brake lock pads. To check the rear brake lock pads, check the position of the indicator when the rear brake lock lever is applied. If the indicator has passed the wear indicator groove, have a Yamaha dealer check the rear brake lock.
4. Make sure that there are no tears or cracks on the rubber boot.

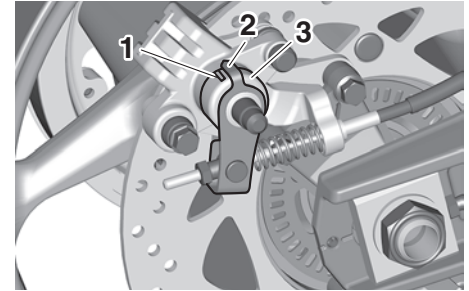

1. Wear indicator groove
2. Wear indicator
3. Rubber boot

Periodic maintenance and adjustment

Checking the front and rear brake pads

EAU22312

Front brake

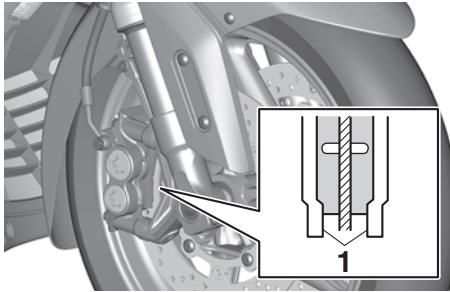

1. Brake pad wear indicator

The front and rear brake pads must be checked for wear at the intervals specified in the periodic maintenance and lubrication chart. Each brake pad is provided with a wear indicator, which allows you to check the brake pad wear without having to disassemble the brake. To check the brake pad wear, check the position of the wear indicator while applying the brake. If a brake pad has worn to the point that the wear indicator almost touches the brake disc, have a Yamaha dealer replace the brake pads as a set.

Rear brake

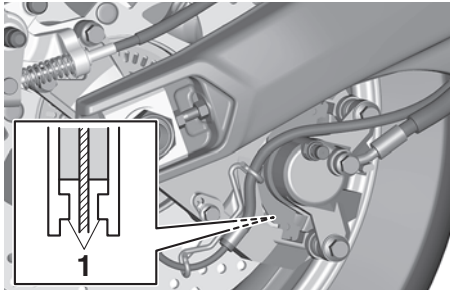

1. Brake pad wear indicator

Checking the brake fluid level

EAU22583

Before riding, check that the brake fluid is above the minimum level mark. Check the brake fluid level with the reservoir in an upright position. Replenish the brake fluid if necessary.

Specified brake fluid:
DOT 4

ECA17641

NOTICE

Brake fluid may damage painted surfaces or plastic parts. Always clean up spilled fluid immediately.

Front brake

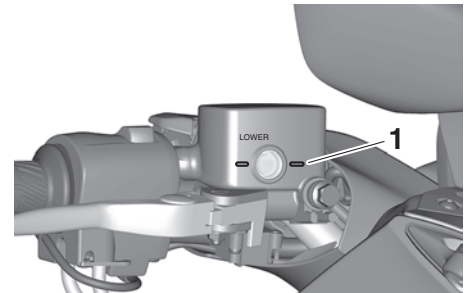

1. Minimum level mark

Rear brake

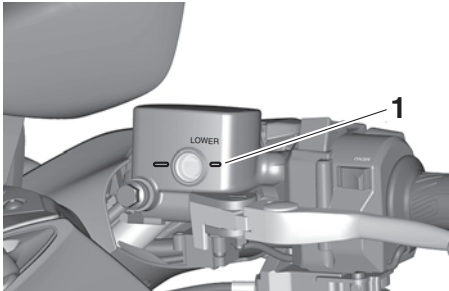

1. Minimum level mark

As the brake pads wear, it is normal for the brake fluid level to gradually go down.

- A low brake fluid level may indicate worn brake pads or brake system leakage; therefore, be sure to check the brake pads for wear and the brake system for leakage.
- If the brake fluid level goes down suddenly, have a Yamaha dealer check the cause before further riding.

EWA15991

WARNING

Improper maintenance can result in loss of braking ability. Observe these precautions:

- **Insufficient brake fluid may allow air to enter the brake system, reducing braking performance.**
- **Clean the filler cap before removing. Use only DOT 4 brake fluid from a sealed container.**
- **Use only the specified brake fluid; otherwise, the rubber seals may deteriorate, causing leakage.**
- **Refill with the same type of brake fluid. Adding a brake fluid other than DOT 4 may result in a harmful chemical reaction.**
- **Be careful that water does not enter the brake fluid reservoir when refilling. Water will significantly lower the boiling point of the fluid and may result in vapor lock.**

Changing the brake fluid

Have a Yamaha dealer change the brake fluid every 2 years. In addition, have the seals of the master cylinders and brake calipers, as well as the brake hoses replaced at the intervals listed below or sooner if they are damaged or leaking.

- Brake seals: every 2 years
- Brake hoses: every 4 years

Periodic maintenance and adjustment

EAU88810

Drive belt

The drive belt should be visually inspected before each ride. Check for excessive wear, damage, and dirt. Also, the drive belt tension must be checked and adjusted by a Yamaha dealer at the intervals specified in the periodic maintenance chart.

To check the drive belt

1. On a level surface, place the vehicle on its centerstand.
2. Rotate the rear wheel and check the belt surface for signs of wear or damage.

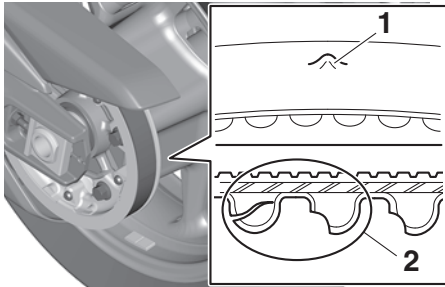

1. Stone damage
2. Cog damage

3. If cracks, excessive wear, or damage is found, have the belt inspected or replaced by your Yamaha dealer.
4. If the drive belt or drive belt sprocket is dirty, remove the drive belt covers by removing the bolts and quick fasteners.

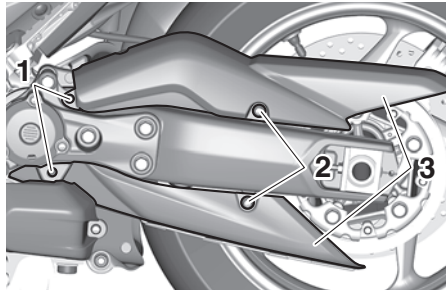

1. Quick fastener
2. Bolt
3. Drive belt cover

5. Clean the drive belt and remove any debris from the drive belt sprocket. **NOTICE: Do not allow dirt or sand to accumulate in the drive belt area, otherwise the drive belt will wear out quickly.**

[ECA26970]

6. Install the drive belt covers by installing the bolts and quick fasteners.

Checking and lubricating the cables

EAU23098

The operation of all control cables and the condition of the cables should be checked before each ride, and the cables and cable ends should be lubricated if necessary. If a cable is damaged or does not move smoothly, have a Yamaha dealer check or replace it. **WARNING! Damage to the outer housing of cables may result in internal rusting and cause interference with cable movement. Replace damaged cables as soon as possible to prevent unsafe conditions.** [EWA10712]

Recommended lubricant:

Yamaha cable lubricant or other suitable cable lubricant

Checking and lubricating the throttle grip and cable

EAU23115

The operation of the throttle grip should be checked before each ride. In addition, the cable should be lubricated by a Yamaha dealer at the intervals specified in the periodic maintenance chart.

The throttle cable is equipped with a rubber cover. Make sure that the cover is securely installed. Even though the cover is installed correctly, it does not completely protect the cable from water entry. Therefore, use care not to pour water directly onto the cover or cable when washing the vehicle. If the cable or cover becomes dirty, wipe clean with a moist cloth.

Lubricating the front and rear brake levers

EAU23173

Front brake lever

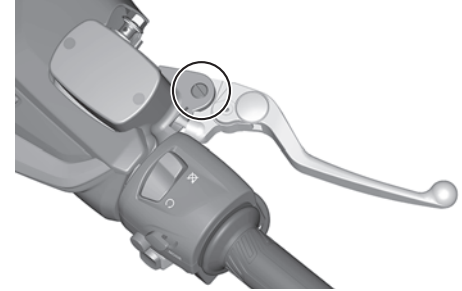

Rear brake lever

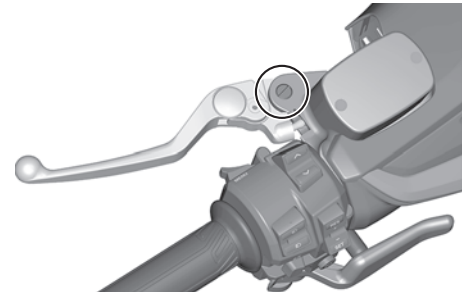

The pivoting points of the front and rear brake levers must be lubricated at the intervals specified in the periodic maintenance and lubrication chart.

Periodic maintenance and adjustment

Recommended lubricant:
Silicone grease

Checking and lubricating the centerstand and sidestand EAU23215

Recommended lubricant:
Lithium-soap-based grease

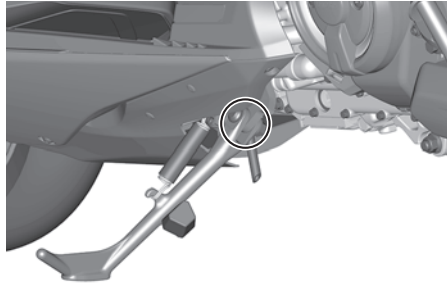

The operation of the centerstand and sidestand should be checked before each ride, and the pivots and metal-to-metal contact surfaces should be lubricated if necessary.

EWA10742

WARNING

If the centerstand or sidestand does not move up and down smoothly, have a Yamaha dealer check or repair it. Otherwise, the centerstand or sidestand could contact the ground and distract the operator, resulting in a possible loss of control.

EAU23273

Checking the front fork

The condition and operation of the front fork must be checked as follows at the intervals specified in the periodic maintenance and lubrication chart.

To check the condition

Check the inner tubes for scratches, damage and excessive oil leakage.

To check the operation

1. Place the vehicle on a level surface and hold it in an upright position. **WARNING! To avoid injury, securely support the vehicle so there is no danger of it falling over.** [EWA10752]
2. While applying the front brake, push down hard on the handlebars several times to check if the front fork compresses and rebounds smoothly.

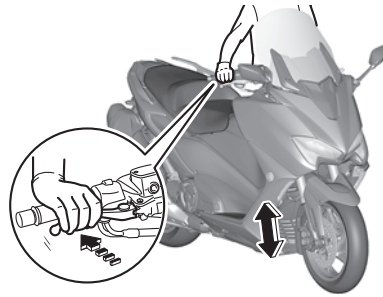

ECA10591

NOTICE

If any damage is found or the front fork does not operate smoothly, have a Yamaha dealer check or repair it.

EAU45512

Checking the steering

Worn or loose steering bearings may cause danger. Therefore, the operation of the steering must be checked as follows at the intervals specified in the periodic maintenance and lubrication chart.

1. Place the vehicle on the centerstand. **WARNING! To avoid injury, securely support the vehicle so there is no danger of it falling over.** [EWA10752]
2. Hold the lower ends of the front fork legs and try to move them forward and backward. If any free play can be felt, have a Yamaha dealer check or repair the steering.

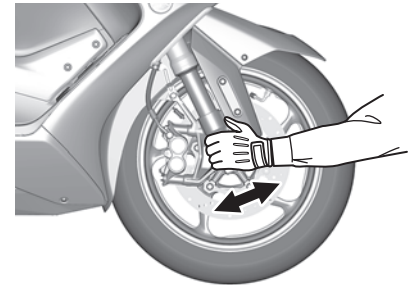

Periodic maintenance and adjustment

Checking the wheel bearings

EAU23292



The front and rear wheel bearings must be checked at the intervals specified in the periodic maintenance and lubrication chart. If there is play in the wheel hub or if the wheel does not turn smoothly, have a Yamaha dealer check the wheel bearings.

8

Battery

EAU7780

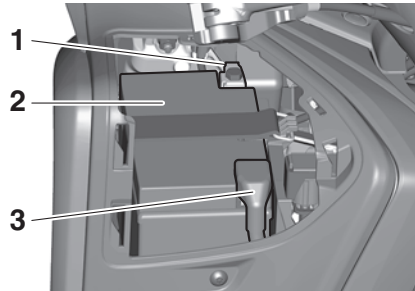

1. Negative battery lead (black)
2. Battery
3. Positive battery lead (red)

The battery is located under panel B. (See page 8-9.)

This model is equipped with a VRLA (Valve Regulated Lead Acid) battery. There is no need to check the electrolyte or to add distilled water. However, the battery lead connections need to be checked and, if necessary, tightened.

EWA10761



WARNING

- **Electrolyte is poisonous and dangerous since it contains sulfuric acid, which causes severe**

burns. Avoid any contact with skin, eyes or clothing and always shield your eyes when working near batteries. In case of contact, administer the following **FIRST AID**.

- **EXTERNAL:** Flush with plenty of water.
- **INTERNAL:** Drink large quantities of water or milk and immediately call a physician.
- **EYES:** Flush with water for 15 minutes and seek prompt medical attention.
- **Batteries produce explosive hydrogen gas. Therefore, keep sparks, flames, cigarettes, etc., away from the battery and provide sufficient ventilation when charging it in an enclosed space.**
- **KEEP THIS AND ALL BATTERIES OUT OF THE REACH OF CHILDREN.**

To charge the battery

Have a Yamaha dealer charge the battery as soon as possible if it seems to have discharged. Keep in mind that the

Periodic maintenance and adjustment

battery tends to discharge more quickly if the vehicle is equipped with optional electrical accessories.

ECA16522

NOTICE

To charge a VRLA (Valve Regulated Lead Acid) battery, a special (constant-voltage) battery charger is required. Using a conventional battery charger will damage the battery.

To store the battery

1. If the vehicle will not be used for more than one month, remove the battery, fully charge it, and then place it in a cool, dry place.
NOTICE: When removing the battery, be sure turn the vehicle power off, then disconnect the negative lead before disconnecting the positive lead. [ECA21900]
2. If the battery will be stored for more than two months, check it at least once a month and fully charge it if necessary.

3. Fully charge the battery before installation. **NOTICE: When installing the battery, connect the positive lead before connecting the negative lead.** [ECA21910]
4. After installation, make sure that the battery leads are properly connected to the battery terminals.

ECA16531

NOTICE

Always keep the battery charged. Storing a discharged battery can cause permanent battery damage.

Replacing the fuses

EAU81472

Fuse box 1, brake light fuse and cruise control fuse are located behind panel A. (See page 8-9.)

Fuse box 2 and main fuse are located behind the windshield.

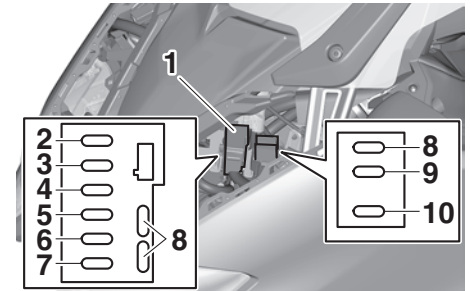

1. Fuse box 1
2. ABS control unit fuse
3. Auxiliary DC jack fuse
4. Headlight fuse
5. Electronic throttle valve fuse
6. ABS motor fuse
7. ABS solenoid fuse
8. Spare fuse
9. Cruise control fuse (XP560D)
10. Brake light fuse (XP560D)

Periodic maintenance and adjustment

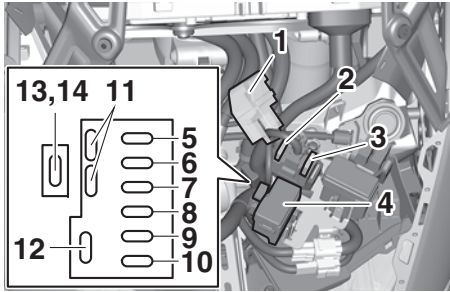

1. Starter relay cover
2. Main fuse
3. Spare main fuse
4. Fuse box 2
5. Signaling system fuse
6. Ignition fuse
7. Taillight fuse
8. Radiator fan motor fuse
9. Fuel injection system fuse
10. Backup fuse
11. Spare fuse
12. Spare fuse (XP560D)
13. Windshield motor fuse (XP560D)
14. Baggage fuse (XP560E)

TIP

To access the main fuse, remove the starter relay cover.

To access fuse box 2 and the main fuse, proceed as follows.

1. Remove the screw access covers by removing the quick fasteners.

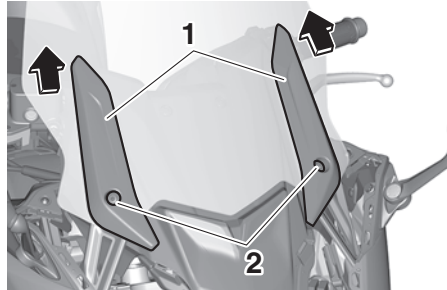

1. Screw access cover
2. Quick fastener

2. Remove the caps.

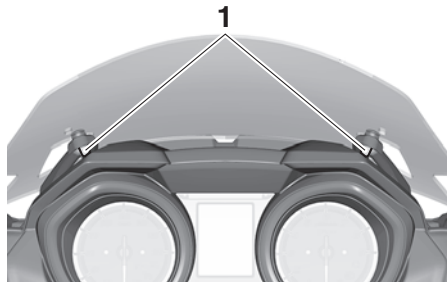

1. Cap

3. Remove the windshield by removing the screws.

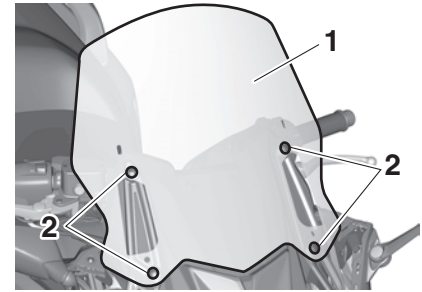

1. Windshield
2. Screw

4. Remove the inner panel by removing the bolts and quick fasteners.

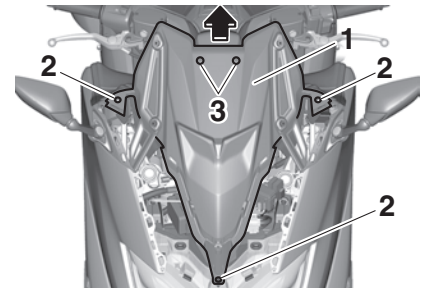

1. Inner panel
2. Bolt
3. Quick fastener

5. Install the inner panel by installing the bolts and quick fasteners.

Periodic maintenance and adjustment

6. Install the windshield by installing the screws.
7. Install the caps.
8. Install the screw access covers by installing the quick fasteners.

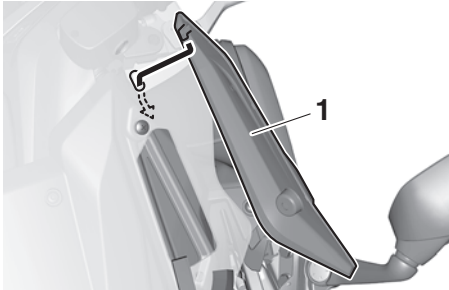

1. Screw access cover

If a fuse is blown, replace it as follows.

1. Turn the vehicle power off.
2. Remove the blown fuse, and then install a new fuse of the specified amperage. **WARNING! Do not use a fuse of a higher amperage rating than recommended to avoid causing extensive damage to the electrical system and possibly a fire.** [EWA15132]

Specified fuses:

- Main fuse:
40.0 A
- Headlight fuse:
7.5 A
- Taillight fuse:
7.5 A
- Signaling system fuse:
7.5 A
- Ignition fuse:
7.5 A
- Radiator fan motor fuse:
15.0 A
- Fuel injection system fuse:
7.5 A
- ABS control unit fuse:
7.5 A
- ABS motor fuse:
30.0 A
- ABS solenoid fuse:
15.0 A
- Auxiliary DC jack fuse:
2.0 A
- Backup fuse:
15.0 A
- Electronic throttle valve fuse:
7.5 A
- Baggage fuse:
7.5 A (XP560E)
- Brake light fuse:
1.0 A (XP560D)
- Cruise control fuse:
1.0 A (XP560D)
- Windshield motor fuse:
20.0 A (XP560D)

3. Turn the vehicle power on and turn on the electrical circuit in question to check if the device operates.
4. If the fuse immediately blows again, have a Yamaha dealer check the electrical system.

Periodic maintenance and adjustment

Vehicle lights

EAU80380

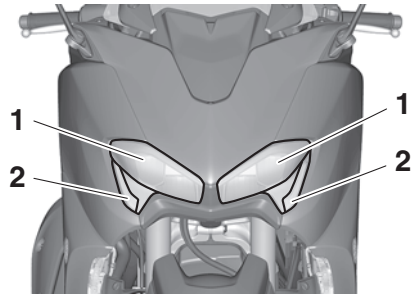

1. Headlight
2. Auxiliary light

Except for the license plate light bulb, this model's lights are all LED.

If an LED light does not come on, check the fuses and then have a Yamaha dealer check the vehicle. If the license plate light does not come on, check and replace the bulb. (See page 8-34.)

ECA16581

NOTICE

Do not affix any type of tinted film or stickers to the headlight lens.

Replacing the license plate light bulb

EAU81491

1. Remove the nuts securing the license plate light unit.

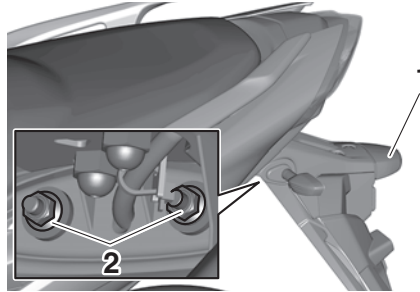

1. License plate light unit
2. Nut

2. Pull the license plate light unit separate from the rear fender. (Reinstall the collars if they fall out.)

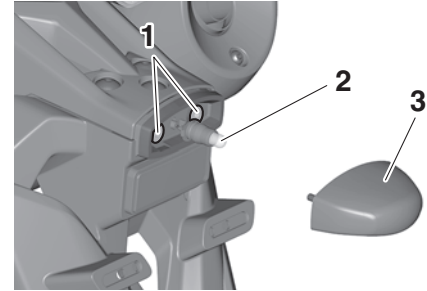

1. Collar
2. License plate light bulb
3. License plate light unit

3. Remove the burnt-out bulb by pulling it out.
4. Insert a new bulb into the socket, and push the socket in place.
5. Install the license plate unit onto the rear fender.
6. Install the nuts and tighten to the specified torque.

Tightening torque:

License plate light unit nut:
3.8 N·m (0.38 kgf·m, 2.8 lb·ft)

Troubleshooting

EAU25865

Although your Yamaha received a thorough inspection before shipment from the factory, trouble may occur during operation. Any problem in the fuel, compression, or ignition systems, for example, can cause poor starting and loss of power.

The following troubleshooting chart represents a quick and easy procedure for checking these vital systems yourself. However, should your vehicle require any repair, take it to an authorized Yamaha dealer whose skilled technicians have the necessary tools, experience, and know-how to properly service your Yamaha vehicle. Be sure to use only genuine Yamaha replacement parts. Although imitation parts may look similar to genuine parts, they are often inferior in quality, have a shorter service life, and can lead to an expensive repair bill later on.

EWA15142



When checking the fuel system, do not smoke, and make sure there are no open flames or sparks in the ar-

ea, including pilot lights from water heaters or furnaces. Gasoline or gasoline vapors can ignite or explode, causing severe injury or property damage.

EAU77992

Smart key system troubleshooting

Please check the following items when the smart key system does not work.

- Is the smart key turned on? (See page 3-5.)
- Is the smart key battery discharged? (See page 3-6.)
- Is the smart key battery installed correctly? (See page 3-6.)
- Is the smart key being used in a location with strong radio waves or other electromagnetic noise? (See page 3-1.)
- Are you using the smart key that is registered to the vehicle?
- Is the vehicle battery discharged? When the vehicle battery is discharged, the smart key system will not operate. Please have the vehicle battery charged or replaced. (See page 8-30.)

If the smart key system does not work after checking the above items, have a Yamaha dealer check the smart key system.

TIP

See Emergency mode on page 8-38 for information on starting the engine without the smart key.

Periodic maintenance and adjustment

EAU86350

Troubleshooting chart

1. Fuel

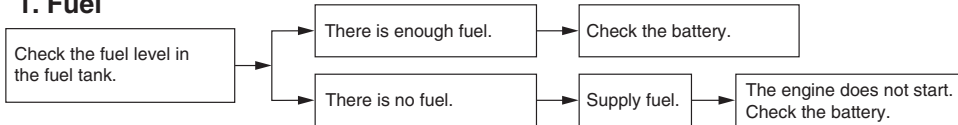

2. Battery

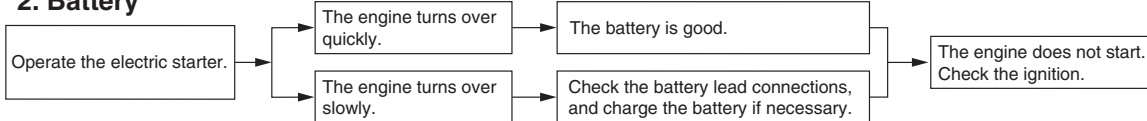

3. Ignition

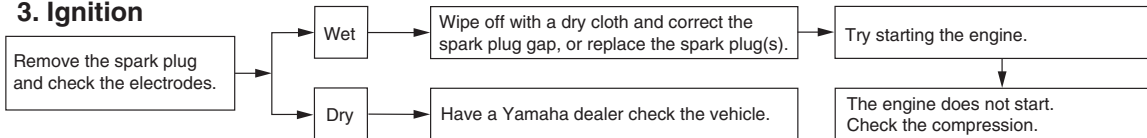

4. Compression

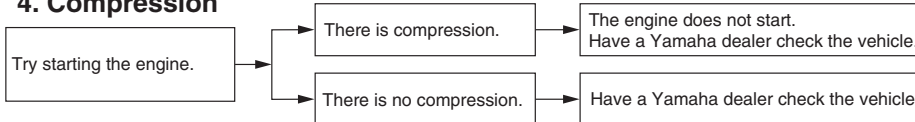

Periodic maintenance and adjustment

EAU86420

Engine overheating

EWAT1041

WARNING

- Do not remove the radiator cap when the engine and radiator are hot. Scalding hot fluid and steam may be blown out under pressure, which could cause serious injury. Be sure to wait until the engine has cooled.
- Place a thick rag, like a towel, over the radiator cap, and then slowly rotate the cap counterclockwise to the detent to allow any residual pressure to escape. When the hissing sound has stopped, press down on the cap while turning it counterclockwise, and then remove the cap.

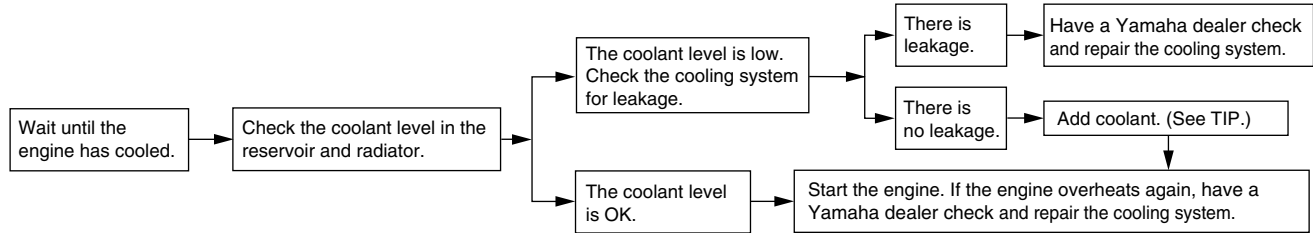

TIP

If coolant is not available, tap water can be temporarily used instead, provided that it is changed to the recommended coolant as soon as possible.

Periodic maintenance and adjustment

EAU77373

Emergency mode

When the smart key is lost, damaged, or its battery has discharged, the vehicle can still be turned on and the engine started. You will need a mechanical key and the smart key system identification number. To operate the vehicle in emergency mode, carry out the following steps.

TIP

Emergency mode operation will be cancelled if the respective steps are not carried out within the time set for each operation or if the “OFF/LOCK” switch is pushed.

1. Stop the vehicle in a safe place.
2. Unlock the seat by inserting the mechanical key into the lock located right side of body and turn it counter clockwise.

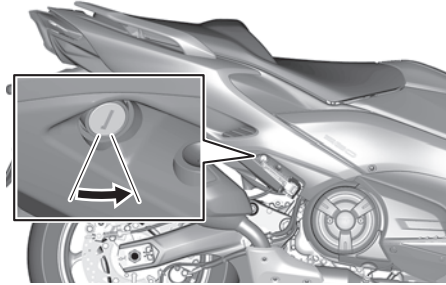



3. Open the seat and check that the trunk light comes on.
4. Push the “ON/⊞” switch once.
5. Without completely shutting the seat, raise and lower it three times within 10 seconds.

TIP

Use the rear storage compartment light as a guide when raising and lowering the seat.

The smart key system indicator light on the speedometer will come on for three seconds to indicate the transition to emergency mode.



1. Smart key system indicator light “
 6. After the smart key system indicator light goes off, use the “/” switch to enter the identification number.

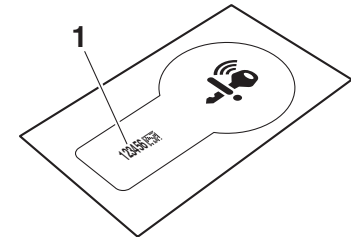

1. Identification number

Periodic maintenance and adjustment

7. Inputting the identification number is done by counting the number of flashes of the smart key system indicator light.

For example, if the identification number is 123456:

Push and hold the “” switch.



The smart key system indicator light will start to flash.



Release the “” switch after the smart key system indicator light flashes once.



The first digit of the identification number has been set as “1”.



Push and hold the “” switch again.



Release the “” switch after the smart key system indicator light flashes twice.



The second digit has been set as “2”.



Repeat the above procedure until all digits of the identification number have been set. The smart key system indicator light will come on for 10 seconds if the correct identification number was entered.

TIP

Emergency mode will be terminated when either one of the following situations apply. In this case, start over again from step 4.

- When there are no “” switch operations for 10 seconds during the identification number input process.

- When the smart key system indicator light is allowed to flash 9 or more times.

8. Press the “ON/” switch while the smart key system indicator light is on to turn on the power to the vehicle. The engine can now be started.

TIP

- If the identification number is not correctly entered, the smart key system indicator light will flash rapidly for 3 seconds and emergency mode is terminated. In this case, start over again from step 4.
- To lock the handlebar after turning on the vehicle in emergency mode, turn the vehicle power off, wait 30 seconds, and then turn the handlebar to the left and press the “OFF/LOCK” switch.

Scooter care and storage

EAU37834

Matte color caution

ECA15193

NOTICE

Some models are equipped with matte colored finished parts. Be sure to consult a Yamaha dealer for advice on what products to use before cleaning the vehicle. Using a brush, harsh chemical products or cleaning compounds when cleaning these parts will scratch or damage their surface. Wax also should not be applied to any matte colored finished parts.

EAU83443

Care

Frequent, thorough cleaning of the vehicle will not only enhance its appearance but also will improve its general performance and extend the useful life of many components. Washing, cleaning, and polishing will also give you a chance to inspect the condition of the vehicle more frequently. Be sure to wash the vehicle after riding in the rain or near the sea, because salt is corrosive to metals.

TIP

- The roads of heavy snowfall areas may be sprayed with salt as a de-icing method. This salt can stay on the roads well into spring, so be sure to wash the underside and chassis parts after riding in such areas.
 - Genuine Yamaha care and maintenance products are sold under the YAMALUBE brand in many markets worldwide.
 - See your Yamaha dealer for additional cleaning tips.
-

ECA26280

NOTICE

Improper cleaning can cause cosmetic and mechanical damage. Do not use:

- high-pressure washers or steam-jet cleaners. Excessive water pressure may cause water seepage and deterioration of wheel bearings, brakes, transmission seals and electrical devices. Avoid high-pressure detergent applications such as those available in coin-operated car washers.
- harsh chemicals, including strong acidic wheel cleaners, especially on spoke or magnesium wheels.
- harsh chemicals, abrasive cleaning compounds, or wax on matte-finished parts. Brushes can scratch and damage the matte-finish, use soft sponge or towel only.
- towels, sponges, or brushes contaminated with abrasive cleaning products or strong

chemicals such as, solvents, gasoline, rust removers, brake fluid, or antifreeze, etc.

Before washing

1. Park the vehicle out of direct sunlight and allow it to cool. This will help avoid water spots.
2. Make sure all caps, covers, electrical couplers and connectors are tightly installed.
3. Cover the muffler end with a plastic bag and a strong rubber band.
4. Pre-soak stubborn stains like insects or bird droppings with a wet towel for a few minutes.
5. Remove road grime and oil stains with a quality degreasing agent and a plastic-bristle brush or sponge. **NOTICE: Do not use degreasing agent on areas requiring lubrication such as seals, gaskets, and wheel axles. Follow product instructions.**

[ECA26290]

Washing

1. Rinse off any degreaser and spray down the vehicle with a garden hose. Use only enough pressure to do the job. Avoid spraying water directly into the muffler, instrument panel, air inlet, or other inner areas such as underseat storage compartments.
2. Wash the vehicle with a quality automotive-type detergent mixed with cool water and a soft, clean towel or sponge. Use an old toothbrush or plastic-bristle brush for hard-to-reach places. **NOTICE: Use cold water if the vehicle has been exposed to salt. Warm water will increase salt's corrosive properties.** [ECA26301]
3. For windshield-equipped vehicles: Clean the windshield with a soft towel or sponge dampened with water and a pH neutral detergent. If necessary, use a high-quality windshield cleaner or polish for motorcycles. **NOTICE: Never use any strong chemicals to clean the windshield. Additionally, some cleaning compounds for**

plastic may scratch the windshield, so be sure to test all cleaning products before general application.

[ECA26310]

4. Rinse off thoroughly with clean water. Be sure to remove all detergent residues, as they can be harmful to plastic parts.

After washing

1. Dry the vehicle with a chamois or absorbent towel, preferably microfiber terrycloth.
2. For drive chain-equipped models: Dry and then lubricate the drive chain to prevent rust.
3. Use a chrome polish to shine chrome, aluminum, and stainless steel parts. Often the thermally induced discoloring of stainless steel exhaust systems can be removed through polishing.
4. Apply a corrosion protection spray on all metal parts including chrome or nickel-plated surfaces. **WARNING! Do not apply silicone or oil spray to seats, hand grips, rubber foot pegs or tire treads. Otherwise these parts**

Scooter care and storage

EAU83472

will become slippery, which could cause loss of control. **Thoroughly clean the surfaces of these parts before operating the vehicle.** [EWA20650]

5. Treat rubber, vinyl, and unpainted plastic parts with a suitable care product.
6. Touch up minor paint damage caused by stones, etc.
7. Wax all painted surfaces using a non-abrasive wax or use a detail spray for motorcycles.
8. When finished cleaning, start the engine and let it idle for several minutes to help dry any remaining moisture.
9. If the headlight lens has fogged up, start the engine and turn on the headlight to help remove the moisture.
10. Let the vehicle dry completely before storing or covering it.

ECA26320

NOTICE

- **Do not apply wax to rubber or unpainted plastic parts.**

- **Do not use abrasive polishing compounds as they will wear away the paint.**
- **Apply sprays and wax sparingly. Wipe off excess afterwards.**

EWA20660



Contaminants left on the brakes or tires can cause loss of control.

- **Make sure there is no lubricant or wax on the brakes or tires.**
- **If necessary, wash the tires with warm water and a mild detergent.**
- **If necessary, clean the brake discs and pads with brake cleaner or acetone.**
- **Before riding at higher speeds, test the vehicle's braking performance and cornering behavior.**

Storage

Always store the vehicle in a cool, dry place. If necessary, protect it against dust with a porous cover. Be sure the engine and the exhaust system are cool before covering the vehicle. If the vehicle often sits for weeks at a time between uses, the use of a quality fuel stabilizer is recommended after each fill-up.

ECA21170

NOTICE

- **Storing the vehicle in a poorly ventilated room or covering it with a tarp, while it is still wet, will allow water and humidity to seep in and cause rust.**
- **To prevent corrosion, avoid damp cellars, stables (because of the presence of ammonia) and areas where strong chemicals are stored.**

Long term storage

Before storing the vehicle long term (60 days or more):

Scooter care and storage

1. Make all necessary repairs and perform any outstanding maintenance.
2. Follow all instructions in the Care section of this chapter.
3. Fill up the fuel tank, adding fuel stabilizer according to product instructions. Run the engine for 5 minutes to distribute treated fuel through the fuel system.
4. For vehicles equipped with a fuel cock: Turn the fuel cock lever to the off position.
5. For vehicles with a carburetor: To prevent fuel deposits from building up, drain the fuel in the carburetor float chamber into a clean container. Retighten the drain bolt and pour the fuel back into the fuel tank.
6. Use a quality engine fogging oil according to product instructions to protect internal engine components from corrosion. If engine fogging oil is not available, perform the following steps for each cylinder:
 - a. Remove the spark plug cap and spark plug.
 - b. Pour a teaspoonful of engine oil into the spark plug bore.
 - c. Install the spark plug cap onto the spark plug, and then place the spark plug on the cylinder head so that the electrodes are grounded. (This will limit sparking during the next step.)
 - d. Turn the engine over several times with the starter. (This will coat the cylinder wall with oil.)
WARNING! To prevent damage or injury from sparking, make sure to ground the spark plug electrodes while turning the engine over.
[EWA10952]
 - e. Remove the spark plug cap from the spark plug, and then install the spark plug and the spark plug cap.
7. Lubricate all control cables, pivots, levers and pedals, as well as the sidestand and centerstand (if equipped).
8. Check and correct the tire air pressure, and then lift the vehicle so that all wheels are off the ground. Otherwise, turn the wheels a little once a month in order to prevent the tires from becoming degraded in one spot.
9. Cover the muffler outlet with a plastic bag to prevent moisture from entering it.
10. Remove the battery and fully charge it, or attach a maintenance charger to keep the battery optimally charged. **NOTICE: Confirm that the battery and its charger are compatible. Do not charge a VRLA battery with a conventional charger.** [ECA26330]

TIP

- If the battery will be removed, charge it once a month and store it in a temperate location between 0-30 °C (32-90 °F).
- See page 8-30 for more information on charging and storing the battery.

Specifications

Dimensions:

- Overall length:
 - 2200 mm (86.6 in)
- Overall width:
 - 765 mm (30.1 in)
- Overall height:
 - 1420/1475 mm (55.9/58.1 in) (XP560E)
 - 1420/1555 mm (55.9/61.2 in) (XP560D)
- Seat height:
 - 800 mm (31.5 in)
- Wheelbase:
 - 1575 mm (62.0 in)
- Ground clearance:
 - 125 mm (4.92 in)
- Minimum turning radius:
 - 2.8 m (9.19 ft)

Weight:

- Curb weight:
 - 218 kg (481 lb) (XP560E)
 - 220 kg (485 lb) (XP560D)

Engine:

- Combustion cycle:
 - 4-stroke
- Cooling system:
 - Liquid cooled
- Valve train:
 - DOHC
- Cylinder arrangement:
 - Inline
- Number of cylinders:
 - 2-cylinder
- Displacement:
 - 562 cm³

Bore × stroke:
70.0 × 73.0 mm (2.76 × 2.87 in)

Starting system:
Electric starter

Engine oil:

Recommended brand:



SAE viscosity grades:
10W-40

Recommended engine oil grade:
API service SG type or higher, JASO
standard MA

Engine oil quantity:
Oil change:
2.60 L (2.75 US qt, 2.29 Imp.qt)
With oil filter removal:
2.90 L (3.07 US qt, 2.55 Imp.qt)

Coolant quantity:

Coolant reservoir (up to the maximum level
mark):
0.25 L (0.26 US qt, 0.22 Imp.qt)
Radiator (including all routes):
1.54 L (1.63 US qt, 1.36 Imp.qt)

Fuel:

Recommended fuel:
Unleaded gasoline (E10 acceptable)
Octane number (RON):
95
Fuel tank capacity:
15 L (4.0 US gal, 3.3 Imp.gal)

Fuel reserve amount:
3.0 L (0.79 US gal, 0.66 Imp.gal)

Fuel injection:

Throttle body:
ID mark:
B7M1 00

Front tire:

Type:
Tubeless
Size:
120/70R15M/C 56H
Manufacturer/model:
BRIDGESTONE/BATTLAX SCF

Rear tire:

Type:
Tubeless
Size:
160/60R15M/C 67H
Manufacturer/model:
BRIDGESTONE/BATTLAX SCR

Loading:

Maximum load:
195 kg (430 lb) (XP560D)
197 kg (434 lb) (XP560E)
(Total weight of rider, passenger, cargo and
accessories)

Front brake:

Type:
Hydraulic dual disc brake

Rear brake:

Type:
Hydraulic single disc brake

Front suspension:

Type:
Telescopic fork

Rear suspension:

Type:
Swingarm (link suspension)

Electrical system:

System voltage:
12 V

Battery:

Model:
YTZ12S
Voltage, capacity:
12 V, 11.0 Ah (10 HR)

Bulb wattage:

Headlight:
LED
Brake/tail light:
LED
Front turn signal light:
LED
Rear turn signal light:
LED
Auxiliary light:
LED
License plate light:
5.0 W

Consumer information

Identification numbers

EAU53562

Record the vehicle identification number, engine serial number, and the model label information in the spaces provided below. These identification numbers are needed when registering the vehicle with the authorities in your area and when ordering spare parts from a Yamaha dealer.

VEHICLE IDENTIFICATION NUMBER:

ENGINE SERIAL NUMBER:

MODEL LABEL INFORMATION:

Vehicle identification number

EAU26411

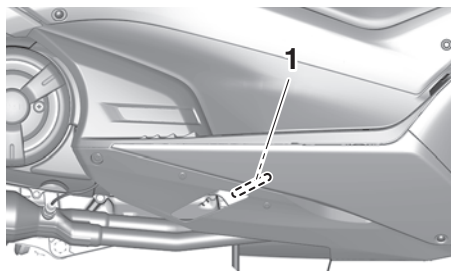

1. Vehicle identification number

The vehicle identification number is stamped into the frame.

TIP

The vehicle identification number is used to identify your vehicle and may be used to register it with the licensing authority in your area.

Engine serial number

EAU26442

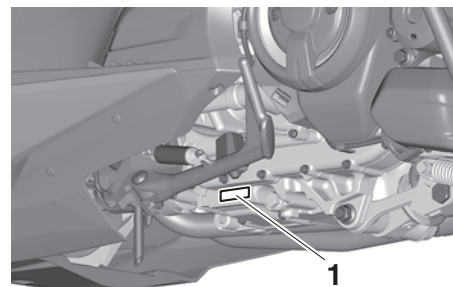

1. Engine serial number

The engine serial number is stamped into the crankcase.

Model label

EAU26501

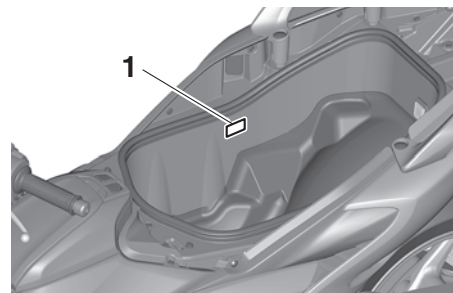

1. Model label

The model label is affixed to the inside of the rear storage compartment. (See page 5-23.) Record the information on this label in the space provided. This information will be needed when ordering spare parts from a Yamaha dealer.

Diagnostic connector

EAU69910

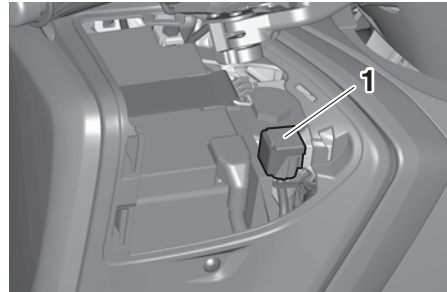

1. Diagnostic connector

The diagnostic connector is located as shown.

Vehicle data recording

EAU85300

This model's ECU stores certain vehicle data to assist in the diagnosis of malfunctions and for research, statistical analysis and development purposes.

Although the sensors and recorded data will vary by model, the main data points are:

- Vehicle status and engine performance data
- Fuel-injection and emission-related data

This data will be uploaded only when a special Yamaha diagnostic tool is attached to the vehicle, such as when maintenance checks or service procedures are performed.

Vehicle data uploaded will be handled appropriately according to the following Privacy Policy.

Privacy Policy

<https://www.yamaha-motor.eu/eu/privacy/privacy-policy.aspx>

Consumer information

Yamaha will not disclose this data to a third party except in the following cases. In addition, Yamaha may provide vehicle data to a contractor in order to outsource services related to the handling of vehicle data. Even in this case, Yamaha will require the contractor to properly handle the vehicle data we provided and Yamaha will appropriately manage the data.

- With the consent of the vehicle owner
- Where obligated by law
- For use by Yamaha in litigation
- When the data is not related to an individual vehicle nor owner

- A**
- ABS warning light 5-3
 - Acceleration and deceleration 7-3
 - Air filter element and check hose, replacing and cleaning 8-17
 - Anti-lock brake system (ABS) 5-19
 - Auxiliary DC jack 5-28
- B**
- Battery 8-30
 - Brake fluid, changing 8-25
 - Brake fluid level, checking 8-24
 - Brake lever, front 5-18
 - Brake lever, rear 5-18
 - Brake levers, lubricating 8-27
 - Braking 7-3
- C**
- Cables, checking and lubricating 8-27
 - Canister 8-12
 - Care 9-1
 - Catalytic converter 5-23
 - Centerstand and sidestand, checking and lubricating 8-28
 - Coolant 8-15
 - Cruise control indicator lights 5-3
 - Cruise control switches 5-2
 - Cruise control system (XP560D) 4-1
- D**
- Data recording, vehicle 11-2
 - Diagnostic connector 11-2
 - Dimmer/Pass switch 5-1
 - D-mode (drive mode) 4-3
 - Drive belt 8-26
 - Drive mode switch 5-2
- E**
- Emergency mode 8-38
 - Engine break-in 7-1
 - Engine idling speed, checking 8-18
 - Engine oil and oil filter cartridge 8-12
 - Engine overheating 8-37
 - Engine serial number 11-1
 - Engine stop switch 5-1
- F**
- Front and rear brake lever free play, checking 8-22
 - Front and rear brake pads, checking 8-24
 - Front fork, checking 8-29
 - Fuel 5-21
 - Fuel consumption, tips for reducing 7-4
 - Fuel tank cap 5-20
 - Fuel tank overflow hose 5-22
 - Fuses, replacing 8-31
- H**
- Handlebar switches 5-1
 - Hazard switch 5-2
 - High beam indicator light 5-3
 - Horn switch 5-1
 - How to lock the centerstand 3-10
 - How to lock the steering 3-9
- I**
- Identification numbers 11-1
 - Ignition circuit cut-off system 5-30
 - Indicator lights and warning lights 5-2
- K**
- Key, handling of smart and mechanical key 3-3
- L**
- License plate light bulb, replacing 8-34
- M**
- Maintenance and lubrication, periodic ... 8-5
 - Maintenance, emission control system 8-3
 - Malfunction indicator light (MIL) 5-3
 - Matte color, caution 9-1
 - Menu switch 5-2
 - Model label 11-1
 - Multi-function display 5-5
- O**
- Operating range of the smart key system 3-2
- P**
- Panels, removing and installing 8-9
 - Parking 7-4
 - Parking mode 3-13
 - Part locations 2-1
 - Powering off the vehicle 3-8
 - Powering on the vehicle 3-7
 - Power on/Starter switch 5-1
- R**
- Rear brake lock cable, adjusting 8-22
 - Rear brake lock, checking 8-23
 - Rear brake lock lever 5-18
 - Rear view mirrors 5-26
- S**
- Safe-riding points 1-5
 - Safety information 1-1
 - Select switch 5-2
 - Shock absorber assembly 5-27
 - Sidestand 5-29
 - Smart key 3-5
 - Smart key battery, replacing 3-6
 - Smart key system 3-1

Index

Smart key system indicator light5-4
Smart key system, troubleshooting8-35
Spark plugs, checking8-11
Special features4-1
Specifications10-1
Speedometer5-4
Starting off7-3
Starting the engine.....7-2
Steering, checking8-29
Storage9-3
Storage compartment and fuel tank
 access3-11
Storage compartments.....5-23

T

Tachometer5-5
Throttle grip and cable, checking and
 lubricating8-27
Throttle grip free play, checking8-18
Tires8-19
Tool kit8-2
Traction control system4-4
Traction control system indicator light ...5-4
Troubleshooting8-35
Troubleshooting chart.....8-36
Turn signal indicator lights5-2
Turn signal switch5-1

V

Valve clearance.....8-19
Vehicle identification number11-1
Vehicle lights.....8-34

W

Wheel bearings, checking.....8-30
Wheels8-21
Windshield (XP560E).....5-25

Y

Yamalube8-15

