



OWNER'S MANUAL

**⚠ Read this manual carefully  
before operating this vehicle.**



MOTORCYCLE

---

***YZF1000 (YZF-R1)***

***YZF1000D (YZF-R1M)***

B3L-28199-E0 ●

Safety information	1
Description	2
Special features	3
Instrument and control functions	4
For your safety – pre-operation checks	5
Operation and important riding points	6
Periodic maintenance and adjustment	7
Motorcycle care and storage	8
Specifications	9
Consumer information	10
Index	11

 **Read this manual carefully before operating this vehicle. This manual should stay with this vehicle if it is sold.**

Declaration of Conformity:

Hereby, YAMAHA MOTOR ELECTRONICS Co., Ltd declares that the radio equipment type, IMMOBILIZER, B3L-00 is in compliance with Directive 2014/53/EU.

The full text of the EU declaration of conformity is available at the following internet address:

[https://global.yamaha-motor.com/eu\\_doc/](https://global.yamaha-motor.com/eu_doc/)

Frequency band: 134.2 kHz

The maximum radio frequency power: 49.0 [dB $\mu$ V/m]

Manufacturer:

YAMAHA MOTOR ELECTRONICS Co., Ltd

1450-6 Mori, Mori-machi, Shuchi-Gun, Shizuoka, 437-0292 Japan

Importer:

YAMAHA MOTOR EUROPE N.V.

Koolhovenlaan 101, 1119 NC Schiphol-Rijk, 1117 ZN, Schiphol, the Netherlands

Declaration of Conformity:

Hereby, YAMAHA MOTOR CO., LTD declares that the radio equipment type, Communication Control Unit, 2KS-85800-00 is in compliance with Directive 2014/53/EU.

The full text of the EU declaration of conformity is available at the following internet address:

[https://global.yamaha-motor.com/eu\\_doc/](https://global.yamaha-motor.com/eu_doc/)

Frequency band: 2.4 GHz

The maximum radio frequency power: 50.12 mW

Manufacturer:

YAMAHA MOTOR CO., LTD

2500 Shingai, Iwata, Shizuoka, 438-8501 Japan

Importer:

YAMAHA MOTOR EUROPE N.V.

Koolhovenlaan 101, 1119 NC Schiphol-Rijk, 1117 ZN, Schiphol, the Netherlands



Welcome to the Yamaha world of motorcycling!

As the owner of the YZF1000 / YZF1000D, you are benefiting from Yamaha's vast experience and newest technology regarding the design and manufacture of high-quality products, which have earned Yamaha a reputation for dependability. Please take the time to read this manual thoroughly, so as to enjoy all advantages of your YZF1000 / YZF1000D. The Owner's Manual does not only instruct you in how to operate, inspect and maintain your motorcycle, but also in how to safeguard yourself and others from trouble and injury.

In addition, the many tips given in this manual will help keep your motorcycle in the best possible condition. If you have any further questions, do not hesitate to contact your Yamaha dealer.

The Yamaha team wishes you many safe and pleasant rides. So, remember to put safety first!

Yamaha continually seeks advancements in product design and quality. Therefore, while this manual contains the most current product information available at the time of printing, there may be minor discrepancies between your motorcycle and this manual. If there is any question concerning this manual, please consult a Yamaha dealer.



---

**Please read this manual carefully and completely before operating this motorcycle.**



---

# Important manual information

---

EAU10134

Particularly important information is distinguished in this manual by the following notations:

	<b>This is the safety alert symbol. It is used to alert you to potential personal injury hazards. Obey all safety messages that follow this symbol to avoid possible injury or death.</b>
 <b>WARNING</b>	<b>A WARNING indicates a hazardous situation which, if not avoided, could result in death or serious injury.</b>
<b>NOTICE</b>	<b>A NOTICE indicates special precautions that must be taken to avoid damage to the vehicle or other property.</b>
<b>TIP</b>	A TIP provides key information to make procedures easier or clearer.

\*Product and specifications are subject to change without notice.

EAU10201

**YZF1000 / YZF1000D  
OWNER'S MANUAL**  
©2020 by Yamaha Motor Co., Ltd.  
1st edition, May 2019  
All rights reserved.  
Any reprinting or unauthorized use  
without the written permission of  
Yamaha Motor Co., Ltd.  
is expressly prohibited.  
Printed in Japan.

# Table of contents

---

<b>Safety information</b> .....	1-1	Seat cover (for equipped models) .....	4-40	General maintenance and lubrication chart .....	7-5
<b>Description</b> .....	2-1	Document storage .....	4-41	Removing and installing cowlings and panels.....	7-9
Left view .....	2-1	Rear view mirrors .....	4-41	Checking the spark plugs.....	7-12
Right view.....	2-2	Adjusting the front fork .....	4-42	Canister .....	7-13
Controls and instruments .....	2-3	Adjusting the shock absorber assembly.....	4-45	Engine oil and oil filter cartridge ...	7-14
<b>Special features</b> .....	3-1	EXUP system .....	4-48	Why Yamalube.....	7-17
YRC (Yamaha Ride Control) .....	3-1	Auxiliary DC connector .....	4-49	Coolant .....	7-17
Glossary .....	3-5	Sidestand .....	4-49	Air filter element.....	7-18
YRC functions visual guide .....	3-6	Ignition circuit cut-off system .....	4-50	Checking the engine idling speed .....	7-19
<b>Instrument and control functions</b> ...	4-1	<b>For your safety – pre-operation checks</b> .....	5-1	Valve clearance.....	7-19
Immobilizer system.....	4-1	<b>Operation and important riding points</b> .....	6-1	Tires .....	7-19
Main switch/steering lock.....	4-2	Engine break-in.....	6-1	Cast magnesium wheels .....	7-22
Handlebar switches.....	4-3	Starting the engine.....	6-2	Adjusting the clutch lever free play.....	7-23
Indicator lights and warning lights.....	4-5	Shifting .....	6-3	Checking the brake lever free play.....	7-24
Display.....	4-9	Tips for reducing fuel consumption.....	6-4	Brake light switches .....	7-24
MENU screen .....	4-15	Parking .....	6-4	Checking the front and rear brake pads .....	7-25
Clutch lever .....	4-32	<b>Periodic maintenance and adjustment</b> .....	7-1	Checking the brake fluid level .....	7-25
Shift pedal .....	4-32	Tool kit .....	7-2	Changing the brake fluid .....	7-26
Brake lever.....	4-33	Periodic maintenance charts .....	7-3	Drive chain slack.....	7-27
Brake pedal .....	4-33	Periodic maintenance chart for the emission control system.....	7-3	Cleaning and lubricating the drive chain.....	7-28
Brake control system (BC).....	4-33			Checking and lubricating the cables.....	7-29
Fuel tank cap.....	4-35			Checking and lubricating the throttle grip.....	7-29
Fuel.....	4-35				
Fuel tank overflow hose .....	4-37				
Catalytic converter .....	4-38				
Seats .....	4-38				
CCU (for equipped models).....	4-39				



# Table of contents

---

Checking and lubricating the brake and shift pedals .....	7-30
Checking and lubricating the brake and clutch levers.....	7-30
Checking and lubricating the sidestand .....	7-31
Lubricating the swingarm pivots ...	7-31
Checking the front fork.....	7-32
Checking the steering .....	7-32
Checking the wheel bearings .....	7-33
Battery .....	7-33
Replacing the fuses.....	7-35
Vehicle lights .....	7-37
Supporting the motorcycle.....	7-38
Troubleshooting .....	7-38
Troubleshooting chart .....	7-39
<b>Motorcycle care and storage .....</b>	<b>8-1</b>
Matte color caution .....	8-1
Care .....	8-1
Storage.....	8-4
<b>Specifications.....</b>	<b>9-1</b>
<b>Consumer information .....</b>	<b>10-1</b>
Identification numbers.....	10-1
Diagnostic connector .....	10-2
Vehicle data recording .....	10-2
<b>Index .....</b>	<b>11-1</b>

## Be a Responsible Owner

As the vehicle's owner, you are responsible for the safe and proper operation of your motorcycle.

Motorcycles are single-track vehicles. Their safe use and operation are dependent upon the use of proper riding techniques as well as the expertise of the operator. Every operator should know the following requirements before riding this motorcycle.

He or she should:

- Obtain thorough instructions from a competent source on all aspects of motorcycle operation.
- Observe the warnings and maintenance requirements in this Owner's Manual.
- Obtain qualified training in safe and proper riding techniques.
- Obtain professional technical service as indicated in this Owner's Manual and/or when made necessary by mechanical conditions.

- Never operate a motorcycle without proper training or instruction. Take a training course. Beginners should receive training from a certified instructor. Contact an authorized motorcycle dealer to find out about the training courses nearest you.

## Safe Riding

Perform the pre-operation checks each time you use the vehicle to make sure it is in safe operating condition. Failure to inspect or maintain the vehicle properly increases the possibility of an accident or equipment damage. See page 5-1 for a list of pre-operation checks.

- This motorcycle is designed to carry the operator and a passenger.
- The failure of motorists to detect and recognize motorcycles in traffic is the predominating cause of automobile/motorcycle accidents. Many accidents have been caused by an automobile driver who did not see the motorcycle. Making yourself conspicuous ap-

pears to be very effective in reducing the chance of this type of accident.

### Therefore:

- Wear a brightly colored jacket.
- Use extra caution when you are approaching and passing through intersections, since intersections are the most likely places for motorcycle accidents to occur.
- Ride where other motorists can see you. Avoid riding in another motorist's blind spot.
- Never maintain a motorcycle without proper knowledge. Contact an authorized motorcycle dealer to inform you on basic motorcycle maintenance. Certain maintenance can only be carried out by certified staff.

- Many accidents involve inexperienced operators. In fact, many operators who have been involved in accidents do not even have a current motorcycle license.
  - Make sure that you are qualified and that you only lend your motorcycle to other qualified operators.
  - Know your skills and limits. Staying within your limits may help you to avoid an accident.
  - We recommend that you practice riding your motorcycle where there is no traffic until you have become thoroughly familiar with the motorcycle and all of its controls.
- Many accidents have been caused by error of the motorcycle operator. A typical error made by the operator is veering wide on a turn due to excessive speed or undercornering (insufficient lean angle for the speed).
  - Always obey the speed limit and never travel faster than warranted by road and traffic conditions.
- Always signal before turning or changing lanes. Make sure that other motorists can see you.
- The posture of the operator and passenger is important for proper control.
  - The operator should keep both hands on the handlebar and both feet on the operator footrests during operation to maintain control of the motorcycle.
  - The passenger should always hold onto the operator, the seat strap or grab bar, if equipped, with both hands and keep both feet on the passenger footrests. Never carry a passenger unless he or she can firmly place both feet on the passenger footrests.
- Never ride under the influence of alcohol or other drugs.
- This motorcycle is designed for on-road use only. It is not suitable for off-road use.

### **Protective Apparel**

The majority of fatalities from motorcycle accidents are the result of head injuries. The use of a safety helmet is the single most critical factor in the prevention or reduction of head injuries.

- Always wear an approved helmet.
- Wear a face shield or goggles. Wind in your unprotected eyes could contribute to an impairment of vision that could delay seeing a hazard.
- The use of a jacket, heavy boots, trousers, gloves, etc., is effective in preventing or reducing abrasions or lacerations.
- Never wear loose-fitting clothes, otherwise they could catch on the control levers, footrests, or wheels and cause injury or an accident.
- Always wear protective clothing that covers your legs, ankles, and feet. The engine or exhaust system become very hot during or after operation and can cause burns.
- A passenger should also observe the above precautions.

# Safety information

1

## Avoid Carbon Monoxide Poisoning

All engine exhaust contains carbon monoxide, a deadly gas. Breathing carbon monoxide can cause headaches, dizziness, drowsiness, nausea, confusion, and eventually death.

Carbon Monoxide is a colorless, odorless, tasteless gas which may be present even if you do not see or smell any engine exhaust. Deadly levels of carbon monoxide can collect rapidly and you can quickly be overcome and unable to save yourself. Also, deadly levels of carbon monoxide can linger for hours or days in enclosed or poorly ventilated areas. If you experience any symptoms of carbon monoxide poisoning, leave the area immediately, get fresh air, and SEEK MEDICAL TREATMENT.

- Do not run engine indoors. Even if you try to ventilate engine exhaust with fans or open windows and doors, carbon monoxide can rapidly reach dangerous levels.
- Do not run engine in poorly ventilated or partially enclosed areas such as barns, garages, or carports.

- Do not run engine outdoors where engine exhaust can be drawn into a building through openings such as windows and doors.

## Loading

Adding accessories or cargo to your motorcycle can adversely affect stability and handling if the weight distribution of the motorcycle is changed. To avoid the possibility of an accident, use extreme caution when adding cargo or accessories to your motorcycle. Use extra care when riding a motorcycle that has added cargo or accessories. Here, along with the information about accessories below, are some general guidelines to follow if loading cargo to your motorcycle:

The total weight of the operator, passenger, accessories and cargo must not exceed the maximum load limit.

**Operation of an overloaded vehicle could cause an accident.**

**Maximum load:**  
185 kg (408 lb)

When loading within this weight limit, keep the following in mind:

- Cargo and accessory weight should be kept as low and close to the motorcycle as possible. Securely pack your heaviest items as close to the center of the vehicle as possible and make sure to distribute the weight as evenly as possible on both sides of the motorcycle to minimize imbalance or instability.
- Shifting weights can create a sudden imbalance. Make sure that accessories and cargo are securely attached to the motorcycle before riding. Check accessory mounts and cargo restraints frequently.
- Properly adjust the suspension for your load (suspension-adjustable models only), and check the condition and pressure of your tires.
- Never attach any large or heavy items to the handlebar, front fork, or front fender. These items, including such cargo as sleeping bags, duffel bags, or

tents, can create unstable handling or a slow steering response.

- **This vehicle is not designed to pull a trailer or to be attached to a sidecar.**

### **Genuine Yamaha Accessories**

Choosing accessories for your vehicle is an important decision. Genuine Yamaha accessories, which are available only from a Yamaha dealer, have been designed, tested, and approved by Yamaha for use on your vehicle.

Many companies with no connection to Yamaha manufacture parts and accessories or offer other modifications for Yamaha vehicles. Yamaha is not in a position to test the products that these aftermarket companies produce. Therefore, Yamaha can neither endorse nor recommend the use of accessories not sold by Yamaha or modifications not specifically recommended by Yamaha, even if sold and installed by a Yamaha dealer.

### **Aftermarket Parts, Accessories, and Modifications**

While you may find aftermarket products similar in design and quality to genuine Yamaha accessories, recognize that some aftermarket accessories or modifications are not suitable because of potential safety hazards to you or others. Installing aftermarket products or having other modifications performed to your vehicle that change any of the vehicle's design or operation characteristics can put you and others at greater risk of serious injury or death. You are responsible for injuries related to changes in the vehicle.

Keep the following guidelines in mind, as well as those provided under "Loading" when mounting accessories.

- Never install accessories or carry cargo that would impair the performance of your motorcycle. Carefully inspect the accessory before using it to make sure that it does not in any way reduce ground clearance or cornering clearance, limit suspension travel,

steering travel or control operation, or obscure lights or reflectors.

- Accessories fitted to the handlebar or the front fork area can create instability due to improper weight distribution or aerodynamic changes. If accessories are added to the handlebar or front fork area, they must be as lightweight as possible and should be kept to a minimum.
- Bulky or large accessories may seriously affect the stability of the motorcycle due to aerodynamic effects. Wind may attempt to lift the motorcycle, or the motorcycle may become unstable in cross winds. These accessories may also cause instability when passing or being passed by large vehicles.
- Certain accessories can displace the operator from his or her normal riding position. This improper position limits the freedom of movement of the

# Safety information

---

1

operator and may limit control ability, therefore, such accessories are not recommended.

- Use caution when adding electrical accessories. If electrical accessories exceed the capacity of the motorcycle's electrical system, an electric failure could result, which could cause a dangerous loss of lights or engine power.

## **Aftermarket Tires and Rims**

The tires and rims that came with your motorcycle were designed to match the performance capabilities and to provide the best combination of handling, braking, and comfort. Other tires, rims, sizes, and combinations may not be appropriate. See page 7-19 for tire specifications and for information on servicing and replacing your tires.

## **Transporting the Motorcycle**

Be sure to observe following instructions before transporting the motorcycle in another vehicle.

- Remove all loose items from the motorcycle.
- Check that the fuel cock (if equipped) is in the off position and that there are no fuel leaks.
- Shift the transmission into gear (for models with a manual transmission).
- Secure the motorcycle with tie-downs or suitable straps that are attached to solid parts of the motorcycle, such as the frame or upper front fork triple clamp (and not, for example, to rubber-mounted handlebars or turn signals, or parts that could break). Choose the location for the straps carefully so the straps will not rub against painted surfaces during transport.
- The suspension should be compressed somewhat by the tie-downs, if possible, so that the motorcycle will not bounce excessively during transport.

## Left view

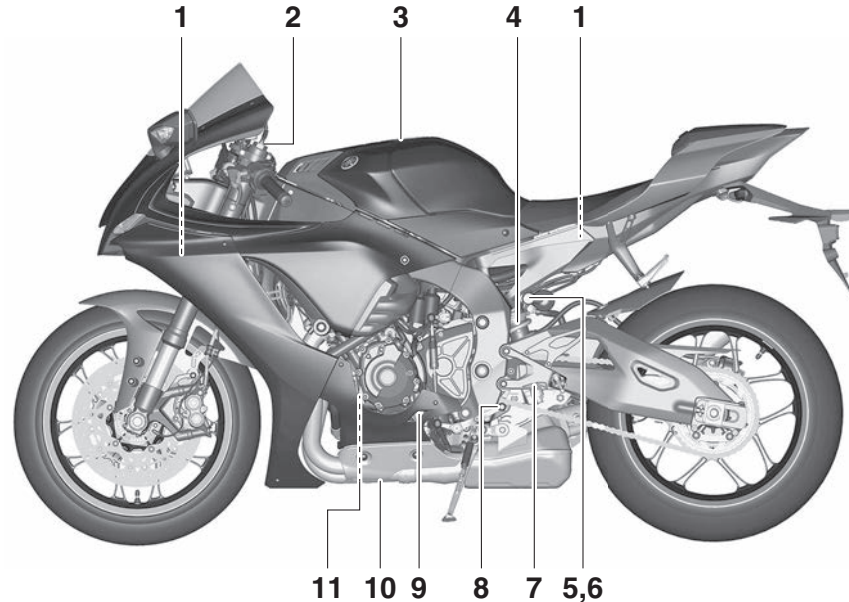

- 1. Fuses (page 7-35)
- 2. ERS coupler (YZF-R1M) (page 4-42)
- 3. Fuel tank cap (page 4-35)
- 4. Spring preload adjuster (page 4-45)
- 5. Fast compression damping force adjuster (YZF-R1) (page 4-45)
- 6. Slow compression damping force adjuster (YZF-R1) (page 4-45)
- 7. Rebound damping force adjuster (YZF-R1) (page 4-45)
- 8. Shift pedal (page 4-32)
- 9. Engine oil level check window (page 7-14)
- 10. Engine oil drain bolt (page 7-14)
- 11. Engine oil filter cartridge (page 7-14)

# Description

EAU10421

## Right view

2

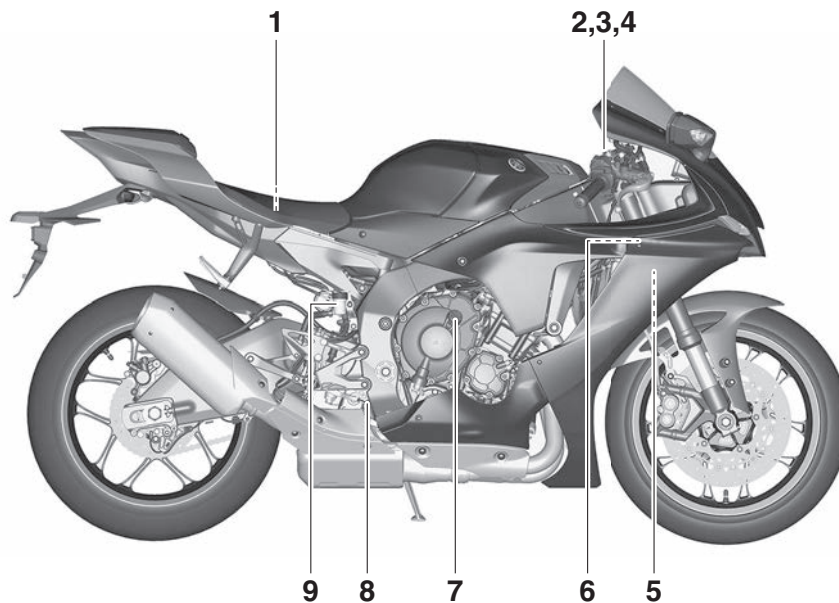

1. Battery (page 7-33)

2. Spring preload adjuster (page 4-42)

3. Rebound damping force adjuster (YZF-R1) (page 4-42)

4. Compression damping force adjuster (YZF-R1) (page 4-42)

5. Coolant reservoir (page 7-17)

6. Document storage space (page 4-41)

7. Engine oil filler cap (page 7-14)

8. Brake pedal (page 4-33)

9. Rear brake fluid reservoir (page 7-25)



## Controls and instruments

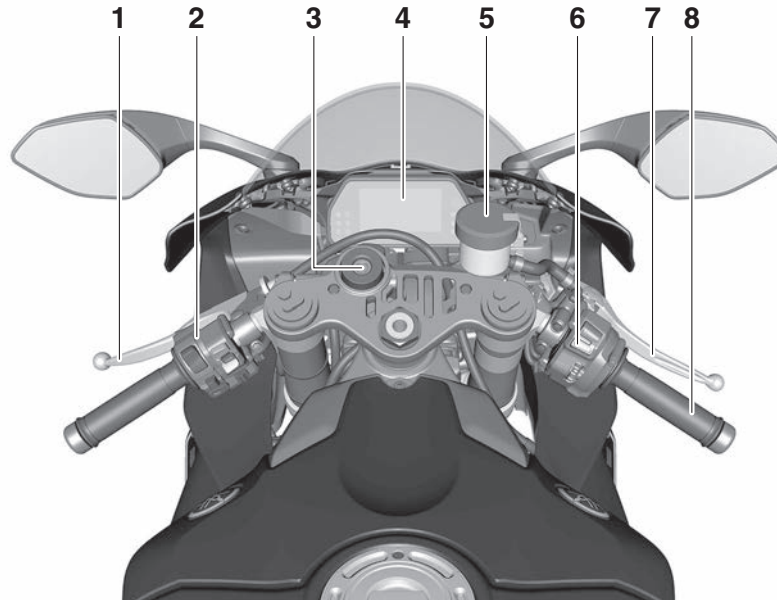

1. Clutch lever (page 4-32)
2. Left handlebar switches (page 4-3)
3. Main switch/steering lock (page 4-2)
4. Instrument panel (page 4-5, 4-9)
5. Front brake fluid reservoir (page 7-25)
6. Right handlebar switches (page 4-3)
7. Brake lever (page 4-33)
8. Throttle grip

# Special features

3

## YRC (Yamaha Ride Control)

EAU6629B

Yamaha Ride Control is a system that incorporates numerous sensors and controls to support an improved riding experience. The vehicle senses and can react to forces along the longitudinal (front-to-back), lateral (left-to-right), and vertical (up-and-down) axes. Lean angle and G-force accelerations are also detected. This information is processed multiple times a second and the related physical systems are automatically adjusted as necessary. The following functions represent individual YRC items which can be turned on/off or adjusted to suit various riders and riding conditions. For setting details, see pages 4-11 and 4-16.

EWA18221

### **WARNING**

**The Yamaha Ride Control (YRC) system is not a substitute for the use of proper riding techniques or the expertise of the operator. This system cannot prevent loss of control caused by rider errors such as traveling faster than warranted by road and traffic conditions, including loss**

**of traction due to excessive speed when entering turns, when accelerating hard at a sharp lean angle, or while braking, and it cannot prevent front wheel slip or front wheel lift. As with any motorcycle, always ride within in your limits, be aware of surrounding conditions, and ride appropriately for those conditions. Become thoroughly familiar with the way the motorcycle handles with various YRC settings before attempting more advanced maneuvers.**

## PWR

The power delivery mode system consists of four different control maps which regulate throttle valve opening in relation to the degree of throttle grip operation, thus providing you with a selection of modes to fit your preferences and the riding environment.

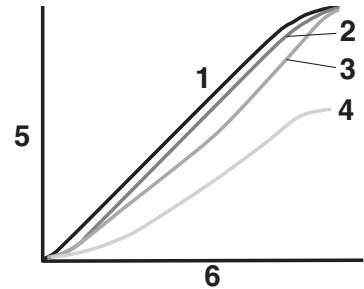

1. PWR 1
2. PWR 2
3. PWR 3
4. PWR 4
5. Throttle valve opening
6. Throttle grip operation

## TCS

The traction control system helps maintain traction when accelerating. If sensors detect that the rear wheel is starting to slip (uncontrolled spinning), the traction control system assists by regulating engine power as needed until traction is restored. The traction control system indicator/warning light flashes to let the rider know that traction control has engaged.

EWA15433

ECA16801

This traction control system automatically adjusts according to the vehicle's lean angle. To maximize acceleration, when the vehicle is upright a less amount of traction control is applied. When cornering, a greater amount of traction control is applied.



- TIP** \_\_\_\_\_
- The traction control system may engage when the vehicle travels over a bump.
  - You may notice slight changes in engine and exhaust sounds when the traction control or other YRC systems engage.
  - When TCS is turned off, SCS, LCS, and LIF are also turned off automatically.

**! WARNING** \_\_\_\_\_

**The traction control system is not a substitute for riding appropriately for the conditions. Traction control cannot prevent loss of traction due to excessive speed when entering turns, when accelerating hard at a sharp lean angle, or while braking, and cannot prevent front wheel slipping. As with any vehicle, approach surfaces that may be slippery with caution and avoid especially slippery surfaces.**

When the key is turned to “ON”, the traction control system automatically turns on. The traction control system can be turned on or off manually only when the key is in the “ON” position and the motorcycle is stopped.

**TIP** \_\_\_\_\_

Turn the traction control system off to help free the rear wheel if the motorcycle gets stuck in mud, sand, or other soft surfaces.

**NOTICE** \_\_\_\_\_

**Use only the specified tires. (See page 7-19.) Using different sized tires will prevent the traction control system from controlling tire rotation accurately.**

**SCS**

The slide control system regulates engine power output when a sideward slide is detected in the rear wheel. It adjusts power output based on data from the IMU. This system supports the TCS to contribute to a smoother ride.

**EBM**

The engine brake management system reduces engine torque when decelerating. The fuel injection, ignition timing, and electronic throttle valve are electronically adjusted by the ECU. There are 3 settings to suit the track, riding conditions, or your personal preference.

# Special features

3

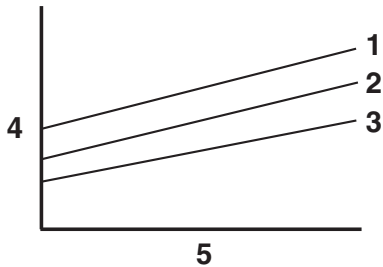

1. EBM1
2. EBM2
3. EBM3
4. Engine brake force
5. Engine r/min

EWA20880

## **WARNING**

**Make sure the engine has sufficiently slowed before shifting to a lower gear. Engaging a lower gear when the engine speed is too high could make the rear wheel lose traction. This could cause loss of control, an accident and injury. It could also cause engine or drivetrain damage.**

## LCS

The launch control system helps the rider achieve smooth and swift launches from the starting grid. It keeps engine speed from rising when the throttle grip is fully turned. The LCS regulates engine power output in conjunction with the TCS and LIF systems for optimal traction and reduced wheel lift.

ECA22950

## **NOTICE**

**Even when using LCS, the clutch lever must be released gradually to avoid clutch damage.**

## TIP

LCS is intended for track use only.

## QSS

The quick shift system allows for clutch lever-less, electronically-assisted shifting. When the sensor on the shift rod detects the appropriate motion in the shift pedal, engine power output is momentarily adjusted to allow for the gear change to occur.

QSS does not operate when the clutch lever is pulled, therefore normal shifting can be done even when QSS is set to on. Check the QS indicator for current status and usability information.

QSS usability	Indicator	Situation
Upshifting OK	QS ▲ ▽	Accelerating
Downshifting OK	QS ▲ ▽	Decelerating
QSS cannot be used	QS ▲ ▽	Stopped
QSS turned off	QS □	Turned off

## Upshifting conditions

- Vehicle speed of at least 20 km/h (12 mi/h)
- Engine speed of at least 2200 r/min
- Accelerating (open throttle)

## Downshifting conditions

- Vehicle speed of at least 20 km/h (12 mi/h)
- Engine speed of at least 2000 r/min
- Engine speed sufficiently away from red zone

- Decelerating and throttle fully-closed

## TIP

- QS ▲ and QS ▼ can be individually set.
- Shifting into or out of neutral must be done using the clutch lever.

## LIF

The lift control system reduces the rate at which the front wheel will continue to rise during extreme acceleration, such as during starts or out-of-corner exits. When front-wheel lift is detected, engine power is regulated to slow front-wheel lift while still providing good acceleration.

## BC

The brake control system regulates hydraulic brake pressure for the front and rear wheels when the brakes are applied and wheel lock is detected. This system has two settings.

BC1 is standard ABS, which adjusts brake pressure based on vehicle speed and wheel speed data. BC1 is designed to engage and maximize braking when the vehicle is upright. BC2 uses additional data from the IMU to regulate applied brake power when cornering to suppress lateral wheel slip.

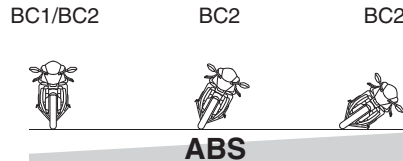

EWA20891

## **⚠ WARNING**

**The brake control system is not a substitute for the use of proper riding and braking techniques. The brake control system cannot prevent all loss of traction due to over-**

**braking from excessive speed, or lateral wheel slip when braking on slippery surfaces.**

## ERS (YZF-R1M)

The electronic racing suspension by ÖHLINS® features OBTi (objective-based tuning interface) for simplified, situation-focused setting changes of the automatic suspension control modes. In addition, there are manual modes which offer a finely-tuneable traditional suspension set-up. The ERS system is controlled by the SCU which can adjust the front and rear suspension's compression stroke and rebound stroke damping forces independently. The automatic modes will adjust suspension damping forces based on running conditions.

# Special features

---

EAU66313

## Glossary

ABS - Anti-lock Brake System

ABS ECU - Anti-lock Brake System

Electronic Control Unit

BC - Brake Control

CCU - Communication Control Unit

EBM - Engine Brake Management

ECU - Engine Control Unit

ERS - Electronic Racing Suspension

GPS - Global Positioning System

IMU - Inertial Measurement Unit

LCS - Launch Control System

LIF - Lift Control System

PWR - Power delivery mode

QS - Quick Shift

QSS - Quick Shift System

SC - Stability Control

SCS - Slide Control System

SCU - Suspension Control Unit

TCS - Traction Control System

YRC - Yamaha Ride Control

3

## YRC functions visual guide

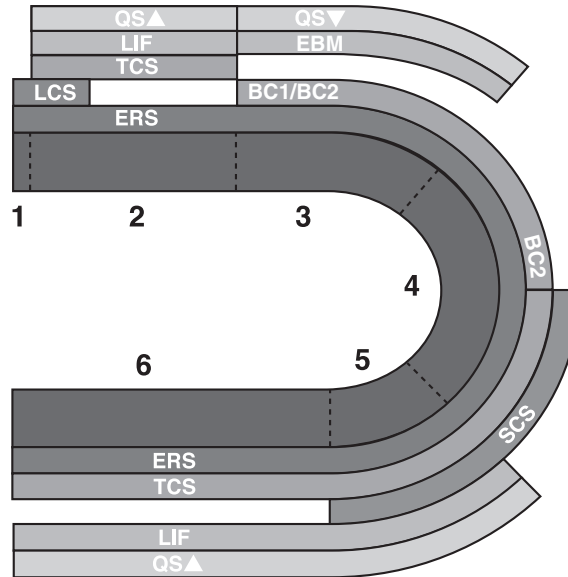

1. Start
2. Acceleration
3. Braking
4. Apex
5. Exit
6. Straightaway

# Instrument and control functions

## Immobilizer system

EAU1097A

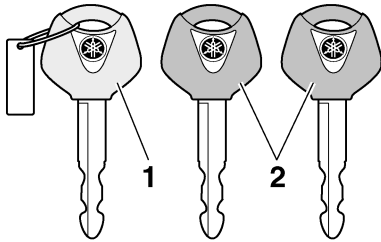

1. Code re-registering key (red bow)
2. Standard keys (black bow)

This vehicle is equipped with an immobilizer system to help prevent theft by re-registering codes in the standard keys. This system consists of the following:

- a code re-registering key
- two standard keys
- a transponder (in each key)
- an immobilizer unit (on the vehicle)
- an ECU (on the vehicle)
- a system indicator light (page 4-7)

### About the keys

The code re-registering key acts like a master key. It is used to register codes in each standard key. Store the code re-registering key in a safe place. Use a standard key for daily operation.

When key replacement or re-registering is necessary, bring the vehicle and the master key along with any remaining standard keys to a Yamaha dealer to have them re-registered.

### TIP

- Keep the standard keys as well as keys of other immobilizer systems away from the code re-registering key.
- Keep other immobilizer system keys away from the main switch as they may cause signal interference.

ECA11823

### NOTICE

**DO NOT LOSE THE CODE RE-REGISTERING KEY! CONTACT YOUR DEALER IMMEDIATELY IF IT IS LOST! If the code re-registering key is lost, the existing standard keys can still be used to start the vehicle.**

However, registering a new standard key is impossible. If all keys have been lost or damaged, the entire immobilizer system must be replaced. Therefore, handle the keys carefully.

- Do not submerge in water.
- Do not expose to high temperatures.
- Do not place near magnets.
- Do not place near items that transmit electrical signals.
- Do not handle roughly.
- Do not grind or alter.
- Do not disassemble.
- Do not put two keys of any immobilizer system on the same key ring.



## Main switch/steering lock

EAU10474

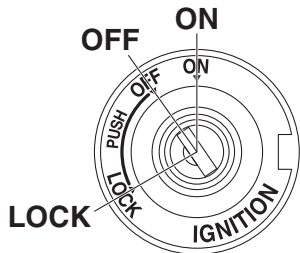

The main switch/steering lock controls the ignition and lighting systems, and is used to lock the steering. The various positions are described below.

### TIP

Be sure to use the standard key (black bow) for regular use of the vehicle. To minimize the risk of losing the code re-registering key (red bow), keep it in a safe place and only use it for code re-registering.

### ON

All electrical circuits are supplied with power and the vehicle lights are turned on. The engine can be started. The key cannot be removed.

### TIP

- The headlight(s) will turn on when the engine is started.
- To prevent battery drain, do not leave the key in the on position without the engine running.

### OFF

All electrical systems are off. The key can be removed.

### **⚠ WARNING**

**Never turn the key to "OFF" or "LOCK" while the vehicle is moving. Otherwise the electrical systems will be switched off, which may result in loss of control or an accident.**

EAU84031

### LOCK

The steering is locked and all electrical systems are off. The key can be removed.

### To lock the steering

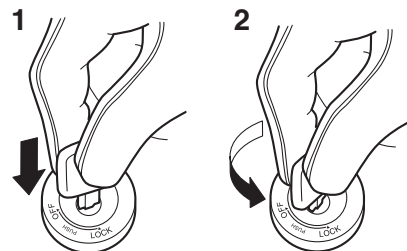

1. Push.
2. Turn.

1. Turn the handlebars all the way to the left.
2. With the key in the "OFF" position, push the key in and turn it to "LOCK".
3. Remove the key.

# Instrument and control functions

**TIP** \_\_\_\_\_  
If the steering will not lock, try turning the handlebars back to the right slightly.

## To unlock the steering

4

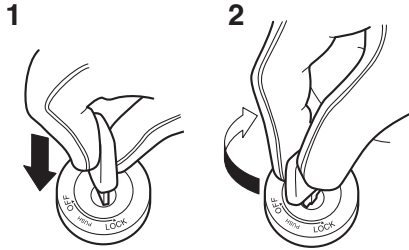

Push the key in and turn it to “OFF”.

## Handlebar switches

EAU66055

### Left

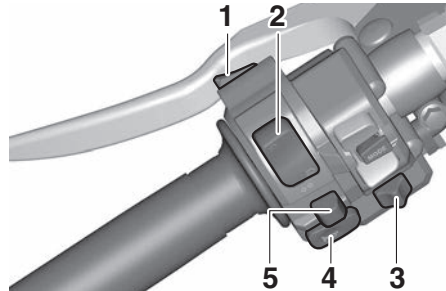

1. Pass/LAP switch “ $\equiv$  D / LAP”
2. Dimmer switch “ $\equiv$  D /  $\equiv$  D”
3. Hazard switch “OFF /  $\triangle$ ”
4. Horn switch “ $\text{HORN}$ ”
5. Turn signal switch “ $\leftarrow$  /  $\rightarrow$ ”

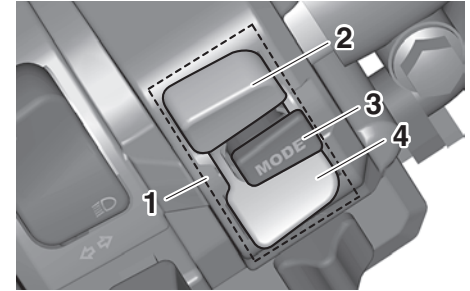

1. Mode switch “MODE”
2. Up button
3. Center button
4. Down button

### Right

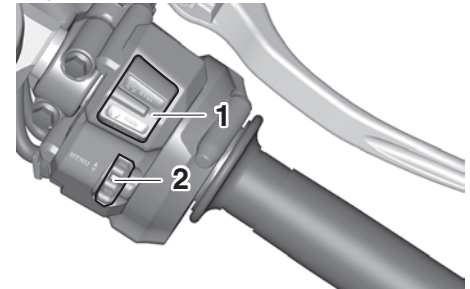

1. Stop/Run/Start switch “ $\text{STOP}$  /  $\text{RUN}$  /  $\text{START}$ ”
2. Wheel switch “MENU  $\blacklozenge$ ”



## Pass/LAP switch “/LAP”

EAU66091

Press this switch to flash the headlights and to mark the start of each lap when using the lap timer.

## Dimmer switch “/

EAU79872



Set this switch to “” for the high beam and to “” for the low beam.

## TIP

When the switch is set to low beam, only the left headlight comes on. When the switch is set to high beam, both headlights come on.

## Turn signal switch “/

EAU66040

To signal a right-hand turn, push this switch to “”. To signal a left-hand turn, push this switch to “”. When released, the switch returns to the center position. To cancel the turn signal lights, push the switch in after it has returned to the center position.



## Horn switch “”

EAU66030

Press this switch to sound the horn.

## Stop/Run/Start switch “/ /

EAU66060

To crank the engine with the starter, set this switch to “”, and then push the switch down towards “”. See page 6-2 for starting instructions prior to starting the engine.

Set this switch to “” to stop the engine in case of an emergency, such as when the vehicle overturns or when the throttle cable is stuck.

## Hazard switch “OFF/

EAU88272

Use this switch to turn on the hazard lights (simultaneous flashing of all turn signal lights). The hazard lights are used in case of an emergency or to warn other drivers when your vehicle is stopped where it might be a traffic hazard.

The hazard lights can be turned on or off only when the key is in the “ON” position. You can turn the main switch to the “OFF” or “LOCK” position, and the hazard lights will continue to flash. To turn off the hazard lights, turn the main switch to the “ON” position and operate the hazard switch again.

## NOTICE

**Do not use the hazard lights for an extended length of time with the engine not running, otherwise the battery may discharge.**

## Mode switch “MODE”

EAU88400

Use the mode switch to change YRC modes or edit the PWR, TCS, SCS, and EBM settings from the main screen. This switch has three buttons.

**Up button** - push this button to change the selected YRC setting upward.

**Center button** - push this button to scroll left to right among the MODE, PWR, TCS, SCS, and EBM items.

**Down button** - push this button to change the selected YRC setting downward.

## TIP

- The center button is also used to activate the launch control system. When the LCS icon is grey, push and hold the center button.

# Instrument and control functions

The LCS icon will flash and turn white when the system has been activated.

- The traction control system can only be turned off from the main screen. Select TCS with the center button, then push and hold the up button until TCS OFF is displayed. To turn the traction control system back on, use the down button.
- When TCS has been turned off, the SCS, LCS, and LIF systems are also turned off for all YRC modes.
- See “YRC Setting” on page 4-16 for more information on how to customize YRC modes and adjust YRC item setting levels.

When the display has been changed to the MENU screen, use the wheel switch to navigate the setting modules and make setting changes.

Operate the wheel switch as follows.

**Rotate up** - rotate the wheel upward to scroll up/left or increase a setting value.

**Rotate down** - rotate the wheel downward to scroll down/right or decrease a setting value.

**Short push** - briefly press the switch inward to make and confirm selections.

**Long push** - press the switch inward for one second to reset an information display item or to access and exit the MENU screen.

## TIP

- See page 4-9 for more information on the main screen and its functions.
- See page 4-15 for more information on the MENU screen and how to make setting changes.

4

## Wheel switch “MENU”

EAU66100









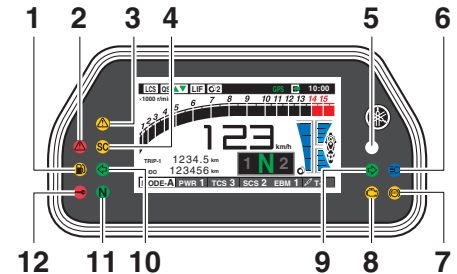



When the main screen is set to STREET MODE, use the wheel switch to scroll and reset the information display items.

When the main screen is set to TRACK MODE, use the wheel switch to scroll and reset the information display items and to activate the lap timer.

EAU4939H

## Indicator lights and warning lights



1. Fuel level warning light “”
2. Oil pressure and Coolant temperature warning light “”
3. Auxiliary system warning light “”
4. Stability control indicator light “”
5. Shift indicator light “”
6. High beam indicator light “”
7. ABS warning light “”
8. Malfunction indicator light “”
9. Right turn signal indicator light “”
10. Left turn signal indicator light “”
11. Neutral indicator light “”
12. Immobilizer system indicator light “”

## Turn signal indicator lights “” and “”

Each indicator light will flash when its corresponding turn signal lights are flashing.

## Neutral indicator light “”

This indicator light comes on when the transmission is in the neutral position.

## High beam indicator light “”

This indicator light comes on when the high beam of the headlight is switched on.

## Fuel level warning light “”

This warning light comes on when the fuel level drops below approximately 3.0 L (0.79 US gal, 0.66 Imp.gal). When this occurs, refuel as soon as possible. The electrical circuit of the warning light can be checked by turning the vehicle on. The warning light should come on for a few seconds, and then go off.

### TIP

If the warning light does not come on at all, remains on after refueling, or if the warning light flashes repeatedly, have a Yamaha dealer check the vehicle.

## Malfunction indicator light (MIL) “”

This light comes on or flashes if a problem is detected in the engine or other vehicle control system. If this occurs, have a Yamaha dealer check the on-board diagnostic system. The electrical circuit of the warning light can be checked by vehicle power on. The light should come on for a few seconds, and then go off. If the light does not come on initially when the vehicle power on, or if the light remains on, have a Yamaha dealer check the vehicle.

### NOTICE

**If the MIL starts flashing, reduce engine speed to prevent exhaust system damage.**

### TIP

The engine is sensitively controlled for the on-board diagnostic system to detect deterioration and malfunction of the emission control system. Due to this specification, the MIL may come on or flash for vehicle modifications, lack of maintenance, or excessive or improper use of the motorcycle. To prevent this, observe these precautions.

- Do not attempt to modify the software of the engine control unit.
- Do not add any electrical accessories that interfere with engine control.
- Do not use aftermarket accessories or parts such as suspension, spark plugs, injectors, exhaust system, etc.
- Do not change drivetrain specifications (chain, sprockets, wheels, tires, etc.).
- Do not remove or alter the O2 sensor, air induction system, or exhaust parts (catalysts or EXUP, etc.).
- Maintain proper drive chain.

# Instrument and control functions

4

- Maintain correct tire pressure.
- Maintain proper brake pedal height to prevent rear brake from dragging.
- Do not operate the vehicle in an extreme manner. For example, repeated or excessive opening and closing of the throttle, racing, burnouts, wheelies, extended half-clutch use, etc.

## ABS warning light “”

EAU88342

In normal operation, the ABS warning light comes on when the vehicle is turned on, and goes off after traveling at a speed of 10 km/h (6 mi/h) or higher.

### TIP

If the warning light does not work as described above, or if the warning light comes on while riding, the ABS may not work correctly. Have a Yamaha dealer check the vehicle as soon as possible.



EWA16043

**If the ABS warning light does not turn off after reaching 10 km/h (6 mi/h), or if the warning light comes on while riding:**

- Use extra caution to avoid possible wheel lock during emergency braking.
- Have a Yamaha dealer check the vehicle as soon as possible.

## Shift indicator light “”

EAU67433

This indicator light comes on when it is time to shift to the next higher gear. The engine speeds at which it comes on or goes off can be adjusted. (See page 4-25.)

### TIP

When the vehicle is turned on, this light should come on for a few seconds and then go off. If the light does not come on, or if the light remains on, have a Yamaha dealer check the vehicle.

## Immobilizer system indicator light “”

EAU88350

When the main switch is turned off and 30 seconds have passed, the indicator light will flash steadily to indicate the immobilizer system is enabled. After 24 hours have passed, the indicator light will stop flashing, however the immobilizer system is still enabled.

### TIP

When the vehicle is turned on, this light should come on for a few seconds and then go off. If the light does not come on, or if the light remains on, have a Yamaha dealer check the vehicle.

## Transponder interference

If the immobilizer system indicator light flashes in the pattern, slowly 5 times then quickly 2 times, this could be caused by transponder interference. If this occurs, try the following.

1. Make sure there are no other immobilizer keys close to the main switch.
2. Use the code re-registering key to start the engine.

3. If the engine starts, turn it off, and try starting the engine with the standard keys.
4. If one or both of the standard keys do not start the engine, take the vehicle and all 3 keys to a Yamaha dealer to have the standard keys re-registered.

## Stability control indicator light “SC” <sup>EAU88390</sup>

This indicator light comes on when the TCS, SCS, or LIF systems have engaged. It will also come on if the TCS is set to “OFF” or if the TCS system becomes disabled while riding.

### TIP \_\_\_\_\_

When the vehicle is turned on, this light should come on for a few seconds and then go off. If the light does not come on, or if the light remains on, have a Yamaha dealer check the vehicle.

## Oil pressure and Coolant temperature warning light “” <sup>EAU88362</sup>

This warning light comes on if the engine oil pressure is low or if the coolant temperature is high. If this occurs, stop the engine immediately.

### TIP \_\_\_\_\_

- When the vehicle is first turned on, this light should come on until the engine is started.
- If a malfunction is detected, this light will come on and the oil pressure icon will flash.

### NOTICE \_\_\_\_\_ <sup>ECA22441</sup>

**If the oil pressure and coolant warning light does not go off after starting the engine or if it comes on while the engine is running, stop the vehicle and engine immediately.**

- **If the engine is overheating, the coolant temperature warning icon will come on. Let the engine cool. Check the coolant level (see page 7-40).**

- **If the engine oil pressure is low, the oil pressure warning icon will come on. Check the oil level (see page 7-14).**
- **If the warning light remains on after letting the engine cool and confirming the proper oil level, have a Yamaha dealer check the vehicle. Do not continue to operate the vehicle!**

## Auxiliary system warning light “” <sup>EAU88370</sup>

This warning light comes on if a problem is detected in a non-engine-related system.

### TIP \_\_\_\_\_

When the vehicle is turned on, this light should come on for a few seconds and then go off. Otherwise, have a Yamaha dealer check the vehicle.

# Instrument and control functions

EAU79285

## Display

The display has two different main screen display modes, STREET MODE and TRACK MODE. Most of the functions are viewable in either mode, but the layout differs slightly. The following items can be found on the display.

- Speedometer
- Tachometer
- Information display
- Transmission gear display
- Front brake pressure indicator
- Acceleration indicator
- YRC setting display
- YRC setting display
- YRC setting display
- ERS indicator (YZF-R1M)
- GPS indicator (CCU-equipped models)
- Logging indicator (CCU-equipped models)
- Clock
- Revolution peak hold indicator
- Lap timer
- Various warning icons
- Error mode warning “Err”

## TIP

This model uses a thin-film-transistor liquid-crystal display (TFT LCD) for good contrast and readability in various lighting conditions. However, due to the nature of this technology, it is normal for a small number of pixels to be inactive.

## STREET MODE

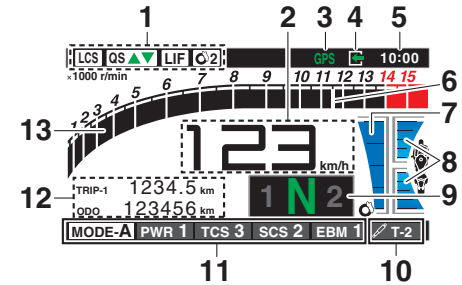

1. YRC items LCS/QS/LIF/BC
2. Speedometer
3. GPS indicator (CCU-equipped models)
4. Logging indicator (CCU-equipped models)
5. Clock
6. Revolution peak hold indicator
7. Front brake pressure indicator
8. Acceleration indicator
9. Transmission gear display
10. ERS indicator (YZF-R1M)
11. YRC items MODE/PWR/TCS/SCS/EBM
12. Information display
13. Tachometer



## TRACK MODE

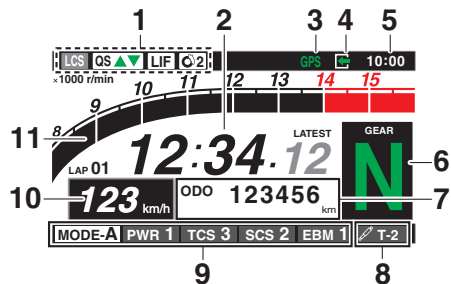

1. YRC items LCS/QS/LIF/BC
2. Lap timer
3. GPS indicator (CCU-equipped models)
4. Logging indicator (CCU-equipped models)
5. Clock
6. Transmission gear display
7. Information display
8. ERS indicator (YZF-R1M)
9. YRC items MODE/PWR/TCS/SCS/EBM
10. Speedometer
11. Tachometer

EWA18210



## WARNING

**Stop the vehicle before making any setting changes. Changing settings while riding can distract the operator and increase the risk of an accident.**

## Speedometer

The speedometer shows the vehicle's traveling speed.

## TIP

The display can be switched between kilometers and miles. See "Unit" on page 4-24.

## Tachometer

The tachometer shows the engine speed, as measured by the rotational velocity of the crankshaft, in revolutions per minute (r/min).

## TIP

- In TRACK MODE, the tachometer starts at 8000 r/min.
- In STREET MODE, the tachometer can be color-adjusted and has a revolution peak hold indicator which can be turned on or off.

## NOTICE

**Do not operate the engine in the tachometer red zone.**

**Red zone: 14000 r/min and above**

## Information display

This section of the main screen is used to show additional riding related information such as air and coolant temperature readings, tripmeters, and fuel consumption statistics. The information display items can be set into four groups via the MENU screen.

The information display items are:

A.TEMP: air temperature

C.TEMP: coolant temperature

TRIP-1: tripmeter 1

TRIP-2: tripmeter 2

F-TRIP: fuel tripmeter

ODO: odometer

FUEL CON: the amount of fuel consumed

FUEL AVG: average fuel consumption

CRNT FUEL: current fuel consumption

## TIP

- ODO will lock at 999999 and cannot be reset.
- TRIP-1 and TRIP-2 will reset to 0 and begin counting again after 9999.9 has been reached.

# Instrument and control functions

---

4

- When the fuel tank reserve level has been reached, F-TRIP appears automatically and begins recording distance traveled from that point.
  - After refueling and traveling some distance, F-TRIP will automatically disappear.
  - See “Unit” on page 4-24 to change the fuel consumption units.
  - The air temperature displayed may vary from the actual ambient temperature.
  - In TRACK MODE, information display items FASTEST (fastest lap time) and AVERAGE (average lap time) are also available.
2. Short push the wheel switch and the item will flash for five seconds. (For STREET MODE, if both items are resettable items, the top item will flash first. Scroll down to select the bottom item.)
  3. While the item is flashing, press and hold the wheel switch for one second.

## Transmission gear display

This shows which gear the transmission is in. This model has 6 gears and a neutral position. The neutral position is indicated by the neutral indicator light “N” and by the transmission gear display “N”.

## Front brake pressure indicator

This shows how much braking power is being applied to the front brakes.

## Acceleration indicator

This shows the vehicle’s forward acceleration and deceleration forces.

## Revolution peak hold indicator

This small bar momentarily appears within the tachometer to mark the most recent peak engine speed.

## YRC items

### MODE/PWR/TCS/SCS/EBM

The current MODE (YRC mode) and its related PWR, TCS, SCS, and EBM settings are shown here.

The individual settings for YRC items PWR, TCS, SCS, LCS, QSS, LIF, EBM, and BC can be organized into four groups and set independently for each group. These groups of settings are the YRC modes MODE-A, MODE-B, MODE-C, and MODE-D. Use the mode switch to change YRC modes or make YRC item setting changes from the main screen.

## TIP

The YRC modes come preset from the factory for different riding conditions. When using the factory presets, the suggested YRC modes are as follows.  
MODE-A: suitable for track riding  
MODE-B: softer track-riding setting  
MODE-C: suitable for road use

---

TRIP-1, TRIP-2, F-TRIP, FUEL CON, and FUEL AVE items can be individually reset.

## To reset information display items

1. Use the wheel switch to scroll through the display items until the item you want to reset appears.

# Instrument and control functions

MODE-D: street use or rainy weather

## To change YRC modes or make setting changes

1. Push the mode switch center button to scroll left to right and highlight the item you want to adjust.

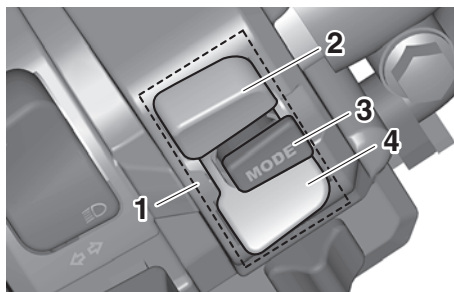

1. Mode switch “MODE”
2. Up button
3. Center button
4. Down button

2. Use the mode switch up button or down button to change the selected item value (vertical scrolling is not possible).

## TIP

- When the malfunction indicator light is on, YRC settings cannot be adjusted.
- When a YRC function is actively engaged that item cannot be adjusted. For example, when decelerating EBM cannot be adjusted.
- When a YRC item is highlighted but cannot be adjusted, the YRC item box will return to black.

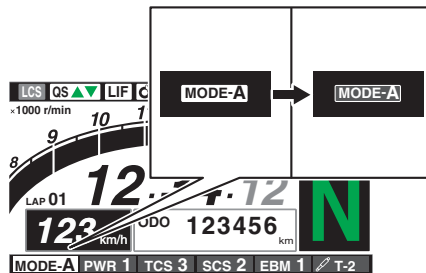

To turn off the traction control system, select TCS with the center button, then push and hold the up button until TCS OFF is displayed. To turn TCS back on, select TCS OFF and then press the down button (TCS will return to its previous setting).

## TIP

Turning off the traction control system will turn off the SCS, LCS, and LIF systems for all YRC modes.

## YRC items LCS/QS/LIF/BC

The on/off status of YRC items LCS, QSS, LIF, and BC is shown here. When any of these systems are registered (not set to OFF) for the currently selected YRC mode, its respective icon will appear.

When LCS is registered for the currently selected YRC mode, its icon will be grey. To activate the launch control system, press and hold the center button until the LCS icon stops flashing and turns white.

## TIP

LCS, QSS, LIF, and BC system setting levels can only be adjusted from the MENU screen.

## ERS indicator “ This icon shows the current ERS mode. (See “YRC Setting” on page 4-16 and “ERS” on page 4-19 to

# Instrument and control functions

change the registered ERS mode or adjust ERS setting levels.) If the ERS mode disappears from the ERS indicator (the icon turns blank), stop the vehicle and wait a few seconds until the mode reappears.

## TIP

4

- The suspension will remain fixed at its most recent settings until self-reset has completed.
- If the ERS indicator does not return to normal, have a Yamaha dealer inspect the vehicle.

## GPS indicator “GPS” (CCU-equipped models)

This icon comes on when a GPS unit is synched with your vehicle.

## Logging indicator “” (CCU-equipped models)

This icon comes on when vehicle data is being recorded via the logging function.

## Clock

The clock uses a 12-hour time system.

## Lap timer

This stopwatch function measures and records up to forty laps. On the main screen, the lap timer shows the current lap time and lap number (indicated by the LAP mark). Use the Pass/LAP switch to mark lap times. When a lap is completed, the lap timer will show the latest lap time (marked by the LATEST indicator) for five seconds.

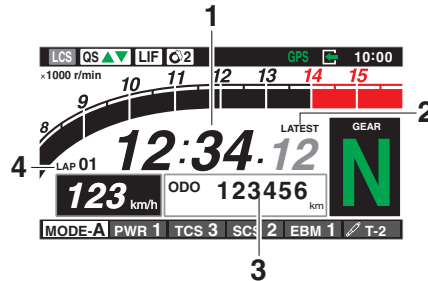

1. Lap time
2. Latest lap time indicator “LATEST”
3. Information display item
4. Lap number

## To use the lap timer

1. Short push the wheel switch. The information display item will flash for five seconds.

2. While the information display item is flashing, rotate the wheel switch upward. The lap timer will flash for five seconds.
3. While the lap timer is flashing, long push the wheel switch to activate the lap timer or stop the lap timer.
4. When the lap timer has been activated, press the Pass/LAP switch to start the lap timer.

## TIP

- The engine must be running to use the lap timer.
- Set the information display to FASTEST or AVERAGE for additional lap time information.
- Accessing the MENU screen will automatically stop the lap timer.
- Whenever the lap timer is stopped, the current lap will not be recorded.
- The lap time record can be viewed and reset from the MENU screen.

## Warning icons

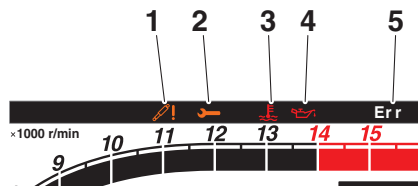

1. SCU trouble warning “”
2. Auxiliary system warning “”
3. Coolant temperature warning “”
4. Oil pressure warning “”
5. Error mode warning “Err”

When an error is detected, the following error-related warning icons will then be viewable.

### SCU trouble warning “” (YZF-R1M)

This icon appears if a problem is detected in the front or rear suspension.

### Auxiliary system warning “”

This icon appears if a problem is detected in a non-engine-related system.

### Coolant temperature warning “”

This icon appears if the coolant temperature reaches 117 °C (242 °F) or higher. Stop the vehicle and turn off the engine. Allow the engine to cool.

ECA10022

#### NOTICE

**Do not continue to operate the engine if it is overheating.**

### Oil pressure warning “”

This icon appears when the engine oil pressure is low. When the vehicle is first turned on, engine oil pressure has yet to build, so this icon will come on and stay on until the engine has been started.

#### TIP

If a malfunction is detected, the oil pressure warning icon will flash repeatedly.

ECA26410

#### NOTICE

**Do not continue to operate the engine if the oil pressure is low.**

### Error mode warning “Err”

When an internal error occurs (e.g., communication with a system controller has been cut off), the error mode warning will appear as follows.

“Err” and “” indicates an ECU error. “Err” and “” indicates an SCU error. “Err” only indicates an ABS ECU error.

#### TIP

Depending on the nature of the error, the display may not function properly and YRC settings may be impossible to change. Additionally, ABS may not function properly. Use extra care when braking and have a Yamaha dealer check the vehicle immediately.

# Instrument and control functions

EAU79297

## MENU screen

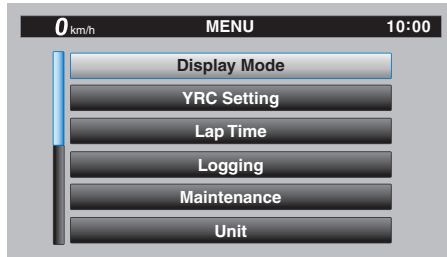

4

The MENU screen contains the following setting modules. Select a module to make related setting changes. Although some settings can be changed or reset via the main screen, the MENU screen offers access to all display and control settings.

Module	Description
Display Mode	Switch the main screen display between street and track modes.
YRC Setting	Adjust YRC settings (all models) and ERS settings (YZF-R1M).
Lap Time	View and reset lap times.
Logging	Turn vehicle information logging function on/off (CCU-equipped models).

Maintenance	View and reset three maintenance item intervals.
Unit	Set fuel consumption and distance units.
Wallpaper	Set background colors.
Shift Indicator	Turn the shift indicator on/off and adjust tachometer settings.
Display Setting	Set the multi-function display window items.
Brightness	Adjust screen brightness.
Clock	Adjust the clock.
All Reset	Return all settings to factory default settings.

### MENU access and operation

The following wheel switch operations are common operations for accessing, selecting, and moving within the MENU screen and its modules.

**Long push** - press and hold the wheel switch for one second to access the MENU screen or exit MENU entirely.

**Select** - rotate the wheel switch up or down to highlight the desired module or setting item and then short push the wheel switch (briefly press the wheel switch inward) to confirm the selection.

**Triangle mark** - certain setting screens have an upward pointing triangle mark item. Select the triangle mark to save setting changes made and exit that screen.

### TIP

- Should vehicle motion be detected, the screen will automatically exit MENU and change to the main screen.
- To ensure that the desired setting changes are saved, be sure to exit via the triangle mark. Simply performing a long push and exiting the MENU screen entirely may not save setting changes.

### “Display Mode”

There are two main screen display modes, STREET MODE and TRACK MODE.

#### To set the main screen display mode

1. From the MENU screen, select “Display Mode”.

# Instrument and control functions

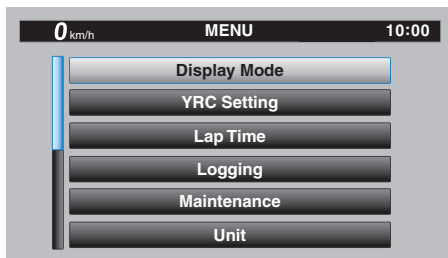

2. Select “STREET MODE” or “TRACK MODE” (or select the triangle mark to exit).

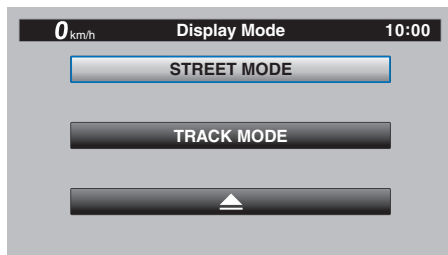

3. Long push the wheel switch to exit the MENU screen or use the wheel switch to select another module.

## “YRC Setting”

This module allows you to customize the four YRC modes MODE-A, MODE-B, MODE-C, and MODE-D by adjusting the setting levels (or on/off status as applicable) of YRC items PWR, TCS, SCS, LCS, QSS, LIF, EB, and BC. For YZF-R1M, you can select the ERS mode to be associated with each YRC mode, and also adjust the setting levels of the ERS modes.

### TIP

- TCS has 9 setting levels and ERS has 6 modes.
- Whenever there are more selections (setting levels or modes) available than can be shown on the screen at one time, a scroll bar will appear to notify you that additional selections are available by scrolling.

## PWR

Select PWR-1 for the most aggressive throttle response, PWR-2 and PWR-3 for smoother throttle grip/engine re-

sponse, and use PWR-4 for rainy days or whenever less engine power is desirable.

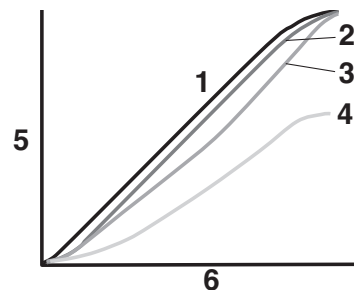

1. PWR 1
2. PWR 2
3. PWR 3
4. PWR 4
5. Throttle valve opening
6. Throttle grip operation

## TCS

This model uses a variable traction control system. For each setting level, the further the vehicle is leaned over, the greater the amount of traction control (system intervention) is applied. There are 9 setting levels available. Setting level 1 applies the least amount

# Instrument and control functions

of overall system intervention, while setting level 9 applies the greatest amount of overall traction control.

## TIP

- TCS can only be turned on or off via the main screen using the mode switch.
- When TCS has been turned off, TCS, SCS, LCS, and LIF will be set to OFF and cannot be adjusted. When TCS is turned on again, these related-traction control functions will return to their previous setting levels.

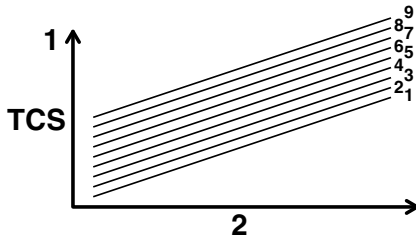

1. System intervention
2. Lean angle

## SCS

SCS can be set to OFF, 1, 2, and 3. OFF turns the slide control system off, setting level 1 provides the least amount of system intervention, and setting level 3 provides the greatest amount of system intervention.

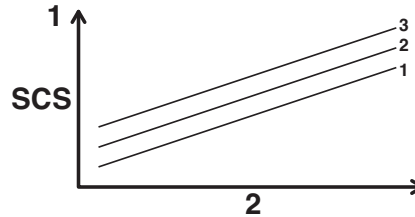

1. System intervention
2. Sideward slide

## LCS

LCS can be set to 1, 2, or OFF. Setting level 1 keeps engine speed from rising above 9000 r/min even when the throttle grip is fully turned. Setting level 2 keeps engine speed from rising above 8000 r/min. OFF disables the LCS function from the selected YRC mode

(the LCS icon will not appear and the launch control function cannot be activated).

When LCS has been set to level 1 or 2 for the selected YRC mode, the LCS indicator on the main screen will appear in a grey color to indicate that LCS is available. When the launch control system has been activated (made ready for use via the mode switch), the LCS indicator will turn white.

## TIP

LCS works in conjunction with the LIF system. LCS cannot be used if LIF is turned off.

## QSS

The quick shift system is divided into QS ▲ (upshift) and QS ▼ (downshift) sections. QS ▲ and QS ▼ are not linked and can be independently turned on or off.

QS ▲ can be set to 1, 2, or OFF. Setting level 1 is designed for maximum acceleration, while setting level 2 is designed to give smooth shifts at halfway or less throttle openings. OFF turns the



# Instrument and control functions

respective upshift or downshift function off, and the clutch lever must then be used when shifting in that direction.

## TIP

- Set QS ▲ to 1 for track or sporty riding.
- Set QS ▲ to 2 for touring or around town-riding.

## LIF

LIF can be set to 1, 2, 3, or OFF. Setting level 3 most strongly reduces wheel lift, and setting level 1 provides the least amount of system intervention. OFF turns LIF off and LCS will be disabled for the selected YRC mode.

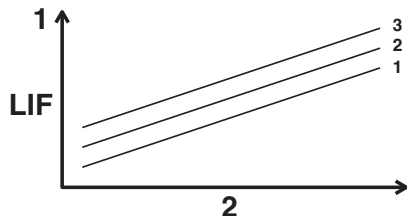

1. System intervention
2. Wheel lift

## EBM

This system has three settings. Level 1 provides the least amount of engine brake management intervention, and therefore the strongest amount of engine braking. Level 3 provides the greatest amount of engine brake management intervention, and therefore the least amount of engine braking.

## BC

Select BC1 when only standard ABS is desired. Select BC2 to have the brake control system regulate brake pressure while cornering to suppress lateral wheel slip.

## TIP

For skilled riders and when riding at the track, due to varying conditions BC2 brake system engagement may come on sooner than expected relative to your desired cornering speed or intended cornering line.

### To customize a YRC mode or adjust a YRC item

1. From the MENU screen, select “YRC Setting”.

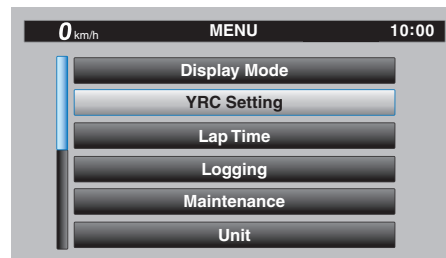

2. The “YRC Setting” screen is displayed, and the YRC mode box “YRC” is highlighted. Short push the wheel switch to enter the box and then select the YRC mode A, B, C, or D that you want to adjust.

# Instrument and control functions

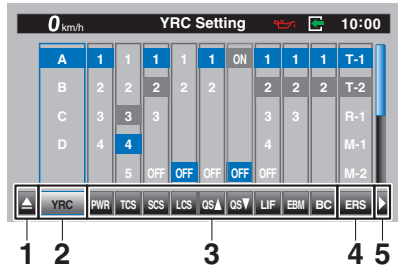

4

1. Triangle mark
2. YRC mode box
3. YRC item
4. ERS mode (YZF-R1M)
5. To ERS menu (YZF-R1M)

3. Select the YRC item PWR, TCS, SCS, LCS, QS ▲, QS ▼, LIF, EBM, BC, or ERS (YZF-R1M) that you want to adjust.

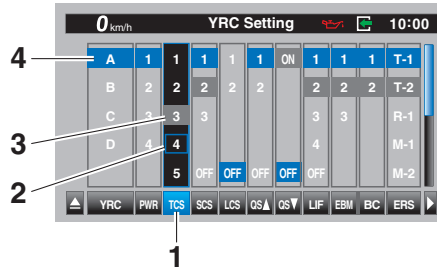

1. YRC item
2. Current level setting
3. Factory preset level
4. YRC mode

## TIP

- When a YRC item is selected, the current setting level is indicated by a blue-framed square and the factory preset level is indicated in a grey box.
- Factory preset levels vary depending on the selected YRC mode.

4. To customize other YRC modes or adjust individual YRC items, repeat from step 2. When finished, select the triangle mark on the far left to return to the MENU screen;

or for YZF-R1M select the “▶” mark to fine tune the ERS mode settings.

## ERS (YZF-R1M)

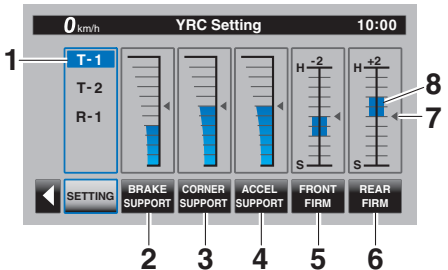

1. ERS mode
2. Braking support level
3. Cornering support level
4. Acceleration support level
5. Front overall damping level
6. Rear overall damping level
7. Factory preset level
8. Current level

The ERS consists of three semi-active automatic modes (T-1, T-2, and R-1) and three manual setting modes (M-1, M-2, and M-3). When an automatic mode is selected, the SCU will adjust the compression and rebound damp-

# Instrument and control functions

ing forces based on running conditions. For all modes and models, spring preload is physically adjusted by hand. (See pages 4-42 and 4-45.) For track modes T-1 and T-2, the following settings can be adjusted:

**BRAKE SUPPORT:** reduces nosedive (front-end pitch from braking)

**CORNER SUPPORT:** increases damping to absorb chassis fluctuations for smooth cornering. Reduce this setting for increased rear wheel grip.

**ACCEL SUPPORT:** reduces rear-end squat (rear-end pitch due to acceleration)

**FRONT FIRM:** hardens (H) or softens (S) overall damping of the front suspension

**REAR FIRM:** hardens (H) or softens (S) overall damping of the rear suspension

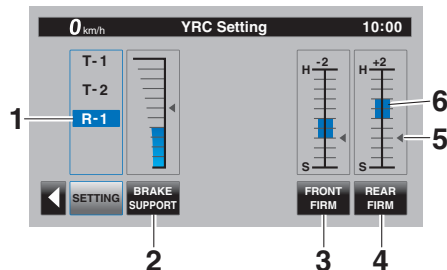

1. ERS mode
2. Braking support level
3. Front overall damping level
4. Rear overall damping level
5. Factory preset level
6. Current level

For the road mode R-1, the following settings can be adjusted:

**BRAKE SUPPORT:** reduces nosedive (front-end pitch from braking)

**FRONT FIRM:** hardens (H) or softens (S) overall damping of the front suspension

**REAR FIRM:** hardens (H) or softens (S) overall damping of the rear suspension

## TIP \_\_\_\_\_

- T-1 is preset for track use with racing slick tires.

- T-2 is preset for track use with street tires.
- R-1 is preset for road use with street tires.

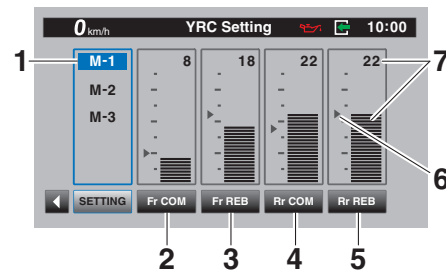

1. ERS mode
2. Front compression damping force
3. Front rebound damping force
4. Rear compression damping force
5. Rear rebound damping force
6. Factory preset level
7. Current level setting

For the manual setting modes M-1, M-2, and M-3, the following settings can be adjusted:

**Fr COM:** front compression damping

**Fr REB:** front rebound damping

**Rr COM:** rear compression damping

**Rr REB:** rear rebound damping

# Instrument and control functions

## TIP

- M-1 is preset for track use with racing slick tires.
- M-2 is preset for track use with street tires.
- M-3 is preset for street use with street tires.

4

## To adjust the ERS mode settings

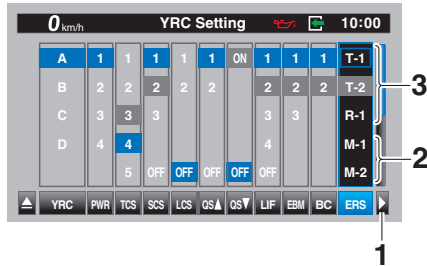

1. To ERS menu
2. Manual modes
3. Automatic modes

## TIP

The ERS setting menu is divided into automatic and manual setting modes, and the two types are accessed separately. Before moving to the ERS setting menu, make sure the current ERS

mode corresponds to the same type (automatic or manual) that you want to adjust.

1. Select the “▶” mark located to the right of ERS.
2. The display will change to the relevant suspension setting screen and the ERS mode selection box “SETTING” is highlighted. Short push the wheel switch to enter the box and select the ERS mode that you want to adjust.

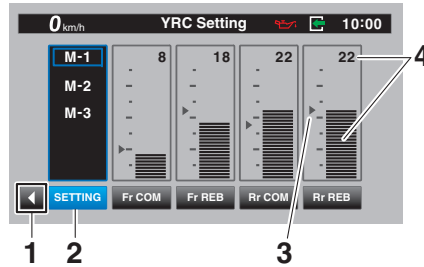

1. To YRC Setting menu
2. ERS mode selection box “SETTING”
3. Factory preset level
4. Current level setting

3. Select the suspension item that you want to adjust, and then rotate the wheel switch to adjust the setting level.

## TIP

All ERS modes regardless of type are independent. Offset level setting changes made in one mode are not transferred to another mode.

4. To adjust other ERS modes of the same type, repeat from step 1. To switch types or when finished, select the “◀” mark to return to the main “YRC Setting” menu.

## “Lap Time”

This module allows you to view and delete the lap time record. The fastest lap and the average lap time stored in the lap time record are displayed at the top of the screen. Use the wheel switch to scroll and see all lap times. The top three fastest laps will be highlighted in silver. Up to 40 laps can be stored in memory. If more than 40 laps are recorded, the oldest laps (starting from lap 1) will be overwritten.

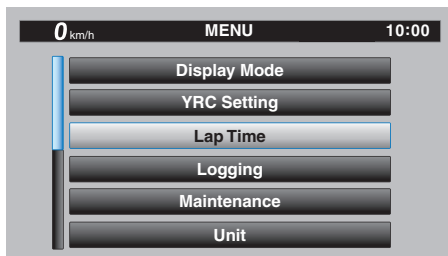

This module has two options. “Display” allows you to view the lap time record. “Reset” allows you to delete the lap time record data.

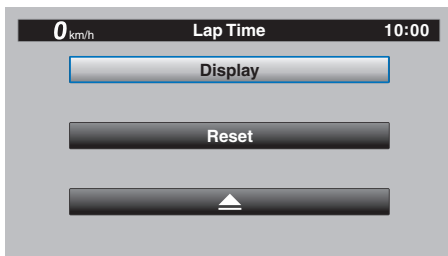

To view the lap time record data  
Select “Display”.

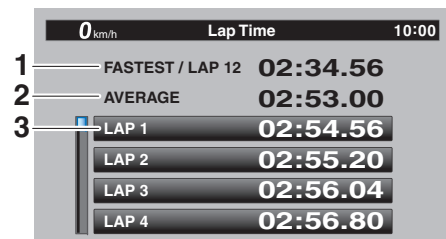
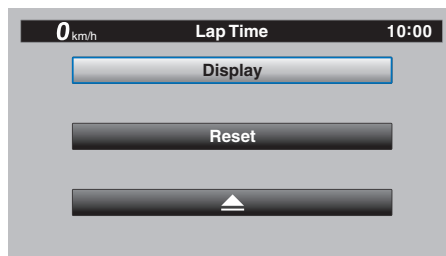

1. Fastest lap
2. Average lap time
3. Lap time record

To reset the lap time record data

1. Select “Reset”.

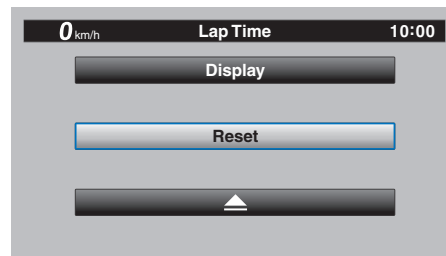

2. Select “YES” to delete all lap time data. (Select “NO” to exit and return to the previous screen without resetting the lap record.)

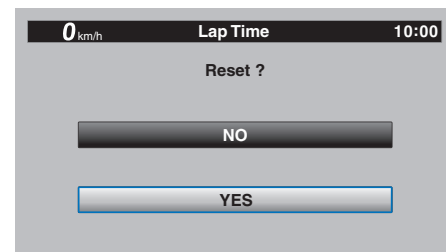

**“Logging” (CCU-equipped models)**

Vehicle and riding information can be recorded (logged) and this data can be accessed with a smart device (see “CCU” on page 4-39).

# Instrument and control functions

## To start and stop logging

1. From the MENU screen, select “Logging”.

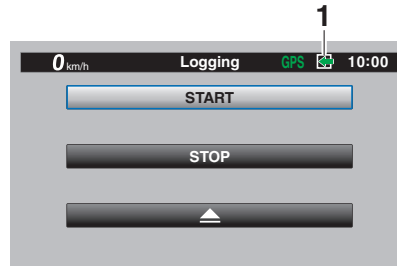
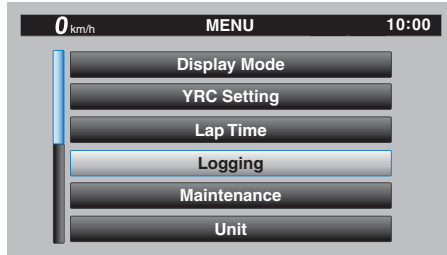

1. Logging indicator

3. To stop the “Logging” function, select “STOP” or turn the vehicle off.

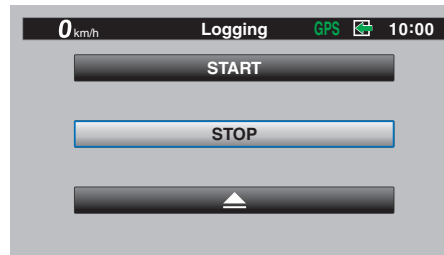

## TIP

The logging function will also start automatically when you start off.

## “Maintenance”

This module allows you to record distance traveled between engine oil changes (use the OIL item), and for two other items of your choice (use INTERVAL 1 and INTERVAL 2).

## To reset a maintenance item

1. From the MENU screen, select “Maintenance”.

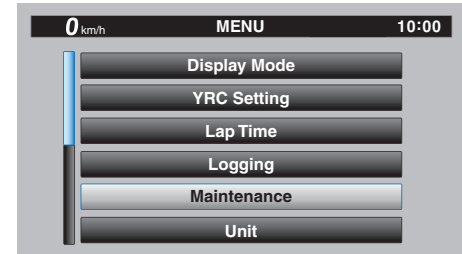

2. Select the item you want to reset.

## TIP

If a CCU is not installed, then the “Logging” module cannot be selected.

2. Select “START” to start logging.

## TIP

The arrow of the logging indicator is displayed in green.

# Instrument and control functions

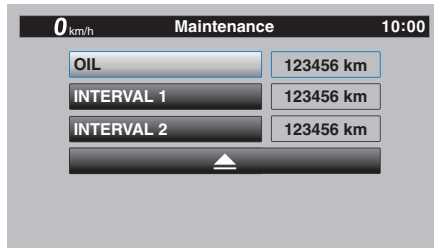

3. Long push the wheel switch to reset the item.

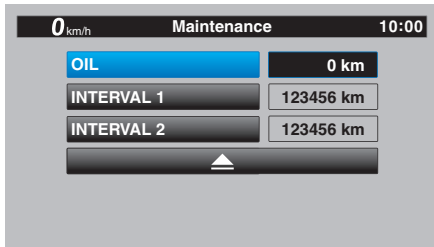

**TIP** \_\_\_\_\_  
Maintenance item names cannot be changed.

## “Unit”

This module allows you to switch the display between kilometers and miles.

When using kilometers, the fuel consumption units can be changed between km/L or L/100km. When using miles, MPG will be available.

## To set the distance or fuel consumption units

1. From the MENU screen, select “Unit”.

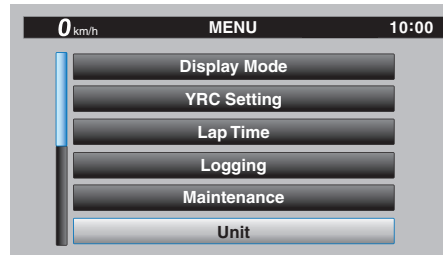

2. Select the distance or consumption unit item you want to adjust.

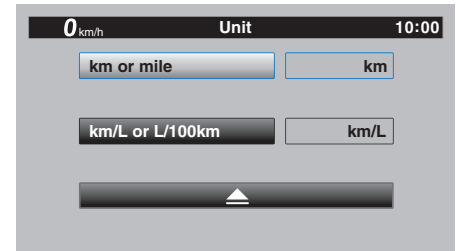

## **TIP** \_\_\_\_\_

When “km” is selected, “km/L” or “L/100km” can be set as the fuel consumption units. To set the fuel consumption units, proceed as follows. If “mile” is selected, skip step 3.

3. Select the units you want to use.

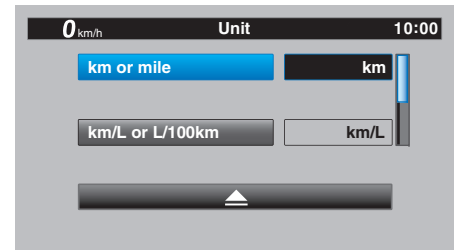

4. Select the triangle symbol to exit.

# Instrument and control functions

## “Wallpaper”

This module allows you to individually set the STREET MODE and TRACK MODE display background colors to black or white for both day and night settings. A photo sensor equipped in the instrument panel detects lighting conditions and will automatically change the display between its day and night settings. The photo sensor also controls a subtle automatic brightness adjustment function within both day and night modes to suit ambient light conditions.

4



1. Photo sensor

### To set the wallpaper

1. From the MENU screen, select “Wallpaper”.

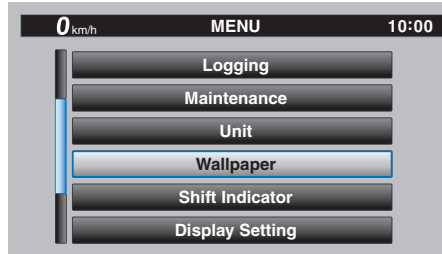

2. Select the mode you want to adjust (select DAY for daytime display settings or NIGHT for nighttime display settings).



3. Select the background color (select “BLACK” for a black background or “WHITE” for a white background).

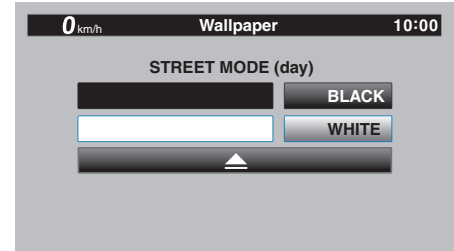

4. Select the triangle symbol to exit.
5. To set another background color, repeat from step 2 or select the triangle symbol to exit this module.

## “Shift indicator”

The shift indicator module contains the following modules.

Module	Description
Shift IND Setting	Set the shift indicator pattern to “ON”, “Flash”, or “OFF” and adjust at what r/min the indicator will come on and go off.
Shift IND Brightness	Adjust the brightness of the shift indicator.
Tach IND Setting	Set the tachometer color display to “ON” or “OFF” and adjust at what r/min the tachometer will be green and orange.



# Instrument and control functions

Peak Rev IND Setting	Set the tachometer peak rev indicator to "ON" or "OFF".
----------------------	---

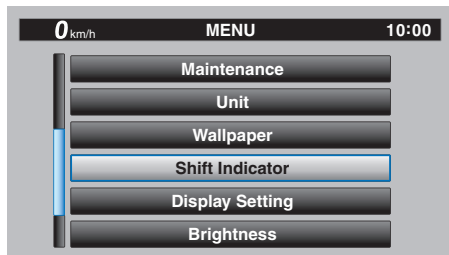

## To make setting changes

1. Select "Shift IND Setting".

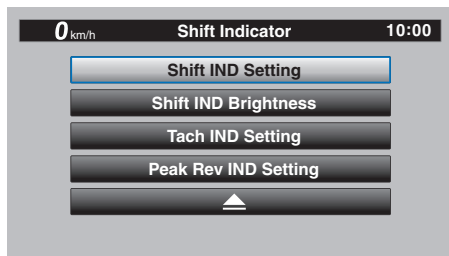

2. Select "IND Mode".

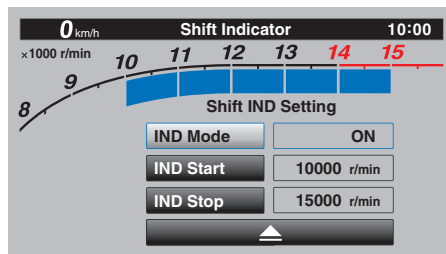

3. Select "ON" to have the indicator light steadily, "OFF" to turn the indicator off, or "Flash" to have the shift indicator flash when the indicator start threshold has been reached.

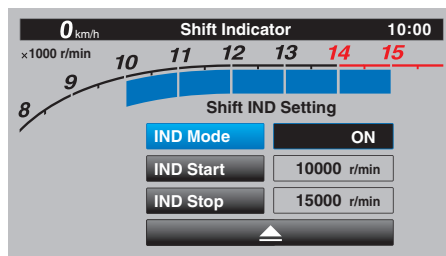

4. Select "IND Start".

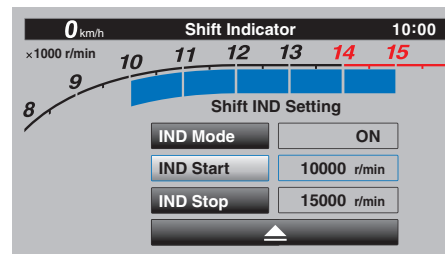

5. Rotate the wheel switch to adjust the r/min at which the shift timing indicator light will come on. "IND Start" operational range is 8000–14800 r/min.

# Instrument and control functions

6. Select “IND Stop”, and then rotate the wheel switch to adjust the r/min at which the shift timing indicator will go off. “IND Stop” operational range is 8500–15000 r/min.

## TIP

The blue area on the tachometer indicates the currently set operational range of the shift indicator light.

4

## “Shift IND Brightness”

The shift timing indicator light has six brightness levels.

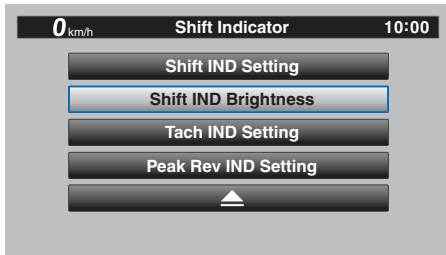

Select “Shift IND Brightness”, then use the wheel switch to adjust the setting. Short push the wheel switch to confirm the setting and exit.

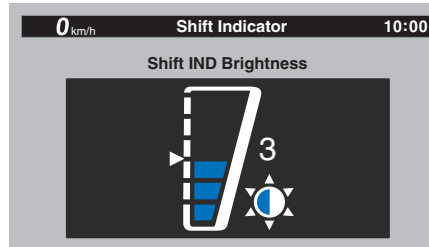

## “Tach IND Setting”

This module allows you to turn the tachometer color display on or off. When turned off, the tachometer will display all r/min levels below the red zone in black or white (depending on wallpaper settings). When turned on, the mid and mid-to-high r/min zones can be set to come on in green and then orange colors.

1. Select “Tach IND Setting”.

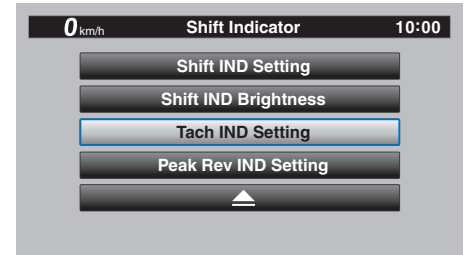

2. Select “IND Mode”.

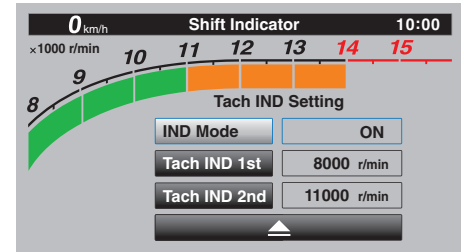

3. Select ON to turn the tachometer color display mode on (or select OFF to turn this function off).

# Instrument and control functions

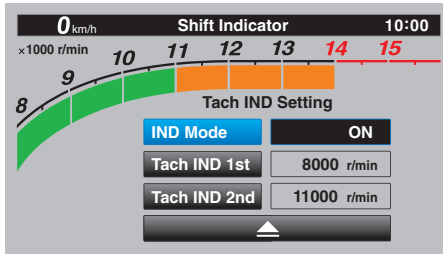

4. Select “Tach IND 1st” to set the green zone starting r/min.

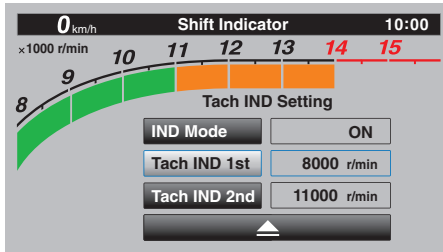

5. Set the starting r/min by rotating and then short pushing the wheel switch. All r/min above this value up to the “Tach IND 2nd” setting value (or the 14000 r/min red zone), will be displayed in green.

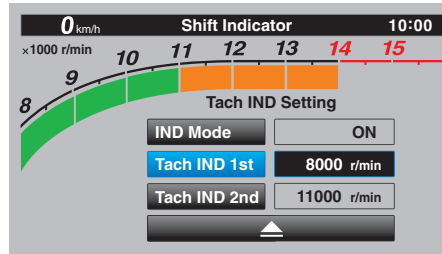

**TIP** \_\_\_\_\_  
Green bar start setting range: 8000–10000 r/min.

6. Select “Tach IND 2nd”.

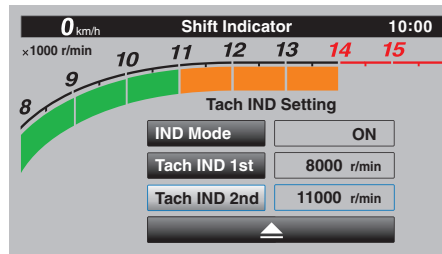

7. Set the orange color starting r/min by rotating and then short pushing the wheel switch. All r/min above this figure until the 14000 r/min red zone, will be displayed in orange.

**TIP** \_\_\_\_\_  
Orange bar start setting range: 8000–14000 r/min.

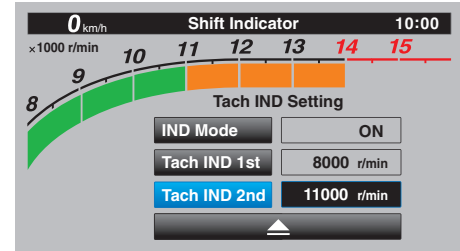

8. Select the triangle symbol to exit.

## “Peak Rev IND Setting”

This module allows you to turn the rev-olution peak hold indicator on or off.

1. Select “Peak Rev IND Setting”.

# Instrument and control functions

4

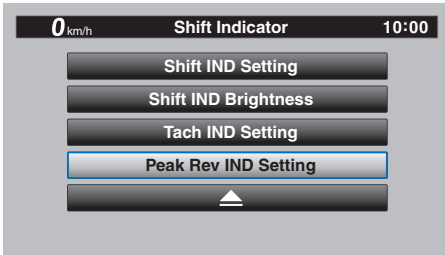

2. Select “IND Mode” and then select ON (to turn on the indicator) or OFF (to turn off the indicator).

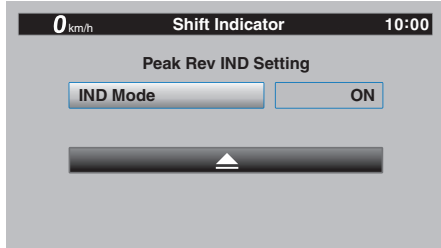

3. Select the triangle symbol to exit.

## “Display Setting”

This module allows you to set how the information display items (like TRIP-1, ODO, C. TEMP, etc.) are grouped on the main screen. There are four display groups.

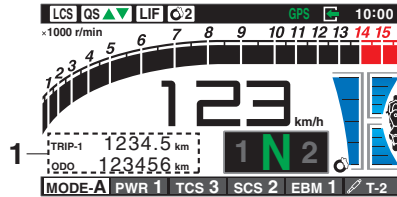

1. Information display item (STREET MODE)

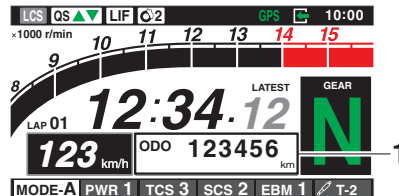

1. Information display item (TRACK MODE)

## To set the display groups

1. From the MENU screen, select “Display Setting”.

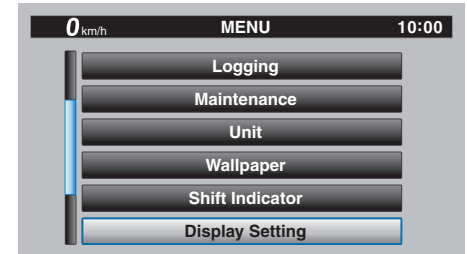

2. “DISPLAY-1”, “DISPLAY-2”, “DISPLAY-3” and “DISPLAY-4” are displayed.

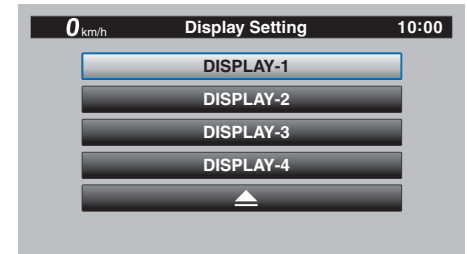

3. For example, let’s select “DISPLAY-1”.
4. Select “STREET MODE 1-1”.

# Instrument and control functions

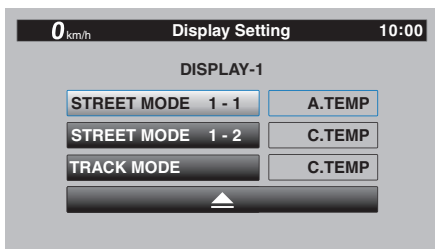

5. Select the desired information display item with the wheel switch.

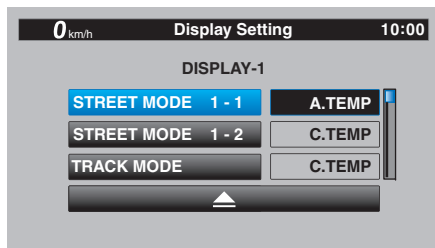

## TIP \_\_\_\_\_

The information display items which can be selected are:

- A.TEMP: air temperature
- C.TEMP: coolant temperature
- TRIP-1: tripmeter 1
- TRIP-2: tripmeter 2

ODO: odometer  
FUEL CON: the amount of fuel consumed  
FUEL AVG: average fuel consumption  
CRNT FUEL: current fuel consumption

6. Select “STREET MODE 1-2” or “TRACK MODE” to set the remaining DISPLAY-1 group items.

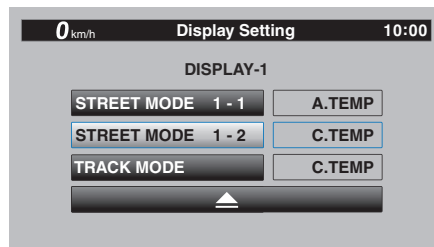

7. Select the triangle symbol to exit. To set the other display groups, repeat from step 3.

## “Brightness”

This module allows you to adjust the general brightness level of the display screen.

## To set the brightness

1. From the MENU screen, select “Brightness”.

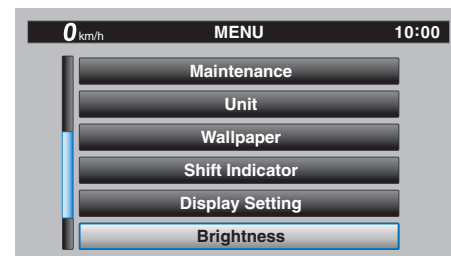

2. Select the desired brightness level by rotating the wheel switch, and then short push the wheel switch to fix the setting.

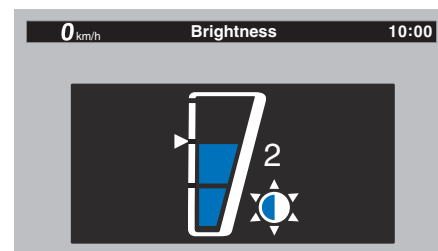

# Instrument and control functions

## “Clock”

This module allows you to set the clock.

### To set the clock

1. From the MENU screen, select “Clock”.

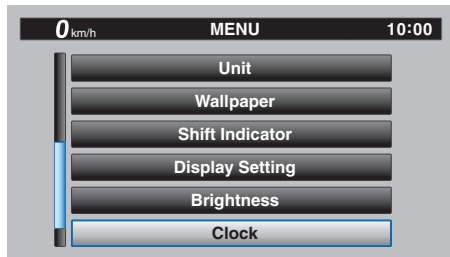

2. When “Clock” is selected, the hours figure will be highlighted.

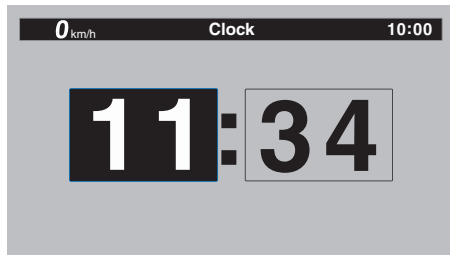

3. Set the hour by rotating and then short push the wheel switch.



4. The minutes figure will become highlighted.

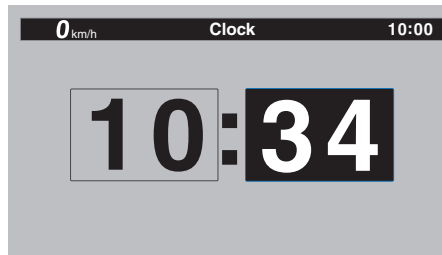

5. Set the minutes figure by rotating and then short push the wheel switch.

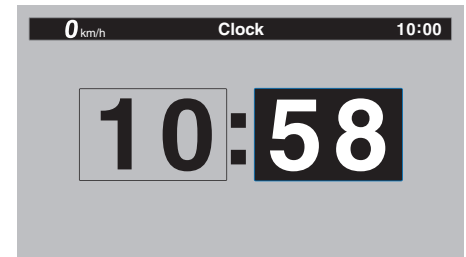

6. Short push the wheel switch again to exit and go back to the MENU screen.

## “All Reset”

This module resets everything, except the odometer and clock, to its factory preset or default setting. Select YES to reset all items. After selecting YES, all items will be reset and the screen will automatically return to the MENU screen.

## Clutch lever

EAU12823

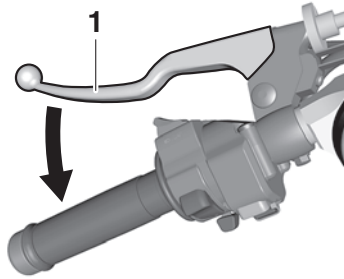

1. Clutch lever

To disengage the drivetrain from the engine, such as when shifting gears, pull the clutch lever toward the handlebar. Release the lever to engage the clutch and transmit power to the rear wheel.

**TIP** \_\_\_\_\_  
The lever should be pulled rapidly and released slowly for smooth shifting. (See page 6-3.)

## Shift pedal

EAU83690

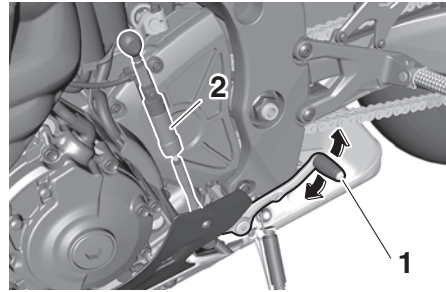

1. Shift pedal  
2. Shift sensor

The shift pedal is located on the left side of the motorcycle. To shift the transmission to a higher gear, move the shift pedal up. To shift to the transmission to a lower gear, move the the shift pedal down. (See page 6-3.)

The shift rod is equipped with a shift sensor, which is part of the quick shift system. The shift sensor reads up and down movement, as well as the strength of the input force when the shift pedal is moved.

**TIP** \_\_\_\_\_  
To prevent unintended shifts, QSS is programmed to ignore unclear input signals. Therefore, be sure to shift using quick and sufficiently forceful inputs.

# Instrument and control functions

## Brake lever

EAU26827

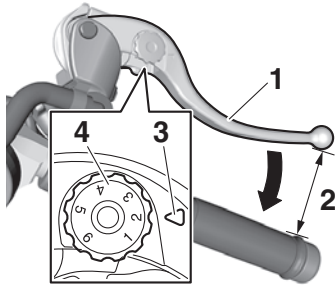

4

1. Brake lever
2. Distance
3. Match mark
4. Adjusting dial

The brake lever is located on the right side of the handlebar. To apply the front brake, pull the lever toward the throttle grip.

The brake lever is equipped with a brake lever position adjusting dial. To adjust the distance between the brake lever and the throttle grip, push the brake lever away from the throttle grip and rotate the adjusting dial. Make sure the setting number on the adjusting dial aligns with the match mark on the brake lever.

## Brake pedal

EAU12944

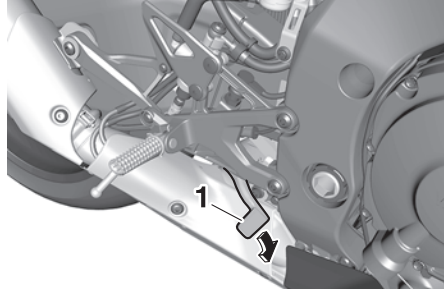

1. Brake pedal

The brake pedal is located on the right side of the motorcycle. To apply the rear brake, press down on the brake pedal.

## Brake control system (BC)

EAU88462

The brake control system regulates hydraulic brake pressure for the front and rear wheels independently when the respective brake lever or brake pedal is applied and wheel lock is detected. There are two settings, BC1 and BC2. BC1 is standard ABS, which adjusts brake pressure based on vehicle speed and wheel speed data. BC1 is designed to engage and maximize braking when the vehicle is upright.

Regarding ABS, operate the brakes as you would conventional brakes. When the brake control system engages, a pulsating sensation may be felt at the brake lever or brake pedal as the hydraulic unit rapidly applies and reduces brake pressure. In this situation, continue to apply the brake lever and brake pedal to allow the ABS to work—do not “pump the brakes” as this will reduce braking effectiveness.

EWA16051

### **WARNING**

**Always keep a sufficient distance from the vehicle ahead to match the riding speed even with ABS.**



- The ABS performs best with long braking distances.
- On certain surfaces, such as rough or gravel roads, the braking distance may be longer with the ABS than without.

BC2 incorporates standard ABS and in addition regulates braking power when cornering to suppress lateral wheel slip.

EWA20891

## WARNING

The brake control system is not a substitute for the use of proper riding and braking techniques. The brake control system cannot prevent all loss of traction due to over-braking from excessive speed, or lateral wheel slip when braking on slippery surfaces.

The ABS hydraulic unit is monitored by the ABS ECU, which will revert the system to conventional braking if a malfunction occurs.

## TIP

The ABS performs a self-diagnosis test when the vehicle is started and reaches a speed of 10 km/h (6 mi/h). During this test, a clicking noise may be audible from the hydraulic control unit, and a vibration may be felt at the brake lever or pedal, but this is normal.

ECA20100

## NOTICE

Be careful not to damage the wheel sensor or wheel sensor rotor; otherwise, improper performance of the ABS will result.

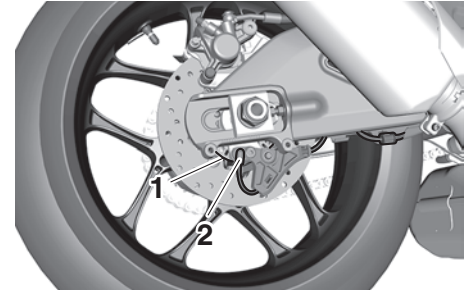

1. Rear wheel sensor rotor
2. Rear wheel sensor

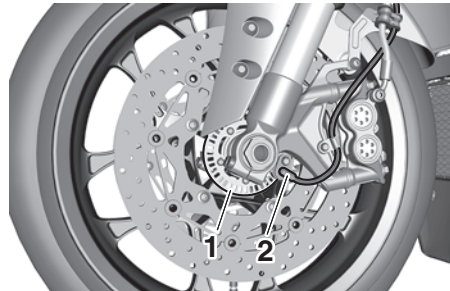

1. Front wheel sensor rotor
2. Front wheel sensor

# Instrument and control functions

## Fuel tank cap

EAU13076

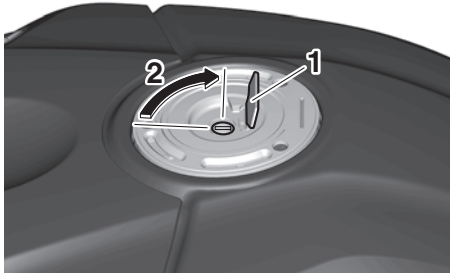

1. Fuel tank cap lock cover
2. Unlock.

### To open the fuel tank cap

Open the fuel tank cap lock cover, insert the key into the lock, and then turn it 1/4 turn clockwise. The lock will be released and the fuel tank cap can be opened.

### To close the fuel tank cap

With the key still inserted in the lock, push down the fuel tank cap. Turn the key 1/4 turn counterclockwise, remove it, and then close the lock cover.

### TIP \_\_\_\_\_

The fuel tank cap cannot be closed unless the key is in the lock. In addition, the key cannot be removed if the cap is not properly closed and locked.

EWA11092

### **WARNING** \_\_\_\_\_

**Make sure that the fuel tank cap is properly closed after filling fuel. Leaking fuel is a fire hazard.**

## Fuel

EAU13222

Make sure there is sufficient gasoline in the tank.

EWA10882

### **WARNING** \_\_\_\_\_

**Gasoline and gasoline vapors are extremely flammable. To avoid fires and explosions and to reduce the risk of injury when refueling, follow these instructions.**

1. Before refueling, turn off the engine and be sure that no one is sitting on the vehicle. Never refuel while smoking, or while in the vicinity of sparks, open flames, or other sources of ignition such as the pilot lights of water heaters and clothes dryers.
2. Do not overfill the fuel tank. When refueling, be sure to insert the pump nozzle into the fuel tank filler hole. Stop filling when the fuel reaches the bottom of the filler tube. Because fuel expands when it heats up, heat from the engine or the sun can cause fuel to spill out of the fuel tank.

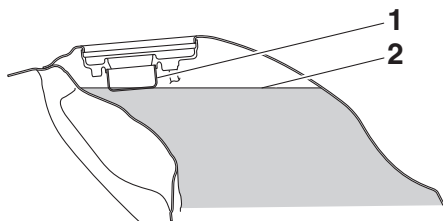

1. Fuel tank filler tube
2. Maximum fuel level

3. Wipe up any spilled fuel immediately. **NOTICE: Immediately wipe off spilled fuel with a clean, dry, soft cloth, since fuel may deteriorate painted surfaces or plastic parts.** [ECA10072]
4. Be sure to securely close the fuel tank cap.

EWA15152

## **WARNING**

Gasoline is poisonous and can cause injury or death. Handle gasoline with care. Never siphon gasoline by mouth. If you should swallow some gasoline or inhale a lot of gasoline vapor, or get some gasoline in your eyes, see your doctor immedi-

ately. If gasoline spills on your skin, wash with soap and water. If gasoline spills on your clothing, change your clothes.

EAU86072

Your Yamaha engine was designed to use unleaded gasoline with a research octane number of 95 or higher. If engine knocking or pinging occurs, use a gasoline of a different brand or higher octane rating.

### Recommended fuel:

Unleaded gasoline (E10 acceptable)

### Octane number (RON):

95

### Fuel tank capacity:

17 L (4.5 US gal, 3.7 Imp.gal)

### Fuel tank reserve:

3.0 L (0.79 US gal, 0.66 Imp.gal)



## TIP

- This mark identifies the recommended fuel for this vehicle as specified by European regulation (EN228).
- Confirm the gasoline pump nozzle has the same fuel identification mark.

## Gasohol

There are two types of gasohol: gasohol containing ethanol and that containing methanol. Gasohol containing ethanol can be used if the ethanol content does not exceed 10% (E10). Gasohol containing methanol is not recommended by Yamaha because it can cause damage to the fuel system or vehicle performance problems.

# Instrument and control functions

## NOTICE

ECA11401

Use only unleaded gasoline. The use of leaded gasoline will cause severe damage to internal engine parts, such as the valves and piston rings, as well as to the exhaust system.

4

## Fuel tank overflow hose

EAU86160

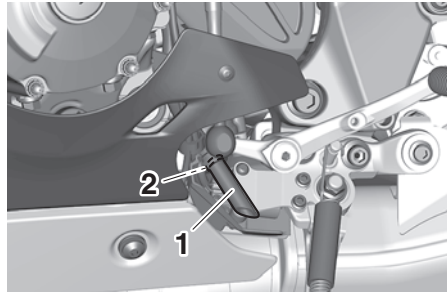

1. Fuel tank overflow hose
2. White mark

The overflow hose drains excess gasoline and directs it safely away from the vehicle.

Before operating the vehicle:

- Check the fuel tank overflow hose connection.
- Check the fuel tank overflow hose for cracks or damage, and replace it if necessary.
- Make sure that the fuel tank overflow hose is not blocked, and clean it if necessary.
- Make sure that the fuel tank overflow hose is positioned as shown.

## TIP

See page 7-13 for canister information.

## Catalytic converter

EAU13435

The exhaust system contains catalytic converter(s) to reduce harmful exhaust emissions.

EWA10863



### WARNING

The exhaust system is hot after operation. To prevent a fire hazard or burns:

- Do not park the vehicle near possible fire hazards such as grass or other materials that easily burn.
- Park the vehicle in a place where pedestrians or children are not likely to touch the hot exhaust system.
- Make sure that the exhaust system has cooled down before doing any maintenance work.
- Do not allow the engine to idle more than a few minutes. Long idling can cause a build-up of heat.

## Seats

EAU79902

### Passenger seat

#### To remove the passenger seat

1. Insert the key into the seat lock, and then turn it clockwise.

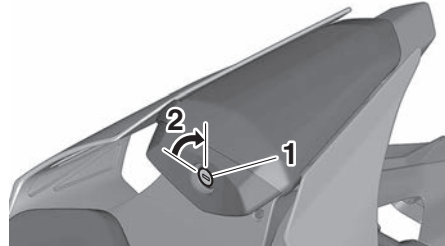

1. Seat lock
2. Unlock.

2. Lift the front of the passenger seat and pull it forward.

#### To install the passenger seat

1. With the seat lock key still in the open position (turned clockwise), insert the projection on the rear of the passenger seat into the seat

holder as shown, and then push the front of the seat down to lock it in place.

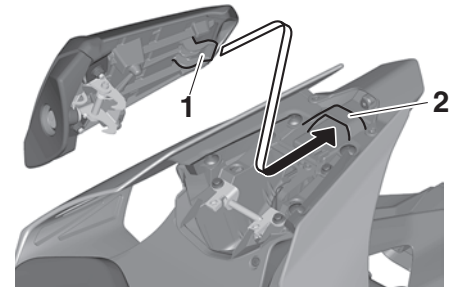

1. Projection
2. Seat holder

2. Remove the key.

### Rider seat

#### To remove the rider seat

1. Remove the passenger seat.
2. Pull up the corners on the rear of the rider seat, remove the bolts with the hexagon wrench (see page 7-2), and then pull the seat off.

# Instrument and control functions

EAU67156

4

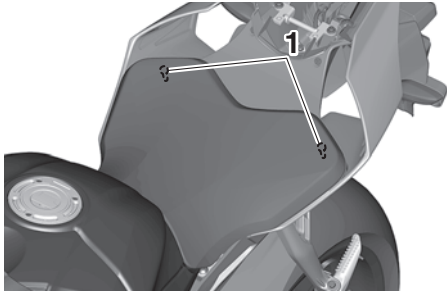

1. Bolt

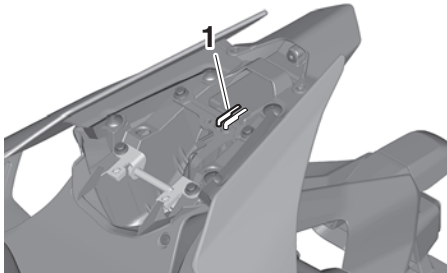

1. Hexagon wrench

## To install the rider seat

1. Insert the projection into the seat holder as shown, then place the seat in the original position.

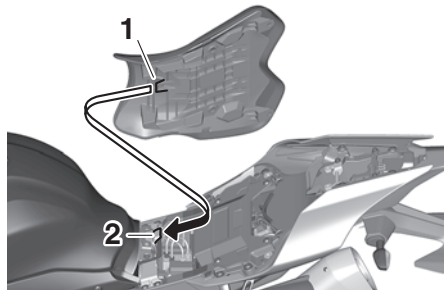

1. Projection  
2. Seat holder

2. Install the bolts with the hexagon wrench.
3. Insert the hexagon wrench back into its holder.
4. Install the passenger seat.

## TIP

Make sure that the seats are properly secured before riding.

## **CCU (for equipped models)**

The CCU (communication control unit) connects to the vehicle's CAN (controller area network) and has a GPS receiver to enable the recording of vehicle and riding data (see "Logging" on page 4-22). Logging data and YRC setting data can be accessed when a smartphone or tablet is connected to the CCU wireless network.

## **TIP**

From the Google© or Apple© application store, download the "Y-TRAC" application to make use of the logging data and the "YRC Setting" application to remotely adjust the YRC settings.

## To connect to the CCU wireless network

1. Remove the screws, move the GPS receiver, and then remove the seat cover as shown.

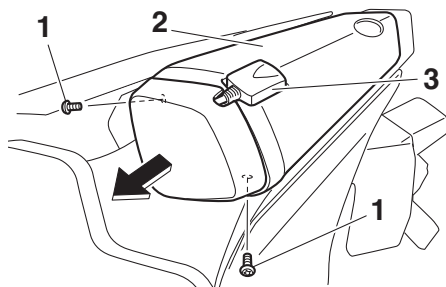

- 1. Screw
- 2. Seat cover
- 3. GPS receiver

2. Note down the CCU serial number.

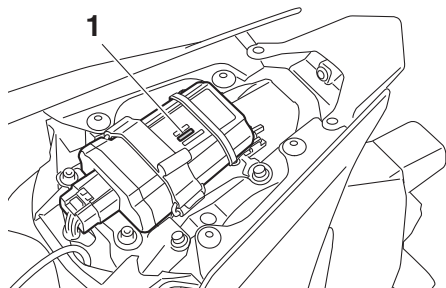

- 1. CCU serial number

3. Turn the key to “ON” and approach the vehicle with a wireless capable smartphone or tablet.

- 4. Connect to the wireless network “YAMAHA MOTOR CCU” by inputting the CCU serial number as the password.
- 5. Install the seat cover and GPS receiver to the original position, and then install the screws.

**TIP** \_\_\_\_\_  
Since all CCU-equipped models put out a similarly named wireless network, have only one vehicle turned on at a time to avoid confusion.

## Seat cover (for equipped models)

When the seat cover is attached, the total number of occupants is reduced to one person. Depending on your area’s regulations, it may be necessary to change the vehicle’s registration to reflect this. Contact your local authorities.

# Instrument and control functions

## Document storage

EAU66920

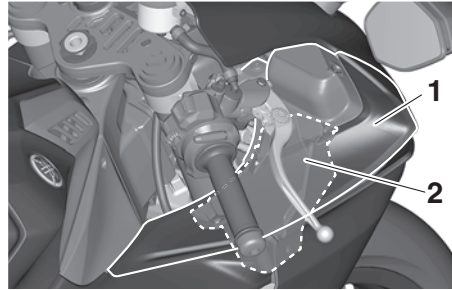

1. Panel B
2. Document storage space

A document storage space is located under panel B. (See page 7-9.) When storing the owner's manual or vehicle registration and insurance documents in the document storage space, be sure to wrap them in a plastic bag so that they will not get wet. When washing the vehicle, avoid letting water enter the document storage space.

### NOTICE

**Do not place heat-sensitive items in the document storage space. This space can get hot when the engine is running or when the vehicle is in direct sunlight.**

ECA22540

## Rear view mirrors

EAU39672

The rear view mirrors of this vehicle can be folded forward or backward for parking in narrow spaces. Fold the mirrors back to their original position before riding.

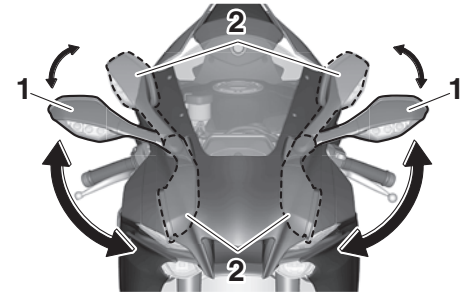

1. Riding position
2. Parking position

### **!** WARNING

EWA14372

**Be sure to fold the rear view mirrors back to their original position before riding.**



## Adjusting the front fork

EAU66477

ECA22472

### NOTICE

- Use extra care to avoid scratching the anodized finish when making suspension adjustments.
- To avoid damaging the suspension's internal mechanisms, do not attempt to turn beyond the maximum or minimum settings.

### For YZF-R1

This model is equipped with adjustable suspension. The spring preload, rebound damping force, and compression damping force of each leg can be adjusted.

EWA10181

### WARNING

Always adjust both fork legs equally, otherwise poor handling and loss of stability may result.

### Spring preload

Turn the adjusting nut in direction (a) to increase the spring preload.

Turn the adjusting nut in direction (b) to decrease the spring preload.

To set the spring preload, turn the adjuster in direction (b) until it stops, and then count the turns in direction (a).

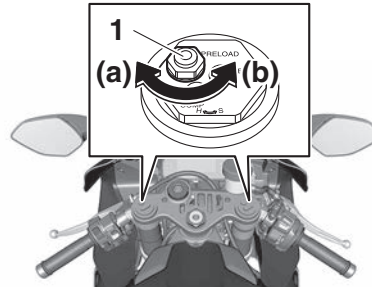

1. Spring preload adjusting nut

#### Spring preload setting:

Minimum (soft):

0 turn(s) in direction (a)

Standard:

6 turn(s) in direction (a)

Maximum (hard):

15 turn(s) in direction (a)

### TIP

When turning the spring preload adjuster in direction (a), it may turn beyond the stated specifications, however such adjustments are ineffective and may damage the suspension.

### Rebound damping force

Turn the adjusting bolt in direction (a) to increase the rebound damping force.

Turn the adjusting bolt in direction (b) to decrease the rebound damping force.

To set the rebound damping force, turn the adjuster in direction (a) until it stops, and then count the clicks in direction (b).

# Instrument and control functions

4

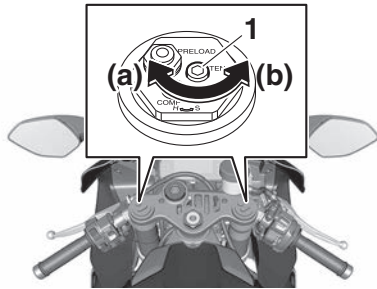

1. Rebound damping force adjusting bolt

## Rebound damping setting:

- Minimum (soft):  
14 click(s) in direction (b)
- Standard:  
7 click(s) in direction (b)
- Maximum (hard):  
1 click(s) in direction (b)

## TIP

- When turning the damping force adjuster in direction (a), the 0 click position and the 1 click position may be the same.
- When turning the damping force adjuster in direction (b), it may click beyond the stated specifications, however such adjustments are ineffective and may damage the suspension.

tions, however such adjustments are ineffective and may damage the suspension.

## Compression damping force

Turn the adjusting bolt in direction (a) to increase the compression damping force.

Turn the adjusting bolt in direction (b) to decrease the compression damping force.

To set the compression damping force, turn the adjuster in direction (a) until it stops, and then count the clicks in direction (b).

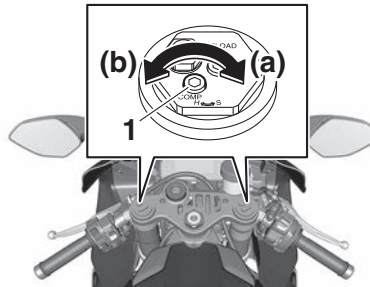

1. Compression damping force adjusting bolt

## Compression damping setting:

- Minimum (soft):  
23 click(s) in direction (b)
- Standard:  
17 click(s) in direction (b)
- Maximum (hard):  
1 click(s) in direction (b)

## TIP

- When turning the damping force adjuster in direction (a), the 0 click position and the 1 click position may be the same.
- When turning the damping force adjuster in direction (b), it may click beyond the stated specifications, however such adjustments are ineffective and may damage the suspension.

## For YZF-R1M

This model is equipped with ÖHLINS electronic racing suspension with gas reservoir. The compression and rebound damping forces are electronically adjusted (see ERS on page 4-19). The spring preload is manually adjusted.

EWA20900

## **WARNING**

The front fork legs contain highly pressurized nitrogen gas. Read and understand the following information before handling the front fork legs.

- Do not subject the axle brackets to open flame or other heat source. This may cause the units to explode due to excessive gas pressure.
- Do not attempt to open the gas cylinder assemblies.
- Do not deform or damage the cylinders in any way. Cylinder damage will result in poor damping performance.
- Do not dispose of a damaged or worn-out front fork leg yourself. Take the front fork leg to a Yamaha dealer for disposal.

## Spring preload

1. Turn the vehicle off.
2. Slide the rubber cover back at each coupler.

3. Remove the coupler on each front fork. **NOTICE:** To prevent damaging the couplers, do not use sharp tools or excessive force.

[ECA22770]

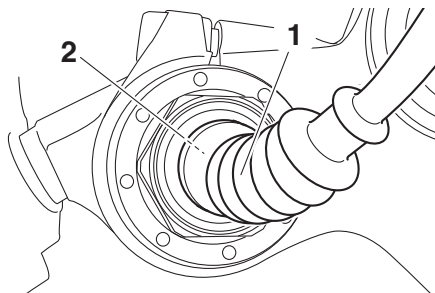

1. Rubber cover
2. Coupler

4. Turn the adjusting bolt in direction (a) to increase the spring preload. Turn the adjusting bolt in direction (b) to decrease the spring preload. To set the spring preload, turn the adjuster in direction (b) until it stops, and then count the turns in direction (a).

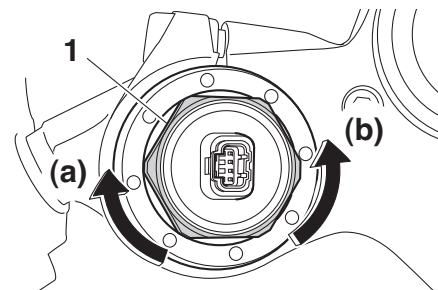

1. Spring preload adjusting bolt

## Spring preload setting:

Minimum (soft):

0 turn(s) in direction (a)

Standard:

3 turn(s) in direction (a)

Maximum (hard):

15 turn(s) in direction (a)

## TIP

When turning the spring preload adjuster in direction (a), it may turn beyond the stated specifications, however such adjustments are ineffective and may damage the suspension.

5. Attach the coupler on each fork.
6. Slide the rubber cover to the original position.

# Instrument and control functions

## Adjusting the shock absorber assembly

EAU66497

EWA10222

### **⚠ WARNING**

This shock absorber assembly contains highly pressurized nitrogen gas. Read and understand the following information before handling the shock absorber assembly.

- Do not tamper with or attempt to open the cylinder assembly.
- Do not subject the shock absorber assembly to an open flame or other high heat source. This may cause the unit to explode due to excessive gas pressure.
- Do not deform or damage the cylinder in any way. Cylinder damage will result in poor damping performance.
- Do not dispose of a damaged or worn-out shock absorber assembly yourself. Take the shock absorber assembly to a Yamaha dealer for any service.

## For YZF-R1

This model is equipped with adjustable suspension. The spring preload, rebound damping force, fast compression damping force, and slow compression damping force can be adjusted.

ECA10102

### **NOTICE**

To avoid damaging the mechanism, do not attempt to turn beyond the maximum or minimum settings.

## Spring preload

1. Loosen the locknut.
2. Turn the adjusting nut in direction (a) to increase the spring preload. Turn the adjusting nut in direction (b) to decrease the spring preload. The spring preload setting is determined by measuring distance A. The longer distance A is, the higher the spring preload; the shorter distance A is, the lower the spring preload.
  - Use the special wrench included in the tool kit to make the adjustment.

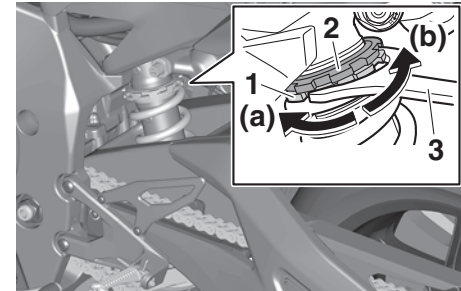

1. Spring preload adjusting nut
2. Locknut
3. Special wrench

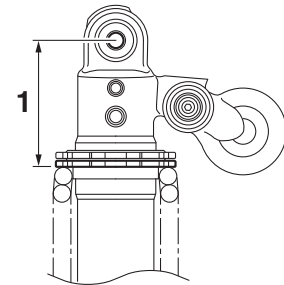

1. Distance A

## Spring preload:

Minimum (soft):

Distance A = 77.5 mm (3.05 in)

Standard:

Distance A = 78.5 mm (3.09 in)

Maximum (hard):

Distance A = 85.5 mm (3.37 in)

3. Tighten the locknut to the specified torque. **NOTICE: Always tighten the locknut against the adjusting ring, and then tighten the locknut to the specified torque.** [ECA22760]

## Tightening torque:

Locknut:

28 N·m (2.8 kgf·m, 21 lb·ft)

## Rebound damping force

Turn the adjusting bolt in direction (a) to increase the rebound damping force.

Turn the adjusting bolt in direction (b) to decrease the rebound damping force.

To set the rebound damping force, turn the adjuster in direction (a) until it stops, and then count the clicks in direction (b).

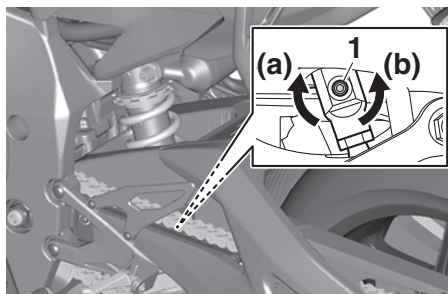

1. Rebound damping force adjusting bolt

## Rebound damping setting:

Minimum (soft):

23 click(s) in direction (b)

Standard:

12 click(s) in direction (b)

Maximum (hard):

1 click(s) in direction (b)

## TIP

- When turning the damping force adjuster in direction (a), the 0 click position and the 1 click position may be the same.
- When turning the damping force adjuster in direction (b), it may click beyond the stated specifica-

tions, however such adjustments are ineffective and may damage the suspension.

## Compression damping force

### Fast compression damping force

Turn the adjusting bolt in direction (a) to increase the compression damping force.

Turn the adjusting bolt in direction (b) to decrease the compression damping force.

To set the compression damping force, turn the adjuster in direction (a) until it stops, and then count the turns in direction (b).

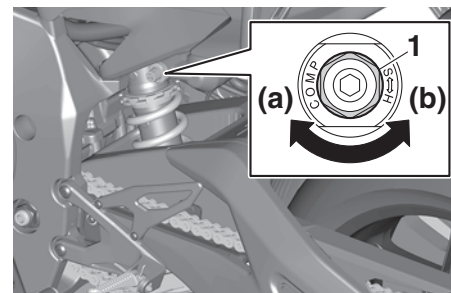

1. Fast compression damping force adjusting bolt

# Instrument and control functions

## Fast compression damping setting

- Minimum (soft):  
5.5 turn(s) in direction (b)
- Standard:  
3 turn(s) in direction (b)
- Maximum (hard):  
0 turn(s) in direction (b)

4

## TIP

When turning the damping force adjuster in direction (b), it may turn beyond the stated specifications, however such adjustments are ineffective and may damage the suspension.

## Slow compression damping force

Turn the adjusting bolt in direction (a) to increase the compression damping force.

Turn the adjusting bolt in direction (b) to decrease the compression damping force.

To set the compression damping force, turn the adjuster in direction (a) until it stops, and then count the clicks in direction (b).

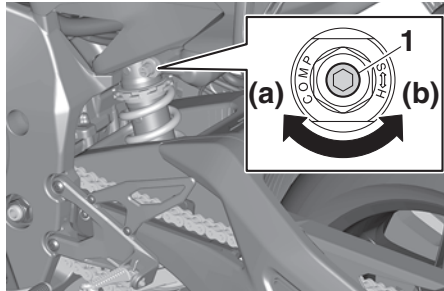

1. Slow compression damping force adjusting bolt

## Slow compression damping setting

- Minimum (soft):  
18 click(s) in direction (b)
- Standard:  
12 click(s) in direction (b)
- Maximum (hard):  
1 click(s) in direction (b)

## TIP

- When turning the damping force adjuster in direction (a), the 0 click position and the 1 click position may be the same.
- When turning the damping force adjuster in direction (b), it may click beyond the stated specifications, however such adjustments are ineffective and may damage the suspension.

tions, however such adjustments are ineffective and may damage the suspension.

## For YZF-R1M

This model is equipped with ÖHLINS electronic racing suspension.

## Compression damping force and rebound damping force

The compression and rebound damping forces are electronically controlled and can be adjusted from the MENU screen. See ERS on page 4-19 for information on how to adjust these settings.

## Spring preload

The spring preload adjustment is performed manually.

1. Loosen the locknut.
2. Turn the adjusting nut in direction (a) to increase the spring preload. Turn the adjusting nut in direction (b) to decrease the spring preload. The spring preload setting is determined by measuring distance A. The longer distance A is, the

higher the spring preload; the shorter distance A is, the lower the spring preload.

- Use the special wrench in the tool kit to make the adjustment.

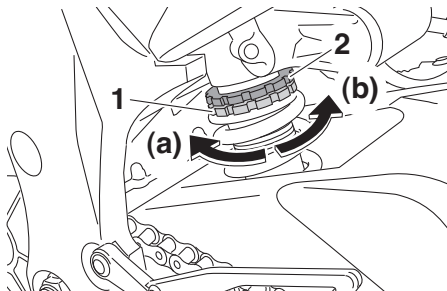

1. Spring preload adjusting nut
2. Locknut

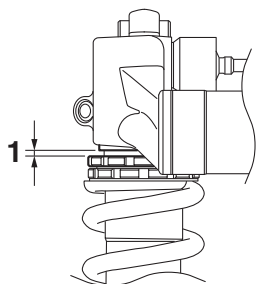

1. Distance A

## Spring preload:

- Minimum (soft):  
Distance A = 0.0 mm (0.00 in)
- Standard:  
Distance A = 4.0 mm (0.16 in)
- Maximum (hard):  
Distance A = 9.0 mm (0.35 in)

3. Tighten the locknut to the specified torque. **NOTICE:** Always tighten the locknut against the adjusting ring, and then tighten the locknut to the specified torque. [ECA22760]

## Tightening torque:

- Locknut:  
25 N·m (2.5 kgf·m, 18 lb·ft)

ECA10102

## NOTICE

To avoid damaging the mechanism, do not attempt to turn beyond the maximum or minimum settings.

## EXUP system

This model is equipped with Yamaha's EXUP (EXhaust Ultimate Power valve) system. This system boosts engine power by means of a valve that controls exhaust flow within the exhaust chamber.

ECA15611

## NOTICE

The EXUP system has been set and extensively tested at the Yamaha factory. Changing these settings without sufficient technical knowledge may result in poor performance of or damage to the engine.

# Instrument and control functions

---

## Auxiliary DC connector

EAU70641

This vehicle is equipped with an auxiliary DC connector. Consult your Yamaha dealer before installing any accessories.

## Sidestand

EAU15306

The sidestand is located on the left side of the frame. Raise the sidestand or lower it with your foot while holding the vehicle upright.

### TIP

The built-in sidestand switch is part of the ignition circuit cut-off system, which cuts the ignition in certain situations. (See the following section for an explanation of the ignition circuit cut-off system.)

EWA10242

### **WARNING**

**The vehicle must not be ridden with the sidestand down, or if the sidestand cannot be properly moved up (or does not stay up), otherwise the sidestand could contact the ground and distract the operator, resulting in a possible loss of control. Yamaha's ignition circuit cut-off system has been designed to assist the operator in fulfilling the responsibility of raising the sidestand before starting off. Therefore, check**

**this system regularly and have a Yamaha dealer repair it if it does not function properly.**

---



EAU57952

## Ignition circuit cut-off system

This system prevents in-gear engine starts unless the clutch lever is pulled and the sidestand is up. Also, it will stop the running engine should the sidestand be lowered while the transmission is in gear.

Periodically check this system via the following procedure.

### TIP

- This check is most reliable if performed with a warmed-up engine.
- See pages 4-2 and 4-3 for switch operation information.

# Instrument and control functions

4

With the engine turned off:  
1. Move the sidestand down.  
2. Set engine stop switch to run position.  
3. Turn main switch to on position.  
4. Shift transmission into neutral.  
5. Push the start switch.  
**Does the engine start?**

YES NO

With the engine still running:  
6. Move the sidestand up.  
7. Pull the clutch lever.  
8. Shift transmission into gear.  
9. Move the sidestand down.  
**Does the engine stall?**

YES NO

After the engine has stalled:  
10. Move the sidestand up.  
11. Pull the clutch lever.  
12. Push the start switch.  
**Does the engine start?**

YES NO

The system is OK. **The motorcycle can be ridden.**

 **WARNING**

**If a malfunction is found, have the vehicle inspected before riding.**

The neutral switch may not be working.  
**The motorcycle should not be ridden** until checked by a Yamaha dealer.

The sidestand switch may not be working.  
**The motorcycle should not be ridden** until checked by a Yamaha dealer.

The clutch switch may not be working.  
**The motorcycle should not be ridden** until checked by a Yamaha dealer.

# For your safety – pre-operation checks

EAU15599

Inspect your vehicle each time you use it to make sure the vehicle is in safe operating condition. Always follow the inspection and maintenance procedures and schedules described in the Owner's Manual.

EWA11152

## **WARNING**

**Failure to inspect or maintain the vehicle properly increases the possibility of an accident or equipment damage. Do not operate the vehicle if you find any problem. If a problem cannot be corrected by the procedures provided in this manual, have the vehicle inspected by a Yamaha dealer.**

Before using this vehicle, check the following points:

ITEM	CHECKS	PAGE
Fuel	<ul style="list-style-type: none"><li>• Check fuel level in fuel tank.</li><li>• Refuel if necessary.</li><li>• Check fuel line for leakage.</li><li>• Check fuel tank overflow hose for obstructions, cracks or damage, and check hose connection.</li></ul>	4-35, 4-37
Engine oil	<ul style="list-style-type: none"><li>• Check oil level in engine.</li><li>• If necessary, add recommended oil to specified level.</li><li>• Check vehicle for oil leakage.</li></ul>	7-14
Coolant	<ul style="list-style-type: none"><li>• Check coolant level in reservoir.</li><li>• If necessary, add recommended coolant to specified level.</li><li>• Check cooling system for leakage.</li></ul>	7-17
Front brake	<ul style="list-style-type: none"><li>• Check operation.</li><li>• If soft or spongy, have Yamaha dealer bleed hydraulic system.</li><li>• Check brake pads for wear.</li><li>• Replace if necessary.</li><li>• Check fluid level in reservoir.</li><li>• If necessary, add specified brake fluid to specified level.</li><li>• Check hydraulic system for leakage.</li></ul>	7-25, 7-25

# For your safety – pre-operation checks

ITEM	CHECKS	PAGE
<b>Rear brake</b>	<ul style="list-style-type: none"> <li>• Check operation.</li> <li>• If soft or spongy, have Yamaha dealer bleed hydraulic system.</li> <li>• Check brake pads for wear.</li> <li>• Replace if necessary.</li> <li>• Check fluid level in reservoir.</li> <li>• If necessary, add specified brake fluid to specified level.</li> <li>• Check hydraulic system for leakage.</li> </ul>	7-25, 7-25
<b>Clutch</b>	<ul style="list-style-type: none"> <li>• Check operation.</li> <li>• Lubricate cable if necessary.</li> <li>• Check lever free play.</li> <li>• Adjust if necessary.</li> </ul>	7-23
<b>Throttle grip</b>	<ul style="list-style-type: none"> <li>• Check for smooth rotation and automatic return.</li> </ul>	7-29
<b>Control cables</b>	<ul style="list-style-type: none"> <li>• Make sure that operation is smooth.</li> <li>• Lubricate if necessary.</li> </ul>	7-29
<b>Drive chain</b>	<ul style="list-style-type: none"> <li>• Check chain slack.</li> <li>• Adjust if necessary.</li> <li>• Check chain condition.</li> <li>• Lubricate if necessary.</li> </ul>	7-27, 7-28
<b>Wheels and tires</b>	<ul style="list-style-type: none"> <li>• Check for damage.</li> <li>• Check tire condition and tread depth.</li> <li>• Check air pressure.</li> <li>• Correct if necessary.</li> </ul>	7-19, 7-22
<b>Brake and shift pedals</b>	<ul style="list-style-type: none"> <li>• Make sure that operation is smooth.</li> <li>• Lubricate pedal pivoting points if necessary.</li> </ul>	7-30
<b>Brake and clutch levers</b>	<ul style="list-style-type: none"> <li>• Make sure that operation is smooth.</li> <li>• Lubricate lever pivoting points if necessary.</li> </ul>	7-30
<b>Sidestand</b>	<ul style="list-style-type: none"> <li>• Make sure that operation is smooth.</li> <li>• Lubricate pivot if necessary.</li> </ul>	7-31
<b>Chassis fasteners</b>	<ul style="list-style-type: none"> <li>• Make sure that all nuts, bolts and screws are properly tightened.</li> <li>• Tighten if necessary.</li> </ul>	—

## For your safety – pre-operation checks

ITEM	CHECKS	PAGE
<b>Air intake duct</b>	<ul style="list-style-type: none"><li>• Make sure that the air intake duct is not blocked.</li><li>• Remove any foreign objects from the screen if necessary.</li></ul>	—
<b>Instruments, lights, signals and switches</b>	<ul style="list-style-type: none"><li>• Check operation.</li><li>• Correct if necessary.</li></ul>	—
<b>Sidestand switch</b>	<ul style="list-style-type: none"><li>• Check operation of ignition circuit cut-off system.</li><li>• If system is not working correctly, have Yamaha dealer check vehicle.</li></ul>	4-49

# Operation and important riding points

---

EAU15952

Read the Owner's Manual carefully to become familiar with all controls. If there is a control or function you do not understand, ask your Yamaha dealer.

EWA10272

## **WARNING**

**Failure to familiarize yourself with the controls can lead to loss of control, which could cause an accident or injury.**

---

6

## Engine break-in

There is never a more important period in the life of your engine than the period between 0 and 1600 km (1000 mi). For this reason, you should read the following material carefully.

Since the engine is brand new, do not put an excessive load on it for the first 1600 km (1000 mi). The various parts in the engine wear and polish themselves to the correct operating clearances. During this period, prolonged full-throttle operation or any condition that might result in engine overheating must be avoided.

EAU16842

## 1600 km (1000 mi) and beyond

The vehicle can now be operated normally.

ECA10311

## **NOTICE**

- **Keep the engine speed out of the tachometer red zone.**
  - **If any engine trouble should occur during the engine break-in period, immediately have a Yamaha dealer check the vehicle.**
- 

## **TIP**

During and after the engine break-in period, the exhaust heat may cause discoloration of the exhaust pipe, but this is normal.

---

EAU17085

## 0–1000 km (0–600 mi)

Avoid prolonged operation above 7000 r/min. **NOTICE: After 1000 km (600 mi) of operation, the engine oil must be changed and the oil filter cartridge or element replaced.** [ECA10303]

## 1000–1600 km (600–1000 mi)

Avoid prolonged operation above 8400 r/min.

## Starting the engine

EAU88420

The ignition circuit cut-off system will enable starting when:

- the transmission is in the neutral position or
- the transmission is in gear, the sidestand is up, and the clutch lever is pulled.

### To start the engine

1. Turn the main switch on and set the engine stop switch to the run position.
2. Confirm the indicator and warning light(s) come on for a few seconds, and then go off. (See page 4-5.)

### TIP

- Do not start the engine if the malfunction indicator light remains on.
- The oil pressure and coolant temperature warning light should come on and stay on until the engine is started.

- The ABS warning light should come on and stay on until the vehicle reaches a speed of 10 km/h (6 mi/h).

ECA24110

### **NOTICE**

**If a warning or indicator light does not work as described above, have a Yamaha dealer check the vehicle.**

3. Shift the transmission into the neutral position.
4. Start the engine by pushing the start switch.
5. Release the start switch when the engine starts, or after 5 seconds. Wait 10 seconds before pressing the switch again to allow battery voltage to restore.

ECA11043

### **NOTICE**

**For maximum engine life, never accelerate hard when the engine is cold!**

EAU68221

### **TIP**

This model is equipped with:

- an inertial measurement unit (IMU). This unit stops the engine in case of a turnover. Turn the main switch off and then on before attempting to restart the engine. Failing to do so will prevent the engine from starting even though the engine will crank when pushing the start switch.
- an engine auto-stop system. The engine stops automatically if left idling for 20 minutes. If the engine stops, simply push the start switch to restart the engine.

# Operation and important riding points

## Shifting

EAU67082

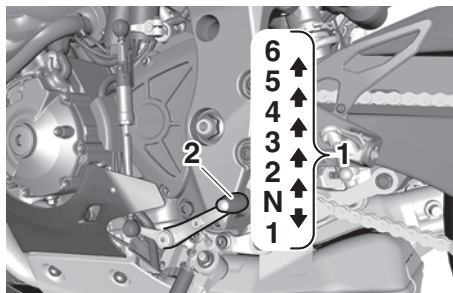

1. Gear positions
2. Shift pedal

6

Shifting gears lets you control the amount of engine power available for starting off, accelerating, climbing hills, etc.

This model is equipped with QSS. See pages 3-3 and 4-17.

### TIP

To shift into neutral (**N**), gently depress the shift pedal from 2nd gear, or slightly raise it while in 1st gear.

### NOTICE

ECA22521

- **Even with the transmission in the neutral position, do not coast for long periods of time with the engine off, nor tow the motorcycle for long distances. The transmission is properly lubricated only when the engine is running. Inadequate lubrication may damage the transmission.**
- **Except when using the quick shift system, always pull the clutch lever when changing gears to avoid damaging the engine, transmission, and drivetrain.**

EAU85370

### To start out and accelerate

1. Pull the clutch lever to disengage the clutch.
2. Shift the transmission into first gear. The neutral indicator light should go out.
3. Open the throttle gradually, and at the same time, release the clutch lever slowly.

4. After starting out, close the throttle, and at the same time, quickly pull the clutch lever in.
5. Shift the transmission into second gear. (Make sure not to shift the transmission into the neutral position.)
6. Open the throttle part way and gradually release the clutch lever.
7. Follow the same procedure when shifting to the next higher gear.

EAU85380

### To decelerate

1. Release the throttle and apply both the front and the rear brakes smoothly to slow the motorcycle.
2. As the vehicle decelerates, shift to a lower gear.
3. When the engine is about to stall or runs roughly, pull the clutch lever in, use the brakes to slow the motorcycle, and continue to downshift as necessary.
4. Once the motorcycle has stopped, the transmission can be shifted into the neutral position.



The neutral indicator light should come on and then the clutch lever can be released.

EWA17380

## **WARNING**

- **Improper braking can cause loss of control or traction. Always use both brakes and apply them smoothly.**
- **Make sure that the motorcycle and the engine have sufficiently slowed before shifting to a lower gear. Engaging a lower gear when the vehicle or engine speed is too high could make the rear wheel lose traction or the engine to over-rev. This could cause loss of control, an accident and injury. It could also cause engine or drive train damage.**

## **Tips for reducing fuel consumption**

EAU16811

Fuel consumption depends largely on your riding style. Consider the following tips to reduce fuel consumption:

- Shift up swiftly, and avoid high engine speeds during acceleration.
- Do not rev the engine while shifting down, and avoid high engine speeds with no load on the engine.
- Turn the engine off instead of letting it idle for an extended length of time (e.g., in traffic jams, at traffic lights or at railroad crossings).

## **Parking**

When parking, stop the engine, and then remove the key from the main switch.

EAU17214

## **WARNING**

EWA10312

- **Since the engine and exhaust system can become very hot, park in a place where pedestrians or children are not likely to touch them and be burned.**
- **Do not park on a slope or on soft ground, otherwise the vehicle may overturn, increasing the risk of a fuel leak and fire.**
- **Do not park near grass or other flammable materials which might catch fire.**

# Periodic maintenance and adjustment

---

EAU17246

EWA15123

EAU17303

Periodic inspection, adjustment, and lubrication will keep your vehicle in the safest and most efficient condition possible. Safety is an obligation of the vehicle owner/operator. The most important points of vehicle inspection, adjustment, and lubrication are explained on the following pages.

The intervals given in the periodic maintenance charts should be simply considered as a general guide under normal riding conditions. However, depending on the weather, terrain, geographical location, and individual use, the maintenance intervals may need to be shortened.

## **WARNING**

EWA10322

**Failure to properly maintain the vehicle or performing maintenance activities incorrectly may increase your risk of injury or death during service or while using the vehicle. If you are not familiar with vehicle service, have a Yamaha dealer perform service.**

---

## **WARNING**

**Turn off the engine when performing maintenance unless otherwise specified.**

- **A running engine has moving parts that can catch on body parts or clothing and electrical parts that can cause shocks or fires.**
  - **Running the engine while servicing can lead to eye injury, burns, fire, or carbon monoxide poisoning – possibly leading to death. See page 1-3 for more information about carbon monoxide.**
- 

## **WARNING**

EWA15461

**Brake discs, calipers, drums, and linings can become very hot during use. To avoid possible burns, let brake components cool before touching them.**

---

Emission controls not only function to ensure cleaner air, but are also vital to proper engine operation and maximum performance. In the following periodic maintenance charts, the services related to emissions control are grouped separately. These services require specialized data, knowledge, and equipment. Maintenance, replacement, or repair of the emission control devices and systems may be performed by any repair establishment or individual that is certified (if applicable). Yamaha dealers are trained and equipped to perform these particular services.

EAU67092

## Tool kit

The tool kit should be stored separately from the vehicle. However, there are some tools located under the seat. (See page 4-38.)

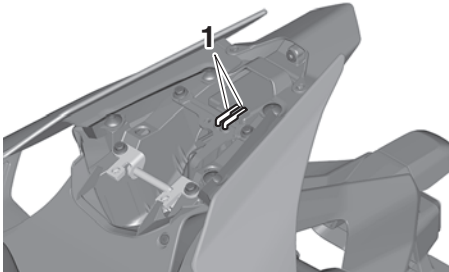

1. Hexagon wrench

The information included in this manual and the tools provided are intended to assist you in the performance of preventive maintenance and minor repairs. However, a torque wrench and other tools are necessary to perform certain maintenance work correctly.

### **TIP** \_\_\_\_\_

If you do not have the tools or experience required for a particular job, have your Yamaha dealer perform it for you.

# Periodic maintenance and adjustment

EAU71033

## Periodic maintenance charts

### TIP

- Items marked with an asterisk should be performed by your Yamaha dealer because these items require special tools, data, and technical skills.
- From 50000 km (30000 mi), repeat the maintenance intervals starting from 10000 km (6000 mi).
- **The annual checks must be performed every year, except if a distance-based maintenance is performed instead.**

EAU71051

## Periodic maintenance chart for the emission control system

NO.	ITEM	CHECK OR MAINTENANCE JOB	ODOMETER READING					ANNUAL CHECK
			1000 km (600 mi)	10000 km (6000 mi)	20000 km (12000 mi)	30000 km (18000 mi)	40000 km (24000 mi)	
1	* Fuel line	<ul style="list-style-type: none"> <li>• Check fuel hoses for cracks or damage.</li> <li>• Replace if necessary.</li> </ul>		√	√	√	√	√
2	* Spark plugs	<ul style="list-style-type: none"> <li>• Check condition.</li> <li>• Adjust gap and clean.</li> </ul>		√		√		
		<ul style="list-style-type: none"> <li>• Replace.</li> </ul>			√		√	
3	* Valve clearance	<ul style="list-style-type: none"> <li>• Check and adjust.</li> </ul>	Every 40000 km (24000 mi)					
4	* Fuel injection	<ul style="list-style-type: none"> <li>• Check engine idle speed.</li> </ul>	√	√	√	√	√	√
		<ul style="list-style-type: none"> <li>• Check and adjust synchronization.</li> </ul>		√	√	√	√	√
5	* Exhaust system	<ul style="list-style-type: none"> <li>• Check for leakage.</li> <li>• Tighten if necessary.</li> <li>• Replace gaskets if necessary.</li> </ul>	√	√	√	√	√	

# Periodic maintenance and adjustment

NO.	ITEM	CHECK OR MAINTENANCE JOB	ODOMETER READING					ANNUAL CHECK
			1000 km (600 mi)	10000 km (6000 mi)	20000 km (12000 mi)	30000 km (18000 mi)	40000 km (24000 mi)	
6	* <b>Evaporative emission control system</b>	<ul style="list-style-type: none"> <li>• Check control system for damage.</li> <li>• Replace if necessary.</li> </ul>			√		√	
7	* <b>Air induction system</b>	<ul style="list-style-type: none"> <li>• Check the air cut-off valve, reed valve, and hose for damage.</li> <li>• Replace any damaged parts if necessary.</li> </ul>		√	√	√	√	√

# Periodic maintenance and adjustment

EAU71352

## General maintenance and lubrication chart

NO.	ITEM	CHECK OR MAINTENANCE JOB	ODOMETER READING					ANNUAL CHECK
			1000 km (600 mi)	10000 km (6000 mi)	20000 km (12000 mi)	30000 km (18000 mi)	40000 km (24000 mi)	
1	* Diagnostic system check	<ul style="list-style-type: none"> <li>Perform dynamic inspection using Yamaha diagnostic tool.</li> <li>Check the error codes.</li> </ul>	√	√	√	√	√	√
2	* Air filter element	<ul style="list-style-type: none"> <li>Replace.</li> </ul>	Every 40000 km (24000 mi)					
3	Clutch	<ul style="list-style-type: none"> <li>Check operation.</li> <li>Adjust.</li> </ul>	√	√	√	√	√	
4	* Front brake	<ul style="list-style-type: none"> <li>Check operation, fluid level, and for fluid leakage.</li> <li>Replace brake pads if necessary.</li> </ul>	√	√	√	√	√	√
5	* Rear brake	<ul style="list-style-type: none"> <li>Check operation, fluid level, and for fluid leakage.</li> <li>Replace brake pads if necessary.</li> </ul>	√	√	√	√	√	√
6	* Brake hoses	<ul style="list-style-type: none"> <li>Check for cracks or damage.</li> <li>Replace.</li> </ul>		√	√	√	√	√
7	* Brake fluid	<ul style="list-style-type: none"> <li>Change.</li> </ul>	Every 2 years					
8	* Wheels	<ul style="list-style-type: none"> <li>Check runout and for damage.</li> <li>Replace if necessary.</li> </ul>		√	√	√	√	
9	* Tires	<ul style="list-style-type: none"> <li>Check tread depth and for damage.</li> <li>Replace if necessary.</li> <li>Check air pressure.</li> <li>Correct if necessary.</li> </ul>		√	√	√	√	√
10	* Wheel bearings	<ul style="list-style-type: none"> <li>Check bearing for looseness or damage.</li> </ul>		√	√	√	√	

7

# Periodic maintenance and adjustment

NO.	ITEM	CHECK OR MAINTENANCE JOB	ODOMETER READING					ANNUAL CHECK
			1000 km (600 mi)	10000 km (6000 mi)	20000 km (12000 mi)	30000 km (18000 mi)	40000 km (24000 mi)	
11	* Swingarm pivot bearings	• Check operation and for excessive play.		√	√	√	√	
		• Lubricate with lithium-soap-based grease.	Every 50000 km (30000 mi)					
12	Drive chain	<ul style="list-style-type: none"> <li>• Check chain slack, alignment and condition.</li> <li>• Adjust and lubricate chain with a special O-ring chain lubricant thoroughly.</li> </ul>	Every 800 km (500 mi) and after washing the motorcycle, riding in the rain or riding in wet areas					
13	* Steering bearings	• Check bearing assemblies for looseness.	√	√		√		
		• Moderately repack with lithium-soap-based grease.			√		√	
14	* Steering damper	• Check operation and for oil leakage.		√	√	√	√	
15	* Chassis fasteners	• Make sure that all nuts, bolts and screws are properly tightened.		√	√	√	√	√
16	Brake lever pivot shaft	• Lubricate with silicone grease.		√	√	√	√	√
17	Brake pedal pivot shaft	• Lubricate with lithium-soap-based grease.		√	√	√	√	√
18	Clutch lever pivot shaft	• Lubricate with lithium-soap-based grease.		√	√	√	√	√
19	Shift pedal pivot shaft	• Lubricate with molybdenum disulfide grease.		√	√	√	√	√

# Periodic maintenance and adjustment

NO.	ITEM	CHECK OR MAINTENANCE JOB	ODOMETER READING					ANNUAL CHECK
			1000 km (600 mi)	10000 km (6000 mi)	20000 km (12000 mi)	30000 km (18000 mi)	40000 km (24000 mi)	
20	Sidestand	<ul style="list-style-type: none"> <li>Check operation.</li> <li>Lubricate with lithium-soap-based grease.</li> </ul>		√	√	√	√	√
21	* Sidestand switch	<ul style="list-style-type: none"> <li>Check operation and replace if necessary.</li> </ul>	√	√	√	√	√	√
22	* Front fork	<ul style="list-style-type: none"> <li>Check operation and for oil leakage.</li> <li>Replace if necessary.</li> </ul>		√	√	√	√	
23	* Shock absorber assembly	<ul style="list-style-type: none"> <li>Check operation and for oil leakage.</li> <li>Replace if necessary.</li> </ul>		√	√	√	√	
24	* Rear suspension relay arm and connecting arm pivoting points	<ul style="list-style-type: none"> <li>Check operation.</li> </ul>		√	√	√	√	
25	Engine oil	<ul style="list-style-type: none"> <li>Change (warm engine before draining).</li> <li>Check oil level and vehicle for oil leakage.</li> </ul>	√	√	√	√	√	√
26	Engine oil filter cartridge	<ul style="list-style-type: none"> <li>Replace.</li> </ul>	√		√		√	
27	* Cooling system	<ul style="list-style-type: none"> <li>Check coolant level and vehicle for coolant leakage.</li> </ul>		√	√	√	√	√
		<ul style="list-style-type: none"> <li>Change.</li> </ul>	Every 3 years					
28	* EXUP system	<ul style="list-style-type: none"> <li>Check operation, cable free play and pulley position.</li> </ul>	√		√		√	
29	* Front and rear brake switches	<ul style="list-style-type: none"> <li>Check operation.</li> </ul>	√	√	√	√	√	√



# Periodic maintenance and adjustment

NO.	ITEM	CHECK OR MAINTENANCE JOB	ODOMETER READING					ANNUAL CHECK
			1000 km (600 mi)	10000 km (6000 mi)	20000 km (12000 mi)	30000 km (18000 mi)	40000 km (24000 mi)	
30	* Moving parts and cables	• Lubricate.		√	√	√	√	√
31	* Throttle grip	• Check operation. • Lubricate throttle grip housing tube guides.		√	√	√	√	√
32	* Lights, signals and switches	• Check operation. • Adjust headlight beam.	√	√	√	√	√	√

EAU72811

## TIP

- Air filter
  - This model's air filter uses a disposable oil-coated paper element. This element cannot be cleaned with compressed air, doing so will only damage it.
  - The air filter element needs to be replaced more frequently when riding in unusually wet or dusty areas.
- Hydraulic brake service
  - Regularly check the front and rear brake fluid levels. Replenish if necessary.
  - Every two years replace the rear brake master cylinder, the internal components of the front brake master cylinder, the brake calipers, and change the brake fluid.
  - Replace the brake hoses every four years or sooner if cracked, damaged, or if any section of the stainless steel brake hose has turned black.

# Periodic maintenance and adjustment

EAU18713

## Removing and installing cowlings and panels

The cowlings and panels shown need to be removed to perform some of the maintenance jobs described in this chapter. Refer to this section each time a cowling or panel needs to be removed and installed.

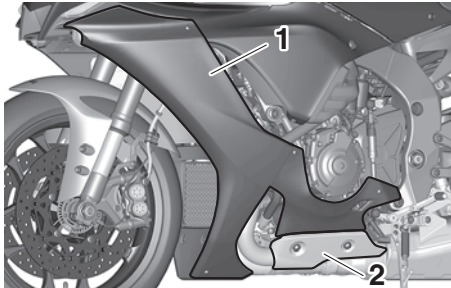

1. Cowling A
2. Panel C

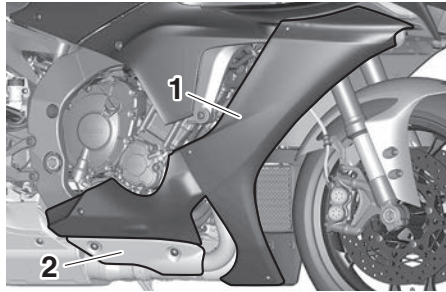

1. Cowling B
2. Panel D

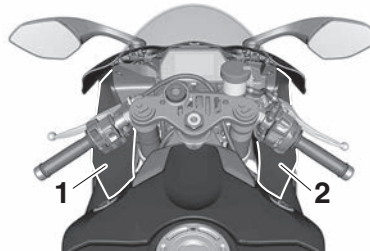

1. Panel A
2. Panel B

EAU88440

## Cowlings A and B (for YZF-R1)

### To remove a cowling

1. Remove the panel. (See page 7-11.)
2. Remove the quick fasteners, and then take the cowling off.

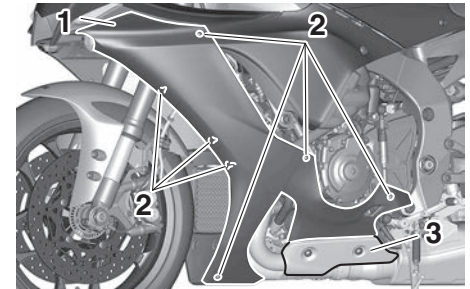

1. Cowling A
2. Quick fastener
3. Panel C

# Periodic maintenance and adjustment

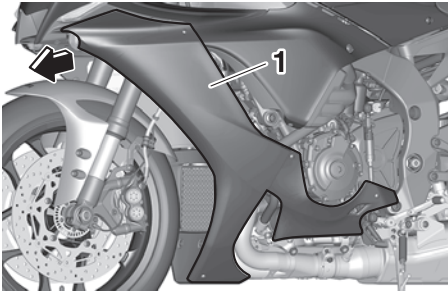

1. Cowling A

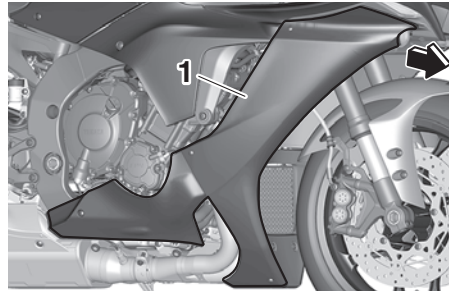

1. Cowling B

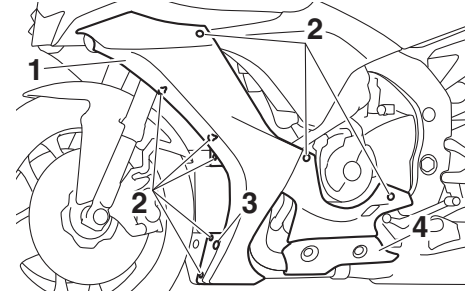

1. Cowling A
2. Quick fastener
3. Bolt and collar
4. Panel C

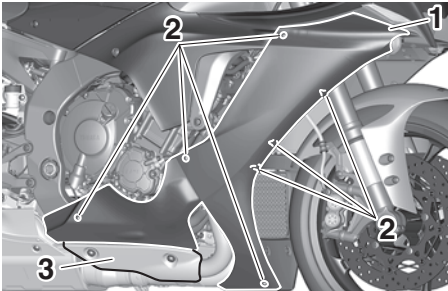

1. Cowling B
2. Quick fastener
3. Panel D

## To install a cowling

1. Place the cowling in its original position, and then install the quick fasteners.
2. Install the panel.

## **Cowlings A and B (for YZF-R1M)**

## To remove a cowling

1. Remove the panel. (See page 7-11.)
2. Remove the bolt, collar, and quick fasteners, and then take the cowling off.

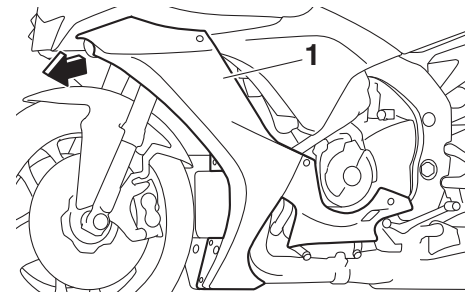

1. Cowling A

# Periodic maintenance and adjustment

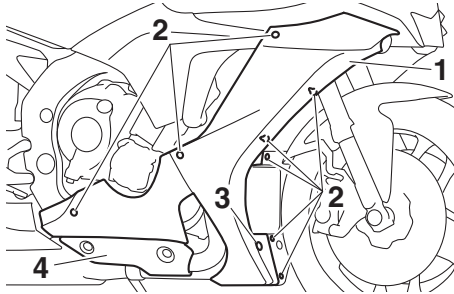

1. Cowling B
2. Quick fastener
3. Bolt and collar
4. Panel D

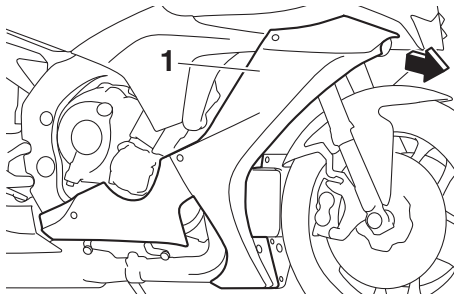

1. Cowling B

## To install a cowling

1. Place the cowling in its original position, and then install the collar, bolt, and quick fasteners.

2. Install the panel.

EAU66984

## **Panels A and B**

### To remove a panel

Remove the quick fastener and bolt, and then pull the panel off.

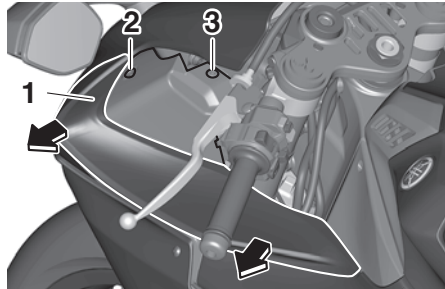

1. Panel A
2. Bolt
3. Quick fastener

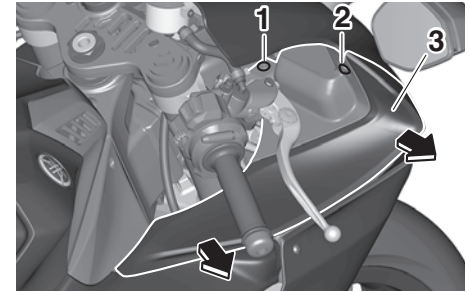

1. Quick fastener
2. Bolt
3. Panel B

### To install the panel

Place the panel in the original position, and then install the quick fastener and bolt.

## **Panels C and D**

### To remove a panel

Remove the bolts and washers, and then pull the panel off.

# Periodic maintenance and adjustment

EAU67110

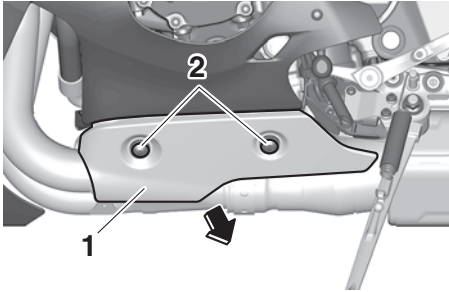

1. Panel C
2. Bolt and washer

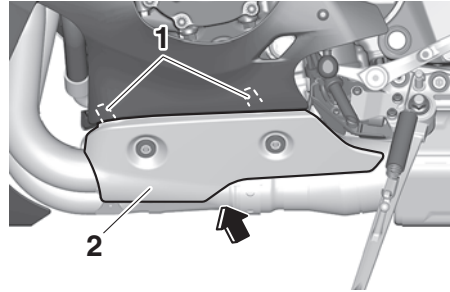

1. Projection
2. Panel C

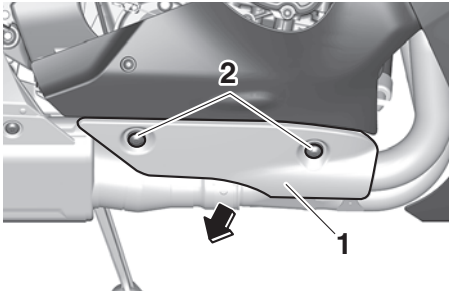

1. Panel D
2. Bolt and washer

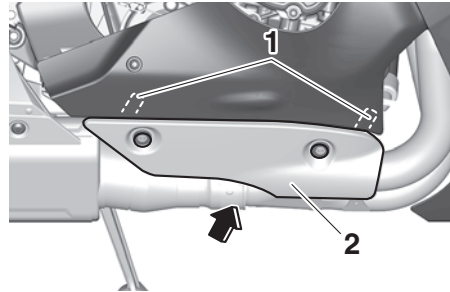

1. Projection
2. Panel D

2. Install the washers and bolts.

## To install the panel

1. Insert the projections into the holders as shown, and then place the panel in the original position.

## Checking the spark plugs

The spark plugs are important engine components, which should be checked periodically, preferably by a Yamaha dealer. Since heat and deposits will cause any spark plug to slowly erode, they should be removed and checked in accordance with the periodic maintenance and lubrication chart. In addition, the condition of the spark plugs can reveal the condition of the engine.

The porcelain insulator around the center electrode of each spark plug should be a medium-to-light tan (the ideal color when the vehicle is ridden normally), and all spark plugs installed in the engine should have the same color. If any spark plug shows a distinctly different color, the engine could be operating improperly. Do not attempt to diagnose such problems yourself. Instead, have a Yamaha dealer check the vehicle.

If a spark plug shows signs of electrode erosion and excessive carbon or other deposits, it should be replaced.

# Periodic maintenance and adjustment

**Specified spark plug:**  
NGK/LMAR9E-J

Before installing a spark plug, the spark plug gap should be measured with a wire thickness gauge and, if necessary, adjusted to specification.

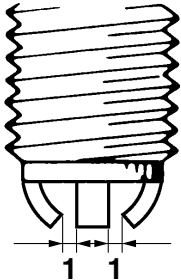

1. Spark plug gap

**Spark plug gap:**  
0.6–0.7 mm (0.024–0.028 in)

Clean the surface of the spark plug gasket and its mating surface, and then wipe off any grime from the spark plug threads.

**Tightening torque:**  
Spark plug (new):  
18 N·m (1.8 kgf·m, 13 lb·ft)  
Spark plug (after checking):  
13 N·m (1.3 kgf·m, 9.6 lb·ft)

ECA10841

## NOTICE

**Do not use any tools to remove or install the spark plug cap, otherwise the ignition coil coupler may get damaged. The spark plug cap may be difficult to remove because the rubber seal on the end of the cap fits tightly. To remove the spark plug cap, simply twist it back and forth while pulling it out; to install it, twist it back and forth while pushing it in.**

## Canister

EAU36112

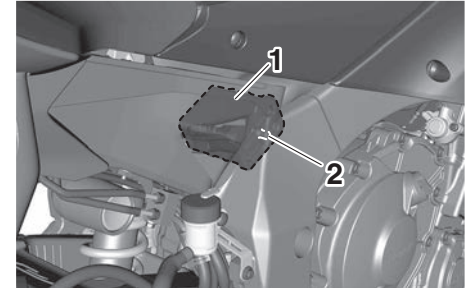

1. Canister
2. Canister breather

This model is equipped with a canister to prevent the discharging of fuel vapor into the atmosphere. Before operating this vehicle, make sure to check the following:

- Check each hose connection.
- Check each hose and canister for cracks or damage. Replace if damaged.
- Make sure that the canister breather is not blocked, and if necessary, clean it.

EAU66536

## Engine oil and oil filter cartridge

The engine oil level should be checked before each ride. In addition, the oil must be changed and the oil filter cartridge replaced at the intervals specified in the periodic maintenance and lubrication chart.

### To check the engine oil level

1. Place the vehicle on a level surface and hold it in an upright position. A slight tilt to the side can result in a false reading.
2. Start the engine, warm it up for several minutes, and then turn it off.
3. Wait a few minutes for the oil level to settle for an accurate reading, and then check the oil level through the check window located at the bottom-left side of the crankcase.

### TIP

The engine oil should be between the minimum and maximum level marks.

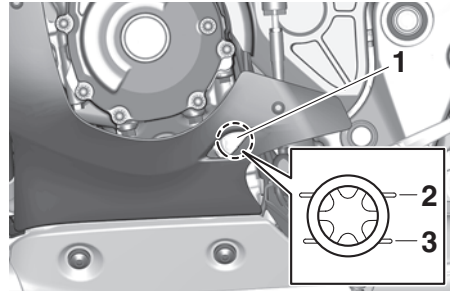

1. Engine oil level check window
2. Maximum level mark
3. Minimum level mark

4. If the engine oil is at or below the minimum level mark, add sufficient oil of the recommended type to raise it to the correct level.

### TIP

Check the oil filler cap O-ring for damage, and replace it if necessary.

### To change the engine oil

1. Start the engine, warm it up for several minutes, and then turn it off.
2. Place an oil pan under the engine to collect the used oil.

3. Remove the engine oil filler cap, the engine oil drain bolt and its gasket to drain the oil from the crankcase.

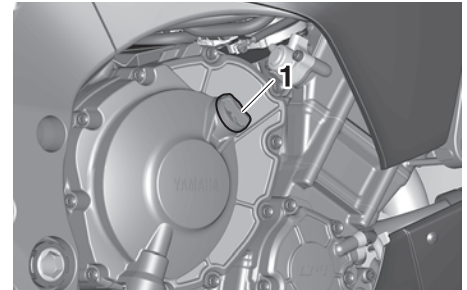

1. Engine oil filler cap

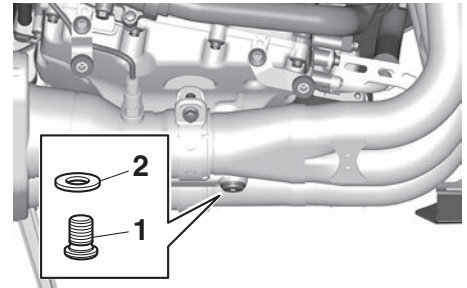

1. Engine oil drain bolt
2. Gasket

# Periodic maintenance and adjustment

4. Install the engine oil drain bolt and its new gasket, and then tighten the bolt to the specified torque.

## Tightening torque:

Engine oil drain bolt:  
23 N·m (2.3 kgf·m, 17 lb-ft)

5. Refill with the specified amount of the recommended engine oil.

## Recommended engine oil:

Full synthetic  
10W-40, 15W-50

## Oil quantity:

Oil change:  
3.90 L (4.12 US qt, 3.43 Imp.qt)  
With oil filter removal:  
4.10 L (4.33 US qt, 3.61 Imp.qt)

## TIP

Be sure to wipe off spilled oil on any parts after the engine and exhaust system have cooled down.

ECA11621

## NOTICE

- In order to prevent clutch slippage (since the engine oil also lubricates the clutch), do not mix any chemical additives. Do

**not use oils with a diesel specification of “CD” or oils of a higher quality than specified. In addition, do not use oils labeled “ENERGY CONSERVING II” or higher.**

- **Make sure that no foreign material enters the crankcase.**

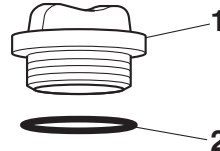

1. Engine oil filler cap
2. O-ring

6. Check the oil filler cap O-ring for damage, and replace it if necessary.
7. Install and tighten the oil filler cap.

8. Start the engine, and then let it idle for several minutes while checking it for oil leakage. If oil is leaking, immediately turn the engine off and check for the cause.

## TIP

After the engine is started, the oil pressure and coolant temperature warning light should go off if the oil level is sufficient.

ECA22490

## NOTICE

**If the oil pressure and coolant temperature warning light flickers or remains on even if the oil level is correct, immediately turn the engine off and have a Yamaha dealer check the vehicle.**

9. Turn the engine off, wait a few minutes for the oil level to settle for an accurate reading, and then check the oil level and correct it if necessary.



# Periodic maintenance and adjustment

## To change the engine oil and replace the oil filter cartridge

1. Remove cowling A and panel C. (See page 7-9.)
2. Follow steps 1–3 of the “To change the engine oil” section for the oil draining procedure.
3. Remove the oil filter cartridge with an oil filter wrench.

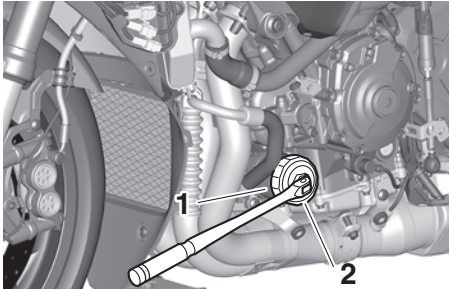

1. Oil filter cartridge
2. Oil filter wrench

### TIP

An oil filter wrench is available at a Yamaha dealer.

4. Apply a thin coat of clean engine oil to the O-ring of the new oil filter cartridge.

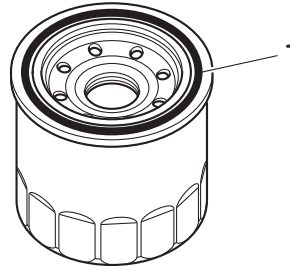

1. O-ring

### TIP

Make sure that the O-ring is properly seated.

5. Install the new oil filter cartridge with an oil filter wrench, and then tighten it to the specified torque with a torque wrench.

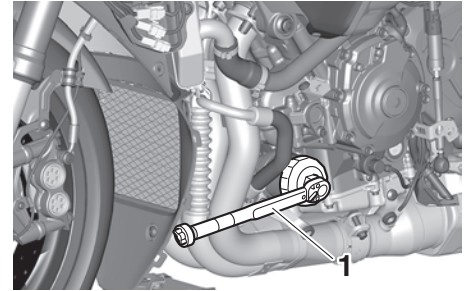

1. Torque wrench

### Tightening torque:

Oil filter cartridge:  
17 N·m (1.7 kgf·m, 13 lb·ft)

6. Follow steps 4–9 of the “To change the engine oil” section for the oil filling procedure.
7. Install the cowling and panel.

# Periodic maintenance and adjustment

7

## Why Yamalube

EAU85450

YAMALUBE oil is a Genuine YAMAHA Part born of the engineers' passion and belief that engine oil is an important liquid engine component. We form teams of specialists in the fields of mechanical engineering, chemistry, electronics and track testing, and have them develop the engine together with the oil it will use. Yamalube oils take full advantage of the base oil's qualities and blend in the ideal balance of additives to make sure the final oil clears our performance standards. Thus, Yamalube mineral, semisynthetic and synthetic oils have their own distinct characters and value. Yamaha's experience gained over many years of research and development into oil since the 1960's helps make Yamalube the best choice for your Yamaha engine.



## Coolant

EAU51203

The coolant level should be checked regularly. In addition, the coolant must be changed at the intervals specified in the periodic maintenance chart.

<p><b>Recommended coolant:</b> YAMALUBE coolant</p> <p><b>Coolant quantity:</b> Coolant reservoir (max level mark): 0.25 L (0.26 US qt, 0.22 Imp.qt) Radiator (including all routes): 2.25 L (2.38 US qt, 1.98 Imp.qt)</p>
--

### TIP

If genuine Yamaha coolant is not available, use an ethylene glycol antifreeze containing corrosion inhibitors for aluminum engines and mix with distilled water at a 1:1 ratio.

EAU66512

### To check the coolant level

Since the coolant level varies with engine temperature, check when the engine is cold.

1. Park the vehicle on a level surface.

2. With the vehicle in an upright position, look at the coolant level in the reservoir.

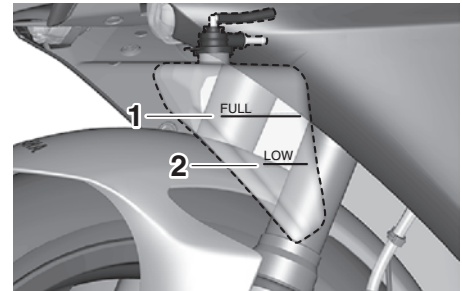

1. Maximum level mark
2. Minimum level mark

3. If the coolant is at or below the minimum level mark, remove cowling B to access the coolant reservoir. (See page 7-9.)
4. Remove the coolant reservoir cap. **WARNING! Remove only the coolant reservoir cap. Never attempt to remove the radiator cap when the engine is hot.**

[EWA15162]

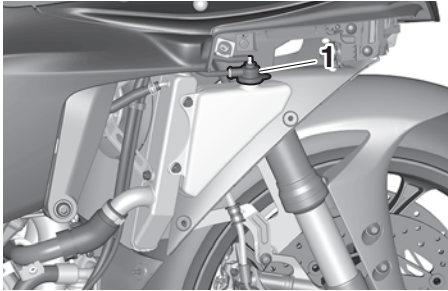

1. Coolant reservoir cap

5. Add coolant to the maximum level mark. **NOTICE: If coolant is not available, use distilled water or soft tap water instead. Do not use hard water or salt water since it is harmful to the engine. If water has been used instead of coolant, replace it with coolant as soon as possible, otherwise the cooling system will not be protected against frost and corrosion. If water has been added to the coolant, have a Yamaha dealer check the anti-freeze content of the coolant as soon as possible, otherwise the effectiveness of the coolant will be reduced.** [ECA10473]

6. Install the coolant reservoir cap.
7. Install the cowling.

EAU33032

## Changing the coolant

The coolant must be changed at the intervals specified in the periodic maintenance and lubrication chart. Have a Yamaha dealer change the coolant.

**WARNING! Never attempt to remove the radiator cap when the engine is hot.** [EWA10382]

EAU36765

## Air filter element

The air filter element must be replaced at the intervals specified in the periodic maintenance and lubrication chart. Have a Yamaha dealer replace the air filter element.

# Periodic maintenance and adjustment

## Checking the engine idling speed

EAU44735

Check the engine idling speed and, if necessary, have it corrected by a Yamaha dealer.

**Engine idling speed:**  
1200–1400 r/min

## Valve clearance

EAU21403

The valves are an important engine component, and since valve clearance changes with use, they must be checked and adjusted at the intervals specified in the periodic maintenance chart. Unadjusted valves can result in improper air-fuel mixture, engine noise, and eventually engine damage. To prevent this from occurring, have your Yamaha dealer check and adjust the valve clearance at regular intervals.

### TIP \_\_\_\_\_

This service must be performed when the engine is cold.

## Tires

EAU64412

Tires are the only contact between the vehicle and the road. Safety in all conditions of riding depends on a relatively small area of road contact. Therefore, it is essential to maintain the tires in good condition at all times and replace them at the appropriate time with the specified tires.

### Tire air pressure

The tire air pressure should be checked and, if necessary, adjusted before each ride.

EWA10504

### **WARNING** \_\_\_\_\_

Operation of this vehicle with improper tire pressure may cause severe injury or death from loss of control.

- The tire air pressure must be checked and adjusted on cold tires (i.e., when the temperature of the tires equals the ambient temperature).
- The tire air pressure must be adjusted in accordance with the riding speed and with the total

# Periodic maintenance and adjustment

EWA10472

weight of rider, passenger, cargo, and accessories approved for this model.

## Cold tire air pressure:

### 1 person:

Front:

250 kPa (2.50 kgf/cm<sup>2</sup>, 36 psi)

Rear:

290 kPa (2.90 kgf/cm<sup>2</sup>, 42 psi)

### 2 persons:

Front:

250 kPa (2.50 kgf/cm<sup>2</sup>, 36 psi)

Rear:

290 kPa (2.90 kgf/cm<sup>2</sup>, 42 psi)

## Maximum load:

Vehicle:

185 kg (408 lb)

The vehicle's maximum load is the combined weight of the rider, passenger, cargo, and any accessories.

EWA10512



## WARNING

Never overload your vehicle. Operation of an overloaded vehicle could cause an accident.

## Tire inspection

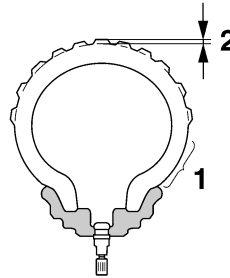

1. Tire sidewall
2. Tire tread depth

The tires must be checked before each ride. If the center tread depth reaches the specified limit, if the tire has a nail or glass fragments in it, or if the sidewall is cracked, have a Yamaha dealer replace the tire immediately.

## Minimum tire tread depth (front and rear):

1.6 mm (0.06 in)

## TIP

The tire tread depth limits may differ from country to country. Always comply with the local regulations.



## WARNING

- Have a Yamaha dealer replace excessively worn tires. Besides being illegal, operating the vehicle with excessively worn tires decreases riding stability and can lead to loss of control.
- The replacement of all wheel and brake-related parts, including the tires, should be left to a Yamaha dealer, who has the necessary professional knowledge and experience to do so.
- Ride at moderate speeds after changing a tire since the tire surface must first be “broken in” for it to develop its optimal characteristics.

# Periodic maintenance and adjustment

## Tire information

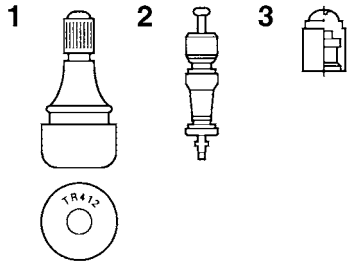

1. Tire air valve
2. Tire air valve core
3. Tire air valve cap with seal

This model is equipped with tubeless tires and tire air valves.

Tires age, even if they have not been used or have only been used occasionally. Cracking of the tread and sidewall rubber, sometimes accompanied by carcass deformation, is an evidence of ageing. Old and aged tires shall be checked by tire specialists to ascertain their suitability for further use.

EWA10902

### **WARNING**

- The front and rear tires should be of the same make and design, otherwise the handling

characteristics of the motorcycle may be different, which could lead to an accident.

- Always make sure that the valve caps are securely installed to prevent air pressure leakage.
- Use only the tire valves and valve cores listed below to avoid tire deflation during a ride.

After extensive tests, only the tires listed below have been approved for this model by Yamaha.

### Front tire:

Size:

120/70ZR17M/C (58W)

Manufacturer/model:

BRIDGESTONE/BATTLAX RACING STREET RS11F

### Rear tire:

Size:

190/55ZR17M/C (75W)

(YZF1000)

200/55ZR17M/C (78W)

(YZF1000D)

Manufacturer/model:

BRIDGESTONE/BATTLAX RACING STREET RS11R

### FRONT and REAR:

Tire air valve:

TR412

Valve core:

#9100 (original)

EWA10601

### **WARNING**

This motorcycle is fitted with super-high-speed tires. Note the following points in order to make the most efficient use of these tires.

- Use only the specified replacement tires. Other tires may run the danger of bursting at super high speeds.

- **Brand-new tires can have a relatively poor grip on certain road surfaces until they have been “broken in”. Therefore, it is advisable before doing any high-speed riding to ride conservatively for approximately 100 km (60 mi) after installing a new tire.**
- **The tires must be warmed up before a high-speed run.**
- **Always adjust the tire air pressure according to the operating conditions.**

## Cast magnesium wheels

EAU66460

To maximize the performance, durability, and safe operation of your motorcycle, note the following points regarding these wheels.

- The wheel rims should be checked for cracks, bends, warpage or damage before each ride. If any damage is found, have a Yamaha dealer replace the wheel. Do not attempt even the smallest repair to the wheel. A deformed or cracked wheel must be replaced.
- The wheel should be balanced whenever the tire or wheel has been changed or replaced. An unbalanced wheel can result in poor performance, adverse handling characteristics, and shortened tire life.

These wheels are made of magnesium and require special care.

- When balancing the wheel, use press-on type weights to avoid scratching the wheel.

- Regularly inspect the wheel for nicks and scratches. Use touch-up paint or other sealant to prevent corrosion.
- Follow the instructions for cleaning provided on page 8-1.

# Periodic maintenance and adjustment

EAU67342

## Adjusting the clutch lever free play

Measure the clutch lever free play as shown.

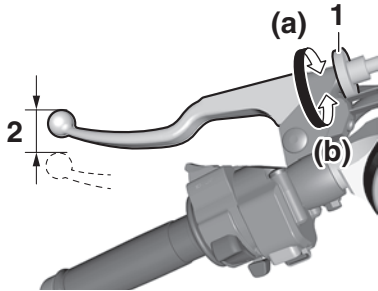

1. Clutch lever free play adjusting bolt
2. Clutch lever free play

**Clutch lever free play:**  
10.0–15.0 mm (0.39–0.59 in)

Periodically check the clutch lever free play and, if necessary, adjust it as follows.

To increase the clutch lever free play, turn the clutch lever free play adjusting bolt at the clutch lever in direction (a). To decrease the clutch lever free play, turn the adjusting bolt in direction (b).

### TIP

If the specified clutch lever free play cannot be obtained as described above, proceed as follows.

1. Fully turn the adjusting bolt at the clutch lever in direction (a) to loosen the clutch cable.
2. Remove cowling B. (See page 7-9.)
3. Loosen the locknut further down the clutch cable.
4. To increase the clutch lever free play, turn the clutch lever free play adjusting nut in direction (a). To decrease the clutch lever free play, turn the adjusting nut in direction (b).

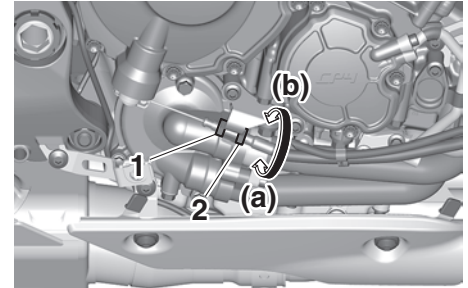

1. Locknut
2. Clutch lever free play adjusting nut

5. Tighten the locknut.
6. Install the cowling.



## Checking the brake lever free play

EAU37914

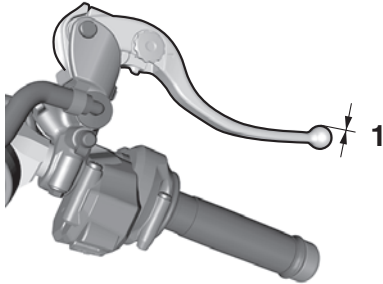

1. No brake lever free play

There should be no free play at the brake lever end. If there is free play, have a Yamaha dealer inspect the brake system.

EWA14212

### **! WARNING**

**A soft or spongy feeling in the brake lever can indicate the presence of air in the hydraulic system. If there is air in the hydraulic system, have a Yamaha dealer bleed the system before operating the vehicle. Air in the hydraulic system will diminish the**

**braking performance, which may result in loss of control and an accident.**

---

## Brake light switches

EAU36505

The brake light should come on just before braking takes effect. The brake light is activated by switches connected to the brake lever and brake pedal. Since the brake light switches are components of the anti-lock brake system, they should only be serviced by a Yamaha dealer.

# Periodic maintenance and adjustment

## Checking the front and rear brake pads

EAU22393

The front and rear brake pads must be checked for wear at the intervals specified in the periodic maintenance and lubrication chart.

### Front brake pads

EAU36891

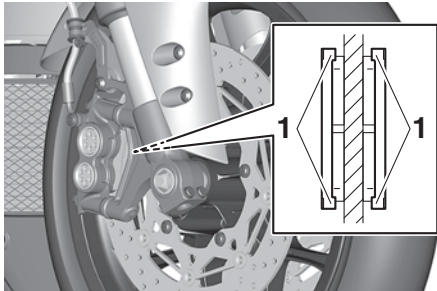

1. Brake pad wear indicator

Each front brake pad is provided with wear indicators, which allows you to check the brake pad wear without having to disassemble the brake. To check the brake pad wear, check the position of the wear indicators while applying the brake. If a brake pad has worn to the point that a wear indicator almost

touches the brake disc, have a Yamaha dealer replace the brake pads as a set.

### Rear brake pads

EAU46292

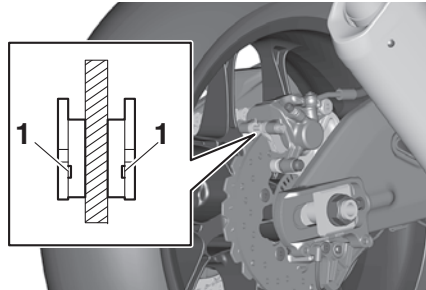

1. Brake pad wear indicator groove

Each rear brake pad is provided with wear indicator grooves, which allow you to check the brake pad wear without having to disassemble the brake. To check the brake pad wear, check the wear indicator grooves. If a brake pad has worn to the point that a wear indicator groove almost appears, have a Yamaha dealer replace the brake pads as a set.

## Checking the brake fluid level

EAU22583

Before riding, check that the brake fluid is above the minimum level mark. Check the brake fluid level with the reservoir in an upright position. Replenish the brake fluid if necessary.

**Specified brake fluid:**  
DOT 4

ECA17641

### NOTICE

**Brake fluid may damage painted surfaces or plastic parts. Always clean up spilled fluid immediately.**

### Front brake

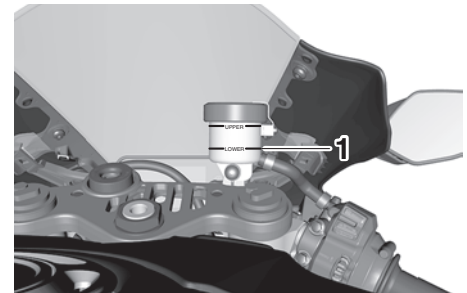

1. Minimum level mark

## Rear brake

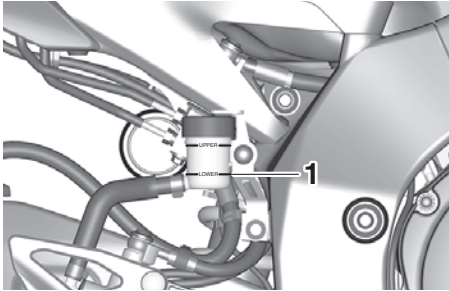

1. Minimum level mark

As the brake pads wear, it is normal for the brake fluid level to gradually go down.

- A low brake fluid level may indicate worn brake pads or brake system leakage; therefore, be sure to check the brake pads for wear and the brake system for leakage.
- If the brake fluid level goes down suddenly, have a Yamaha dealer check the cause before further riding.

EWA15991

### **WARNING**

**Improper maintenance can result in loss of braking ability. Observe these precautions:**

- **Insufficient brake fluid may allow air to enter the brake system, reducing braking performance.**
- **Clean the filler cap before removing. Use only DOT 4 brake fluid from a sealed container.**
- **Use only the specified brake fluid; otherwise, the rubber seals may deteriorate, causing leakage.**
- **Refill with the same type of brake fluid. Adding a brake fluid other than DOT 4 may result in a harmful chemical reaction.**
- **Be careful that water does not enter the brake fluid reservoir when refilling. Water will significantly lower the boiling point of the fluid and may result in vapor lock.**

## Changing the brake fluid

Have a Yamaha dealer change the brake fluid every 2 years. In addition, have the seals of the master cylinders and brake calipers, as well as the brake hoses replaced at the intervals listed below or sooner if they are damaged or leaking.

- Brake seals: every 2 years
- Brake hoses: every 4 years

# Periodic maintenance and adjustment

## Drive chain slack

EAU22762

The drive chain slack should be checked before each ride and adjusted if necessary.

### To check the drive chain slack

EAU2277G

1. Place the motorcycle on the side-stand.

### TIP

When checking and adjusting the drive chain slack, there should be no weight on the motorcycle.

2. Shift the transmission into the neutral position.
3. Measure the drive chain slack as shown.

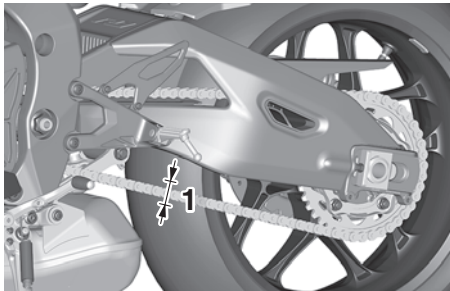

1. Drive chain slack

### Drive chain slack:

25.0–35.0 mm (0.98–1.38 in)

4. If the drive chain slack is incorrect, adjust it as follows. **NOTICE: Improper drive chain slack will overload the engine as well as other vital parts of the motorcycle and can lead to chain slippage or breakage. If the drive chain slack is more than 35.0 mm (1.38 in), the chain can damage the frame, swingarm, and other parts. To prevent this from occurring, keep the drive chain slack within the specified limits.**

[ECA17791]

EAU74260

### To adjust the drive chain slack

Consult a Yamaha dealer before adjusting the drive chain slack.

1. Loosen the axle nut and the locknut on each side of the swingarm.

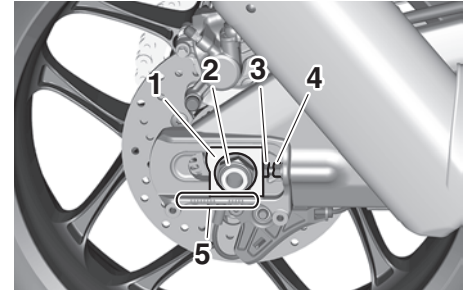

1. Drive chain puller
2. Axle nut
3. Drive chain slack adjusting bolt
4. Locknut
5. Alignment marks

2. To tighten the drive chain, turn the drive chain slack adjusting bolt on each side of the swingarm in direction (a). To loosen the drive chain, turn the adjusting bolt on each side of the swingarm in direction (b), and then push the rear wheel forward.

# Periodic maintenance and adjustment

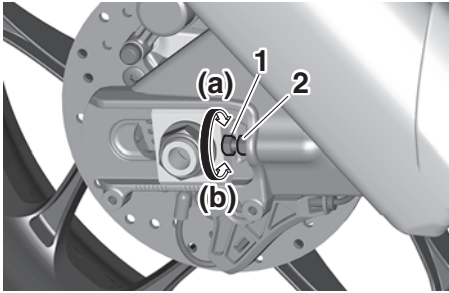

1. Drive chain slack adjusting bolt
2. Locknut

## TIP

Using the alignment marks on each side of the swingarm, make sure that both drive chain pullers are in the same position for proper wheel alignment.

3. Tighten the axle nut, then the locknuts to their specified torques.

### Tightening torques:

- Axle nut:  
190 N·m (19 kgf·m, 140 lb·ft)  
Locknut:  
16 N·m (1.6 kgf·m, 12 lb·ft)

4. Make sure that the drive chain pullers are in the same position, the drive chain slack is correct, and the drive chain moves smoothly.

## Cleaning and lubricating the drive chain

EAU23026

The drive chain must be cleaned and lubricated at the intervals specified in the periodic maintenance and lubrication chart, otherwise it will quickly wear out, especially when riding in dusty or wet areas. Service the drive chain as follows.

ECA10584

### NOTICE

**The drive chain must be lubricated after washing the motorcycle, riding in the rain or riding in wet areas.**

1. Clean the drive chain with kerosene and a small soft brush.  
**NOTICE: To prevent damaging the O-rings, do not clean the drive chain with steam cleaners, high-pressure washers or inappropriate solvents.** [ECA11122]
2. Wipe the drive chain dry.
3. Thoroughly lubricate the drive chain with a special O-ring chain lubricant. **NOTICE: Do not use engine oil or any other lubricants for the drive chain, as they**

# Periodic maintenance and adjustment

---

may contain substances that could damage the O-rings.

[ECA11112]

## Checking and lubricating the cables

EAU23098

The operation of all control cables and the condition of the cables should be checked before each ride, and the cables and cable ends should be lubricated if necessary. If a cable is damaged or does not move smoothly, have a Yamaha dealer check or replace it. **WARNING! Damage to the outer housing of cables may result in internal rusting and cause interference with cable movement. Replace damaged cables as soon as possible to prevent unsafe conditions.** [EWA10712]

### Recommended lubricant:

Yamaha cable lubricant or other suitable cable lubricant

## Checking and lubricating the throttle grip

EAU82490

The operation of the throttle grip should be checked before each ride. In addition, the throttle grip housing should be lubricated by a Yamaha dealer at the intervals specified in the periodic maintenance chart.

# Periodic maintenance and adjustment

## Checking and lubricating the brake and shift pedals EAU88560

The operation of the brake and shift pedals should be checked before each ride, and the pedal pivots should be lubricated if necessary.

### Brake pedal

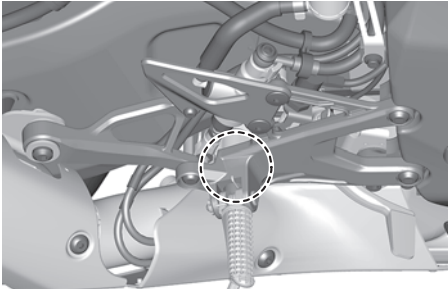

### Shift pedal

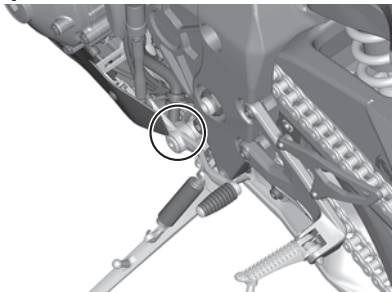

### Recommended lubricants:

Brake pedal:

Lithium-soap-based grease

Shift pedal:

Molybdenum disulfide grease

## Checking and lubricating the brake and clutch levers EAU23144

The operation of the brake and clutch levers should be checked before each ride, and the lever pivots should be lubricated if necessary.

### Brake lever

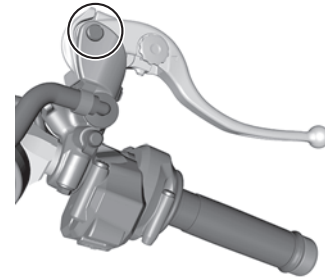

### Clutch lever

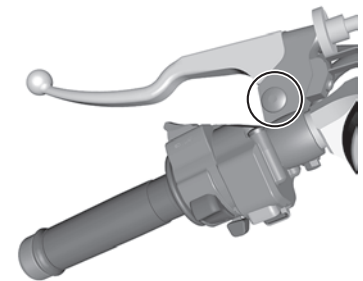

# Periodic maintenance and adjustment

## Recommended lubricants:

- Brake lever:
  - Silicone grease
- Clutch lever:
  - Lithium-soap-based grease

## Checking and lubricating the sidestand

EAU23203

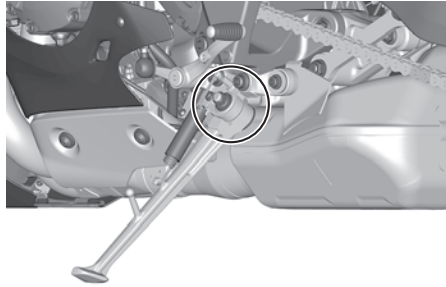

The operation of the sidestand should be checked before each ride, and the sidestand pivot and metal-to-metal contact surfaces should be lubricated if necessary.

### **WARNING**

EWA10732

**If the sidestand does not move up and down smoothly, have a Yamaha dealer check or repair it. Otherwise, the sidestand could contact the ground and distract the operator, resulting in a possible loss of control.**

**Recommended lubricant:**  
Lithium-soap-based grease

## Lubricating the swingarm pivots

EAUM1653

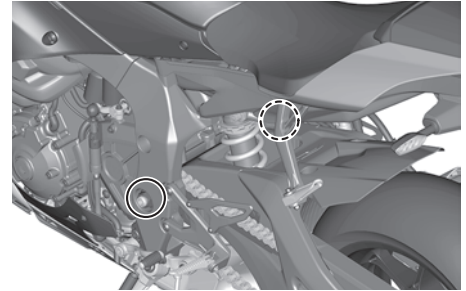

The swingarm pivots must be lubricated by a Yamaha dealer at the intervals specified in the periodic maintenance and lubrication chart.

**Recommended lubricant:**  
Lithium-soap-based grease



EAU23273

## Checking the front fork

The condition and operation of the front fork must be checked as follows at the intervals specified in the periodic maintenance and lubrication chart.

### To check the condition

Check the inner tubes for scratches, damage and excessive oil leakage.

### To check the operation

1. Place the vehicle on a level surface and hold it in an upright position. **WARNING! To avoid injury, securely support the vehicle so there is no danger of it falling over.** [EWA10752]
2. While applying the front brake, push down hard on the handlebars several times to check if the front fork compresses and rebounds smoothly.

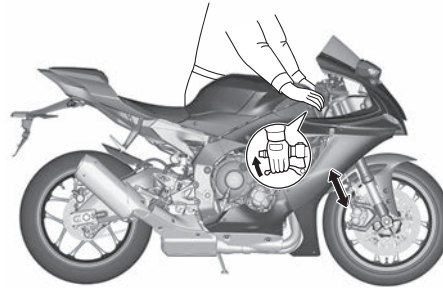

ECA10591

### NOTICE

**If any damage is found or the front fork does not operate smoothly, have a Yamaha dealer check or repair it.**

EAU23285

## Checking the steering

Worn or loose steering bearings may cause danger. Therefore, the operation of the steering must be checked as follows at the intervals specified in the periodic maintenance and lubrication chart.

1. Raise the front wheel off the ground. (See page 7-38.) **WARNING! To avoid injury, securely support the vehicle so there is no danger of it falling over.** [EWA10752]
2. Hold the lower ends of the front fork legs and try to move them forward and backward. If any free play can be felt, have a Yamaha dealer check or repair the steering.

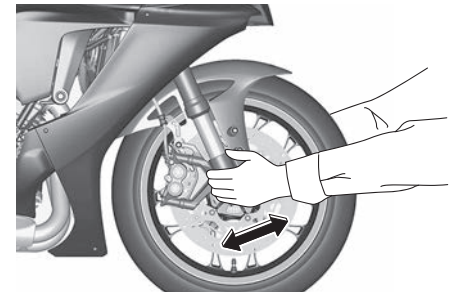

# Periodic maintenance and adjustment

## Checking the wheel bearings

EAU23292

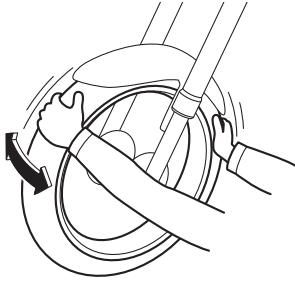

The front and rear wheel bearings must be checked at the intervals specified in the periodic maintenance and lubrication chart. If there is play in the wheel hub or if the wheel does not turn smoothly, have a Yamaha dealer check the wheel bearings.

7

## Battery

EAU68231

ECA22960

### NOTICE

Use only the specified genuine YAMAHA battery. Using a different battery may cause the IMU to fail and the engine to stall.

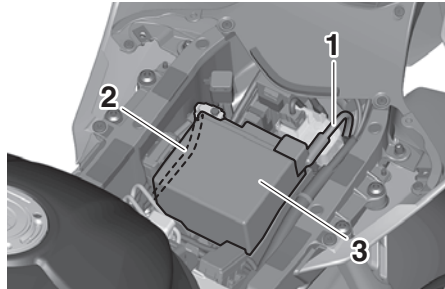

1. Positive battery lead (red)
2. Negative battery lead (black)
3. Battery

The battery is located under the rider seat. (See page 4-38.)

ECA22970

### NOTICE

The IMU is located under the battery. It is not user serviceable and very sensitive, so we advise against removing the battery box or handling the IMU directly.

- Do not remove, modify, or place any foreign materials in or around the battery box.
- Do not subject the IMU to strong shocks and be careful when handling the battery.
- Do not obstruct the IMU breather hole and do not clean it with compressed air.

This model is equipped with a VRLA (Valve Regulated Lead Acid) battery. There is no need to check the electrolyte or to add distilled water. However, the battery lead connections need to be checked and, if necessary, tightened.

# Periodic maintenance and adjustment

EWA10761

## WARNING

- **Electrolyte is poisonous and dangerous since it contains sulfuric acid, which causes severe burns. Avoid any contact with skin, eyes or clothing and always shield your eyes when working near batteries. In case of contact, administer the following FIRST AID.**
  - **EXTERNAL:** Flush with plenty of water.
  - **INTERNAL:** Drink large quantities of water or milk and immediately call a physician.
  - **EYES:** Flush with water for 15 minutes and seek prompt medical attention.
- **Batteries produce explosive hydrogen gas. Therefore, keep sparks, flames, cigarettes, etc., away from the battery and provide sufficient ventilation when charging it in an enclosed space.**

- **KEEP THIS AND ALL BATTERIES OUT OF THE REACH OF CHILDREN.**

### To charge the battery

Have a Yamaha dealer charge the battery as soon as possible if it seems to have discharged. Keep in mind that the battery tends to discharge more quickly if the vehicle is equipped with optional electrical accessories.

ECA16522

### NOTICE

**To charge a VRLA (Valve Regulated Lead Acid) battery, a special (constant-voltage) battery charger is required. Using a conventional battery charger will damage the battery.**

### To store the battery

1. If the vehicle will not be used for more than one month, remove the battery, fully charge it, and then place it in a cool, dry place.  
**NOTICE: When removing the battery, be sure to turn the main**

**switch off, then disconnect the negative lead before disconnecting the positive lead.** [ECA16304]

2. If the battery will be stored for more than two months, check it at least once a month and fully charge it if necessary.
3. Fully charge the battery before installation. **NOTICE: When installing the battery, be sure to turn the main switch off, then connect the positive lead before connecting the negative lead.**
4. After installation, make sure that the battery leads are properly connected to the battery terminals.

[ECA16842]

ECA16531

### NOTICE

**Always keep the battery charged. Storing a discharged battery can cause permanent battery damage.**

# Periodic maintenance and adjustment

EAU66593

## Replacing the fuses

The main fuse, the ABS motor fuse, and fuse box 1 are located under the rider seat. (See page 4-38.)

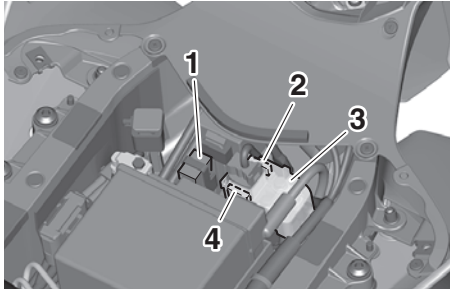

1. Main fuse
2. ABS motor fuse
3. Starter relay cover
4. ABS motor spare fuse

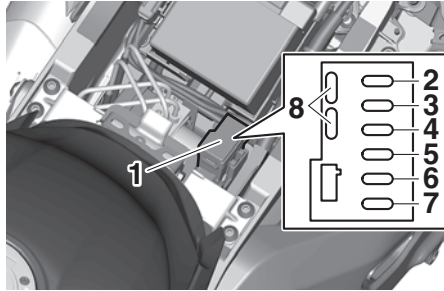

1. Fuse box 1
2. ABS solenoid fuse
3. Fuel injection system fuse
4. Electronic throttle valve fuse
5. Backup fuse (for clock and ECU)
6. Sub radiator fan motor fuse
7. Radiator fan motor fuse
8. Spare fuse

### To access the ABS motor fuse and fuse box 1

1. Remove the passenger seat and rider seat. (See page 4-38.)
2. Remove the battery cover by removing the bolts.

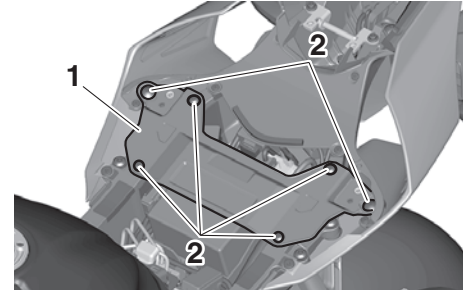

1. Battery cover
2. Bolt

3. Remove the panel by removing the quick fastener screws.

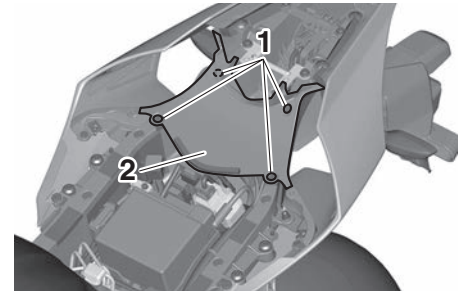

1. Quick fastener screw
2. Panel

# Periodic maintenance and adjustment

## TIP

To access the ABS motor fuse, remove the starter relay cover by pulling it upward.

Fuse box 2 is located under panel A. (See page 7-9.)

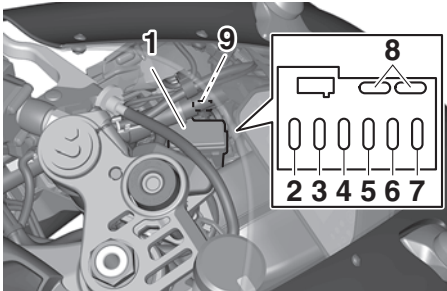

1. Fuse box 2
2. Terminal fuse 1
3. Headlight fuse
4. Hazard fuse
5. ABS ECU fuse
6. Signaling system fuse
7. Ignition fuse
8. Spare fuse
9. SCU fuse (YZF-R1M)

If a fuse is blown, replace it as follows.

1. Turn the key to “OFF” and turn off the electrical circuit in question.

2. Remove the blown fuse, and then install a new fuse of the specified amperage. **WARNING! Do not use a fuse of a higher amperage rating than recommended to avoid causing extensive damage to the electrical system and possibly a fire.** [EWA15132]

## Specified fuses:

- Main fuse:
  - 50.0 A
- Terminal fuse 1:
  - 2.0 A
- Headlight fuse:
  - 7.5 A
- Signaling system fuse:
  - 7.5 A
- Ignition fuse:
  - 15.0 A
- Radiator fan motor fuse:
  - 15.0 A
- Sub radiator fan motor fuse:
  - 10.0 A
- ABS motor fuse:
  - 30.0 A
- Hazard fuse:
  - 7.5 A
- ABS ECU fuse:
  - 7.5 A
- ABS solenoid fuse:
  - 15.0 A
- SCU fuse:
  - 7.5 A (YZF1000D)
- Fuel injection system fuse:
  - 15.0 A
- Backup fuse:
  - 7.5 A
- Electronic throttle valve fuse:
  - 7.5 A

# Periodic maintenance and adjustment

3. Turn the key to “ON” and turn on the electrical circuit in question to check if the device operates.
4. If the fuse immediately blows again, have a Yamaha dealer check the electrical system.

## Vehicle lights

EAU67122

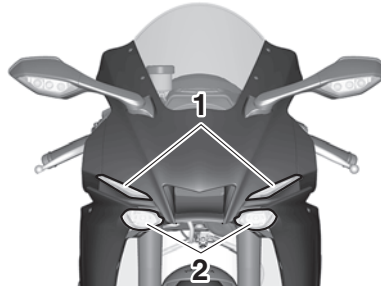

1. Auxiliary light
2. Headlight

This model is equipped with full-LED lighting.

The headlights, auxiliary lights, turn signals, brake/tail light, and license plate light are all LED. There are no user replaceable bulbs.



If a light does not come on, check the fuses and then have a Yamaha dealer check the vehicle.

ECA16581

### **NOTICE**

**Do not affix any type of tinted film or stickers to the headlight lens.**

### **TIP**

- The right headlight comes on when Pass/LAP switch “/LAP” is pushed or the dimmer switch is set to “” (high beam).
- The auxiliary lights were designed to fade out as your R1 goes to sleep.

## Supporting the motorcycle

EAU67131

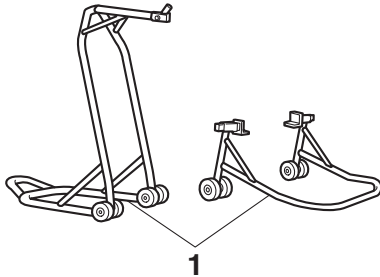

1. Maintenance stand (example)

Since this model is not equipped with a centerstand, use maintenance stands when removing the front or rear wheel or when performing other maintenance that requires the motorcycle to stand up right.

Check that the motorcycle is in a stable and level position before starting any maintenance.

## Troubleshooting

EAU25872

Although Yamaha motorcycles receive a thorough inspection before shipment from the factory, trouble may occur during operation. Any problem in the fuel, compression, or ignition systems, for example, can cause poor starting and loss of power.

The following troubleshooting charts represent quick and easy procedures for checking these vital systems yourself. However, should your motorcycle require any repair, take it to a Yamaha dealer, whose skilled technicians have the necessary tools, experience, and know-how to service the motorcycle properly.

Use only genuine Yamaha replacement parts. Imitation parts may look like Yamaha parts, but they are often inferior, have a shorter service life and can lead to expensive repair bills.

EWA15142

### **WARNING**

**When checking the fuel system, do not smoke, and make sure there are no open flames or sparks in the area, including pilot lights from water**

**heaters or furnaces. Gasoline or gasoline vapors can ignite or explode, causing severe injury or property damage.**

# Periodic maintenance and adjustment

EAU86350

## Troubleshooting chart

### 1. Fuel

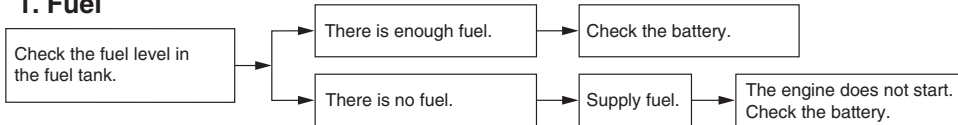

### 2. Battery

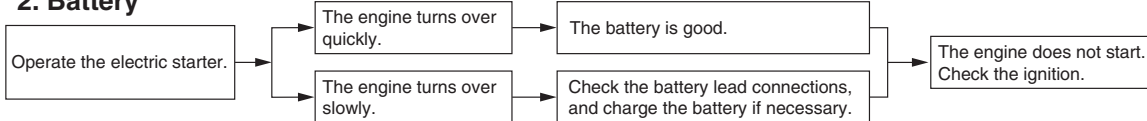

### 3. Ignition

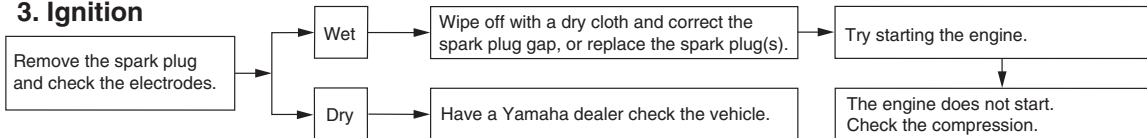

### 4. Compression

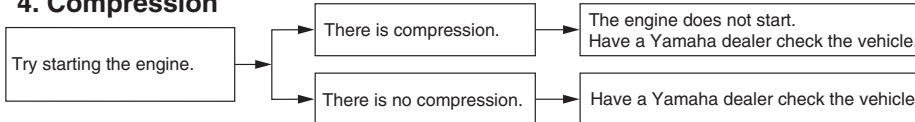



# Periodic maintenance and adjustment

EAU86420

## Engine overheating

EWAT1041

### **WARNING**

- Do not remove the radiator cap when the engine and radiator are hot. Scalding hot fluid and steam may be blown out under pressure, which could cause serious injury. Be sure to wait until the engine has cooled.
- Place a thick rag, like a towel, over the radiator cap, and then slowly rotate the cap counterclockwise to the detent to allow any residual pressure to escape. When the hissing sound has stopped, press down on the cap while turning it counterclockwise, and then remove the cap.

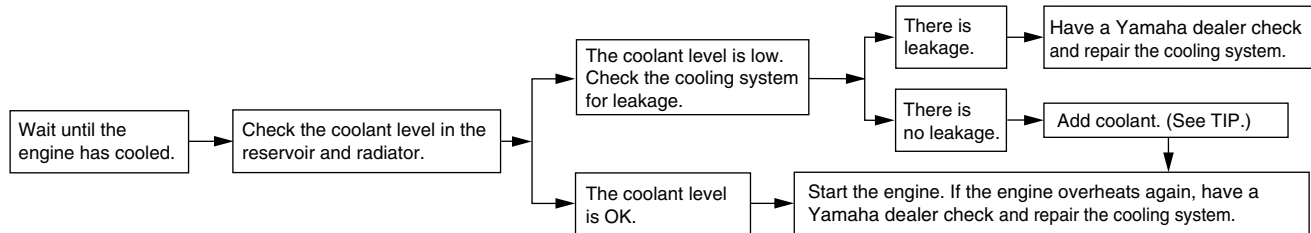

### **TIP**

If coolant is not available, tap water can be temporarily used instead, provided that it is changed to the recommended coolant as soon as possible.

# Motorcycle care and storage

---

## Matte color caution

EAU37834

ECA15193

### **NOTICE**

---

Some models are equipped with matte colored finished parts. Be sure to consult a Yamaha dealer for advice on what products to use before cleaning the vehicle. Using a brush, harsh chemical products or cleaning compounds when cleaning these parts will scratch or damage their surface. Wax also should not be applied to any matte colored finished parts.

---

## Care

EAU83443

Frequent, thorough cleaning of the vehicle will not only enhance its appearance but also will improve its general performance and extend the useful life of many components. Washing, cleaning, and polishing will also give you a chance to inspect the condition of the vehicle more frequently. Be sure to wash the vehicle after riding in the rain or near the sea, because salt is corrosive to metals.

### **TIP**

---

- The roads of heavy snowfall areas may be sprayed with salt as a de-icing method. This salt can stay on the roads well into spring, so be sure to wash the underside and chassis parts after riding in such areas.
  - Genuine Yamaha care and maintenance products are sold under the YAMALUBE brand in many markets worldwide.
  - See your Yamaha dealer for additional cleaning tips.
- 

ECA26280

### **NOTICE**

---

**Improper cleaning can cause cosmetic and mechanical damage. Do not use:**

- high-pressure washers or steam-jet cleaners. Excessive water pressure may cause water seepage and deterioration of wheel bearings, brakes, transmission seals and electrical devices. Avoid high-pressure detergent applications such as those available in coin-operated car washers.
- harsh chemicals, including strong acidic wheel cleaners, especially on spoke or magnesium wheels.
- harsh chemicals, abrasive cleaning compounds, or wax on matte-finished parts. Brushes can scratch and damage the matte-finish, use soft sponge or towel only.
- towels, sponges, or brushes contaminated with abrasive cleaning products or strong

chemicals such as, solvents, gasoline, rust removers, brake fluid, or antifreeze, etc.

## Before washing

1. Park the vehicle out of direct sunlight and allow it to cool. This will help avoid water spots.
2. Make sure all caps, covers, electrical couplers and connectors are tightly installed.
3. Cover the muffler end with a plastic bag and a strong rubber band.
4. Pre-soak stubborn stains like insects or bird droppings with a wet towel for a few minutes.
5. Remove road grime and oil stains with a quality degreasing agent and a plastic-bristle brush or sponge. **NOTICE: Do not use degreasing agent on areas requiring lubrication such as seals, gaskets, and wheel axles. Follow product instructions.**

[ECA26290]

## Washing

1. Rinse off any degreaser and spray down the vehicle with a garden hose. Use only enough pressure to do the job. Avoid spraying water directly into the muffler, instrument panel, air inlet, or other inner areas such as underseat storage compartments.
2. Wash the vehicle with a quality automotive-type detergent mixed with cool water and a soft, clean towel or sponge. Use an old toothbrush or plastic-bristle brush for hard-to-reach places. **NOTICE: Use cold water if the vehicle has been exposed to salt. Warm water will increase salt's corrosive properties.** [ECA26301]
3. For windshield-equipped vehicles: Clean the windshield with a soft towel or sponge dampened with water and a pH neutral detergent. If necessary, use a high-quality windshield cleaner or polish for motorcycles. **NOTICE: Never use any strong chemicals to clean the windshield. Additionally, some cleaning compounds for**

plastic may scratch the windshield, so be sure to test all cleaning products before general application.

[ECA26310]

4. Rinse off thoroughly with clean water. Be sure to remove all detergent residues, as they can be harmful to plastic parts.

## After washing

1. Dry the vehicle with a chamois or absorbent towel, preferably microfiber terrycloth.
2. For drive chain-equipped models: Dry and then lubricate the drive chain to prevent rust.
3. Use a chrome polish to shine chrome, aluminum, and stainless steel parts. Often the thermally induced discoloring of stainless steel exhaust systems can be removed through polishing.
4. Apply a corrosion protection spray on all metal parts including chrome or nickel-plated surfaces. **WARNING! Do not apply silicone or oil spray to seats, hand grips, rubber foot pegs or tire treads. Otherwise these parts**

# Motorcycle care and storage

will become slippery, which could cause loss of control. Thoroughly clean the surfaces of these parts before operating the vehicle. [EWA20650]

5. Treat rubber, vinyl, and unpainted plastic parts with a suitable care product.
6. Touch up minor paint damage caused by stones, etc.
7. Wax all painted surfaces using a non-abrasive wax or use a detail spray for motorcycles.
8. When finished cleaning, start the engine and let it idle for several minutes to help dry any remaining moisture.
9. If the headlight lens has fogged up, start the engine and turn on the headlight to help remove the moisture.
10. Let the vehicle dry completely before storing or covering it.

ECA26320

## NOTICE

- Do not apply wax to rubber or unpainted plastic parts.

- Do not use abrasive polishing compounds as they will wear away the paint.
- Apply sprays and wax sparingly. Wipe off excess afterwards.

EWA20660

## WARNING

**Contaminants left on the brakes or tires can cause loss of control.**

- Make sure there is no lubricant or wax on the brakes or tires.
- If necessary, wash the tires with warm water and a mild detergent.
- If necessary, clean the brake discs and pads with brake cleaner or acetone.
- Before riding at higher speeds, test the vehicle's braking performance and cornering behavior.

EAU83450

## Cleaning the titanium muffler

This model is equipped with a titanium muffler which requires special care. Use only a soft cloth or sponge and mild detergent with water to clean the muffler. This should remove finger-

prints and other oil stains. If necessary, an alkaline pH cleaning product and soft brush may be used. However, do not use abrasive compounds or special treatments to clean the muffler, as these will wear away the protective finish.

## TIP

The thermally induced discoloring of the exhaust pipe leading into the titanium muffler is normal and cannot be removed.

## Storage

Always store the vehicle in a cool, dry place. If necessary, protect it against dust with a porous cover. Be sure the engine and the exhaust system are cool before covering the vehicle. If the vehicle often sits for weeks at a time between uses, the use of a quality fuel stabilizer is recommended after each fill-up.

EAU83472

ECA21170

### NOTICE

- **Storing the vehicle in a poorly ventilated room or covering it with a tarp, while it is still wet, will allow water and humidity to seep in and cause rust.**
- **To prevent corrosion, avoid damp cellars, stables (because of the presence of ammonia) and areas where strong chemicals are stored.**

## Long term storage

Before storing the vehicle long term (60 days or more):

1. Make all necessary repairs and perform any outstanding maintenance.
  2. Follow all instructions in the Care section of this chapter.
  3. Fill up the fuel tank, adding fuel stabilizer according to product instructions. Run the engine for 5 minutes to distribute treated fuel through the fuel system.
  4. For vehicles equipped with a fuel cock: Turn the fuel cock lever to the off position.
  5. For vehicles with a carburetor: To prevent fuel deposits from building up, drain the fuel in the carburetor float chamber into a clean container. Retighten the drain bolt and pour the fuel back into the fuel tank.
  6. Use a quality engine fogging oil according to product instructions to protect internal engine components from corrosion. If engine fogging oil is not available, perform the following steps for each cylinder:
    - a. Remove the spark plug cap and spark plug.
    - b. Pour a teaspoonful of engine oil into the spark plug bore.
    - c. Install the spark plug cap onto the spark plug, and then place the spark plug on the cylinder head so that the electrodes are grounded. (This will limit sparking during the next step.)
    - d. Turn the engine over several times with the starter. (This will coat the cylinder wall with oil.)  
**WARNING! To prevent damage or injury from sparking, make sure to ground the spark plug electrodes while turning the engine over.**
- [EWA10952]
- e. Remove the spark plug cap from the spark plug, and then install the spark plug and the spark plug cap.
  7. Lubricate all control cables, pivots, levers and pedals, as well as the sidestand and centerstand (if equipped).
  8. Check and correct the tire air pressure, and then lift the vehicle so that all wheels are off the ground. Otherwise, turn the

# Motorcycle care and storage

---

wheels a little once a month in order to prevent the tires from becoming degraded in one spot.

9. Cover the muffler outlet with a plastic bag to prevent moisture from entering it.
10. Remove the battery and fully charge it, or attach a maintenance charger to keep the battery optimally charged. **NOTICE: Confirm that the battery and its charger are compatible. Do not charge a VRLA battery with a conventional charger.** [ECA26330]

## TIP

---

- If the battery will be removed, charge it once a month and store it in a temperate location between 0-30 °C (32-90 °F).
  - See page 7-33 for more information on charging and storing the battery.
-

## Dimensions:

- Overall length:  
2055 mm (80.9 in)
- Overall width:  
690 mm (27.2 in)
- Overall height:  
1165 mm (45.9 in)
- Seat height:  
855 mm (33.7 in) (YZF1000)  
860 mm (33.9 in) (YZF1000D)
- Wheelbase:  
1405 mm (55.3 in)
- Ground clearance:  
130 mm (5.12 in)
- Minimum turning radius:  
3.4 m (11.16 ft)

## Weight:

- Curb weight:  
201 kg (443 lb) (YZF1000)  
202 kg (445 lb) (YZF1000D)

## Engine:

- Combustion cycle:  
4-stroke
- Cooling system:  
Liquid cooled
- Valve train:  
DOHC
- Cylinder arrangement:  
Inline
- Number of cylinders:  
4-cylinder
- Displacement:  
998 cm<sup>3</sup>

- Bore × stroke:  
79.0 × 50.9 mm (3.11 × 2.00 in)
- Starting system:  
Electric starter

## Engine oil:

- Recommended brand:



- Type:  
Full synthetic
- SAE viscosity grades:  
10W-40, 15W-50
- Recommended engine oil grade:  
API service SG type or higher, JASO standard MA
- Engine oil quantity:  
Oil change:  
3.90 L (4.12 US qt, 3.43 Imp.qt)  
With oil filter removal:  
4.10 L (4.33 US qt, 3.61 Imp.qt)

## Coolant quantity:

- Coolant reservoir (up to the maximum level mark):  
0.25 L (0.26 US qt, 0.22 Imp.qt)
- Radiator (including all routes):  
2.25 L (2.38 US qt, 1.98 Imp.qt)

## Fuel:

- Recommended fuel:  
Unleaded gasoline (E10 acceptable)
- Octane number (RON):  
95

- Fuel tank capacity:  
17 L (4.5 US gal, 3.7 Imp.gal)
- Fuel reserve amount:  
3.0 L (0.79 US gal, 0.66 Imp.gal)

## Fuel injection:

- Throttle body:
- ID mark:  
B3L1 00

## Drivetrain:

- Gear ratio:  
1st:  
2.600 (39/15)  
2nd:  
2.176 (37/17)  
3rd:  
1.842 (35/19)  
4th:  
1.579 (30/19)  
5th:  
1.381 (29/21)  
6th:  
1.250 (30/24)

## Front tire:

- Type:  
Tubeless
- Size:  
120/70ZR17M/C (58W)
- Manufacturer/model:  
BRIDGESTONE/BATTLAX RACING  
STREET RS11F

## Rear tire:

- Type:  
Tubeless

# Specifications

---

## Size:

190/55ZR17M/C (75W) (YZF1000)  
200/55ZR17M/C (78W) (YZF1000D)

## Manufacturer/model:

BRIDGESTONE/BATTLAX RACING  
STREET RS11R

## Loading:

### Maximum load:

185 kg (408 lb)

The vehicle's maximum load is the combined weight of the rider, passenger, cargo and any accessories.

## Front brake:

### Type:

Hydraulic dual disc brake

## Rear brake:

### Type:

Hydraulic single disc brake

## Front suspension:

### Type:

Telescopic fork

## Rear suspension:

### Type:

Swingarm (link suspension)

## Electrical system:

### System voltage:

12 V

## Battery:

### Model:

YTZ7S(F)

### Voltage, capacity:

12 V, 6.0 Ah (10 HR)

## Bulb wattage:

### Headlight:

LED

### Brake/tail light:

LED

### Front turn signal light:

LED

### Rear turn signal light:

LED

### Auxiliary light:

LED

### License plate light:

LED



## Identification numbers

EAU53562

Record the vehicle identification number, engine serial number, and the model label information in the spaces provided below. These identification numbers are needed when registering the vehicle with the authorities in your area and when ordering spare parts from a Yamaha dealer.

VEHICLE IDENTIFICATION NUMBER:

ENGINE SERIAL NUMBER:

MODEL LABEL INFORMATION:

## Vehicle identification number

EAU26401

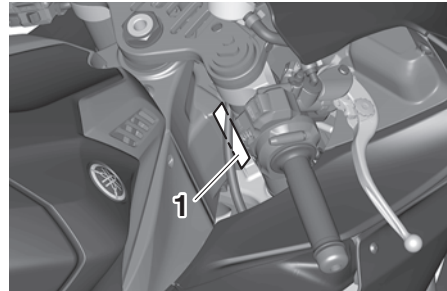

1. Vehicle identification number

The vehicle identification number is stamped into the steering head pipe. Record this number in the space provided.

### TIP

The vehicle identification number is used to identify your motorcycle and may be used to register your motorcycle with the licensing authority in your area.

## Engine serial number

EAU26442

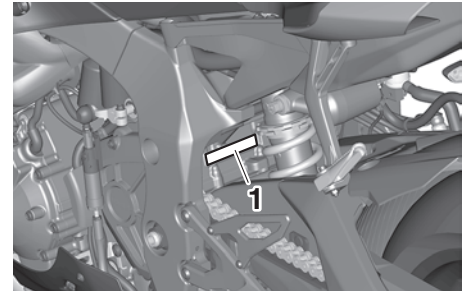

1. Engine serial number

The engine serial number is stamped into the crankcase.

## Model label

EAU26521

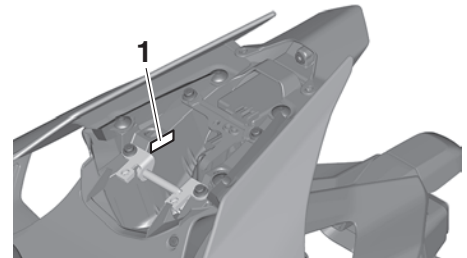

1. Model label

# Consumer information

The model label is affixed to the frame under the passenger seat. (See page 4-38.) Record the information on this label in the space provided. This information will be needed when ordering spare parts from a Yamaha dealer.

## Diagnostic connector

EAU69910

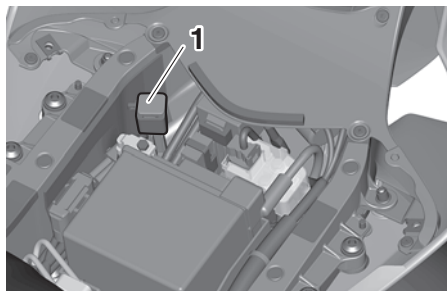

1. Diagnostic connector

The diagnostic connector is located as shown.

## Vehicle data recording

EAU85300

This model's ECU stores certain vehicle data to assist in the diagnosis of malfunctions and for research, statistical analysis and development purposes.

Although the sensors and recorded data will vary by model, the main data points are:

- Vehicle status and engine performance data
- Fuel-injection and emission-related data

This data will be uploaded only when a special Yamaha diagnostic tool is attached to the vehicle, such as when maintenance checks or service procedures are performed.

Vehicle data uploaded will be handled appropriately according to the following Privacy Policy.

### Privacy Policy

<https://www.yamaha-motor.eu/eu/privacy/privacy-policy.aspx>

Yamaha will not disclose this data to a third party except in the following cases. In addition, Yamaha may provide vehicle data to a contractor in order to outsource services related to the handling of vehicle data. Even in this case, Yamaha will require the contractor to properly handle the vehicle data we provided and Yamaha will appropriately manage the data.

- With the consent of the vehicle owner
- Where obligated by law
- For use by Yamaha in litigation
- When the data is not related to an individual vehicle nor owner

# Index

- A**  
ABS warning light ..... 4-7  
Air filter element ..... 7-18  
Auxiliary DC connector ..... 4-49  
Auxiliary system warning light ..... 4-8
- B**  
Battery ..... 7-33  
Brake and clutch levers, checking and lubricating ..... 7-30  
Brake and shift pedals, checking and lubricating ..... 7-30  
Brake control system (BC) ..... 4-33  
Brake fluid, changing ..... 7-26  
Brake fluid level, checking ..... 7-25  
Brake lever ..... 4-33  
Brake lever free play, checking ..... 7-24  
Brake light switches ..... 7-24  
Brake pedal ..... 4-33
- C**  
Cables, checking and lubricating ..... 7-29  
Canister ..... 7-13  
Care ..... 8-1  
Catalytic converter ..... 4-38  
CCU ..... 4-39  
Clutch lever ..... 4-32  
Clutch lever free play, adjusting ..... 7-23  
Coolant ..... 7-17  
Cowlings and panels, removing and installing ..... 7-9
- D**  
Data recording, vehicle ..... 10-2  
Diagnostic connector ..... 10-2  
Dimmer switch ..... 4-4  
Display, main screen ..... 4-9  
Display, menu screen ..... 4-15  
Document storage ..... 4-41  
Drive chain, cleaning and lubricating ... 7-28  
Drive chain slack ..... 7-27
- E**  
Engine break-in ..... 6-1  
Engine idling speed, checking ..... 7-19  
Engine oil and oil filter cartridge ..... 7-14  
Engine overheating ..... 7-40  
Engine serial number ..... 10-1  
EXUP system ..... 4-48
- F**  
Front and rear brake pads, checking ... 7-25  
Front fork, adjusting ..... 4-42  
Front fork, checking ..... 7-32  
Fuel ..... 4-35  
Fuel consumption, tips for reducing ..... 6-4  
Fuel level warning light ..... 4-6  
Fuel tank cap ..... 4-35  
Fuel tank overflow hose ..... 4-37  
Fuses, replacing ..... 7-35
- G**  
Glossary ..... 3-5
- H**  
Handlebar switches ..... 4-3  
Hazard switch ..... 4-4  
High beam indicator light ..... 4-6  
Horn switch ..... 4-4
- I**  
Identification numbers ..... 10-1  
Ignition circuit cut-off system ..... 4-50  
Immobilizer system ..... 4-1  
Immobilizer system indicator light ..... 4-7  
Indicator lights and warning lights ..... 4-5
- M**  
Main switch/steering lock ..... 4-2  
Maintenance and lubrication, periodic ..... 7-5  
Maintenance, emission control system ..... 7-3  
Malfunction indicator light (MIL) ..... 4-6  
Matte color, caution ..... 8-1  
Model label ..... 10-1
- N**  
Neutral indicator light ..... 4-6
- O**  
Oil pressure and Coolant temperature warning light ..... 4-8
- P**  
Parking ..... 6-4  
Part locations ..... 2-1  
Pass/LAP switch ..... 4-4
- R**  
Rear view mirrors ..... 4-41
- S**  
Safety information ..... 1-1  
Seat cover ..... 4-40  
Seats ..... 4-38  
Shift indicator light ..... 4-7  
Shifting ..... 6-3  
Shift pedal ..... 4-32  
Shock absorber assembly, adjusting ..... 4-45  
Sidestand ..... 4-49  
Sidestand, checking and lubricating ..... 7-31  
Spark plugs, checking ..... 7-12  
Special features ..... 3-1  
Specifications ..... 9-1  
Stability control indicator light ..... 4-8  
Starting the engine ..... 6-2

Steering, checking.....	7-32
Stop/Run/Start switch.....	4-4
Storage.....	8-4
Supporting the motorcycle.....	7-38
Swingarm pivots, lubricating.....	7-31

## T

Throttle grip, checking and lubricating.....	7-29
Tires.....	7-19
Titanium muffler, cleaning.....	8-3
Tool kit.....	7-2
Troubleshooting.....	7-38
Troubleshooting chart.....	7-39
Turn signal indicator lights.....	4-6
Turn signal switch.....	4-4

## V

Valve clearance.....	7-19
Vehicle identification number.....	10-1
Vehicle lights.....	7-37

## W

Wheel bearings, checking.....	7-33
Wheels.....	7-22

## Y

Yamalube.....	7-17
YRC functions visual guide.....	3-6
YRC settings.....	4-16
YRC (Yamaha Ride Control).....	3-1





