



⚠ READ THIS MANUAL CAREFULLY!
It contains important safety information.

OWNER'S MANUAL

WOLVERINE
R-SPEC

YXE70WPXH
YXE70WPHH
YXE70WPAH

2MB-F8199-7B



Read this manual carefully before operating this vehicle. This manual should stay with this vehicle if it is sold.

EC Declaration of Conformity

conforming to Directive 2006/42/EC

We, **YAMAHA MOTOR CO., LTD.** 2500 Shingai, Iwata, Japan,
declare in sole responsibility, that the product

YXE700E (YXE70WPXH) (5Y4AM92W0F0500461-)
(YXE70WPAH) (5Y4AM92W0F0500461-)

(Make, model)

to which this declaration applies, conforms to the essential health
and safety requirements of Directive 2006/42/EC

(If applicable)

and to the other relevant Directives of EEC

2014/30/EU

(Title and/or number and date of issue of the other Directives of EEC)

(If applicable)

To effect correct application of the essential health and safety requirements
stated in the Directives of EEC, the following-standards and/or technical
specifications were consulted:

ANSI ROHVA 1 - 2011

(Title and/or number and date of issue of standards and/or specifications)

Manufacturer

YAMAHA MOTOR MANUFACTURING CORPORATION OF AMERICA
1000 GA Highway 34 East, Newnan, Georgia 30265-1320, U.S.A.

Authorized Representative

YAMAHA MOTOR EUROPE N.V.
Koolhovenlaan 101, 1119 NC Schiphol-Rijk, The Netherlands

Signature

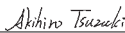
Akihiro Tsuzuki

General Manager
Engineering Division
Recreational Vehicle Business Unit
Vehicle & Solution Business Operations
YAMAHA MOTOR CO., LTD.

Date of Issue

05 February, 2016

INTRODUCTION

Congratulations on your purchase of the Yamaha YXE70WPXH / YXE70WPHH / YXE70WPAH. It represents the result of many years of Yamaha experience in the production of fine sporting, touring, and pace-setting racing vehicles. With the purchase of this Yamaha, you can now appreciate the high degree of craftsmanship and reliability that have made Yamaha a leader in these fields.

This manual will provide you with a good basic understanding of the features and operation of this vehicle. It also includes basic maintenance and inspection procedures. If you have any questions regarding the operation or maintenance of your vehicle, please consult a Yamaha dealer.

EWB03490





Please read this manual carefully before operating this vehicle. Do not attempt to operate this vehicle until you have attained adequate knowledge of its controls and operating features. Regular inspections and careful maintenance, along with good operating techniques, will help ensure that you safely enjoy the capabilities and reliability of this vehicle.

IMPORTANT MANUAL INFORMATION

FAILURE TO FOLLOW THE WARNINGS CONTAINED IN THIS MANUAL CAN RESULT IN SERIOUS INJURY OR DEATH.

Particularly important information is distinguished in this manual by the following notations:

	This is the safety alert symbol. It is used to alert you to potential personal injury hazards. Obey all safety messages that follow this symbol to avoid possible injury or death.
	A WARNING indicates a hazardous situation which, if not avoided, could result in death or serious injury.
	A NOTICE indicates special precautions that must be taken to avoid damage to the vehicle or other property.
TIP	A TIP provides key information to make procedures easier or clearer.

* Product and specifications are subject to change without notice.

IMPORTANT NOTE ABOUT USE

- **This vehicle is designed and manufactured for use on UNPAVED surfaces only. It is unsafe to operate this vehicle on any paved surface, paved street, paved road or motorway.**
- **Check the laws and regulations in force before choosing where to operate this vehicle. It is illegal to operate this vehicle on public lands where vehicles its size are prohibited.**

YXE70WPXH / YXE70WPHH / YXE70WPAH

OWNER'S MANUAL

©2016 by Yamaha Motor Co., Ltd.

1st edition, February 2016

All rights reserved.

Any reprinting or unauthorized use

without the written permission of

Yamaha Motor Co., Ltd.

is expressly prohibited.

Printed in U.S.A.

CONTENTS

LOCATION OF THE WARNING AND SPECIFICATION LABELS	1-1	Parking brake lever	4-13
SAFETY INFORMATION	2-1	Drive select lever	4-14
DESCRIPTION.....	3-1	Fuel tank cap.....	4-15
Left view	3-1	Doors.....	4-15
Right view.....	3-2	Seats	4-15
Controls and instruments.....	3-3	Adjusting the driver seat position.....	4-16
INSTRUMENT AND CONTROL FUNCTIONS.....	4-1	Seat belts	4-17
Main switch	4-1	Glove compartment	4-18
Indicator lights and warning lights	4-2	Storage compartments	4-19
Multi-function meter unit	4-6	Cup holders.....	4-20
Light switch	4-11	Cargo bed	4-21
On-Command drive knob		Adjusting the front shock absorber	
“2WD/4WD/DIFF LOCK”	4-12	assemblies	4-23
Horn switch	4-12	Adjusting the rear shock absorber	
Accelerator pedal	4-13	assemblies	4-28
Brake pedal	4-13	Trailer hitch bracket and receiver.....	4-33
		Auxiliary DC jack	4-33
		FOR YOUR SAFETY –	
		PRE-OPERATION CHECKS.....	5-1
		Front and rear brakes.....	5-3
		Fuel.....	5-3
		Engine oil.....	5-5

Coolant.....	5-6
Final gear.....	5-6
Differential gear	5-6
Accelerator pedal	5-6
Seat belts	5-6
Passenger handhold	5-7
Steering	5-7
Fittings and fasteners.....	5-7
Instruments, lights and switches.....	5-7
Control cables	5-8
Tires.....	5-8

OPERATION	6-1
Engine break-in	6-1
Starting the engine	6-2
Drive select lever operation and reverse driving	6-3
On-Command drive knob.....	6-5
Parking	6-7
Loading.....	6-7

BASIC GUIDE FOR SAFE USE	7-1
KNOW YOUR VEHICLE.....	7-1

LEARNING TO OPERATE YOUR VEHICLE	7-12
---	------

PERIODIC MAINTENANCE AND ADJUSTMENT	8-1
Owner's manual and tool kit.....	8-2
Periodic maintenance chart for the emission control system	8-4
General maintenance and lubrication chart.....	8-6
Hood	8-10
Panels	8-11
Engine oil and oil filter cartridge	8-14
Final gear oil	8-20
Differential gear oil	8-22
Coolant	8-24
Axle boots.....	8-29
Spark plug inspection.....	8-30
Cleaning the air filter element	8-32
Cleaning the air filter case/air duct check hose.....	8-36
V-belt case drain plug.....	8-36
Cleaning the spark arrester	8-37

Valve clearance	8-38	Headlight beam adjustment	8-57
Brakes	8-38	Tail/brake light bulb replacement	8-57
Checking the front and rear brake pads.....	8-39	Troubleshooting.....	8-58
Checking the brake fluid level	8-39	Troubleshooting charts.....	8-59
Brake fluid replacement	8-41	CLEANING AND STORAGE	9-1
Checking the brake pedal	8-41	Cleaning.....	9-1
Parking brake	8-42	Storage	9-2
Brake light switch adjustment.....	8-42	SPECIFICATIONS.....	10-1
Cable inspection and lubrication.....	8-42	CONSUMER INFORMATION	11-1
Brake pedal and accelerator pedal lubrication.....	8-43	Identification number records.....	11-1
Checking the stabilizer bushes	8-43	INDEX	12-1
Rear knuckle upper and lower pivot lubrication (left and right).....	8-44		
Steering shaft lubrication	8-44		
Wheel removal.....	8-45		
Tire replacement	8-45		
Wheel installation	8-46		
Battery.....	8-47		
Jump-starting.....	8-50		
Fuse replacement.....	8-52		
Replacing a headlight bulb.....	8-54		

LOCATION OF THE WARNING AND SPECIFICATION LABELS

Read and understand all of the labels on your vehicle. They contain important information for safe and proper operation of your vehicle.

Never remove any labels from your vehicle. If a label becomes difficult to read or comes off, a replacement label is available from your Yamaha dealer.

For Europe

1

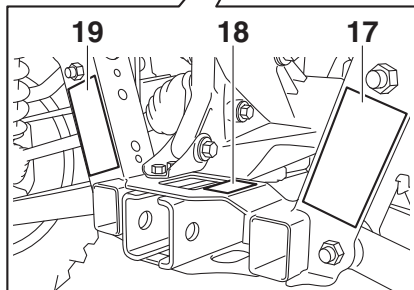
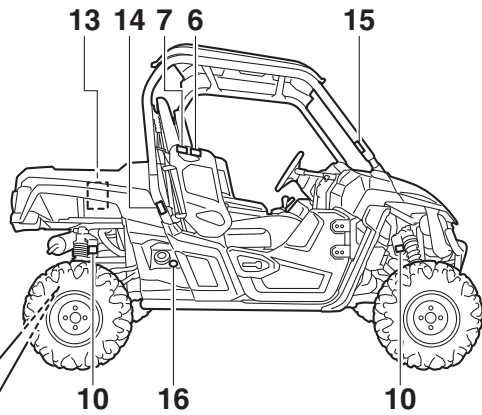
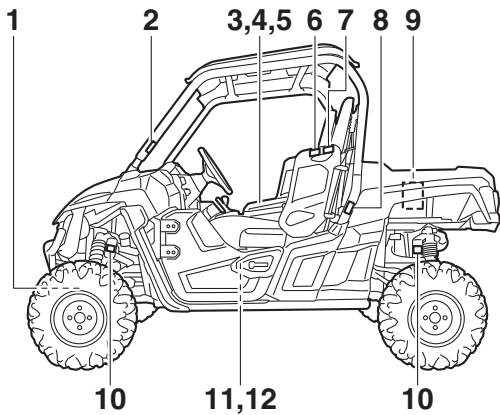

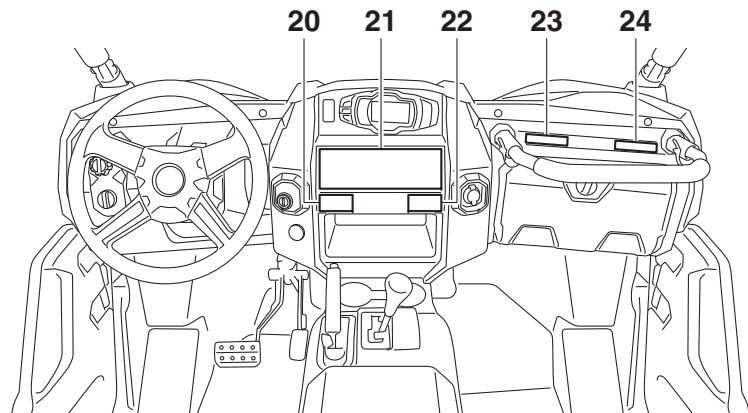

1

1

CE 2016

YAMAHA MOTOR CO.,LTD.
2500 SHINGAI,IWATA,,JAPAN

YXE700E

35.0 kW

595 kg

2MB-F155A-20

2

WARNING

Any part of your body (arms, legs, or head) outside of the vehicle can be crushed by the cage/frame.

If you think or feel that the vehicle may tip or roll, brace your feet on the floor or footrests, and keep your hands on the steering wheel or handhold. Never hold cage.

Do not try to stop a vehicle tipover using your arm or leg.

YAMAHA

1XD-K7761-00

3

⚠ AVERTISSEMENT

- Les vapeurs d'essence peuvent provoquer un incendie ou une explosion.
Afin d'éviter tout risque de blessure corporelle, voire mortelle, ne jamais stocker de carburant ni de liquide inflammable dans ce compartiment de rangement.
- La charge ne doit pas excéder 6.4 kg (13.5 lbs).

2MB-F151F-10

4

⚠ WARNING

- Fuel vapors can be a fire or explosion hazard.
To avoid injury or death, never store fuel or flammable liquids in this storage compartment.
- Storage should not exceed 13.5 lbs (6.4 kg)

2MB-F151F-00

5

⚠ AVERTISSEMENT

L'utilisation négligente d'un véhicule hors route peut causer de graves blessures, voire la mort.

Être préparé

- Attacher la ceinture de sécurité.
- Porter un casque homologué, une protection pour les yeux et une tenue de protection.
- Le conducteur doit pouvoir rejoindre aisément toutes les commandes alors qu'il est en position assise, son dos contre le dossier du siège.
- Les occupants doivent pouvoir rejoindre la poignée de maintien centrale alors que leurs pieds reposent à plat sur le plancher et qu'ils sont assis le dos contre le dossier du siège.
- Demeurer entièrement dans l'habitacle du véhicule.



Conduire de façon responsable

Prévenir la perte de contrôle ou les roulades :

- Éviter les manœuvres subites, glissements latéraux, dérapages, queues de poisson et zigzags; ne jamais tenter d'acrobaties.
- Ralentir avant d'entamer un virage.
- Éviter d'accélérer brusquement dans les virages, même à partir de l'arrêt.
- Être prêt pour pentes, terrains inhospitaliers, ornières, aspérités du terrain et autres facteurs réduisant la traction. Éviter les surfaces asphaltées.
- Ne pas conduire sur le flanc des pentes.
- Ne permettre à personne de prendre place dans la caisse de chargement.



Les roulades ont déjà causé des blessures graves et la mort, même sur terrain plat et sans obstacles.

Être prévoyant, être prêt

Si une roulade ou un capotage semble imminent, réduire le risque de blessures :

- Agripper fermement le volant ou la poignée de maintien et se préparer à encaisser le choc.
- Ne mettre aucune partie du corps hors du véhicule, pour quelque raison que ce soit.

Utilisation vigilante du véhicule

Faire sa part pour prévenir les blessures :

- Ne pas permettre la conduite acrobatique ou imprudente.
- S'assurer que le conducteur est âgé d'au moins 16 ans et qu'il est titulaire d'un permis de conduire valide.
- Ne permettre à personne de conduire le véhicule ou d'y prendre place après avoir consommé alcool ou drogues.
- Ne pas permettre la conduite du véhicule sur les chemins publics (à moins que les véhicules hors route y soient autorisés) – les collisions avec voitures et camions arrivent en un clin d'œil.
- Ne pas dépasser le nombre de places disponibles : 1 passager.

Lire le Manuel du propriétaire.

Lire le Guide de conseils à l'intention du conducteur du véhicule récréatif hors route.

Suivre toutes les directives et tous les avertissements.



YAMAHA

2MB-F1568-10

1

6

⚠ WARNING

Do not rest hands or arms on door or shoulder bolster.

To avoid Injury, keep hands and arms completely

Inside the vehicle by holding the steering wheel or handhold.

YAMAHA

1XD-K8483-00

7

⚠ AVERTISSEMENT

Ne pas appuyer les mains ni les bras sur la portière ou sur le coussin de l'épaule. Afin de prévenir les blessures, garder mains et bras dans l'habitacle et agripper le volant ou la poignée de maintien.

YAMAHA

1XD-K8483-10

8

⚠ AVERTISSEMENT

Toute partie du corps (bras, jambes, tête) se trouvant hors de l'habitacle risque d'être écrasée par l'arceau de protection.

Si une roulade ou un capotage semble imminent, caler les pieds sur le plancher ou sur les repose-pieds et agripper le volant ou la poignée de maintien. Ne jamais agripper l'arceau de protection.

Ne jamais tenter d'empêcher un capotage à l'aide du bras ou de la jambe.

YAMAHA

1XD-K7761-10

⚠ WARNING

Improper use of cargo bed or cage/frame can result in severe injury or death from loss of control, overturn or other accidents.

Never carry passengers in cargo bed.



Maximum Load in Cargo Bed: 300 lbs (136 kg)
Maximum Vehicle Load: 721 lbs (327 kg)

- Load or trailer may affect handling and stability.
 - Do not exceed the maximum load ratings for the cargo bed, trailer tongue, or vehicle.
 - Secure cargo so that it will not shift - a loose load could change handling unexpectedly or be thrown forward and strike occupants.
 - Keep weight in the cargo bed centered side to side and as low as possible. Top-heavy loads increase the risk of a rollover.
 - Do not tow or pull objects from any point other than the trailer hitch bracket or winch (if installed).
- When loaded with cargo or towing a trailer:
 - Reduce speed and allow more room to stop.
 - Turn gradually and slowly.
 - Avoid hills and rough terrain.
- Read Owner's Manual before loading, towing, or pulling objects.



11

WARNING

- Improper tire pressure or overloading this vehicle may cause severe injury or death from loss of control or rollover.
- Never set or allow tire pressure to be below the minimum. Tire may dislodge from rim.

OPERATING TIRE PRESSURE: With tires cold, set as follows.

- **VEHICLE LOAD** of 0 kg (0 lb) ~ 327 kg (721 lbs)
 Recommended: FRONT: 75 kPa (11 psi)
 REAR: 75 kPa (11 psi)
 Minimum: FRONT: 70 kPa (10 psi)
 REAR: 70 kPa (10 psi)

* Vehicle load is weight of operator, passengers, accessories, cargo, and (if applicable) trailer tongue weight. Do not exceed maximum vehicle load.

Gross Vehicle Weight Rating: 975 kg (2150 lbs) maximum including vehicle, weight of operator, passengers, accessories, cargo, and (if applicable) trailer tongue weight.

YAMAHA

2MB-F1696-10

12

AVERTISSEMENT

- Une pression de gonflage incorrecte des pneus ou la surcharge du véhicule risquent de provoquer une perte de contrôle ou un capotage, entraînant des blessures, voire la mort.
- Ne jamais régler la pression de gonflage ni la laisser baisser sous le seuil minimal; le pneu risque de se déjancer.

PRESSION DE SERVICE DES PNEUS : Régler les pneus à froid.

- **CHARGE DU VÉHICULE** : de 0 kg (0 lbs) à 327 kg (721 lbs)
 Recommandation: AVANT: 75 kPa (11 psi)
 ARRIÈRE: 75 kPa (11 psi)
 Minimum: AVANT: 70 kPa (10 psi)
 ARRIÈRE: 70 kPa (10 psi)

* La charge du véhicule comprend le poids du conducteur, du passager, des accessoires, de l'équipement et (le cas échéant) du timon. Ne pas dépasser la charge maximale du véhicule.

Poids nominal brut du véhicule (PNBV) : 975 kg (2150 lbs) maximum, y compris le poids du véhicule, du conducteur, du passager, des accessoires, de l'équipement, et (le cas échéant) du timon.

YAMAHA

2MB-F1696-20

13

⚠ AVERTISSEMENT

Aucun passager
dans la caisse de
chargement



Le mauvais usage de la caisse de chargement ou de l'arceau de protection peut provoquer de graves blessures ou la mort par suite d'une perte de contrôle, d'un capotage ou d'un accident quelconque.

Charge maximale dans la caisse : 136 kg (300 lbs)
Charge maximale du véhicule : 327 kg (721 lbs)

Une charge ou une remorque peut nuire à la maniabilité et à l'équilibre du véhicule.

- Ne pas dépasser la limite de charge nominale pour la caisse de chargement, le timon et le véhicule.
- Arrimer solidement toute charge – un article mal arrimé pourrait nuire soudainement à la maniabilité ou être projeté vers l'avant et heurter un occupant.
- Répartir le poids de la charge de façon équilibrée et le plus bas possible dans la caisse; une charge mal équilibrée augmente le risque de capotage.
- Ne tirer ni ne remorquer aucun objet d'un point autre que la fixation du timon ou le treuil (le cas échéant).

Lors du transport d'une charge ou lors du remorquage :

- Réduire la vitesse et prévoir une distance de freinage accrue.
- Négocier les virages progressivement et lentement.
- Éviter les pentes et les terrains accidentés.

Lire le Manuel du propriétaire avant de charger le véhicule, de tirer ou de remorquer une charge.

YAMAHA

2MB-F4897-10

14

⚠ AVERTISSEMENT



Toute partie du corps (bras, jambes, tête) se trouvant hors de l'habitacle risque d'être écrasée par l'arceau de protection.

Si une roulade ou un capotage semble imminent, caler les pieds sur le plancher ou sur les repose-pieds et agripper le volant ou la poignée de maintien. Ne jamais agripper l'arceau de protection.

Ne jamais tenter d'empêcher un capotage à l'aide du bras ou de la jambe.

YAMAHA

1XD-K7762-10

15

⚠ WARNING



Any part of your body (arms, legs, or head) outside of the vehicle can be crushed by the cage/frame.

If you think or feel that the vehicle may tip or roll, brace your feet on the floor or footrests, and keep your hands on the steering wheel or handhold. Never hold cage.

Do not try to stop a vehicle tipover using your arm or leg.

YAMAHA

1XD-K7762-00

1

16



1

17

⚠ AVERTISSEMENT

Le chargement ou le tirage incorrects d'une remorque ou d'un objet peut modifier la maniabilité et l'équilibre, et risque de provoquer un capotage ou autre accident.

- Attacher solidement le chargement afin de l'immobiliser.
- Ne jamais dépasser le poids en flèche de 490 N(50 kgf)/110 lbf du dispositif d'attelage.
- Ne pas remorquer une charge totale de plus de 6664 N(680 kgf)/1500 lbf (remorque plus chargement).
- N'attacher charge ou remorque qu'au support de fixation d'attelage.
- Lire le manuel du propriétaire avant de charger le véhicule et de remorquer ou tirer une charge.

YAMAHA

1XD-F151K-10

18

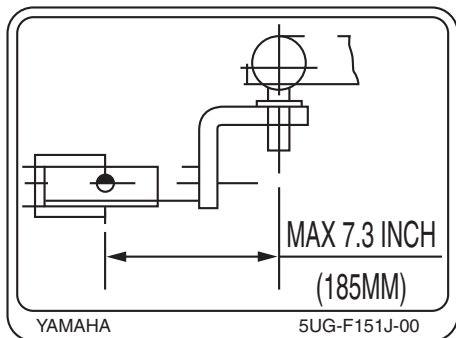

19

⚠ WARNING

Improperly loading a trailer or pulling an object can affect handling, stability, and risk of overturn or other accidents.

- Secure load to prevent it from shifting.
- Never load more than 490 N (50 kgf)/110 lbf tongue weight on towing bracket.
- Do not tow more than 6664 N(680 kgf)/1500 lbf rolling weight (trailer plus cargo).
- Tow or pull only from hitch bracket.
- Read Owner's Manual before loading, towing, or pulling objects.

YAMAHA

1XD-F151K-00

1

Head to Toe Safety Checklist

- ✓ **Head** Helmet and eye protection.
- ✓ **Body** Seatbelt and protective clothing.
- ✓ **Hands** Inside vehicle and holding the handhold or steering wheel.
- ✓ **Feet** On floor or footrests, ready to brace, and door closed.

YAMAHA

TXD-F1568-00

WARNING

Improper Use of Off-Highway Vehicle Can Cause Severe Injury or Death

Be Prepared

- Fasten seat belts.
- Wear an approved helmet, eye protection and protective gear.
- Driver must be able to comfortably reach all controls while sitting upright with back against seat.
- Passenger must be able to reach the handhold while keeping feet flat on floor and sitting upright with back against seat.
- Stay completely inside the vehicle.

Drive Responsibly

- Avoid loss of control and rollovers:
- Avoid abrupt maneuvers, sideways sliding, skidding, or fishtailing, and never do donuts.
- Slow down before entering a turn.
- Avoid hard acceleration when turning, even from a stop.
- Plan for hills, rough terrain, ruts, and other changes in traction and terrain. Avoid paved surfaces.
- Avoid side hilling (riding across slopes).
- Do not allow anyone to ride in the cargo bed.



Rollovers have caused severe injuries and death, even on flat, open areas.

Pay Attention and Plan Ahead

- If you think or feel the vehicle may tip or roll, reduce your risk to injury:
- Keep a firm grip on the steering wheel or handhold and brace yourself.
 - Do not put any part of your body outside of the vehicle for any reason.

Require Proper Use of Your Vehicle

- Do your part to prevent injuries:
- Do not allow careless or reckless driving.
 - Make sure operators are 16 or older with valid driver's license.
 - Do not let people drive or ride after using alcohol or drugs.
 - Do not allow operation on public roads (unless designated for off-highway vehicle access) — collisions with cars and trucks can occur.
 - Do not exceed seating capacity: 1 passenger.



Read Owner's Manual
Read Tips Guide for the Recreational Off-Highway Vehicle Driver
Follow All Instruction and Warnings

YAMAHA

2MB-F1568-00

22

**Liste de vérification
de sécurité intégrale**

- ✓ **Tête** Casque et protection des yeux
- ✓ **Corps** Ceinture de sécurité et vêtements de protection
- ✓ **Mains** À l'intérieur du véhicule, tenant la poignée de maintien ou le volant.
- ✓ **Pieds** Sur le plancher ou les repose-pieds, prêts à encaisser le choc; portière fermée.

YAMAHA

1XD-F1558-10

23

Be Prepared

Adjust, lock and never remove handhold.

Always use handhold, Never hold cage.

Always wear seatbelt and helmet.

1XD-F8446-00

24

Toujours prévoir l'imprévu.

Régler et verrouiller la poignée de maintien; ne jamais la retirer.

Toujours agripper la poignée de maintien, non l'arceau de protection.

Toujours porter la ceinture de sécurité et un casque approprié.

1XD-F8446-10

For Oceania

1

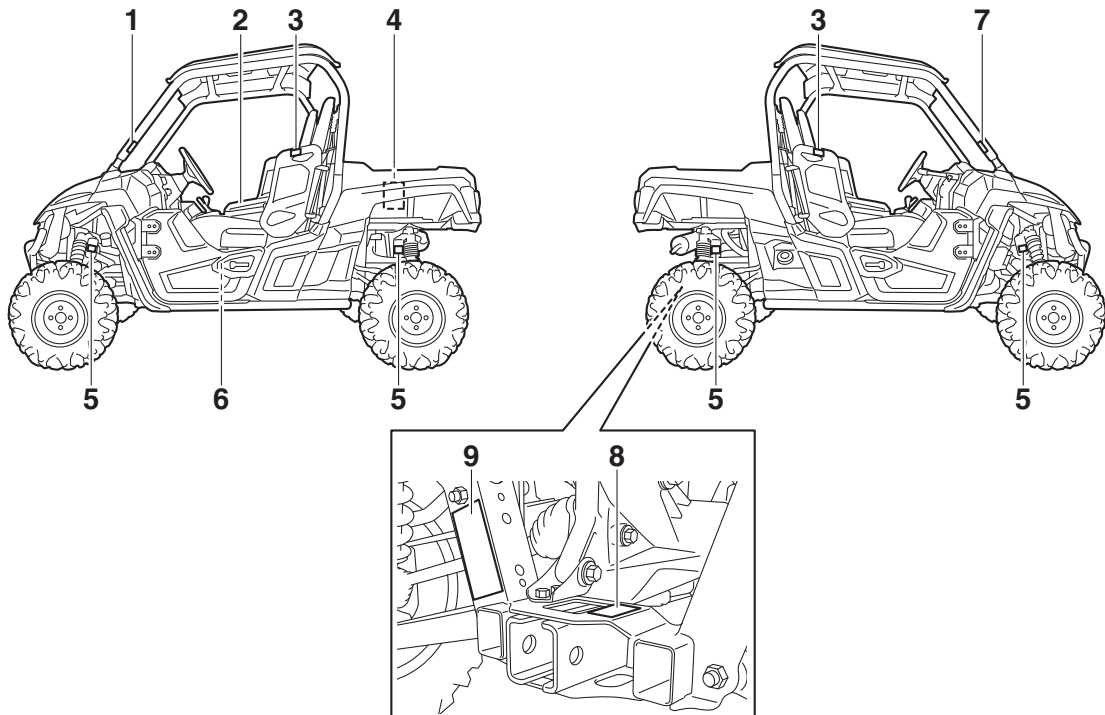

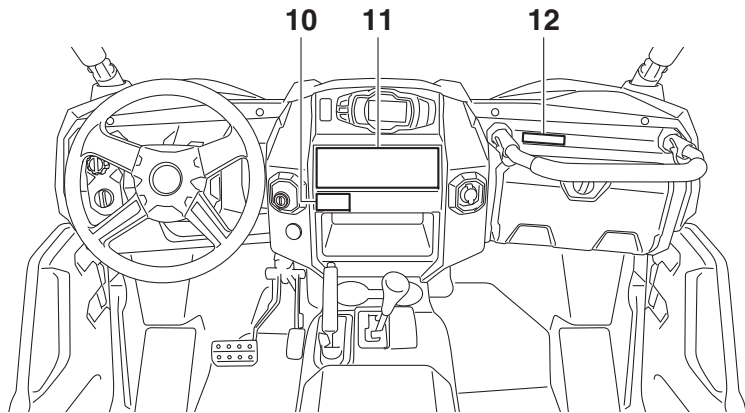

1

⚠ WARNING

Any part of your body (arms, legs, or head) outside of the vehicle can be crushed by the cage/frame.

If you think or feel that the vehicle may tip or roll, brace your feet on the floor or footrests, and keep your hands on the steering wheel or handhold. Never hold cage.

Do not try to stop a vehicle tipover using your arm or leg.

YAMAHA 1XD-K7761-00

2

⚠ WARNING

- Fuel vapors can be a fire or explosion hazard. To avoid injury or death, never store fuel or flammable liquids in this storage compartment.
- Storage should not exceed 13.5 lbs (6.4 kg)

2MB-F151F-00

3

⚠ WARNING

Do not rest hands or arms on door or shoulder bolster. To avoid Injury, keep hands and arms completely inside the vehicle by holding the steering wheel or handhold.

YAMAHA

1XD-K8483-00

4

⚠ WARNING

Improper use of cargo bed or cage/frame can result in severe injury or death from loss of control, overturn or other accidents.

Never carry passengers in cargo bed.



Maximum Load in Cargo Bed: 300 lbs (136 kg)
Maximum Vehicle Load: 721 lbs (327 kg)

- Load or trailer may affect handling and stability.
 - Do not exceed the maximum load ratings for the cargo bed , trailer tongue, or vehicle.
 - Secure cargo so that it will not shift - a loose load could change handling unexpectedly or be thrown forward and strike occupants.
 - Keep weight in the cargo bed centered side to side and as low as possible. Top-heavy loads increase the risk of a rollover.
 - Do not tow or pull objects from any point other than the trailer hitch bracket or winch (if installed).
- When loaded with cargo or towing a trailer:
 - Reduce speed and allow more room to stop.
 - Turn gradually and slowly.
 - Avoid hills and rough terrain.
- Read Owner's Manual before loading, towing, or pulling objects.

YAMAHA

2MB-F4897-00

5



1

6

WARNING

- Improper tire pressure or overloading this vehicle may cause severe injury or death from loss of control or rollover.
- Never set or allow tire pressure to be below the minimum. Tire may dislodge from rim.

OPERATING TIRE PRESSURE: With tires cold, set as follows.

- VEHICLE LOAD of 0 kg (0 lb) ~ 327 kg (721 lbs)
 Recommended: FRONT: 75 kPa (11 psi)
 REAR: 75 kPa (11 psi)
 Minimum: FRONT: 70 kPa (10 psi)
 REAR: 70 kPa (10 psi)

* Vehicle load is weight of operator, passengers, accessories, cargo, and (if applicable) trailer tongue weight. Do not exceed maximum vehicle load.

Gross Vehicle Weight Rating: 975 kg (2150 lbs) maximum including vehicle, weight of operator, passengers, accessories, cargo, and (if applicable) trailer tongue weight.

YAMAHA

2MB-F1696-10

7

WARNING



Any part of your body (arms, legs, or head) outside of the vehicle can be crushed by the cage/frame.

If you think or feel that the vehicle may tip or roll, brace your feet on the floor or footrests, and keep your hands on the steering wheel or handhold. Never hold cage.

Do not try to stop a vehicle tipover using your arm or leg.

YAMAHA

1XD-K7762-00

8

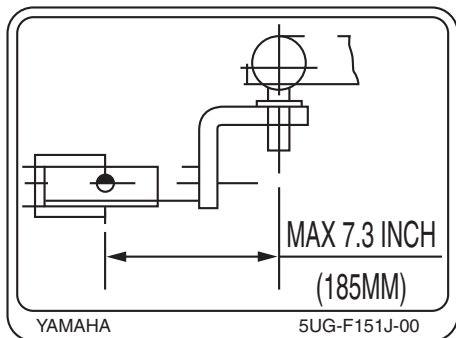

9

⚠ WARNING

Improperly loading a trailer or pulling an object can affect handling, stability, and risk of overturn or other accidents.

- Secure load to prevent it from shifting.
- Never load more than 490 N (50 kgf)/110 lbf tongue weight on towing bracket.
- Do not tow more than 6664 N(680 kgf)/1500 lbf rolling weight (trailer plus cargo).
- Tow or pull only from hitch bracket.
- Read Owner's Manual before loading, towing, or pulling objects.

YAMAHA

1XD-F151K-00

1

10

Head to Toe Safety Checklist

- ✓ **Head** Helmet and eye protection.
- ✓ **Body** Seatbelt and protective clothing.
- ✓ **Hands** Inside vehicle and holding the handhold or steering wheel.
- ✓ **Feet** On floor or footrests, ready to brace, and door closed.

YAMAHA

1XD-F1558-00

11

⚠ WARNING

Improper Use of Off-Highway Vehicle Can Cause Severe Injury or Death

Be Prepared

- Fasten seat belts.
- Wear an approved helmet, eye protection and protective gear.
- Driver must be able to comfortably reach all controls while sitting upright with back against seat.
- Passenger must be able to reach the handhold while keeping feet flat on floor and sitting upright with back against seat.
- Stay completely inside the vehicle.

Drive Responsibly

- Avoid loss of control and rollovers:
 - Avoid abrupt maneuvers, sideways sliding, skidding, or fishtailing, and never do donuts.
 - Slow down before entering a turn.
 - Avoid hard acceleration when turning, even from a stop.
 - Plan for hills, rough terrain, ruts, and other changes in traction and terrain. Avoid paved surfaces.
 - Avoid side hilling (riding across slopes).
 - Do not allow anyone to ride in the cargo bed.



Rollovers have caused severe injuries and death, even on flat, open areas.

Pay Attention and Plan Ahead

- If you think or feel the vehicle may tip or roll, reduce your risk to injury:
- Keep a firm grip on the steering wheel or handhold and brace yourself.
 - Do not put any part of your body outside of the vehicle for any reason.

Require Proper Use of Your Vehicle

- Do your part to prevent injuries:
- Do not allow careless or reckless driving.
 - Make sure operators are 16 or older with valid driver's license.
 - Do not let people drive or ride after using alcohol or drugs.
 - Do not allow operation on public roads (unless designated for off-highway vehicle access) — collisions with cars and trucks can occur.
 - Do not exceed seating capacity: 1 passenger.



Read Owner's Manual
Read Tips Guide for the Recreational Off-Highway Vehicle Driver
Follow All Instruction and Warnings

YAMAHA

2MB-F1568-00

12

Be Prepared
Adjust, lock and never remove handhold.
Always use handhold, Never hold cage.
Always wear seatbelt and helmet.

1XD-F8446-00



SAFETY INFORMATION

Be a responsible owner

As the vehicle's owner, you are responsible for the safe and proper operation of your Yamaha Wolverine. While understanding all parts of this manual are important for vehicle ownership, be sure to read this chapter and the instructions in Chapter 7 before operating your Yamaha Wolverine. Also use these two chapters and the labels on the vehicle to instruct new operators and passengers. Do not allow anyone else to operate your vehicle or ride as a passenger if you are unsure that he/she is willing and able to follow these instructions.

Get to know your vehicle

This off-road vehicle will handle and maneuver differently from cars, ATVs, go-carts, golf-cars and grounds-keeping vehicles. Follow these instructions to reduce your risk of an accident and to reduce the risk of serious injury or death in the event of an accident.

Before you operate your Yamaha Wolverine

- Prepare yourself and your passenger:

- This vehicle is intended for use only by an operator 16 or older with a valid motor vehicle license. Check country laws for minimum age requirements.



- This vehicle is designed to carry the driver and one passenger. Never carry passengers in the cargo bed.
- Both driver and passenger should wear seat belts properly.
- Both driver and passenger must be able to put both feet flat on the floorboard while seated upright with their backs against the backrests. Passenger must be able to reach and hold the passenger handhold within the cage/frame.
- Both driver and passenger should wear an approved motorcycle helmet that fits properly. Both driver and passenger should also wear eye protection (goggles or a face shield), gloves, over-the-ankle boots, long-sleeved shirt or jacket, and long pants.

- Do not drive or ride as passenger after using drugs or alcohol.

Prepare your vehicle

Perform the pre-operation checks each time you use the vehicle to make sure it is in safe operating condition. Failure to inspect or maintain the vehicle properly increases the possibility of an accident or equipment damage. See page 5-1 for a list of pre-operation checks.

Prepare your load or trailer

Carrying loads, towing a trailer, or pulling objects can affect handling, stability, and cause the risk of overturns or other accidents.

- Read Chapter 6 before loading, towing, or pulling objects.
- Do not overload the vehicle or trailer. Refer to label in cargo bed for cargo bed load limit. Refer to label next to hitch for tongue weight and trailer load limits.
- Keep weight in the cargo bed centered side to side, and as low and as far forward as possible.
- Secure cargo so that it will not shift – a loose load could change handling unexpectedly or be thrown forward and strike occupants.

While using your Yamaha Wolverine

- Keep your body completely inside the vehicle at all times. Keep both hands on the steering wheel. Be sure the passenger is seated, belted, and holding onto the passenger handhold. Close doors before driving. Any part of your body (arms, legs, and head) outside the vehicle can be struck by objects your vehicle is passing or crushed by the vehicle cage/frame in a roll-over accident.
- Watch for branches, brush, or other hazards that could enter the vehicle.

- Abrupt maneuvers or aggressive driving, even on flat, open areas, can cause loss of control, including rollovers. The Wolverine has higher ground clearance and other features to handle rugged terrain, and, as a result, can overturn in situations where some other vehicles may not.
- Avoid rollovers:
 - Use care when turning:
 - Turning the steering wheel too far or too fast can result in a rollover.
 - Avoid sideways sliding, skidding, or back-wheel sliding, and never do donuts.
 - Slow down before entering a turn and avoid hard braking in a turn.
 - When making tight turns from a stop or at slow speeds, avoid sudden or hard acceleration.

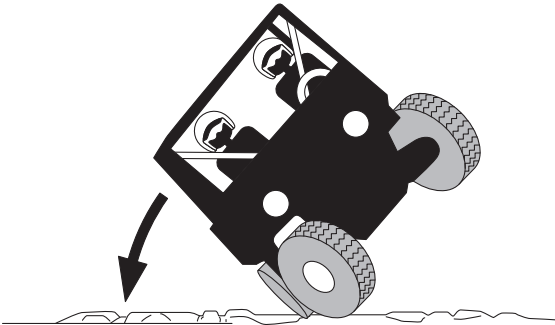

- Drive straight up and down inclines, not across them. If crossing a hill is unavoidable, drive slowly and turn downhill immediately if you feel the vehicle may tip.
- Avoid paved surfaces. Turn gradually and go slowly if you must drive on pavement. This vehicle is designed for off-road use only.

- If you think or feel that the vehicle may tip or roll, keep your body completely inside the protective structure of the vehicle:
 - Brace yourself by pressing your feet firmly on the floorboard and keep a firm grip on the steering wheel or passenger handhold.
 - Do not put your hands or feet outside of the vehicle for any reason. Your arm or leg could be crushed.
 - Do not try to stop a vehicle tipover using your arm or leg.
- Do not operate this vehicle on any public street, road, or highway, even if dirt or gravel.
- Do not operate the vehicle in fast-flowing water or water deeper than 37 cm (15 in). If you must cross shallow, slow-moving water, choose your path carefully to avoid sharp drop-offs, large rocks, or slippery surfaces. Operating this vehicle through deep or fast-flowing water can lead to loss of control or overturn. To reduce your risk of drowning or other injuries, use care when crossing through water.
- When loaded with cargo or towing a trailer:
 - Reduce speed, operate in low gear only, and allow more room to stop.
 - Avoid hills and rough terrain. Use extreme caution when towing or carrying a load on inclines.
 - Load trailer properly and use extra care when towing or pulling.
- Do not tow or pull objects from any part of the vehicle other than the trailer hitch bracket or winch (if installed).

Avoid carbon monoxide poisoning

All engine exhaust contains carbon monoxide, a deadly gas. Breathing carbon monoxide can cause headaches, dizziness, drowsiness, nausea, confusion, and eventually death.

Carbon monoxide is a colorless, odorless, tasteless gas which may be present even if you do not see or smell any engine exhaust. Deadly levels of carbon monoxide can collect rapidly and you can quickly be overcome and unable to save yourself. Also, deadly levels of carbon monoxide can linger for hours or days in enclosed or poorly-ventilated areas. If you experience any symptoms of carbon monoxide poisoning, leave the area immediately, get fresh air, and **SEEK MEDICAL TREATMENT**.

- Do not run engine indoors. Even if you try to ventilate engine exhaust with fans or open windows and doors, carbon monoxide can rapidly reach dangerous levels.
- Do not run engine in poorly ventilated or partially enclosed areas such as barns, garages, or carports.
- Do not run engine outdoors where engine exhaust can be drawn into a building through openings such as windows and doors.

Genuine Yamaha Accessories

Choosing accessories for your Wolverine is an important decision. Genuine Yamaha Accessories, which are available only from a Yamaha dealer, have been designed, tested, and approved by Yamaha for use on your Wolverine.

Many companies with no connection to Yamaha manufacture parts and accessories or offer other modifications for Yamaha vehicles. Yamaha is not in a position to test the products that these aftermarket companies produce. Therefore, Yamaha can neither endorse nor recommend the use of accessories not sold by Yamaha or modifications not specifically recommended by Yamaha, even if sold and installed by a Yamaha dealer.

Aftermarket parts, accessories, and modifications

While you may find aftermarket products similar in design and quality to genuine Yamaha Accessories, recognize that some aftermarket accessories or modifications are not suitable because of potential safety hazards to you or others. Installing aftermarket products or having other modifications performed to your Wolverine that change any of the vehicle's design or operation characteristics can put you and others at greater risk of serious injury or death. You are responsible for injuries related to changes in the vehicle.

Aftermarket tires and rims

The tires and rims that came with your Wolverine were designed to match the performance capabilities and to provide the best combination of handling, braking, and comfort. Other tires, rims, sizes, and combinations may not be appropriate. Refer to page 8-45 for tire specifications and more information on replacing your tires.

DESCRIPTION

Left view

3

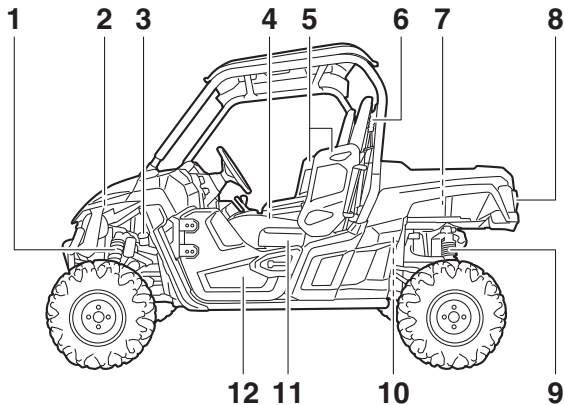

- 1. Front shock absorber assembly
- 2. Radiator cap
- 3. Brake fluid reservoir
- 4. Air filter
- 5. Shoulder bolster
- 6. Driver seat belt
- 7. Cargo bed
- 8. Tail/brake light
- 9. Rear shock absorber assembly
- 10. Spark plug

- 11. Driver seat
- 12. Door

Right view

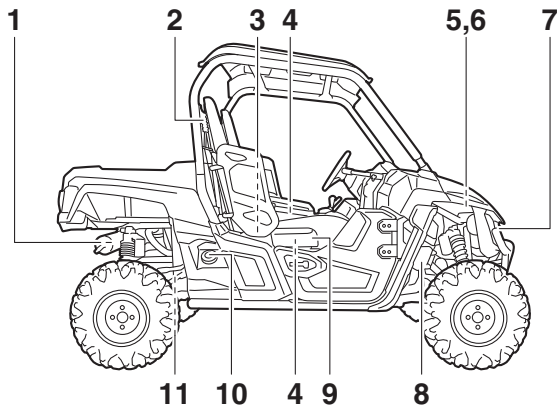

1. Spark arrester
2. Passenger seat belt
3. Engine oil dipstick
4. Storage compartment
5. Battery
6. Fuses
7. Headlight
8. Coolant reservoir
9. Passenger seat
10. Fuel tank cap
11. Oil filter cartridge

Controls and instruments

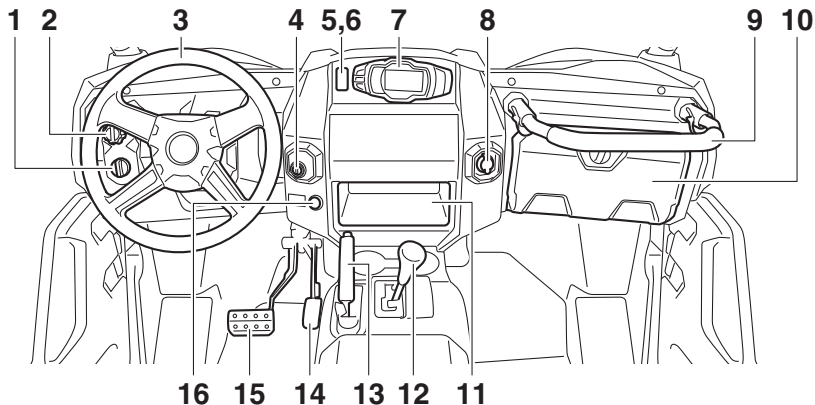

1. Light switch
2. On-Command drive knob
3. Steering wheel
4. Main switch
5. Helmet indicator light
6. Seat belt indicator light
7. Multi-function meter unit
8. Auxiliary DC jack

9. Passenger handhold
10. Glove compartment
11. Storage compartment
12. Drive select lever
13. Parking brake lever
14. Accelerator pedal
15. Brake pedal
16. Horn switch

The vehicle you have purchased may differ slightly from those shown in the figures of this manual.

INSTRUMENT AND CONTROL FUNCTIONS

Main switch

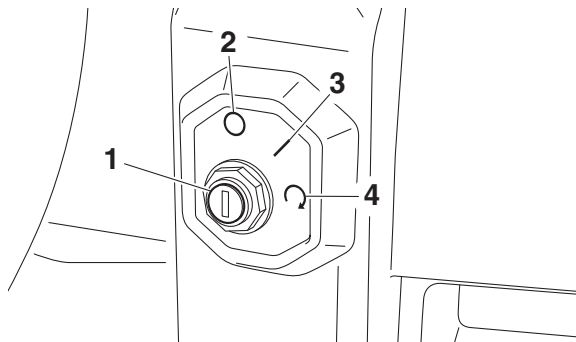

1. Main switch
2. “○” (off)
3. “I” (on)
4. “↻” (start)

Functions of the respective switch positions are as follows:

“ I ” (on):

All electrical circuits are supplied with power. The key cannot be removed.

TIP

The helmet indicator light comes on and stays on while the key is turned to “ I ” (on).

4

“○” (off):

All electrical circuits are switched off. The key can be removed.

“↻” (start):

The electric starter is engaged by turning and holding the key in this position. Release the key when the engine starts.

Indicator lights and warning lights

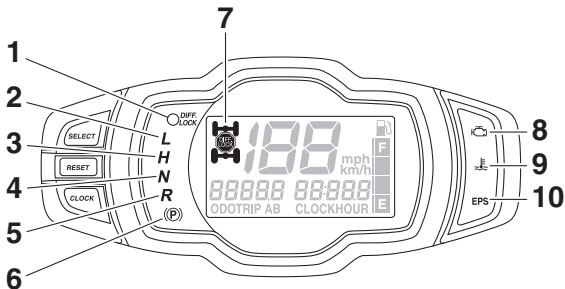

1. On-Command differential gear lock indicator light "DIFF. LOCK"
2. Low-range indicator light "L"
3. High-range indicator light "H"
4. Neutral indicator light "N"
5. Reverse indicator light "R"
6. Parking brake indicator light "(P)"
7. On-Command four-wheel-drive/differential gear lock indicator "4WD"/"4x4"
8. Engine trouble warning light "🔧"
9. Coolant temperature warning light "🌡️"
10. Electric Power Steering warning light "EPS"

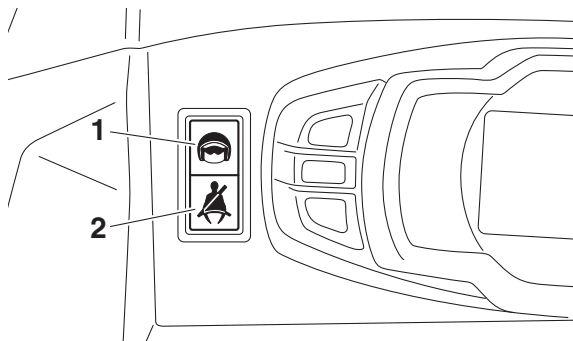

1. Helmet indicator light "📖"
2. Seat belt indicator light "🚰"

EBU31270

Low-range indicator light "L"

This indicator light comes on when the drive select lever is in the "L" position.

EBU31280

High-range indicator light "H"

This indicator light comes on when the drive select lever is in the "H" position.

EBU31290

Neutral indicator light “N”

This indicator light comes on when the drive select lever is in the “N” position.

EBU31300

Reverse indicator light “R”

This indicator light comes on when the drive select lever is in the “R” position.

EBU31310

Parking brake indicator light “(P)”

This indicator light comes on when the parking brake is applied.

EBU31320



On-Command four-wheel-drive indicator “ The On-Command four-wheel-drive indicator “ The On-Command differential gear lock indicator “TIP****

- Due to the synchronizing mechanism in the differential gear case, the four-wheel-drive indicator may not come on until the vehicle starts moving.
- When the On-Command drive knob “2WD/4WD/DIFF LOCK” is set to “DIFF LOCK” or “4WD”, the indicator “

4

Coolant temperature warning light “”

If the coolant temperature reaches a specific level, this light comes on to warn that the coolant temperature is too hot. If the light comes on during operation, stop the engine as soon as it is safe to do so and allow the engine to cool down for about 10 minutes. (See page 8-60.)

The electrical circuit of the warning light can be checked by turning the key to “” (on). If the warning light does not come on initially when the key is turned to “” (on), or if the warning light remains on, have a Yamaha dealer check the electrical circuit.



NOTICE

- **The engine may overheat if the vehicle is overloaded. If this happens, reduce the load to specification.**

- **After restarting, make sure that the warning light is out. Continuous use while this warning light is on may cause damage to the engine.**
-

Engine trouble warning light “”

This warning light comes on or flashes if a problem is detected in the electrical circuit monitoring the engine. When this occurs, have a Yamaha dealer check the self-diagnosis system. (See page 4-10 for an explanation of the self-diagnosis device.)

The electrical circuit of the warning light can be checked by turning the key to “” (on). If the warning light does not come on initially when the key is turned to “” (on), or if the warning light remains on, have a Yamaha dealer check the electrical circuit.

Electric Power Steering warning light “EPS”

This warning light comes on when the key is turned to “ I ” (on), and then goes off once the engine is started. If the warning light remains on or comes on after the engine is started, the EPS system may not be working correctly. When this occurs, have a Yamaha dealer check the EPS system.

The electrical circuit of the warning light can be checked by turning the key to “ I ” (on). If the warning light does not come on, have a Yamaha dealer check the electrical circuit.

TIP

If the steering load is too heavy (e.g., excessive steering use at slow speed or when operating in deep mud, sand, or snow), the power assist is reduced to protect the EPS motor from overheating.

Helmet indicator light “”

The indicator light comes on and stays on while the key is turned to “ I ” (on) to remind the occupants to always wear a helmet. If the indicator light does not come on when the key is turned to “ I ” (on), have a Yamaha dealer check the electrical circuit.

Seat belt indicator light “”

The indicator light comes on when the key is turned to “ I ” (on) to remind the occupants to fasten their seat belt. The indicator light stays on until the driver seat belt is properly latched. If the indicator light does not come on when the key is turned to “ I ” (on), or if the indicator light remains on after the driver seat belt is properly latched, have a Yamaha dealer check the electrical circuit.

Multi-function meter unit

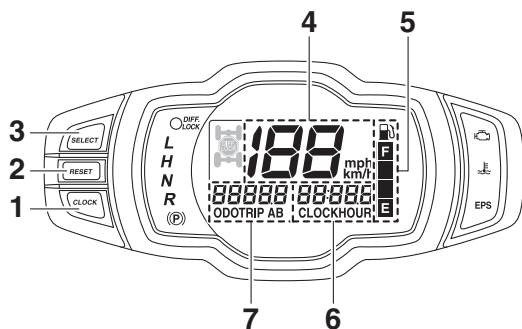

1. "CLOCK" button
2. "RESET" button
3. "SELECT" button
4. Speedometer
5. Fuel gauge
6. Clock/Hour meter/Voltage display
7. Odometer/Tripmeter A/Tripmeter B

The multi-function meter unit is equipped with the following:

- speedometer
- odometer
- two tripmeters
- clock

- hour meter
- voltage display
- fuel gauge
- error code display

Speedometer

The speedometer shows the vehicle's traveling speed. The speedometer can be set to "mph" or "km/h". This also changes the odometer and tripmeter units between miles and kilometers. To change the display between "mph" and "km/h", turn the key to "○" (off), then while holding the "SELECT" button pushed, turn the key to "⏻" (on).

Odometer and tripmeters

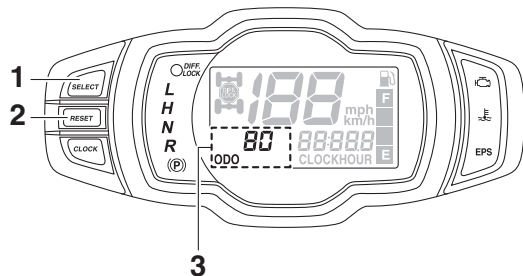

1. “SELECT” button
2. “RESET” button
3. Odometer/Tripmeter A/Tripmeter B

The odometer shows the total distance traveled by the vehicle. The odometer can be used for maintenance and service intervals.

The tripmeters show the distance traveled since they were last reset. The tripmeters can be used to record the distance traveled on a single trip, or to estimate the distance that can be traveled with a full tank of gas, etc.

Push the “SELECT” button to switch between the odometer “ODO” and the tripmeters “TRIP A” and “TRIP B” in the following order: ODO → TRIP A → TRIP B → ODO

To reset a tripmeter, set the display to the tripmeter you want to reset, then push the “RESET” button for three seconds.

TIP

- The odometer will lock at 99999.
- The tripmeters will reset and continue counting after 9999.9 is reached.

Clock, hour meter and voltage display

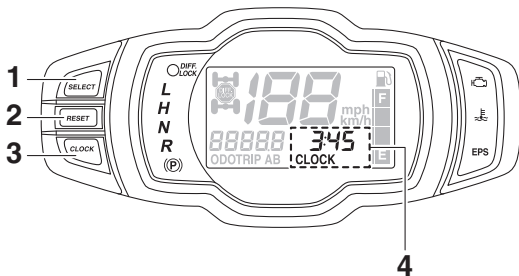

1. "SELECT" button
2. "RESET" button
3. "CLOCK" button
4. Clock/Hour meter/Voltage display

The clock displays time in 12-hour format.

The hour meter shows the total time the engine has been running.

The voltage display shows the battery voltage.

Push the "CLOCK" button to switch between the clock "CLOCK", the hour meter mode "HOUR" and the voltage display mode "۵۰۰۰" in the following order:

CLOCK → HOUR → ۵۰۰۰ → CLOCK

To set the clock

1. Set the display to the clock.
2. Push both the "SELECT" button and "RESET" button for three seconds. The hour digits will start flashing.
3. Push the "RESET" button to set the hours.
4. Push the "SELECT" button, and the minute digits will start flashing.
5. Push the "RESET" button to set the minutes.
6. Push the "SELECT" button and then release it to start the clock.

Voltage display

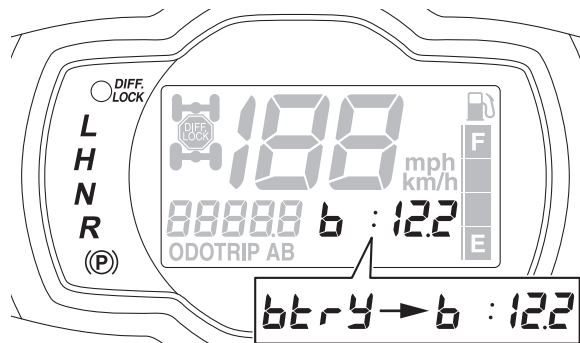

This display shows the battery voltage. “b t r y” appears for 1 second when the voltage display mode is first selected, and then “6 :” appears and the battery voltage is displayed.

If the battery voltage is less than 10 volts, “LO” is displayed, and if the voltage is above 16 volts, “HI” is displayed.

ECB02050

NOTICE

If the voltage display indicates “LO” or “HI”, there may be trouble with the battery charging circuit or the battery may be faulty. If this occurs, have a Yamaha dealer check or repair the vehicle.

4

Fuel gauge

The fuel gauge indicates the amount of fuel in the fuel tank. The display segments of the fuel gauge disappear from “F” (full) towards “E” (empty) as the fuel level decreases. When the “E” segment disappears and the fuel level warning indicator flashes, refuel as soon as possible.

TIP

The fuel gauge is equipped with a self-diagnosis system. If the fuel gauge electrical circuit is not working correctly, all display

segments and the fuel level warning indicator will flash repeatedly. If this occurs, have a Yamaha dealer check the vehicle.

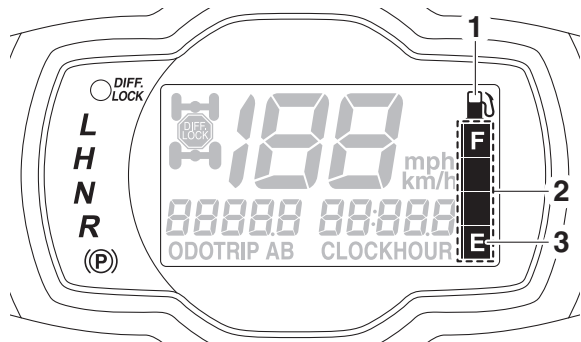

- 4
1. Fuel level warning indicator
 2. Fuel gauge
 3. "E" segment

Error code display

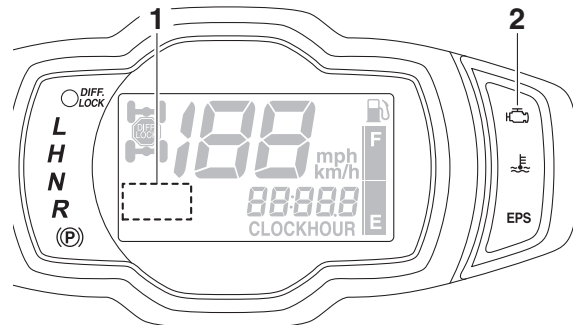

1. Error code display
2. Engine trouble warning light "H"

This model is equipped with a self-diagnosis device for various electrical circuits.

If a problem is detected in any of those circuits, the engine trouble warning light will come on or flash, and the display will indicate an error code.

If the display indicates an error code, note the code number and have a Yamaha dealer check the vehicle.

NOTICE

If the multi-function display indicates an error code, the vehicle should be checked as soon as possible in order to avoid engine damage.

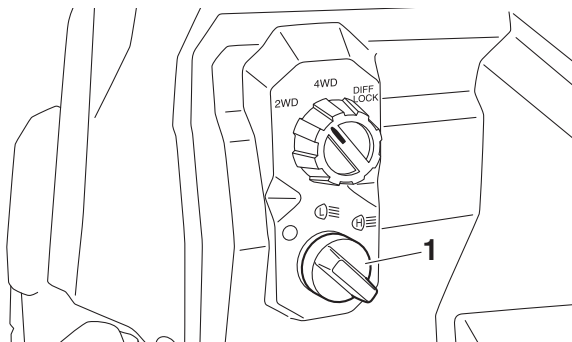
Light switch “○/L≡/H≡”

1. Light switch “○/L≡/H≡”

Set the switch to “L≡” to turn on the low beam and the taillights.

Set the switch to “H≡” to turn on the high beam and the taillights.

Set the switch to “○” to turn off the headlights and taillights.

NOTICE

Do not use the headlights with the engine turned off for an extended period of time. The battery may discharge to the point that the starter motor will not operate properly. If this should happen, remove the battery and recharge it.

On-Command drive knob “2WD/4WD/DIFF LOCK”

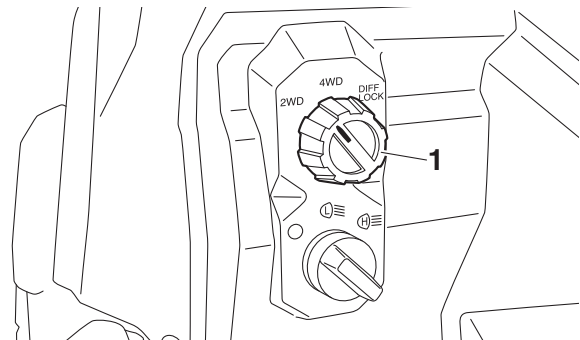

1. On-Command drive knob “2WD/4WD/DIFF LOCK”

This vehicle is equipped with an On-Command drive knob to select the drive mode. The knob has three positions: “2WD”, “4WD”, and “DIFF LOCK”. Select the appropriate drive according to terrain and conditions.

- “2WD” (two-wheel drive): Power is supplied to the rear wheels only.
- “4WD” (four-wheel drive): Power is supplied to the rear and front wheels.

- “DIFF LOCK” (four-wheel drive with the differential gear locked): Power is supplied to the rear and front wheels with the differential gear locked. Unlike the “4WD” mode, all wheels turn at the same speed regardless of traction.

Horn switch “”

Press the switch to sound the horn.

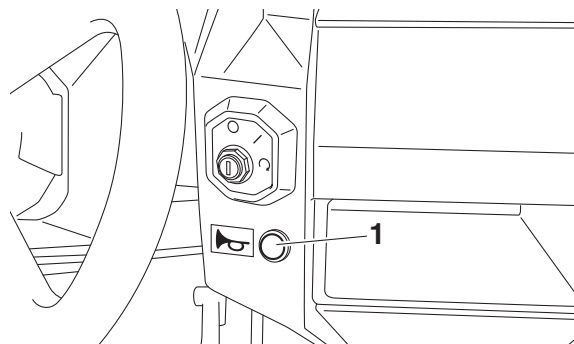

1. Horn switch “”

EBU31411

Accelerator pedal

Press the accelerator pedal to increase engine speed. Spring tension returns the pedal to the rest position when released. Always check that the accelerator pedal returns normally before starting the engine.

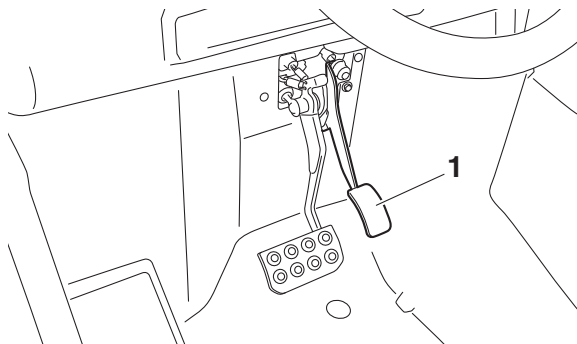

1. Accelerator pedal

EBU31420

Brake pedal

Press the brake pedal to slow or stop the vehicle.

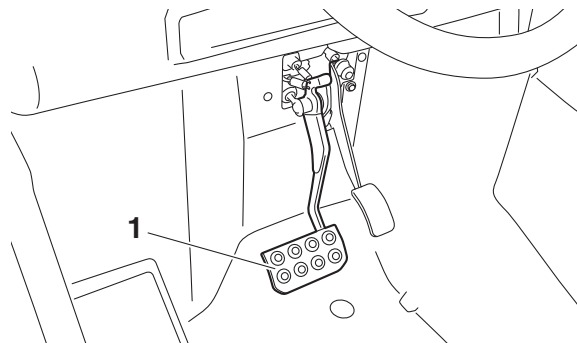

1. Brake pedal

EBU33451

Parking brake lever

The parking brake lever is located at the right side of the driver's seat. Setting the parking brake lever will help keep the vehicle from moving while parked.

To set the parking brake, pull the lever rearward completely.

To release the parking brake, pull rearward on the lever, press the release button, and then push the lever all the way forward.

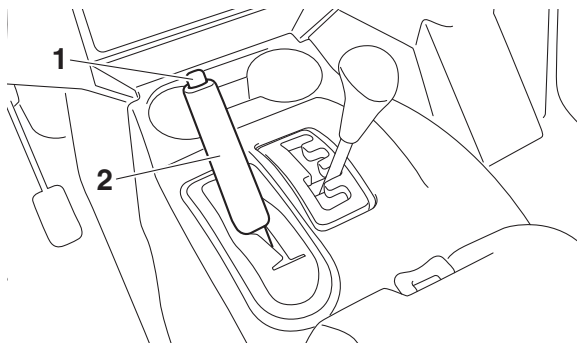

1. Release button
2. Parking brake lever

- TIP** _____
- Spring tension helps return the lever to the released position.
 - If you drive the vehicle with the parking brake engaged, a buzzer will sound.
-

EBU31440

Drive select lever

The drive select lever is used to shift the vehicle into the low, high, neutral, and reverse positions. (Refer to page 6-3 for the drive select lever operation.)

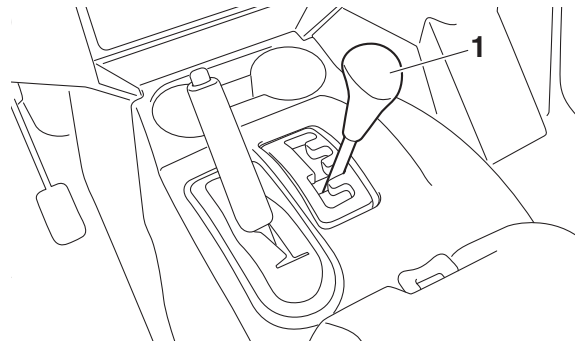

1. Drive select lever

Fuel tank cap

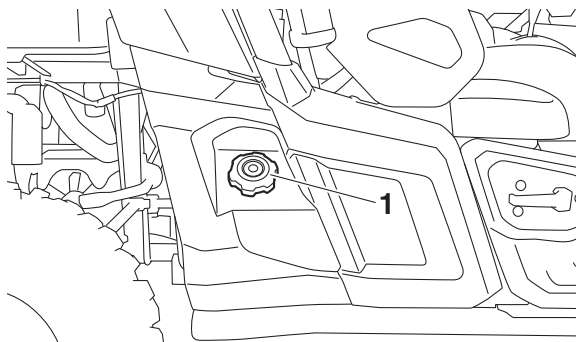

1. Fuel tank cap

To open

Remove the fuel tank cap by turning it counterclockwise.

To close

Install the fuel tank cap by turning it clockwise.

Doors

To open a door, pull the latch outward. To close a door, push or pull the door inward until it is securely latched. Be sure the door is **SECURELY LATCHED AFTER CLOSING IT**.

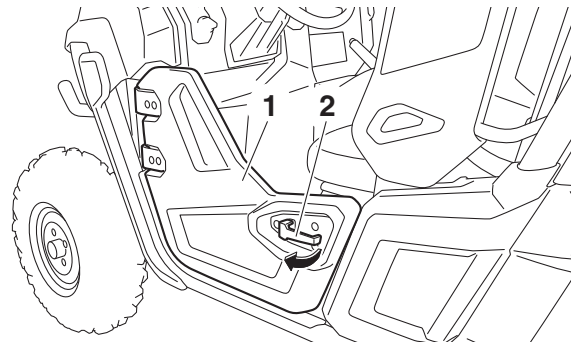

1. Door
2. Latch

Seats

To remove a seat cushion, lift the front of the cushion, and then pull the cushion off.

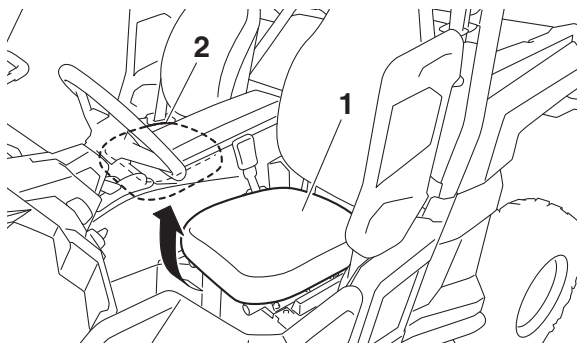

1. Driver seat cushion
2. Passenger seat cushion

To install a seat cushion, insert the projections on the rear of the seat cushion under the seat frame, and then insert the projection on the front of the cushion into the grommet while pushing the cushion downward. Make sure the seats are properly secured before starting off. **WARNING! A loose seat could cause the operator to lose control, or cause the operator or passenger to fall.** [EWB03510]

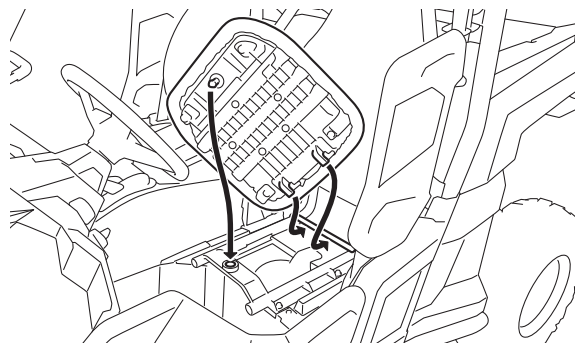

EBU31480

Adjusting the driver seat position

The driver seat can be adjusted to one of three positions to suit the driver's preference.

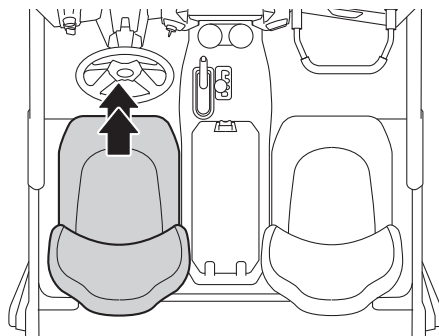

Adjust the driver seat position as follows.

1. Remove the driver seat cushion. (See the previous section “Seats”.)
2. Remove the bolts.

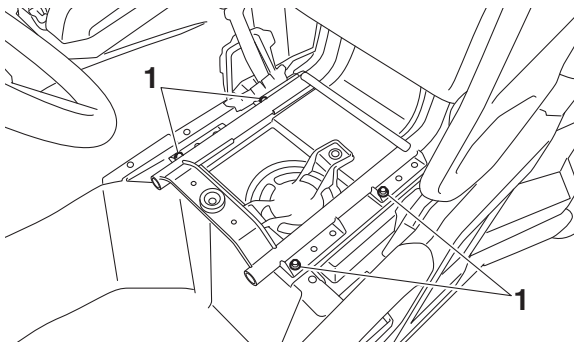

1. Bolt

3. Move the seat frame to the desired position and align the bolt holes in the seat frame with the bolt holes in the vehicle frame.

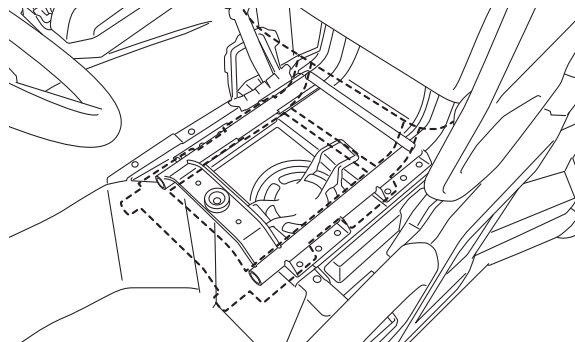

4

4. Install the bolts, and then tighten the bolts to the specified torque.

Tightening torque:

Driver seat bolt:

23 N·m (2.3 kgf·m, 17 lb·ft)

5. Install the cushion.

EBU33471

Seat belts

This vehicle is equipped with three-point seat belts for the driver and passenger. Always wear the seat belts properly while riding in the vehicle. See page 7-5 for more information.

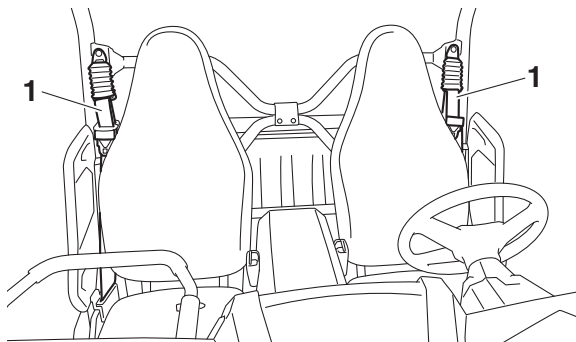

1. Seat belt

TIP

If you shift the transmission into gear without wearing your seatbelt, a buzzer will sound.

EBU31501

Glove compartment

This vehicle is equipped with a glove compartment.

When storing any documents in the glove compartment, be sure to wrap them in a plastic bag so that they will not get wet. When washing the vehicle, be careful not to let any water enter the glove compartment.

ECB02071

NOTICE

To protect from damage, do not put metal items, like tools, or sharply edged items directly in the glove compartment. If they must be stored, wrap them in appropriate cushioning material.

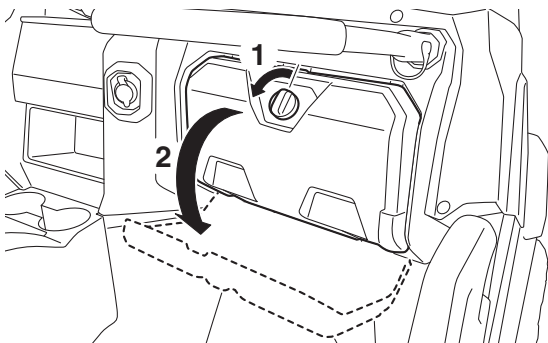

1. Unlock.
2. Open.

EBU33521

Storage compartments

The storage compartments are located under the multi-function meter, between the driver seat and the passenger seat, and under the passenger seat. To access the under-passenger seat storage compartment, remove the passenger seat cushion (see page 4-15 for more information).

When storing any documents in the storage compartments, be sure to wrap them in a plastic bag so that they will not get wet. When washing the vehicle, be careful not to let any water enter the storage compartments.

ECB02241

NOTICE

To protect from damage, do not put metal items, like tools, or sharply edged items directly in the storage compartment. If these items must be stored, wrap them in appropriate cushioning material.

4

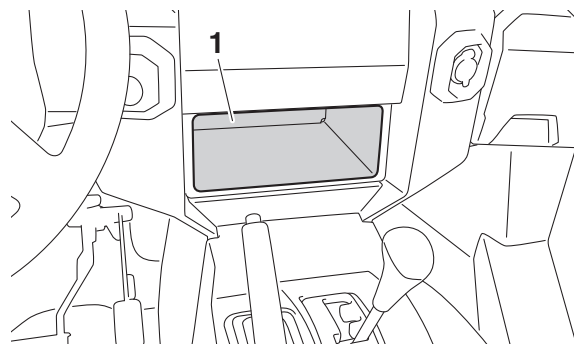

1. Storage compartment

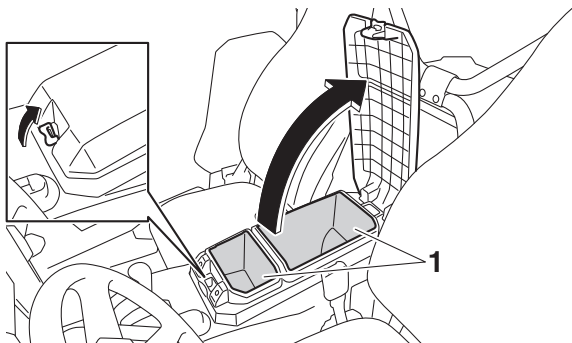

1. Storage compartment

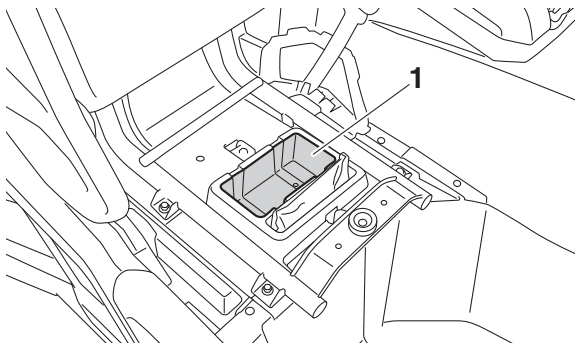

1. Storage compartment

Maximum load limit:

Storage compartment between the driver seat and the passenger seat:

6.4 kg (13.5 lb)

EBU31520

Cup holders

Be sure to tightly close the cap of any plastic bottle before placing it in a cup holder.

Some plastic bottles may not fit into the cup holders depending on their size and shape.

EWB03240

! WARNING

- **Never ride with any open or glass containers in the cup holders; otherwise, the contents may spill and the glass containers may be thrown about and break, and possibly injure people in the vehicle during sudden braking or an accident.**
- **Do not place any other items than sealable plastic containers in the cup holders; otherwise, they may be thrown**

about and possibly injure people in the vehicle during sudden braking or an accident.

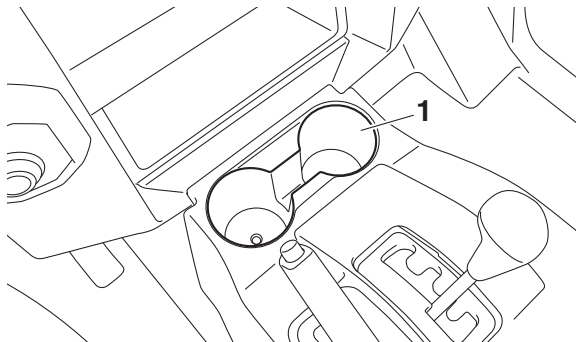

1. Cup holder

EBU33630

Cargo bed

EWB03250



WARNING

- Never carry passengers in the cargo bed.

- Do not exceed the specified maximum load limits. Heavier cargo could cause loss of control because of improper weight balance.
-

There are six cargo hooks in the cargo bed.

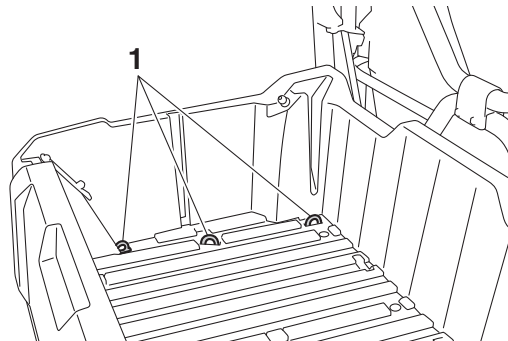

1. Cargo hook

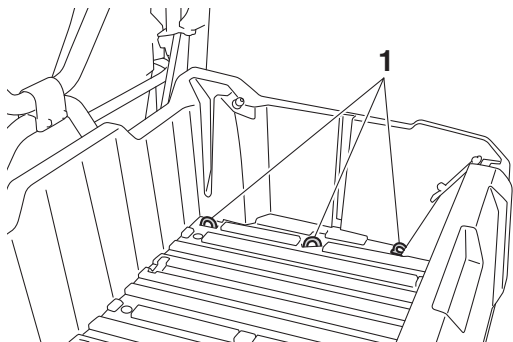

1. Cargo hook

Maximum load limit: 136.0 kg (300 lb)

For additional loading information, see page 6-7.

Removing and installing the tailgate

To remove the tailgate

Unhook the latches, and then pull up the tailgate.

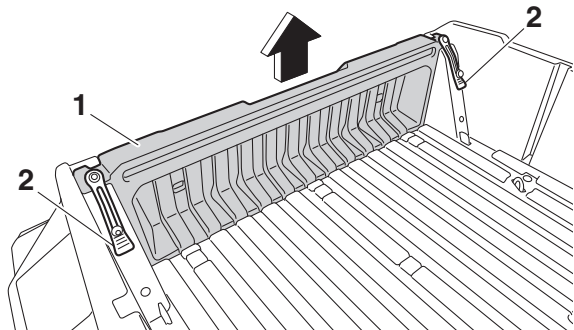

1. Tailgate

2. Latch

To install the tailgate

Place the tailgate in the original position, and then hook the latches.

The tailgate can also be installed at the front of the cargo bed. Install the tailgate and hook the latches as shown.

⚠ WARNING

- **Suspension components become hot during operation. Never touch the compression damping force adjusting bolt and screw, the rebound damping force adjusting screw or the oil reservoir with your bare hand or skin until suspension components have cooled.**
- **Always adjust the shock absorber assemblies on the left and right side to the same setting. Uneven adjustment can cause poor handling and loss of stability, which could lead to an accident.**

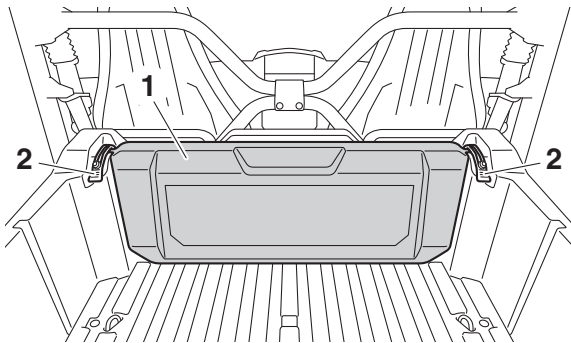

1. Tailgate
2. Latch

EBU33611

Adjusting the front shock absorber assemblies

These shock absorber assemblies are equipped with a spring preload adjusting nut, a rebound damping force adjusting screw, a compression damping force adjusting bolt (for fast compression damping), and a compression damping force adjusting screw (for slow compression damping).

ECB00091

NOTICE

Never turn an adjusting mechanism beyond the minimum and maximum settings.

TIP

Although the total number of clicks or turns of a damping force adjusting mechanism may not exactly match the following specifications

due to small differences in production, the actual number of clicks or turns always represents the entire adjusting range. To obtain a precise adjustment, it would be advisable to check the number of clicks or turns of each damping force adjusting mechanism and to modify the specifications as necessary.

Spring preload

1. Loosen the locknut.
2. Turn the spring preload adjusting nut in direction (a) to increase the spring preload and thereby harden the suspension, and in direction (b) to decrease the spring preload and thereby soften the suspension.

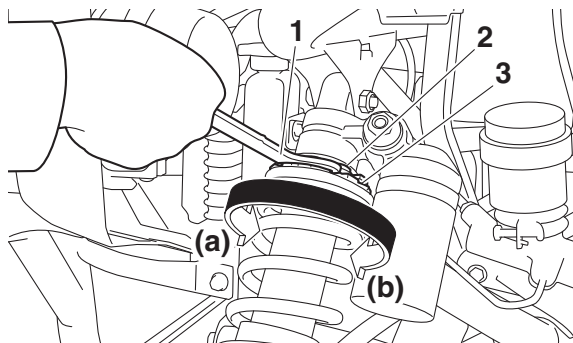

1. Special wrench
2. Locknut
3. Spring preload adjusting nut

TIP

- A special wrench can be obtained at a Yamaha dealer to make this adjustment.
- The spring preload setting is determined by measuring distance A, shown in the illustration. The shorter distance A is, the higher the spring preload; the longer distance A is, the lower the spring preload. With each complete turn of the adjusting nut, distance A is changed by 1.5 mm (0.06 in).

Spring preload setting:

Minimum (soft):

Distance A = 313.5 mm (12.34 in)

Standard:

Distance A = 305.5 mm (12.03 in)

Maximum (hard):

Distance A = 298.5 mm (11.75 in)

Tightening torque:

Locknut:

30 N·m (3.0 kgf·m, 22 lb·ft)

Rebound damping force

Turn the rebound damping force adjusting screw in direction (a) to increase the rebound damping force and thereby harden the damping, and in direction (b) to decrease the rebound damping force and thereby soften the damping.

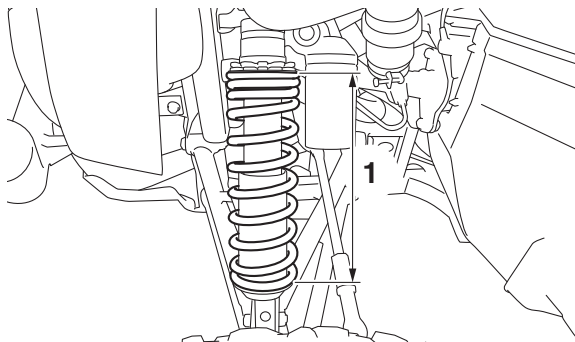

1. Distance A

3. Tighten the locknut to the specified torque. **NOTICE: Always tighten the locknut against the adjusting nut, and then tighten it to the specified torque.**

[ECB00082]

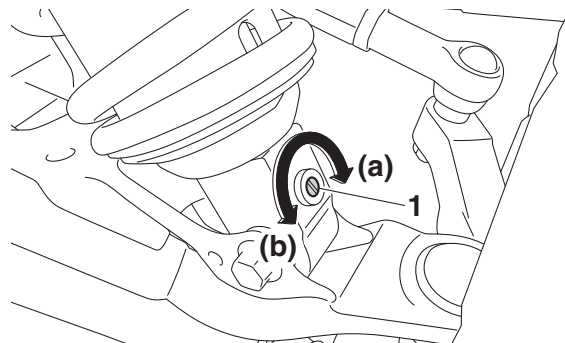

1. Rebound damping force adjusting screw

Rebound damping setting:

Minimum (soft):

30 click(s) in direction (b)*

Standard:

13 click(s) in direction (b)*

Maximum (hard):

1 click(s) in direction (b)*

* With the adjusting screw fully turned in direction (a)

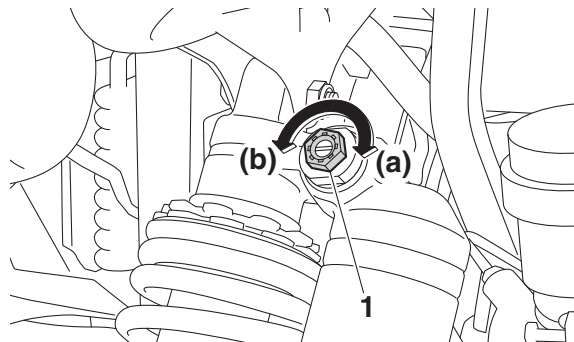

1. Compression damping force adjusting bolt (for fast compression damping)

Compression damping forceCompression damping force (for fast compression damping)

To increase the compression damping force and thereby harden the compression damping, turn the compression damping force adjusting bolt in direction (a). To decrease the compression damping force and thereby soften the compression damping, turn the adjusting bolt in direction (b).

Compression damping setting (for fast compression damping):

Minimum (soft):

2 turn(s) out from the fully turned in position

Standard:

1 1/4 turn(s) out from the fully turned in position

Maximum (hard):

Adjusting bolt fully turned in

Compression damping force (for slow compression damping)

To increase the compression damping force and thereby harden the compression damping, turn the compression damping force adjusting screw in direction (a). To decrease the compression damping force and thereby soften the compression damping, turn the adjusting screw in direction (b).

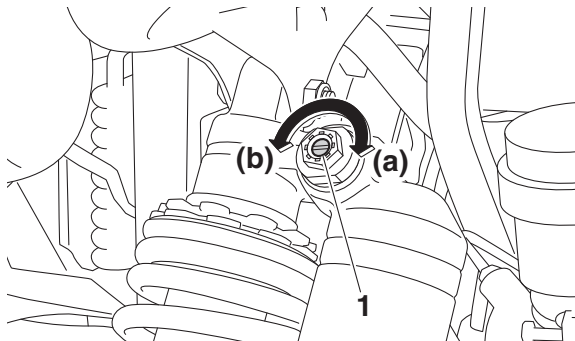

1. Compression damping force adjusting screw (for slow compression damping)

Compression damping setting (for slow compression damping):

Minimum (soft):

18 click(s) in direction (b)*

Standard:

12 click(s) in direction (b)*

Maximum (hard):

1 click(s) in direction (b)*

* With the adjusting screw fully turned in direction (a)

EWB00411

⚠ WARNING

These shock absorber assemblies contain highly pressurized nitrogen gas. Read and understand the following information before handling the shock absorber assemblies.

- **Do not tamper with or attempt to open the cylinder assemblies.**
- **Do not subject the shock absorber assemblies to an open flame or other high heat source. This may cause the unit to explode due to excessive gas pressure.**

- Do not deform or damage the cylinders in any way. Cylinder damage will result in poor damping performance.
- Do not dispose of a damaged or worn out shock absorber assembly yourself. Take the shock absorber assembly to a Yamaha dealer for any service.

EBU33620

Adjusting the rear shock absorber assemblies

These shock absorber assemblies are equipped with a spring preload adjusting nut, a rebound damping force adjusting screw, a compression damping force adjusting bolt (for fast compression damping), and a compression damping force adjusting screw (for slow compression damping).

EVB02492

WARNING

- **Suspension components become hot during operation. Never touch the compression damping force adjusting bolt**

and screw, the rebound damping force adjusting screw or the oil reservoir with your bare hand or skin until suspension components have cooled.

- **Always adjust the shock absorber assemblies on the left and right side to the same setting. Uneven adjustment can cause poor handling and loss of stability, which could lead to an accident.**

ECB00091

NOTICE

Never turn an adjusting mechanism beyond the minimum and maximum settings.

TIP

Although the total number of clicks or turns of a damping force adjusting mechanism may not exactly match the following specifications due to small differences in production, the actual number of clicks or turns always represents the entire adjusting range. To obtain a precise adjustment, it would be advisable to

check the number of clicks or turns of each damping force adjusting mechanism and to modify the specifications as necessary.

Spring preload

1. Loosen the locknut.
2. Turn the spring preload adjusting nut in direction (a) to increase the spring preload and thereby harden the suspension, and in direction (b) to decrease the spring preload and thereby soften the suspension.

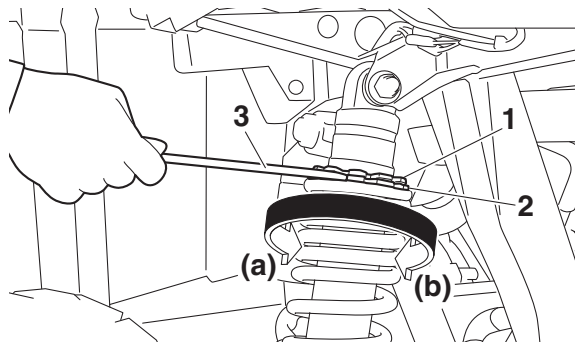

1. Locknut
2. Spring preload adjusting nut
3. Special wrench

TIP

- A special wrench can be obtained at a Yamaha dealer to make this adjustment.
 - The spring preload setting is determined by measuring distance A, shown in the illustration. The shorter distance A is, the higher the spring preload; the longer distance A is, the lower the spring preload. With each complete turn of the adjusting nut, distance A is changed by 1.5 mm (0.06 in).
-

Spring preload setting:

Minimum (soft):

Distance A = 386.0 mm (15.20 in)

Standard:

Distance A = 378.0 mm (14.88 in)

Maximum (hard):

Distance A = 372.0 mm (14.65 in)

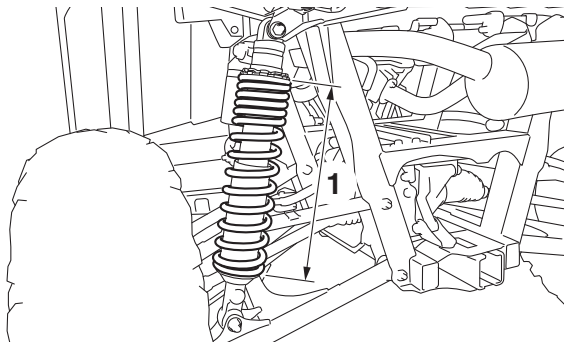

1. Distance A

3. Tighten the locknut to the specified torque. **NOTICE: Always tighten the locknut against the adjusting nut, and then tighten it to the specified torque.**

[ECB00082]

Tightening torque:

Locknut:

30 N·m (3.0 kgf·m, 22 lb·ft)

Rebound damping force

Turn the rebound damping force adjusting screw in direction (a) to increase the rebound damping force and thereby harden the damping, and in direction (b) to decrease the rebound damping force and thereby soften the damping.

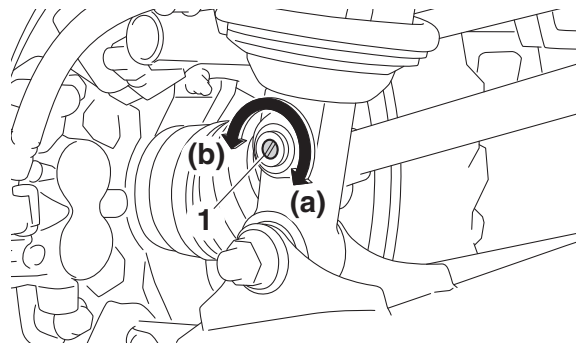

1. Rebound damping force adjusting screw

Rebound damping setting:

Minimum (soft):

30 click(s) in direction (b)*

Standard:

14 click(s) in direction (b)*

Maximum (hard):

1 click(s) in direction (b)*

* With the adjusting screw fully turned in direction (a)

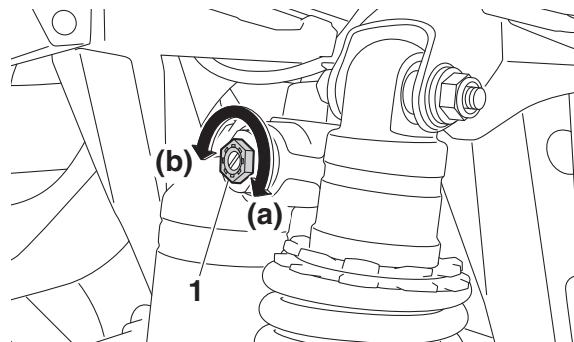

1. Compression damping force adjusting bolt (for fast compression damping)

Compression damping force

Compression damping force (for fast compression damping)

To increase the compression damping force and thereby harden the compression damping, turn the compression damping force adjusting bolt in direction (a). To decrease the compression damping force and thereby soften the compression damping, turn the adjusting bolt in direction (b).

Compression damping setting (for fast compression damping):

Minimum (soft):

2 turn(s) out from the fully turned in position

Standard:

1 1/4 turn(s) out from the fully turned in position

Maximum (hard):

Adjusting bolt fully turned in

Compression damping force (for slow compression damping)

To increase the compression damping force and thereby harden the compression damping, turn the compression damping force adjusting screw in direction (a). To decrease the compression damping force and thereby soften the compression damping, turn the adjusting screw in direction (b).

4

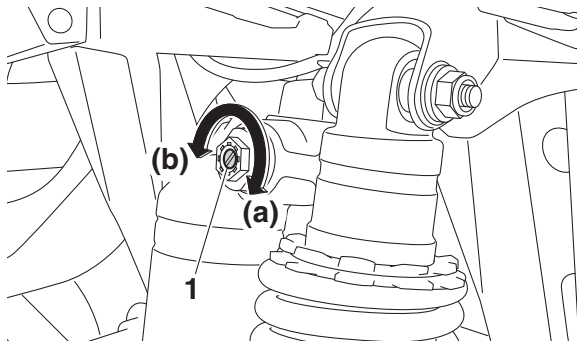

1. Compression damping force adjusting screw (for slow compression damping)

Compression damping setting (for slow compression damping):

Minimum (soft):

18 click(s) in direction (b)*

Standard:

12 click(s) in direction (b)*

Maximum (hard):

1 click(s) in direction (b)*

* With the adjusting screw fully turned in direction (a)

EWB03500

! WARNING

These shock absorber assemblies contain highly pressurized nitrogen gas. Read and understand the following information before handling the shock absorber assemblies.

- **Do not tamper with or attempt to open the cylinder assemblies.**
- **Do not subject the shock absorber assembly to an open flame or other high heat source. This may cause the unit to explode due to excessive gas pressure.**

- Do not deform or damage the cylinders in any way. Cylinder damage will result in poor damping performance.
- Do not dispose of a damaged or worn out shock absorber assembly yourself. Take the shock absorber assembly to a Yamaha dealer for any service.

EBU31550

Trailer hitch bracket and receiver

This vehicle is equipped with a trailer hitch bracket and a 5 cm (2 in) receiver for a standard trailer hitch. Trailer towing equipment can be obtained at a Yamaha dealer. (See page 6-7 for precaution information.)

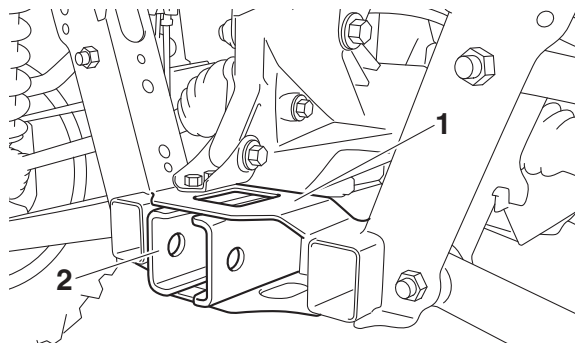

1. Trailer hitch bracket
2. Receiver

EBU32950

Auxiliary DC jack

The auxiliary DC jack is located at the right side of the storage compartment under the multi-function meter. The auxiliary DC jack can be used for suitable work lights, radios, etc. The auxiliary DC jack should only be used when the engine is running and the headlights are turned off.

NOTICE

- **Do not use accessories requiring more than the stated maximum capacity. Doing so may overload the circuit and cause the fuse to blow.**
- **If accessories are used without the engine running, the battery may discharge.**
- **Do not use an automotive cigarette lighter or other accessories with a plug that gets hot, because the jack can be damaged.**

4

1. Set the light switch to “”.
2. Turn the accessory off.
3. Start the engine. (See page 6-2.)
4. Open the auxiliary DC jack cap, and then insert the accessory power plug into the jack.

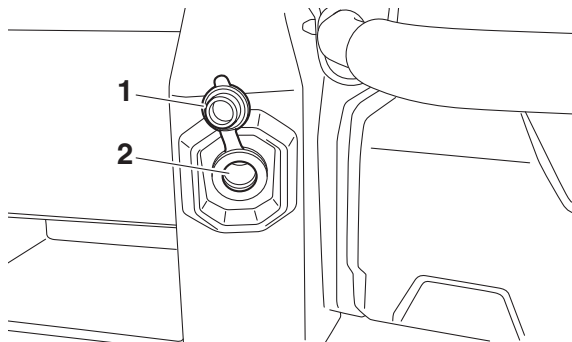

1. Auxiliary DC jack cap
2. Auxiliary DC jack

Maximum rated capacity for the auxiliary DC jack:
DC 12 V, 10 A (120 W)

5. Turn the accessory on.
6. When the auxiliary DC jack is not being used, cover it with the cap.

FOR YOUR SAFETY – PRE-OPERATION CHECKS

Inspect your vehicle each time you use it to make sure the vehicle is in safe operating condition. Always follow the inspection and maintenance procedures and schedules described in the Owner's Manual.

EWB00482



Failure to inspect or maintain the vehicle properly increases the possibility of an accident or equipment damage. Do not operate the vehicle if you find any problem. If a problem cannot be corrected by the procedures provided in this manual, have the vehicle inspected by a Yamaha dealer.

5

Before using this vehicle, check the following points:

ITEM	ROUTINE	PAGE
Brakes	<ul style="list-style-type: none"> • Check operation, free play, fluid level, and fluid leakage. • Fill with DOT 4 brake fluid if necessary. 	5-3, 8-38, 8-42
Parking brake	<ul style="list-style-type: none"> • Check for proper operation. 	8-42
Fuel	<ul style="list-style-type: none"> • Check fuel level. • Fill with the recommended fuel if necessary. 	5-3
Engine oil	<ul style="list-style-type: none"> • Check oil level. • Fill with oil to proper level if necessary. 	5-5, 8-14

ITEM	ROUTINE	PAGE
Coolant	<ul style="list-style-type: none">• Check coolant level in reservoir.• Fill with coolant if necessary.	5-6, 8-24
Final gear oil/Differential gear oil	<ul style="list-style-type: none">• Check for leakage.	5-6, 5-6, 8-20, 8-22
Accelerator pedal	<ul style="list-style-type: none">• Check free play and for proper operation.	5-6
Seat belts	<ul style="list-style-type: none">• Check for proper operation and belt wear.	5-6
Passenger handhold	<ul style="list-style-type: none">• Check for stability and proper fastening.	5-7, 7-8
Steering	<ul style="list-style-type: none">• Check for proper operation.	5-7
Fittings and fasteners	<ul style="list-style-type: none">• Check all fittings and fasteners.	5-7
Instruments, lights and switches	<ul style="list-style-type: none">• Check operation, and correct if necessary.	5-7, 8-54, 8-57, 8-57
Wheels and tires	<ul style="list-style-type: none">• Check tire pressure and for wear and damage.	5-8, 8-45, 8-46
Axle boots	<ul style="list-style-type: none">• Check for damage.	8-29

Front and rear brakes

Brake pedal

- Check that there is no free play in the brake pedal. If there is free play, have a Yamaha dealer check the brake system. (See page 8-41.)
- Check the operation of the brake pedal. It should move smoothly and there should be a firm feeling when the brakes are applied. If not, have the vehicle inspected by a Yamaha dealer.

Brake fluid level

Check the brake fluid level. Add fluid if necessary. (See page 8-39.)

Specified brake fluid: DOT 4

Brake fluid leakage

Check to see if any brake fluid is leaking out of the pipe joints or the brake fluid reservoir. Apply the brakes firmly for one minute. If there is any leakage, have the vehicle inspected by a Yamaha dealer.

Brake operation

Check the operation of the brakes at the start of every drive. Test the brakes at slow speed after starting out to make sure they are working properly. If the brakes do not provide proper braking performance, inspect the brake system. (See page 8-38.)

EBU33200

Fuel

Make sure there is sufficient fuel in the tank.

! WARNING

Gasoline and gasoline vapors are extremely flammable. To avoid fires and explosions and to reduce the risk of injury when refueling, follow these instructions.

1. Before refueling, turn off the engine and be sure that no one is sitting in the vehicle.
Never refuel while smoking, or while in the vicinity of sparks, open flames, or other sources of ignition such as the pilot lights of water heaters and clothes dryers.
2. Do not overfill the fuel tank. Because fuel expands when it heats up, heat from the engine or the sun can cause fuel to spill out of the fuel tank.
3. Wipe up any spilled fuel immediately.
4. Be sure the fuel tank cap is closed securely.

! WARNING

Gasoline is poisonous and can cause injury or death. Handle gasoline with care. Never siphon gasoline by mouth. If you should swallow some gasoline or inhale a lot of gasoline vapor, or get some gasoline in your eyes, see your doctor immediately. If gasoline spills on your skin, wash with soap and water. If gasoline spills on your clothing, change your clothes.

Your Yamaha engine has been designed to use regular unleaded gasoline with a research octane number of 91 or higher (95 or higher for Europe). If knocking or pinging occurs, use a different brand of gasoline or premium unleaded gasoline. Unleaded fuel will give you longer spark plug life and reduced maintenance cost.

Recommended fuel:

Regular unleaded gasoline only

For Europe: Regular unleaded gasoline only with a research octane number of 95 or higher

Fuel tank capacity:

36.7 L (9.69 US gal, 8.07 Imp.gal)

Portable fuel containers

If you carry a portable fuel container in the bed of your Yamaha Wolverine, be sure to secure it with the cap tightened before driving the vehicle.

Always place a portable fuel container on the ground before filling it. Before removing the container cap, touch the container with the fuel dispenser nozzle. Keep fuel dispenser nozzle in contact with container inlet when filling. **WARNING! Never refill a fuel container in the bed of any vehicle. Fire may result from a build-up of static electricity. The**

discharge of this build-up while refueling can cause a spark and ignite the gasoline.

[EWB03270]

EBU31750

Engine oil

Make sure the engine oil is at the specified level. Add oil as necessary. (See page 8-14.)

ECB00301

NOTICE

- **In order to prevent clutch slippage (since the engine oil also lubricates the clutch), do not mix any chemical additives. Do not use oils with a diesel specification of “CD” or oils of a higher quality than specified. In addition, do not use oils labeled “ENERGY CONSERVING II” or higher.**
- **Make sure that no foreign material enters the crankcase.**

Recommended engine oil type and quantity:

See page 10-1.

EBU31760

Coolant

Check the coolant level in the coolant reservoir when the engine is cold (the coolant level will vary with engine temperature).

The coolant level is satisfactory if it is between the minimum and maximum level marks on the coolant reservoir. If the coolant level is at or below the minimum level mark, add additional coolant to bring the level up to maximum level mark. If coolant is not available, add distilled water. Change the coolant every two years. (See page 8-24.)

ECB02120

NOTICE

Hard water or salt water is harmful to the engine. You may use soft water if you cannot get distilled water.

Coolant reservoir capacity (up to the maximum level mark):

0.28 L (0.30 US qt, 0.25 Imp.qt)

EBU36020

Final gear

Make sure there is no oil leaking from the final gear case.

EBU36030

Differential gear

Make sure there is no oil leaking from the differential gear case.

EBU31790

Accelerator pedal

Check to see that the accelerator pedal operates correctly. It must operate smoothly and spring back to the idle position fully when released. Have a Yamaha dealer repair as necessary for proper operation.

EBU31800

Seat belts

Make sure that the seat belts are not frayed, torn, stretched, or damaged. The seat belts must move smoothly when pulled out and retract on its own when released. The seat belts must also lock up when quickly pulled out.

The latch plate should click securely into the buckle and release when the release button is pushed firmly. Wash off any dirt or mud that could affect operation. Have a Yamaha dealer repair as necessary for proper operation.

A crash can damage the restraint systems in your vehicle. A damaged restraint system may not properly protect the person using it, resulting in serious injury or death in a crash. To help make sure your restraint systems are working properly after a crash, have them inspected and any necessary replacements made as soon as possible.

EBU31810

Passenger handhold

Check that the handhold bar and its supports are in good condition. Confirm that the locking pins are securely fastened, and then push and pull on the handhold to make sure that it is not loose.

EBU31820

Steering

Park on level ground. Turn the steering wheel right and left. Check for excessive free play, abnormal noises, or a rough feeling. Have a Yamaha dealer repair as necessary for proper operation.

EBU31831

Fittings and fasteners

Always check the tightness of chassis fittings and fasteners before a drive. Take the vehicle to a Yamaha dealer or refer to the Service Manual for correct tightening torque.

EBU31840

Instruments, lights and switches

Check that all instruments, lights and switches are working properly. Correct if necessary.

Control cables

When driving in cold weather, always make sure all control cables work smoothly before starting off. **WARNING! Control cables can freeze in cold weather and you could be unable to control the vehicle.** [EWB03280]

Tires

Check tire pressure regularly to make sure it is at the recommended specifications. Also check for wear and damage.

Tire pressure

Use the tire pressure gauge to check and adjust tire pressures when the tires are cold. Tire pressures must be equal on both sides. **WARNING! Operation of this vehicle with improper tire pressure may cause severe injury or death from loss of control or roll-over. Tire pressure below the minimum**

specified could also cause the tire to dislodge from the rim under severe driving conditions. [EWB04120]

Set tire pressures to the following specifications:

Recommended tire pressure:

Vehicle load:

0 - maximum

Front:

75.0 kPa (0.750 kgf/cm², 11 psi)

Rear:

75.0 kPa (0.750 kgf/cm², 11 psi)

Minimum tire pressure:

Vehicle load:

0 - maximum

Front:

70.0 kPa (0.700 kgf/cm², 10 psi)

Rear:

70.0 kPa (0.700 kgf/cm², 10 psi)

Maximum vehicle load*:

327.0 kg (721 lb)

* Total weight of operator, passenger, accessories, cargo, and (if applicable) trailer tongue weight

The tire pressure gauge is included as standard equipment. Make two measurements of the tire pressure and use the second reading. Dust or dirt in the gauge could cause the first reading to be incorrect.

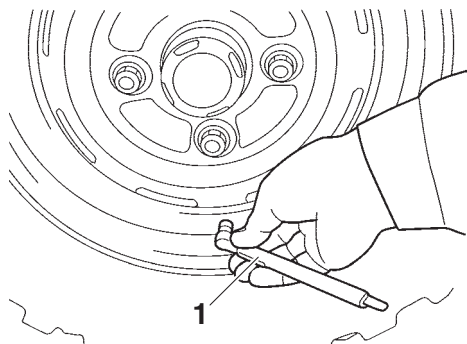

1. Tire pressure gauge

Tire wear limit

When the tire groove decreases to 3 mm (0.12 in) due to wear, replace the tire.

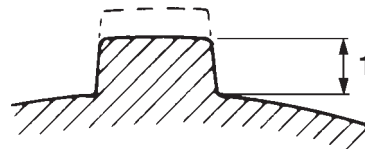

1. Tire wear limit

OPERATION

Read the Owner's Manual carefully to become familiar with all controls. If there is a control or function you do not understand, ask your Yamaha dealer.



6

Failure to familiarize yourself with the controls can lead to loss of control, which could cause an accident or injury.

Engine break-in

There is never a more important period in the life of your vehicle than the period between 0 and 20 hours.

For this reason, we ask that you read the following material carefully. Because the engine is brand new, you must not put an excessive load on it for the first several hours of operation. During the first 20 hours, the various

parts in the engine wear and polish themselves to achieve the correct operating clearances.

During this period, prolonged full-throttle operation or any condition that might result in excessive engine heating must be avoided. However, momentary (2–3 seconds maximum) full-throttle operation under load does not harm the engine.

Each full-throttle acceleration sequence should be followed with a substantial rest period for the engine, by cruising at lower r/min so the engine can rid itself of the temporary build-up of heat. If any abnormality is noticed during this period, consult a Yamaha dealer.

0–10 hours:

Avoid continuous operation above 1/2-throttle. Allow a cooling-off period of 5 to 10 minutes after every hour of operation. Vary the speed of the vehicle from time to time. Do not operate it at one set throttle position.

10–20 hours:

Avoid prolonged operation above three-quarter throttle.

After break-in:

The vehicle may now be operated normally.

EBU33081

Starting the engine

1. Turn the key to “ I ” (on).

ECB02291

NOTICE

The coolant temperature warning light and engine trouble warning light should come on, then go off.

The EPS warning light should come on, then go off when the engine is started.

To avoid possible damage, do not operate the vehicle if a warning light does not work as described above.

2. Apply the brake pedal.
3. Shift the drive select lever into the neutral position.

- When the drive select lever is in the neutral position, the neutral indicator light should come on. If the neutral indicator light does not come on, ask a Yamaha dealer to inspect the electric circuit.
- The engine can be started in any gear if the brake pedal is applied. However, it is recommended to shift into neutral before starting the engine.

4. With your foot off the accelerator pedal, start the engine by turning the key to “  ” (start).

If the engine fails to start, release the key, and then try starting it again. Wait a few seconds before the next attempt. Each attempt should be as short as possible, to preserve battery energy. **NOTICE: Do not crank the engine more than 5 seconds on each attempt, or starter damage could occur. Wait at least 5 seconds between each operation of the electric starter to let it cool.** [ECB02140]

Do not turn the key to the “” (start) position with the engine running; otherwise, damage to the electric starter may result.

TIP _____
For maximum engine life, never accelerate hard when the engine is cold!

EBU31911

Drive select lever operation and reverse driving

ECB02150

NOTICE _____

Do not shift without coming to a complete stop and waiting for the engine to return to normal idle speed. Damage to the engine or drive train may occur.

Shifting: neutral to high and high to low

1. Stop the vehicle, and take your foot off the accelerator pedal.

2. Apply the brake pedal, then shift by moving the drive select lever along the shift guide. Make sure that the drive select lever is completely shifted into position.

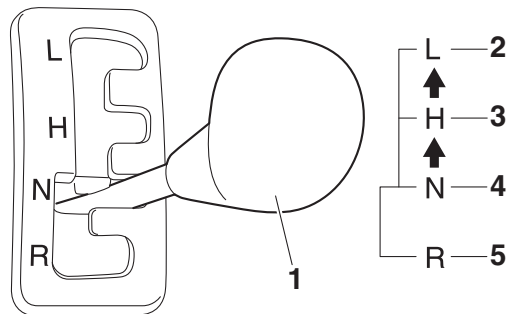

1. Drive select lever
2. L (Low-range)
3. H (High-range)
4. N (Neutral)
5. R (Reverse)

3. Release the parking brake, if applied.
4. Release the brake pedal and press the accelerator pedal gradually.

Shifting: neutral to reverse

EWB03300



Before you shift into reverse, make sure there are no obstacles or people behind you. When it is safe to proceed, go slowly. Hitting an obstacle or person could result in serious injury or death.



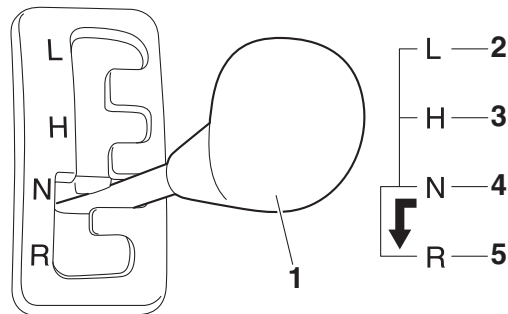





1. Stop the vehicle, take your foot off the accelerator pedal, and check behind you.
2. Apply the brake pedal.
3. Shift from neutral to reverse or vice versa by moving the drive select lever along the shift guide.
 - When in reverse, the reverse indicator light should be on. If the light does not come on, ask a Yamaha dealer to inspect the reverse indicator light electrical circuit.
 - Due to the synchronizing mechanism in the engine, the light may not come on until the vehicle starts moving.



1. Drive select lever
 2. L (Low-range)
 3. H (High-range)
 4. N (Neutral)
 5. R (Reverse)
4. Release the parking brake, if applied.
 5. Check behind the vehicle for people or obstacles, and then release the brake pedal.
 6. Press the accelerator pedal gradually and continue to watch to the rear while backing.

On-Command drive knob

The vehicle handles differently in each of the drive modes (“2WD”, “4WD” and “DIFF LOCK”). For example, the vehicle requires more effort to turn in “DIFF LOCK” than in “2WD”. Always stop the vehicle before changing the position of the On-Command drive knob. The meter display changes according to the selected drive mode. The different drive indicators, and the differential gear lock indicator light “DIFF. LOCK” come on as follows:

Knob position	Indication	Drive mode
<div style="display: flex; justify-content: space-between; font-size: 8px; margin-bottom: 5px;"> 2WD 4WD DIFF LOCK </div> 	<p>No indicator light.</p> <div style="display: flex; align-items: center; justify-content: center;">  /  </div>	<p>“2WD” (two-wheel drive): Power is supplied to the rear wheels.</p>
<div style="display: flex; justify-content: space-between; font-size: 8px; margin-bottom: 5px;"> 2WD 4WD DIFF LOCK </div> 	<div style="display: flex; align-items: center; justify-content: center;">  /  </div>	<p>“4WD” (four-wheel drive): Power is supplied to the rear and front wheels.</p>
<div style="display: flex; justify-content: space-between; font-size: 8px; margin-bottom: 5px;"> 2WD 4WD DIFF LOCK </div> 	<div style="display: flex; align-items: center; justify-content: center;">  /  </div>	<p>“DIFF LOCK” (four-wheel drive with the differential gear locked): Power is supplied to the rear and front wheels and the differential gear is locked. Unlike in four-wheel drive, all wheels turn at the same speed.</p>

TIP

- When the knob is set to “DIFF LOCK” or “4WD”, the differential gear lock indicator and indicator light will flash until the differential gear is completely locked or unlocked.
 - When the indicator and indicator light are flashing, turning the steering wheel back and forth will help the differential gear lock to engage or disengage.
 - Driving with the differential gear not properly engaged or disengaged (e.g., when the indicator and indicator light are flashing) will cause the vehicle speed to be limited until the differential gear is completely engaged or disengaged.
-

Parking

When parking, stop the engine and shift the drive select lever into the neutral position. Apply the parking brake to help prevent the vehicle from rolling. See page 7-16 for more information on parking and parking on a slope.

Loading

6

Take extra precautions when driving with a load or trailer. Follow these instructions and always use common sense and good judgment when carrying cargo or towing a trailer.

Prepare your load or trailer



Improper loading or towing can increase the risk of loss of control, an overturn, or other accident:

- **Do not exceed the Maximum Loading Limits for the vehicle (see “MAXIMUM LOADING LIMIT” in this section and vehicle labeling).**
- **Keep weight in the cargo bed centered side to side, and as low and as far forward as possible. Top-heavy loads increase the risk of overturn. Be sure cargo is secured – a loose load could change handling unexpectedly or strike occupants.**
- **Do not exceed the maximum tongue weight.**
- **Make sure the load does not interfere with your control or ability to see where you are going.**
- **Tie down cargo in the trailer securely. Make sure cargo in the trailer cannot move around. A shifting load can cause an accident.**

Use the hooks equipped on the cargo bed to tie down loads.

Choose a trailer hitch drawbar designed for use with a 5 cm (2 in) receiver. (See page 4-33 for more information.)

You can measure tongue weight with a bathroom scale. Put the tongue of the loaded trailer on the scale with the tongue at hitch height. Adjust the load in the trailer, if necessary, to reduce the weight on hitch. If you are carrying cargo and towing a trailer, include the tongue weight in the maximum vehicle load limit.

MAXIMUM LOADING LIMIT

Vehicle loading limit (total weight of cargo, operator, passenger and accessories and tongue weight): 327.0 kg (721 lb)

Cargo bed: 136.0 kg (300 lb)

Trailer hitch:

Pulling load (total weight of trailer and cargo): 6664 N (680 kgf, 1500 lbf)

Tongue weight (vertical weight on trailer hitch point): 490 N (50 kgf, 110 lbf)

Operating when loaded with cargo or towing a trailer

Drive more slowly than you would without a load. The more weight you carry, the slower you should go. Although conditions vary, it is good practice to keep the vehicle in low gear whenever you are carrying heavier loads or when towing a trailer.

EWB03320



Carrying loads or towing a trailer can increase the risk of loss of control, an overturn, or other accident. To reduce the risk of an accident:

- **Reduce speed, operate in low gear only, and allow more room to stop. A heavier vehicle takes longer to stop.**
- **Avoid hills and rough terrain. Choose terrain carefully. Use extreme caution when towing or carrying a load on inclines.**
- **Turn gradually and go slowly.**

Pulling something other than a trailer

Yamaha recommends that loads be transported in the bed or in a trailer. If you need to move an object a short distance use a winch and follow the winch manufacturer's instructions.

If you choose to use something other than a winch use extreme caution, follow the manufacturer's instructions for that product, and only attach to the hitch or hitch bracket of the

6

Wolverine. **WARNING! Improperly pulling can cause serious injury or death. Never exceed the pulling load limit of the Wolverine. Avoid pulling on inclines.** [EWB03330]

Pulling objects on the ground can be more hazardous than pulling a trailer. It may be difficult to predict how the load will affect vehicle operation. That effect could also change depending upon terrain or what obstacles might be in the object's path.



BASIC GUIDE FOR SAFE USE

As a Wolverine owner you are responsible for the safe and proper operation of this vehicle. Read this chapter and review the safety instructions in Chapter 2 before operating the vehicle. Use these chapters and the labels on the vehicle to instruct new operators and passengers. Do not allow anyone else to operate the vehicle or ride as a passenger if you are unsure that he/she is willing and able to follow these instructions.



WARNING

Follow these instructions to reduce your risk of an accident and to reduce the risk of serious injury or death in the event of an accident.

KNOW YOUR VEHICLE

This off-road vehicle will handle and maneuver differently from cars, ATVs, go-carts, golf-cars and grounds-keeping vehicles. The Wolverine has higher ground clearance and other features to handle rugged terrain, and, as a result, can overturn in situations where some vehicles may not. This would include vehicles made primarily for pavement, roads, improved paths, or grounds-keeping. If you do not use care in maneuvering the Wolverine, you can cause it to roll over even on flat, open areas.

Doing things with a Wolverine that some people do for thrills in other vehicles (such as sideways sliding, skidding, back-wheel sliding, or donuts) have led to side rollovers. These rollovers can result in crushed limbs and other serious injuries or death to drivers or passengers.

As the owner/operator, it is your responsibility to protect yourself and your passenger from accidents, including rollovers. The Wolverine has many features, including a protective structure and seat belts, to help protect occupants, but the best way to avoid injuries is to avoid accidents. There is a risk of injury or death in any accident, even with these safety features.

Driver requirements

- This vehicle is intended for use only by an operator 16 or older with a valid motor vehicle license. Check country laws for minimum age requirements.



- The driver must be able to place both feet flat on the floorboard while seated upright with his/her back against the backrest.
- Do not drive after using drugs or alcohol.
- Remove the ignition key when the vehicle is not in use to prevent unauthorized use of the machine.

Parents:

Many countries have implemented new motor vehicle licensing requirements for young drivers. These requirements are in response to the disproportionately high rate of crashes involving youthful drivers. As with automo-

biles, to promote safe driving behaviors, you should supervise younger drivers and consider setting rules and putting limits on how, when, and where the Wolverine can be used.

Passenger requirements

This vehicle is designed for the operator and one passenger. Allowing passengers to ride improperly can lead to serious injury or death. As the operator, you are responsible for your passenger.

- Your passenger must be able to place both feet on the floorboard while seated upright with his/her back against the backrest.
- Your passenger must be able to reach and hold the passenger handhold.
- Allow only one passenger in the vehicle and only in the designated passenger seat. Do not carry any other passengers. Do not carry passengers in the cargo bed.
- Do not allow someone to ride as a passenger who has been using drugs or alcohol.

- Do not allow children who need child safety seats or booster seats in the Wolverine. The seat belt is not designed to restrain automotive child safety seats.

Occupant protection system

EWB03350



Do not make changes to the occupant protection system. If you install aftermarket products or have your vehicle modified, you may put yourself and others at greater risk of serious injury or death. You are responsible for any such changes to the vehicle.

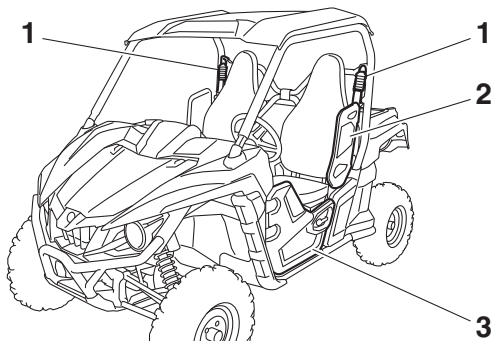

1. Seat belt
2. Shoulder bolster
3. Door

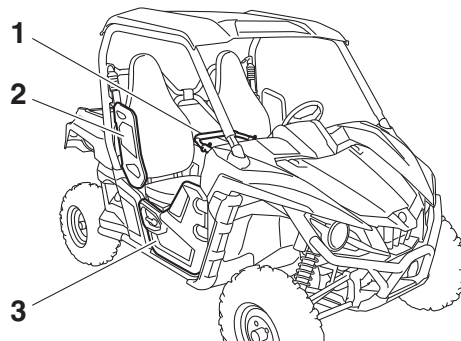

1. Passenger handhold
2. Shoulder bolster
3. Door

The Wolverine comes with a variety of features to help reduce the risk of driver and passenger injury. These features work together, and when properly used, these features will help protect the occupants in the event of an accident. If these features are not used properly, they can cause injury.

Protective structure

The vehicle cage/frame provides a protective structure that helps limit intrusions by branches or other objects and may reduce your risk of injury in accidents. The protective structure will not protect occupants in all rollovers or accidents.

Body parts outside of vehicle can be struck by passing objects or crushed during vehicle rollover. Do not put your hands or feet outside of the vehicle for any reason. Do not hold onto the door, cage/frame or shoulder bolster. Wear your seat belt and helmet.

If you think or feel that the vehicle may tip or roll, do not put your hands or feet outside the vehicle for any reason. You will not be able to stop the vehicle from tipping over using your body. Any part of your body (arms, legs, or head) outside of the vehicle can be crushed by the vehicle cage/frame.

Seat belts

Seat belts should be worn by the driver and passenger. The driver must be sure that the passenger is belted before driving.

- Be sure the seat belt is not twisted, is close-fitting across the hips and chest, and is latched securely.
- Do not wear the seat belt across the abdomen or stomach.
- Do not put the seat belt behind the back.

Failure to use seat belts properly may lead to an increased likelihood and severity of injury. An unbelted occupant may strike the interior of the vehicle, the protective structure, or other objects in an accident or during operation. You may also fall completely out or be partially ejected from the vehicle, which may lead to being crushed between the ground and the vehicle. Wearing the seat belt helps you remain in the vehicle – the doors and passenger handhold are not a substitute for using a seat belt.

A crash can damage the restraint systems in your vehicle. A damaged restraint system may not properly protect the person using it, resulting in serious injury or death in a crash. To help make sure your restraint systems are working properly after a crash, have them inspected and any necessary replacements made as soon as possible.

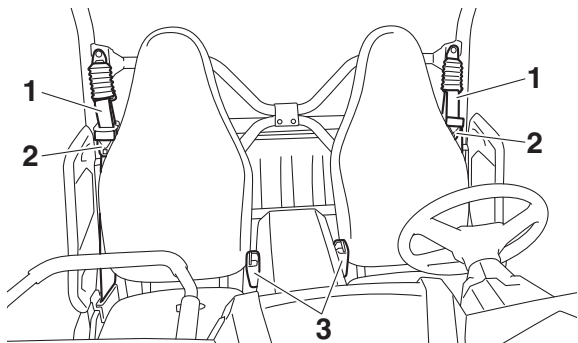

- 1. Seat belt
- 2. Latch plate
- 3. Buckle

To wear the seat belt properly, do the following:

1. Hold the latch plate as you pull the belt across your lap and chest. Make sure the belt is not twisted and is not caught on any portion of the vehicle, your clothing, or any equipment you are carrying.
2. If the latch plate is not positioned in the correct location along the seat belt, squeeze the latch plate ends together along its long edges in order to more easily adjust its location up or down along the length of the belt.

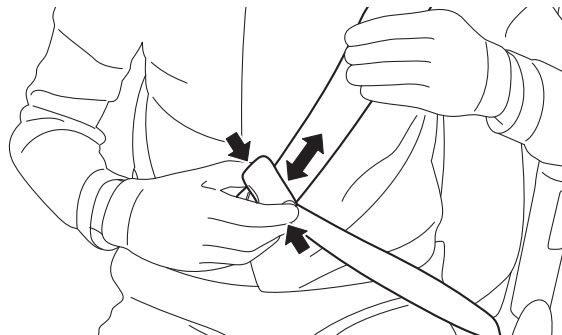

3. Push the latch plate into the buckle until it clicks. Pull up on the latch plate to make sure it is secure.

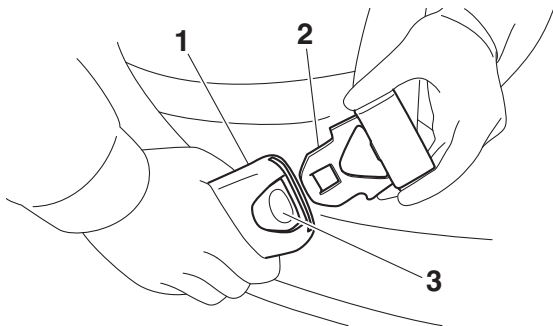

1. Buckle
2. Latch plate
3. Release button

4. Put the lap portion of the belt low on your hips. Pull up on the shoulder part so the belt is snug across your hips. Be sure the seat belt is not caught on the shoulder bolster or other object.

5. Position the shoulder belt over your shoulder and across your chest. The shoulder belt should fit against your chest. If it is loose, pull the belt out all the way and then let it retract.
6. Check if the seat belt shoulder position suits the size of the driver and passenger. To lower the belt, insert the belt into the seat belt height adjuster slot as shown. To raise the belt, remove the belt from the height adjuster slot.

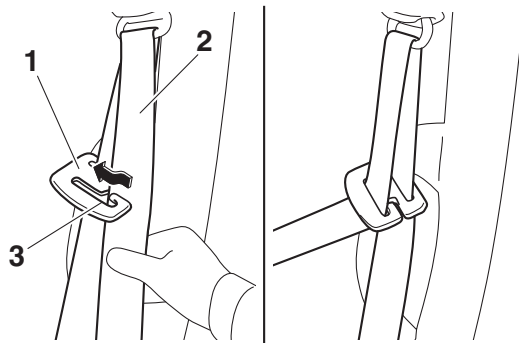

1. Seat belt height adjuster
2. Seat belt
3. Slot

7. To release the buckle, firmly press the release button.

Doors

The doors are designed to reduce the likelihood that you will stick your leg out to stop the vehicle from tipping over or for any other reason in a rollover. The doors may also reduce intrusion of objects into the occupant area. Make sure the door is securely latched before operation. Do not place your arm or hand on the door during operation. Your hand or arm may be struck by objects or crushed against outside objects or the ground during a rollover.

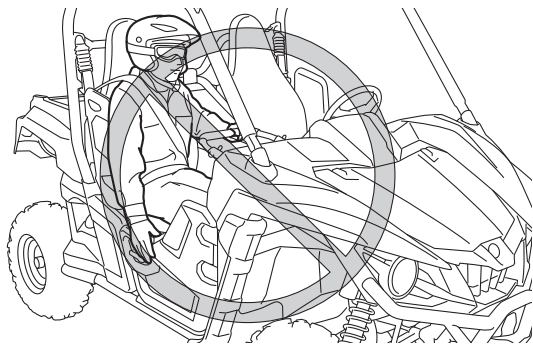

Passenger handhold

The passenger handhold is provided to grip during operation to maintain proper position and balance. Holding onto the handhold helps to reduce the likelihood that the passenger puts a hand outside the vehicle if the vehicle begins to tip.

The driver should make sure the passenger is holding onto the handhold with both hands before operating the vehicle.

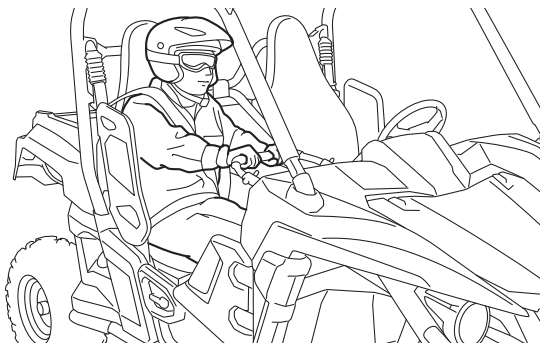

Adjusting the handhold position

The handhold can be adjusted to one of three positions to suit the passenger's preference.

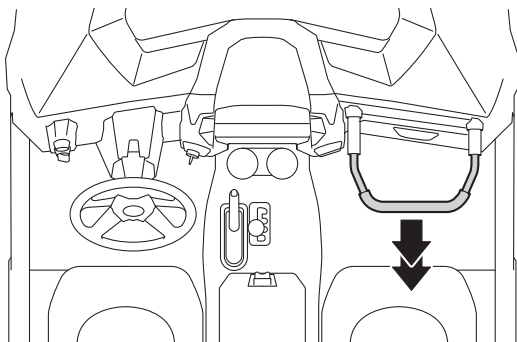

Adjust the handhold position as follows.

1. Remove the locking pins.

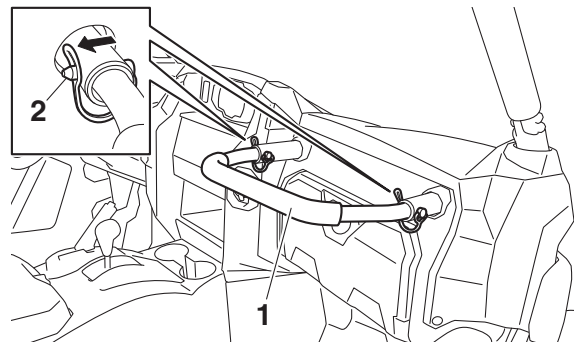

1. Passenger handhold
2. Locking pin

2. Slide the handhold to the desired position and align the holes in the handhold bar with the holes in the handhold supports.

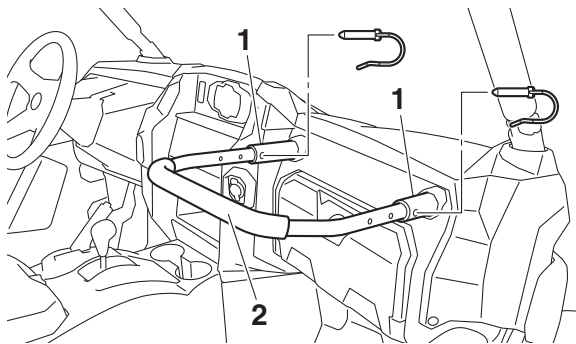

1. Handhold support
2. Handhold bar

7

3. Insert the pins into the holes and secure them with the wire loops. Make sure that the handhold is properly secured before starting off.

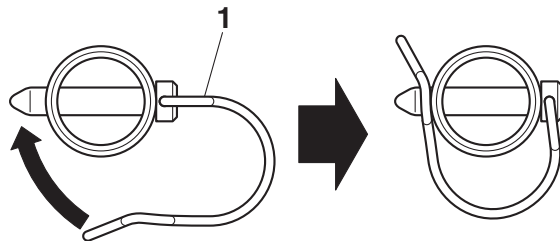

1. Wire loop

Seat and shoulder bolsters

The seats and shoulder bolsters are designed to help keep you in the vehicle. Do not put your hand or arm on or outside of the shoulder bolster during operation. Your hand or arm may be struck by objects or crushed against outside objects or the ground during a rollover.

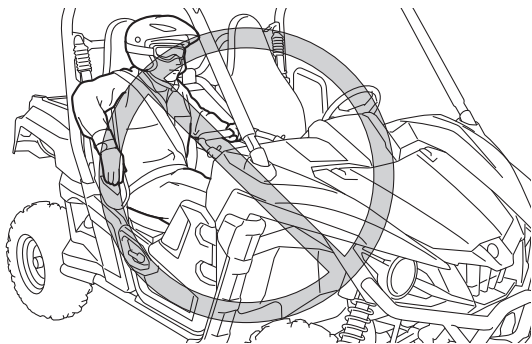

briefly jerk in one direction or back and forth as the tires and vehicle respond to the obstacle. This quick motion could injure your thumbs or wrist if your thumbs or hand(s) are inside the steering wheel. Grip the steering wheel so that your thumbs will not be hit by the spokes. As an example, see the illustration.

Floorboard

The floorboard allows you to brace your feet, which helps you keep your body in the vehicle in the event of an accident or rollover. Keep your feet on the floorboard during operation.

Steering wheel

Keep both hands on the steering wheel. Do not hold the steering wheel with your thumbs inside the rim. Keep your palms on the outside of the steering wheel. Similar to other off-road vehicles, if the Wolverine hits a deep rut or large obstacle, the steering wheel could

LEARNING TO OPERATE YOUR VEHICLE

Personal protective equipment

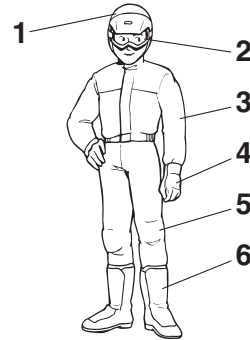
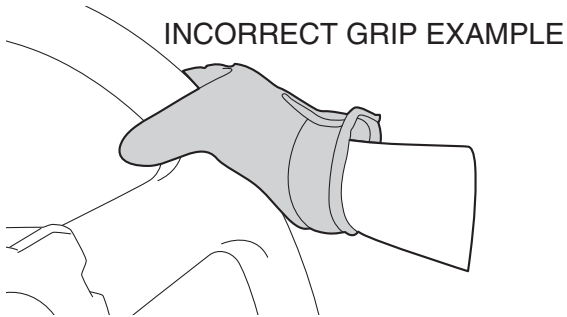
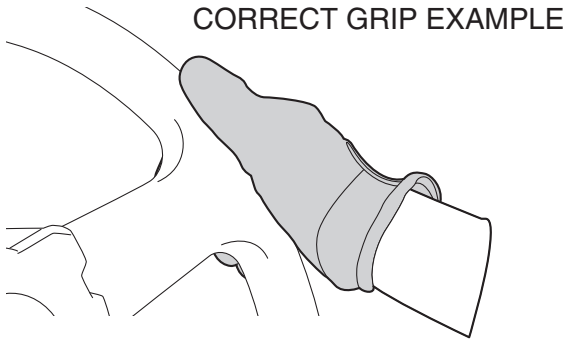

1. Approved motorcycle helmet
2. Eye protection
3. Long-sleeved shirt or jacket
4. Gloves
5. Long pants
6. Over-the-ankle boots

The driver and passenger should wear the following to reduce risk of injury in an accident:

- Approved motorcycle helmet that fits properly

- Eye protection (goggles, helmet face shield, or protective eyewear)
- Over-the-ankle boots, gloves, long-sleeved shirt or jacket, and long pants

An approved helmet and other personal protective equipment can help in a variety of ways, including:

- Reduce the severity of injuries if any part of you is outside the vehicle cage/frame protective structure during a rollover.
- Help protect you if outside objects intrude inside the vehicle during operation.
- Help protect you in the event of vehicle impact with an obstacle.

Wear eye protection when operating or riding in the vehicle to reduce the risk of a serious accident or injury. Eye protection, such as a face shield or goggles, may reduce the risk of foreign material getting in your eyes and help prevent loss of vision.

Practice for new Yamaha Wolverine users

You should become familiar with the performance characteristics of the vehicle in a large, flat area that is free of obstacles and other vehicles. Practice controlling the accelerator pedal, brakes, steering, and drive select lever. Drive at slow speeds with gradual acceleration and turning. Practice smooth throttle application. Practice slowing down before turning. Practice maintaining a steady throttle through the turn. Avoid higher speeds until you are thoroughly familiar with the operation of your vehicle. Remember, driving aggressively or making abrupt maneuvers even on flat, open areas can cause side rollovers.

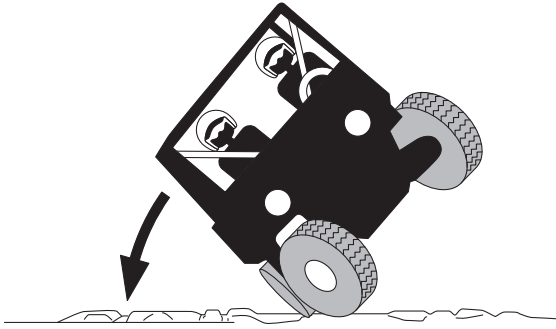

7

Become familiar with the way the vehicle feels in low and high ranges, first in two-wheel drive “2WD” and then in four-wheel drive “4WD” and four-wheel drive with the differential locked “DIFF LOCK”. Steering may take more effort in four-wheel drive with the differential locked “DIFF LOCK”. Also practice driving in reverse.

Take the time to learn basic operation of the vehicle before attempting more difficult maneuvers.

Getting ready to ride

Perform the Pre-Operation Checks on page 5-1. Follow the instructions starting on page 6-2 to start the engine.

Turning

Use care in turns – turning the steering wheel too far or too fast can result in loss of control or a rollover. Slow down before entering turns. When making tight turns from a standstill or at slow speeds, avoid sudden or hard acceleration. Driving aggressively or making abrupt maneuvers even on flat, open areas can cause side rollovers. Avoid sideways sliding, skidding, or back-wheel sliding, and never do donuts. If you feel the Wolverine begin to slide sideways or the back wheels slide during a turn, steer into the direction of the slide, if possible, and gradually let off the accelerator pedal to regain directional control and avoid rollover. For example, if you feel the back of the vehicle start to slide to your right, steer to the right.

If you think or feel that the vehicle may tip or roll, keep your body completely inside the protective structure of the vehicle:

- Brace yourself by pressing your feet firmly on the floorboard and keep a firm grip on the steering wheel or passenger handhold.
- Do not put your hands or feet outside of the vehicle for any reason. Do not try to stop a tipover using your arm or leg.

Accelerating

With the engine idling in neutral and your foot on the brake, shift the drive select lever into low or high. **NOTICE: Do not shift from low to high or vice versa without coming to a complete stop and waiting for the engine to return to normal idle speed – damage to the engine or drive train may occur. Then release the parking brake.** [ECB02160] Press the accelerator pedal slowly and smoothly. The centrifugal clutch will engage and the vehicle will begin to accelerate.

Avoid higher speeds and sudden or hard acceleration until you are thoroughly familiar with the operation of your vehicle. Avoid sudden or hard acceleration in any turn.

Braking

When slowing down or stopping, take your foot off the accelerator pedal and press the brake pedal smoothly. Improper use of the brakes can cause the tires to lose traction, reducing control of the vehicle and increasing the possibility of an accident.

Braking ability is affected by type of terrain. In most cases, gradual application of the brakes is more effective than abrupt braking, particularly on loose surfaces, such as gravel. Always allow for greater braking distance on rough, loose, or slippery surfaces.

Engine braking

Engine compression braking is designed to assist you when operating your Wolverine off-road. With this feature, the engine helps slow

the vehicle down after you take your foot off the accelerator. Engine braking is more noticeable in four-wheel drive. Application of vehicle brakes provides additional stopping power.

Leaving the vehicle

Do not get out of the vehicle while the engine is running and the drive select lever is in any gear. There is a risk of injury because:

- Children or others may accidentally press the accelerator pedal.
- Objects tossed into the vehicle may strike the accelerator pedal.
- The parking brake may not keep the vehicle from accelerating.

Unwanted vehicle movement can cause serious injury or death, and it may be dangerous to try to stop the vehicle.

Parking on a flat area

When parking on a flat area, stop the engine and shift the drive select lever into the neutral position. Apply the parking brake to help prevent the vehicle from rolling.

Parking on a slope

The parking brake acts only on the rear wheels when in “2WD”. For the parking brake to take effect on all four wheels, shift to “DIFF LOCK” before stopping the engine.

If you park on a hill that is too steep, the vehicle may roll out of control. Never park on hills that are so steep you cannot walk up them easily. If you must park on an incline, follow these instructions:

1. Bring the vehicle to a stop by applying the brake pedal.
2. Put the vehicle in “DIFF LOCK”.
3. Turn the key to “” (off).
4. With the brake pedal applied, set the parking brake.

5. Block the front and rear wheels with rocks or other objects.

Loading

The total weight of operator, passenger, accessories, cargo, trailer tongue weight, and the vehicle itself must not exceed 975 kg (2150 lb). Vehicle loading can affect handling. See “Loading” on page 6-7.

EBU33730

Operation on different surfaces and terrains

Go slowly and proceed with caution when operating on an unfamiliar surface or terrain. This vehicle may handle differently in certain types of terrains or on certain surfaces. You may come upon hidden rocks, bumps, or holes without enough time to react. To avoid loss of control or rollover, always be alert to changing surfaces or terrain when operating the vehicle.

Your Yamaha Wolverine has higher ground clearance and other features to handle rugged terrain, and as a result, can overturn in situations where some vehicles may not. Abrupt maneuvers or aggressive driving can cause loss of control, including rollovers – even on flat, open areas. These rollovers can result in crushed limbs and other serious injuries or death to drivers or passengers.

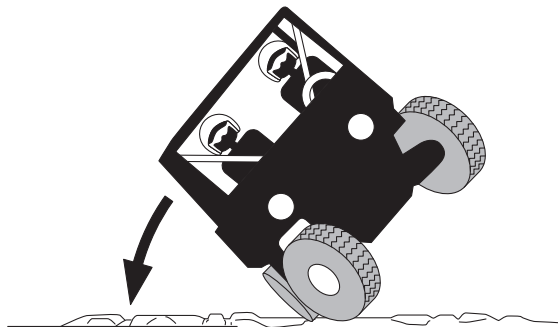

Hills

Choose carefully which hills you attempt to climb or descend. Avoid hills with slippery surfaces or those where you will not be able

to see far enough ahead of you. Use common sense and remember that some hills are too steep for you to climb or descend. Use proper driving techniques to avoid rearward, forward, or sideways rollovers on hills and slopes.

Drive straight up and down inclines, not across them. If crossing a hill is unavoidable, drive slowly. Turn downhill immediately if you feel the vehicle may tip.

7

If you think or feel the vehicle may tip or roll:

- Brace yourself by pressing your feet firmly on the floorboard and keep a firm grip on the steering wheel or passenger handhold.
- Do not put your hands or feet outside of the vehicle for any reason.

Uphill

Do not attempt to climb hills until you have mastered basic maneuvers on flat ground. Drive straight up hills, and avoid crossing the

side of a hill, which increases your risk of roll-over. Practice first on gentle slopes before attempting steeper hills. Always check the terrain carefully before attempting any hill.

To climb a hill, you need traction, momentum, and steady throttle. For more traction and control for climbing steeper and/or rougher slopes, shift into low gear and select “4WD” or “DIFF LOCK”. Travel fast enough to maintain momentum, but not so fast that you cannot react to changes in the terrain as you climb.

Slow down when you reach the crest of the hill if you cannot see clearly what is on the other side – there could be another person, an obstacle, or a sharp drop-off.

If you start to lose traction or momentum when climbing, and decide you will be unable to continue, use the brakes to stop. Do not attempt to turn the vehicle around. With your foot on the brake pedal, look behind you and plan your descent. Shift the drive select lever into reverse so you can use engine braking to

slow your descent. Release the brake and begin to coast down the hill. Use engine braking as much as possible, gently applying the brakes when necessary.

Downhill

Check the terrain carefully before going downhill. When possible, choose a path that lets you drive your vehicle straight downhill. Choose your path carefully and drive slowly enough to be able to react to obstacles that you encounter.

For more traction and control, before going down steeper and/or rougher slopes, shift into low gear and select “4WD” or “DIFF LOCK”. Engine braking will help you go downhill slowly. Go as slowly as possible. If you begin to go too fast, apply the brakes gently. Avoid hard application of the brakes, which could cause the vehicle to slide.

If you are sliding or skidding, try to steer in the direction the vehicle is sliding, to regain control. For example, if you feel the back of the vehicle start to slide to your right, steer to the right.

If you must turn on the hill to avoid an obstacle, do so slowly and carefully. If the vehicle starts to tip, immediately steer in the downhill direction if there are no obstacles in your path. As you regain proper balance, gradually steer again in the direction you want to go.

Rough terrain

Operation over rough terrain should be done with caution.

- Look for and avoid obstacles that could cause damage to the vehicle or could lead to a rollover or accident.
- Do not drive in a way that will get the vehicle airborne, as injury, loss of control, and damage to the vehicle could occur.

Pavement

This vehicle is designed for off-road use only. Avoid paved surfaces. Turn gradually and go slowly if you must drive on pavement.

Water

If you must cross shallow, slow-moving water up to the depth of the vehicle's floorboard, choose your path carefully to avoid sharp drop-offs, large rocks, or slippery surfaces that could cause the vehicle to overturn. Never operate through water deeper than 37 cm (15 in) or fast-flowing water. Choose a path where both your entrance into and exit point from the water is a gradual incline. Determine the water depth and currents before crossing. Operating this vehicle through deep or fast-flowing water can lead to loss of control or overturn. To reduce your risk of drowning or other injuries, use care when crossing through water.

Wet brakes may have reduced effectiveness. After leaving the water, test your brakes. If necessary, apply the brakes several times to let friction dry out the linings.

ECB02170

NOTICE

After driving your vehicle in water, be sure to drain the trapped water by removing the check hoses at the bottom of the air filter case and air duct and the V-belt case drain plug. Wash the vehicle in fresh water if it has been operated in salt water or muddy conditions.

Loose terrain/slippery terrain

When driving on slippery terrain, including wet, muddy, or icy conditions, as well as loose gravel, be aware that you could begin skidding or sliding. To avoid loss of control, slow down and put the vehicle in four-wheel drive before driving on a slippery surface and plan your path to avoid making abrupt maneuvers.

If you feel the vehicle begin to slide sideways or the back wheels slide during a turn, steer into the direction of the slide if possible, to regain directional control. For example, if you feel the back of the vehicle start to slide to your right, steer to the right.

Brush or wooded areas

When operating in areas with brush or trees, watch carefully on both sides and above the vehicle for obstacles such as branches that the vehicle might hit, causing an accident. Watch for brush that might enter the vehicle as you pass and strike you or the passenger. Never hold onto the cage/frame. The passenger should always hold onto the passenger handhold with both hands.

The muffler and other engine parts become extremely hot during operation and remain hot after the engine has stopped. To reduce the risk of fire during operation or after leaving the vehicle, do not let brush, grass and other materials collect under the vehicle, near the

muffler or exhaust pipe, or next to other hot parts. Check under the vehicle after operating in areas where combustible materials may have collected. Do not idle or park the vehicle in long dry grass or other dry ground cover.

Encountering obstacles

If you cannot go around an obstacle, such as a fallen tree or a ditch, stop the vehicle where it is safe to do so. Set the parking brake and get out to inspect the area thoroughly. Look from both your approach side and exit side. If you believe you can continue safely, choose the path that will allow you to get over the obstacle and at as close to a right angle as possible to minimize vehicle tipping. Go only fast enough to maintain your momentum but still give yourself plenty of time to react to changes in conditions.

If there is any question about your ability to maneuver safely over the obstacle, you should turn around if the ground is flat and you have the room or back up until you find a less difficult path.

PERIODIC MAINTENANCE AND ADJUSTMENT

Periodic inspection, adjustment, and lubrication will keep your vehicle in the safest and most efficient condition possible. Safety is an obligation of the vehicle owner/operator. The most important points of vehicle inspection, adjustment, and lubrication are explained on the following pages.

WARNING

Failure to properly maintain the vehicle or performing maintenance activities incorrectly may increase your risk of injury or death during service or while using the vehicle. If you are not familiar with vehicle service, have a Yamaha dealer perform the service.

WARNING

Turn off the engine when performing maintenance unless otherwise specified.

- **A running engine has moving parts that can catch on body parts or clothing and electrical parts that can cause shocks or fires.**
- **Running the engine while servicing can lead to eye injury, burns, fire, or carbon monoxide poisoning - possibly leading to death. See page 2-5 for more information about carbon monoxide.**

WARNING

Brake discs, calipers, drums, and linings can become very hot during use. To avoid possible burns, let brake components cool before touching them.

Owner's manual and tool kit

You are recommended to put this owner's manual in the vinyl bag and always carry it in the glove compartment as shown. Put the owner's tool kit and tire pressure gauge under the passenger seat.

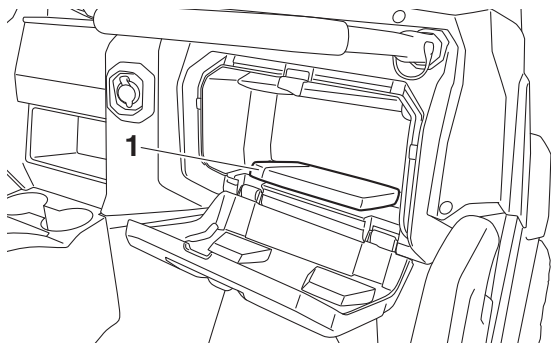

1. Owner's manual

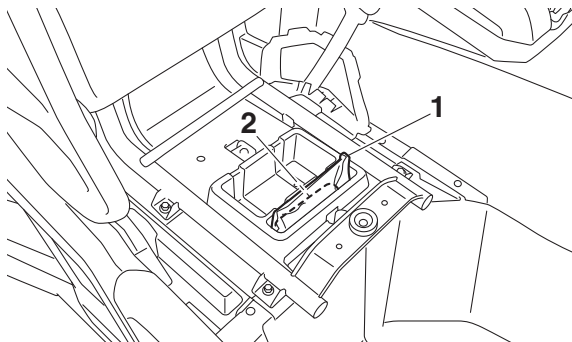

1. Owner's tool kit
2. Tire pressure gauge

The service information included in this manual is intended to provide you, the owner, with the necessary information for completing your own preventive maintenance and minor repairs.

The tools provided in the owner's tool kit are sufficient for this purpose, except that a torque wrench is also necessary to properly tighten nuts and bolts.

If you do not have a torque wrench available during a service operation requiring one, take your vehicle to a Yamaha dealer to check the torque settings and adjust them as necessary.

Periodic maintenance chart for the emission control system

- For vehicles not equipped with an odometer or hour meter, follow the month maintenance intervals.
- For vehicles equipped with an odometer or an hour meter, follow the km (mi) or hours maintenance intervals. However, keep in mind that if the vehicle isn't used for a long period of time, the month maintenance intervals should still be followed.
- Items marked with an asterisk should be performed by a Yamaha dealer as they require special tools, data and technical skills.

NO.	ITEM	ROUTINE	Whichever comes first ⇒	INITIAL			EVERY		
				month	1	3	6	6	12
				km (mi)	320 (200)	1200 (750)	2400 (1500)	2400 (1500)	4800 (3000)
hours	20	75	150	150	300				
1	*	Fuel line	<ul style="list-style-type: none"> • Check fuel hose for cracks or damage. • Replace if necessary. 			√	√	√	
2	*	Valves	<ul style="list-style-type: none"> • Check valve clearance and adjust if necessary. 	Every 2500 km (1600 mi) for the first 7500 km (4800 mi). Every 5000 km (3200 mi) thereafter.					
3		Spark plug	<ul style="list-style-type: none"> • Check condition. • Adjust gap and clean. • Replace if necessary. 	√	√	√	√	√	
4	*	Breather system	<ul style="list-style-type: none"> • Check breather hose for cracks or damage. • Replace if necessary. 			√	√	√	

NO.	ITEM	ROUTINE	Whichever comes first ⇒	INITIAL			EVERY		
				month	1	3	6	6	12
				km (mi)	320 (200)	1200 (750)	2400 (1500)	2400 (1500)	4800 (3000)
hours	20	75	150	150	300				
5	*	Exhaust system	<ul style="list-style-type: none"> • Check for leakage. • Check for looseness and tighten all screw clamps and joints if necessary. • Replace gasket(s) if necessary. 			√	√	√	
6	*	Air induction system	<ul style="list-style-type: none"> • Check the air cut-off valve, reed valve, and hose for damage. • Replace any damaged parts if necessary. 	√	√	√	√	√	
7		Spark arrester	<ul style="list-style-type: none"> • Clean. 			√	√	√	

General maintenance and lubrication chart

NO.	ITEM	ROUTINE	Whichever comes first ⇒	INITIAL			EVERY		
				month	1	3	6	6	12
				km (mi)	320 (200)	1200 (750)	2400 (1500)	2400 (1500)	4800 (3000)
hours	20	75	150	150	300				
1	*	Cooling system	<ul style="list-style-type: none"> • Check coolant leakage. • Repair if necessary. 	√	√	√	√	√	
				<ul style="list-style-type: none"> • Change coolant. 	Every 2 years				
2		Air filter element	<ul style="list-style-type: none"> • Clean. • Replace if necessary. 	Every 20–40 hours (more often in wet or dusty areas)					
3		Engine oil	<ul style="list-style-type: none"> • Change (warm engine before draining). 	√		√	√	√	
4		Engine oil filter cartridge	<ul style="list-style-type: none"> • Replace. 	√		√		√	
5		Final gear oil/Differential gear oil	<ul style="list-style-type: none"> • Check oil level and for leakage. 	√	√	√	√	√	
			<ul style="list-style-type: none"> • Change. 	√				√	
6	*	Front brake	<ul style="list-style-type: none"> • Check operation/brake pad wear/fluid leakage/see page 8-8. • Correct if necessary. Replace pads if worn to the limit. 	√	√	√	√	√	
7	*	Rear brake	<ul style="list-style-type: none"> • Check operation/brake pad wear/fluid leakage/see page 8-8. • Correct if necessary. Replace pads if worn to the limit. 	√	√	√	√	√	

NO.	ITEM	ROUTINE	Whichever comes first ⇒	INITIAL			EVERY		
				month	1	3	6	6	12
				km (mi)	320 (200)	1200 (750)	2400 (1500)	2400 (1500)	4800 (3000)
				hours	20	75	150	150	300
8	*	Parking brake	• Check operation and adjust if necessary.	√	√	√	√	√	
9	*	Brake fluid	• Change.	Every 2 years					
10	*	Accelerator pedal	• Check operation and free play.	√	√	√	√	√	
11	*	V-belt	• Check operation. • Check for wear, cracks, or damage.	√			√	√	
12	*	Wheels	• Check balance/damage/runout. • Repair if necessary.	√		√	√	√	
13	*	Wheel bearings	• Check bearing assemblies for looseness/damage. • Replace if damaged.	√		√	√	√	
14	*	Front and rear suspension	• Check operation and for oil leakage. • Correct if necessary.			√		√	
15	*	Steering system	• Check operation and for looseness. Replace if damaged. • Check toe-in. Adjust if necessary.	√	√	√	√	√	
16	*	Stabilizer bushes	• Check for cracks or other damage, and replace if necessary.			√	√	√	
17	*	Rear knuckle upper and lower pivots	• Lubricate with lithium-soap-based grease.			√	√	√	

NO.	ITEM	ROUTINE	Whichever comes first ⇒	INITIAL			EVERY		
				month	1	3	6	6	12
				km (mi)	320 (200)	1200 (750)	2400 (1500)	2400 (1500)	4800 (3000)
hours	20	75	150	150	300				
18	* Drive shaft universal joint	• Lubricate with lithium-soap-based grease.				√	√	√	
19	* Engine mount	• Check for cracks or damage. • Check bolt tightness.				√	√	√	
20	* Front and rear axle boots	• Check for cracks or other damage, and replace if necessary.		√				√	
21	* Fittings and fasteners	• Check all chassis fittings and fasteners. • Correct if necessary.		√	√	√	√	√	

TIP

- Some maintenance items need more frequent service if you drive in unusually wet, dusty, sandy or muddy areas, or at full throttle.
- Hydraulic brake service
 - Regularly check and, if necessary, correct the brake fluid level.
 - Every two years replace the internal components of the brake master cylinder and calipers, and change the brake fluid.

- Replace the brake hoses every four years and if cracked or damaged.
-

Hood

To remove

1. Pull the tab on each hood lock up, and then turn the hood locks 1/4 turn clockwise.

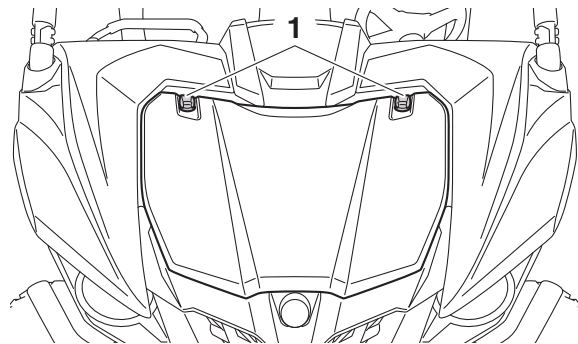

1. Tab

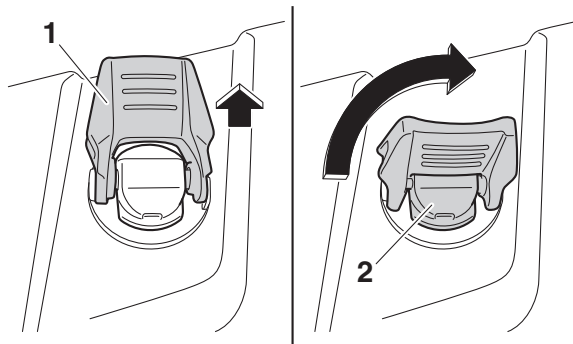

1. Tab
2. Hood lock

2. Remove the hood.

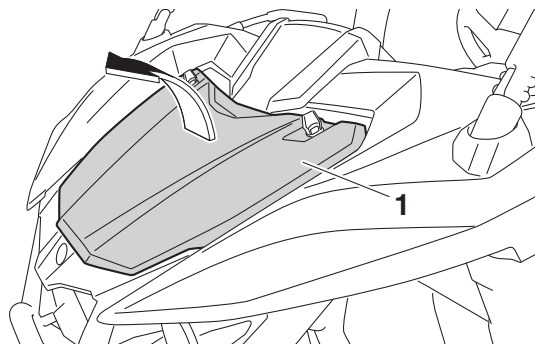

1. Hood

To install

1. Insert the projections on the hood into the slots in the front grill, and then place the hood in the original position.

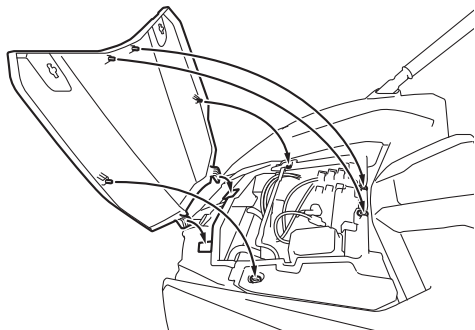

2. Turn the hood locks 1/4 turn counter-clockwise, and then push the tab on each hood lock down so that it is pointing rearward. Make sure that the hood is securely installed.

ECB02180

NOTICE

Do not drive the vehicle with the hood open, unlatched, or removed.

EBU33602

Panels

Left panel

To remove the left panel

1. Remove the bolts.

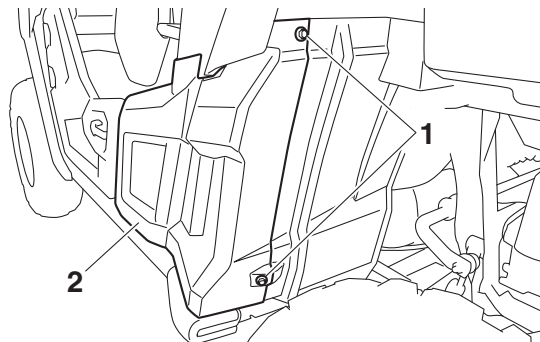

1. Bolt
2. Left panel

2. Open the driver door, and then remove the quick fastener screws.

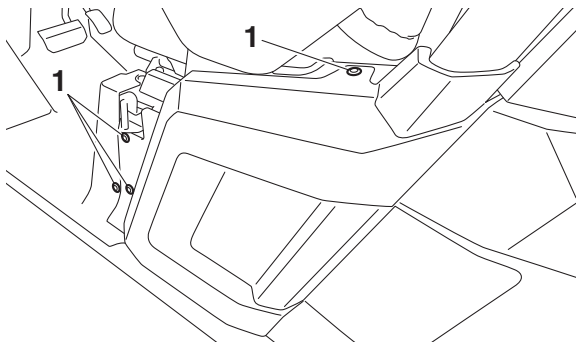

1. Quick fastener screw

3. Pull the panel outward.
4. Close the driver door.

8 To install the left panel

Open the driver door, place the panel in the original position, and then install the bolts and quick fastener screws.

Right panel

To remove the right panel

1. Remove the bolts.

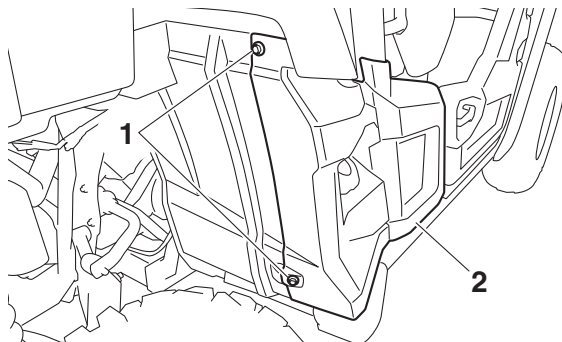

1. Bolt

2. Right panel

2. Open the passenger door, and then remove the quick fastener screws.

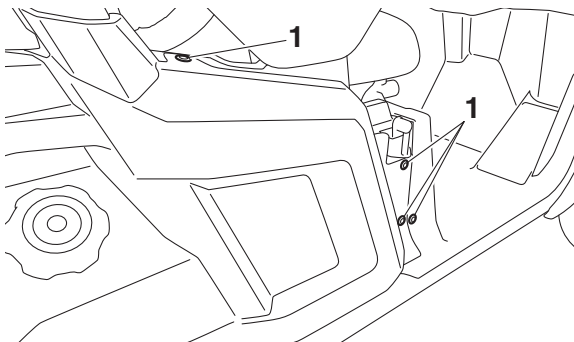

1. Quick fastener screw

3. Remove the fuel tank cap. (See page 4-15.)
4. Pull the panel outward.
5. Install the fuel tank cap.
6. Close the passenger door.

To install the right panel

1. Remove the fuel tank cap.
2. Open the passenger door, place the panel in the original position, and then install the bolts and quick fastener screws.
3. Install the fuel tank cap.

Right rear panel

To remove the right rear panel

1. Remove the right panel.
2. Remove the quick fastener screws, and then take the panel off.

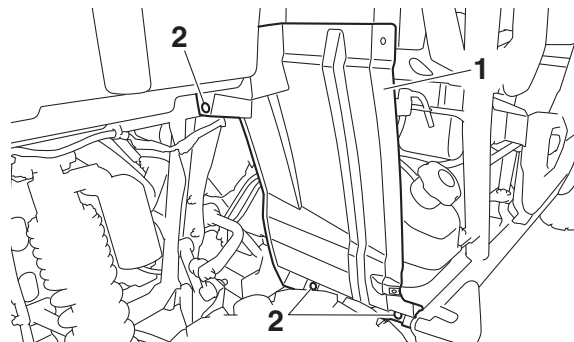

1. Right rear panel
2. Quick fastener screw

To install the right rear panel

1. Place the panel in the original position, and then install the quick fastener screws.
2. Install the right panel.

Engine oil and oil filter cartridge

Check engine oil level before each operation. In addition, change the oil and the oil filter cartridge at the intervals specified in the periodic maintenance and lubrication chart.

To check the engine oil level

1. Park the vehicle on a level surface.
2. Check the engine oil level on a cold engine.

TIP

If the engine was started before checking the oil level, be sure to warm up the engine sufficiently, and then wait at least 10 minutes until the oil settles for an accurate reading.

8

3. Remove the passenger seat cushion (see page 4-15 for more information).
4. Remove the rubber cover.

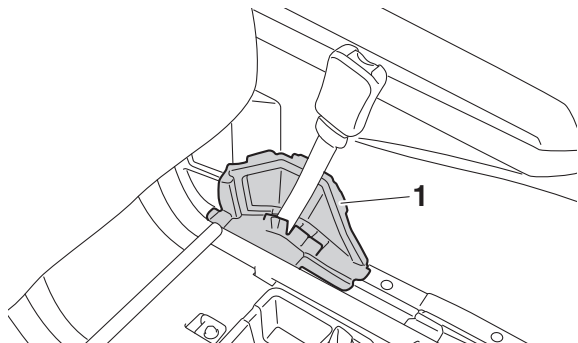

1. Rubber cover

5. Remove the engine oil dipstick and wipe it with a clean rag.

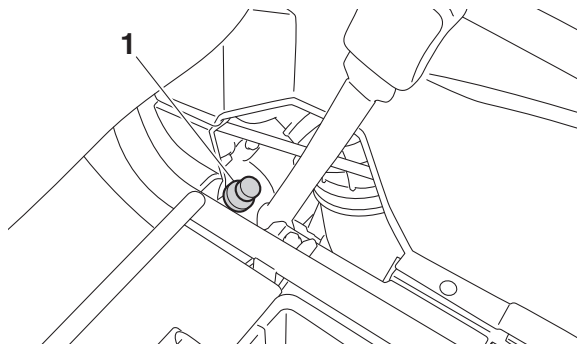

1. Engine oil dipstick

6. With the arrow mark pointing in the direction shown, insert the dipstick completely into the oil filler hole and then remove it again to check the oil level.

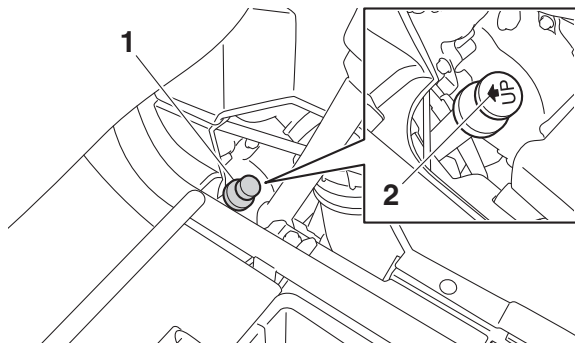

1. Engine oil dipstick
2. Arrow mark

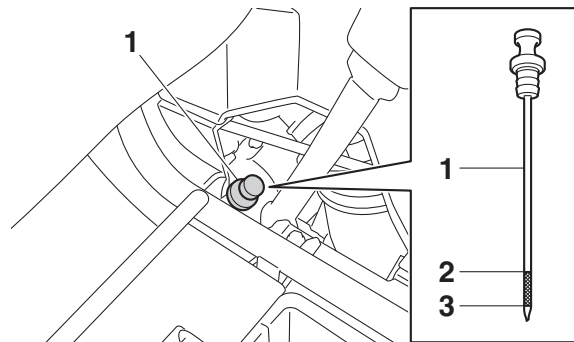

1. Engine oil dipstick
2. Maximum level mark
3. Minimum level mark

TIP

The engine oil should be between the minimum and maximum level marks.

7. If the engine oil is at or below the minimum level mark, add sufficient oil of the recommended type to raise it to the correct level.
8. Install the dipstick with the arrow pointing in the direction shown.

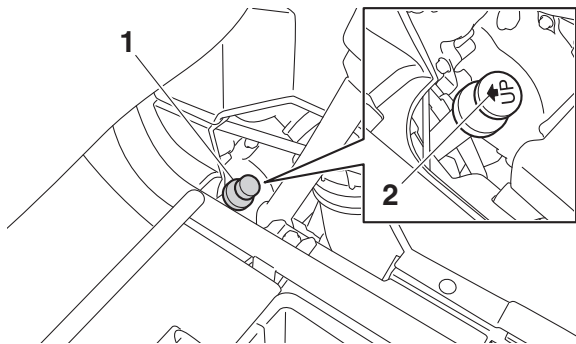

- 1. Engine oil dipstick
- 2. Arrow mark

- 9. Install the rubber cover.
- 10. Install the passenger seat cushion.

8

To change the engine oil (with or without oil filter cartridge replacement)

- 1. Park the vehicle on a level surface.
- 2. Start the engine, warm it up for several minutes, and then turn it off.
- 3. Remove the passenger seat cushion (see page 4-15 for more information).
- 4. Remove the rubber cover.

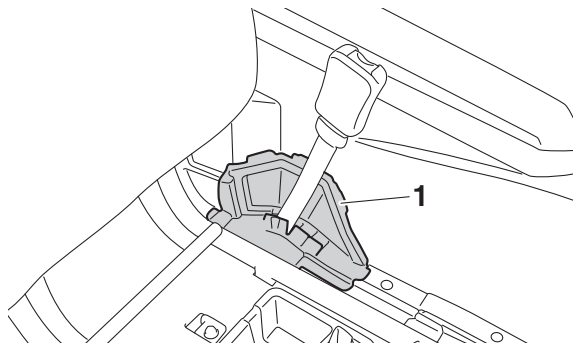

- 1. Rubber cover

- 5. Remove the engine oil dipstick.
- 6. Place an oil pan under the engine to collect the used oil.
- 7. Remove the engine oil drain bolt and its gasket to drain the oil from the crankcase.

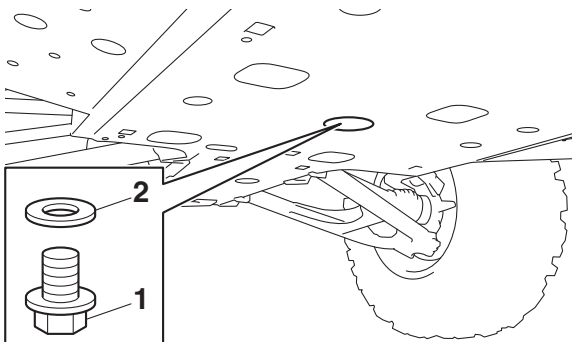

1. Engine oil drain bolt
2. Gasket

TIP

Skip steps 8–10 if the oil filter cartridge is not being replaced.

8. Remove the oil filter cartridge with an oil filter wrench. Make sure that the O-ring is removed together with the oil filter cartridge. If the O-ring remains attached to the crankcase, oil leakage may occur.

TIP

An oil filter wrench is available from a Yamaha dealer.

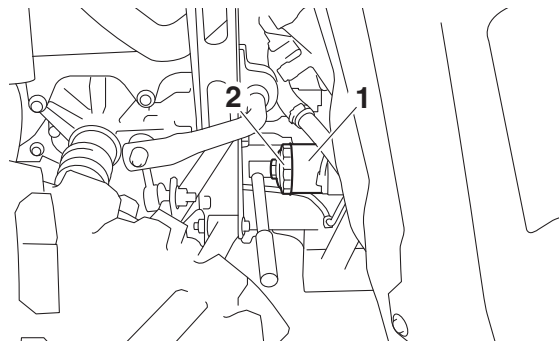

1. Oil filter cartridge
2. Oil filter wrench

9. Apply a light coat of clean engine oil to the O-ring of the new oil filter cartridge.

TIP

Make sure that the O-ring is properly seated.

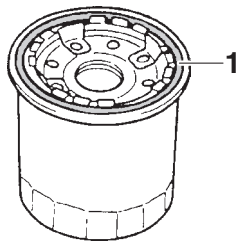

1. O-ring

10. Install the new oil filter cartridge with an oil filter wrench, and then tighten it to the specified torque with a torque wrench.

8

Tightening torque:

Oil filter cartridge:

15 N·m (1.5 kgf·m, 11 lb·ft)

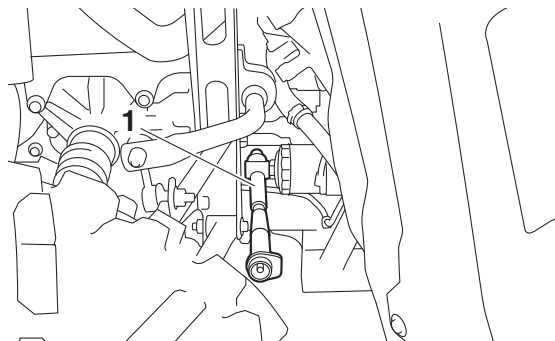

1. Torque wrench

11. Install the engine oil drain bolt and its new gasket, and then tighten the bolt to the specified torque.

Tightening torque:

Engine oil drain bolt:

22 N·m (2.2 kgf·m, 16 lb·ft)

12. Refill with the specified amount of recommended engine oil into the oil filler hole.
13. Install the dipstick with the arrow pointing in the direction shown.

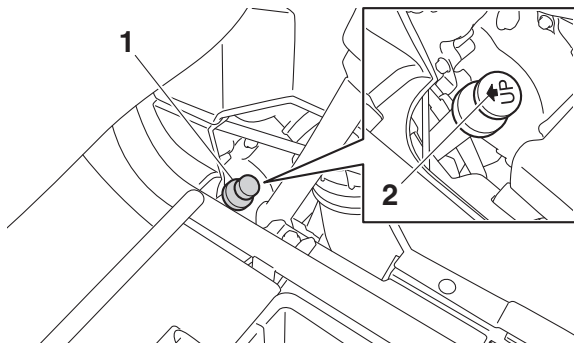

1. Engine oil dipstick
2. Arrow mark

Recommended engine oil:

See page 10-1.

Oil quantity:

Without oil filter cartridge replacement:

2.20 L (2.33 US qt, 1.94 Imp.qt)

With oil filter cartridge replacement:

2.30 L (2.43 US qt, 2.02 Imp.qt)

TIP

Be sure to wipe off spilled oil on any parts after the engine and exhaust system have cooled down.

ECB00301

NOTICE

- In order to prevent clutch slippage (since the engine oil also lubricates the clutch), do not mix any chemical additives. Do not use oils with a diesel specification of “CD” or oils of a higher quality than specified. In addition, do not use oils labeled “ENERGY CONSERVING II” or higher.
- Make sure that no foreign material enters the crankcase.

14. Start the engine, and then let it idle for several minutes while checking it for oil leakage. If oil is leaking, immediately turn the engine off and check for the cause.

15. Turn the engine off, wait at least 10 minutes, and then check the oil level and correct it if necessary.
16. Install the rubber cover.
17. Install the passenger seat cushion.

EBU36050

Final gear oil

Check the oil level and change the final gear oil at the intervals specified in the general maintenance and lubrication chart.

Checking the final gear oil level

1. Park the vehicle on a level surface.
2. Remove the final gear oil filler bolt and its gasket, and then check the oil level in the final gear case. The oil level should be at the brim of the filler hole.

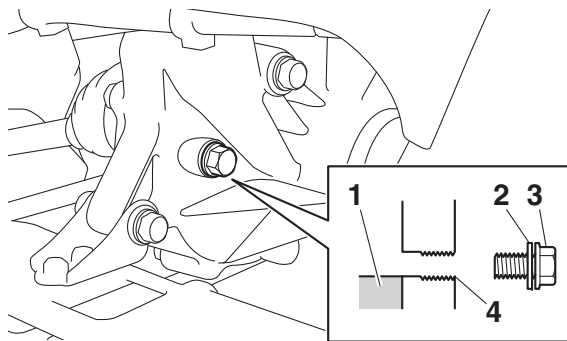

1. Final gear oil
2. Gasket
3. Final gear oil filler bolt
4. Correct oil level

3. If the oil is below the brim of the filler hole, add sufficient oil of the recommended type to raise it to the correct level.
NOTICE: Be sure no foreign material enters the final gear case. [ECB00422]
4. Check the gasket for damage, and replace it if necessary.
5. Install the oil filler bolt and its gasket, and then tighten the bolt to the specified torque.

Tightening torque:

Final gear oil filler bolt:

23 N·m (2.3 kgf·m, 17 lb·ft)

Changing the final gear oil

1. Park the vehicle on a level surface.
2. Place an oil pan under the final gear case to collect the used oil.
3. Remove the final gear oil filler bolt, the final gear oil drain bolt and their gasket to drain the oil.

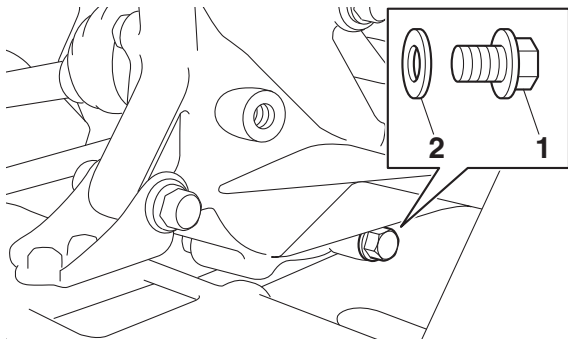

1. Final gear oil drain bolt
2. Gasket

4. Install the drain bolt and its new gasket, and then tighten the bolt to the specified torque.

Tightening torque:

Final gear oil drain bolt:

22 N·m (2.2 kgf·m, 16 lb·ft)

5. Refill with the recommended final gear oil up to the brim of the filler hole. **NOTICE:** Be sure no foreign material enters the final gear case. [ECB00422]

Recommended oil:

SAE 80 API GL-4 Hypoid gear oil

Oil quantity:

0.64 L (0.68 US qt, 0.56 Imp.qt)

TIP

- GL-4 is a quality and additive rating; GL-5 rated hypoid gear oils may also be used.
- If desired, an SAE 80W-90 hypoid gear oil may be used instead.

6. Check the oil filler bolt gasket for damage, and replace it if necessary.
7. Install the oil filler bolt and its gasket, and then tighten the bolt to the specified torque.

Tightening torque:

Final gear oil filler bolt:

23 N·m (2.3 kgf·m, 17 lb·ft)

8. Check for oil leakage. If oil leakage is found, check for the cause.

EBU36060

8 Differential gear oil

Check the oil level and change the differential gear oil at the intervals specified in the general maintenance and lubrication chart.

Checking the differential gear oil level

1. Park the vehicle on a level surface.

2. Remove the differential gear oil filler bolt and its gasket, and then check the oil level. It should be up to the brim of the filler hole.

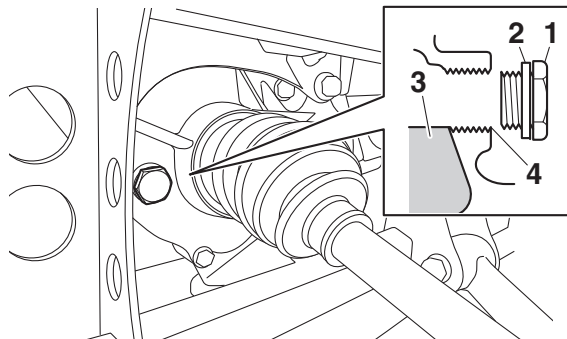

1. Differential gear oil filler bolt
2. Gasket
3. Differential gear oil
4. Correct oil level

3. If the level is low, add sufficient oil of the recommended type to raise it to the specified level. **NOTICE: Be sure no foreign material enters the differential gear case.** [ECB00412]

4. Check the gasket for damage, and replace it if necessary.
5. Install the differential gear oil filler bolt and its gasket, and then tighten the bolt to the specified torque.

Tightening torque:

Differential gear oil filler bolt:
23 N·m (2.3 kgf·m, 17 lb·ft)

Changing the differential gear oil

1. Park the vehicle on a level surface.
2. Place an oil pan under the differential gear case to collect the used oil.
3. Remove the differential gear oil filler bolt, the differential gear oil drain bolt and their gasket to drain the oil.

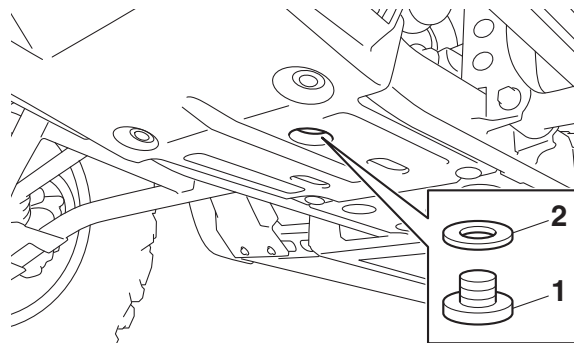

1. Differential gear oil drain bolt
2. Gasket

4. Install the differential gear oil drain bolt and its new gasket, and then tighten the bolt to the specified torque.

Tightening torque:

Differential gear oil drain bolt:
9.8 N·m (0.98 kgf·m, 7.1 lb·ft)

5. Refill the differential gear case with the recommended oil. **NOTICE: Be sure no foreign material enters the differential gear case.** [ECB00412]

Recommended oil:
SAE 80 API GL-4 Hypoid gear oil
Oil quantity:
0.18 L (0.19 US qt, 0.16 Imp.qt)

TIP

- GL-4 is a quality and additive rating; GL-5 rated hypoid gear oils may also be used.
- If desired, an SAE 80W-90 hypoid gear oil may be used instead.

6. Check the oil filler bolt gasket for damage, and replace it if necessary.
7. Install the differential gear oil filler bolt and its gasket, and then tighten the bolt to the specified torque.

Tightening torque:
Differential gear oil filler bolt:
23 N·m (2.3 kgf·m, 17 lb·ft)

8. Check for oil leakage. If oil leakage is found, check for the cause.

EBU33660

Coolant

The coolant level should be checked before each ride. In addition, the coolant must be changed at the intervals specified in the periodic maintenance and lubrication chart.

Checking the coolant level

1. Park the vehicle on a level surface.
2. Check the coolant level in the coolant reservoir when the engine is cold as the coolant level varies with engine temperature.

TIP

The coolant should be between the minimum and maximum level marks.

Changing the coolant

EWB01891

WARNING

Wait for the engine and radiator to cool before removing the radiator cap. You could be burned by hot fluid and steam blown out under pressure. Always place a thick rag over the cap when opening. Allow any remaining pressure to escape before completely removing the cap.

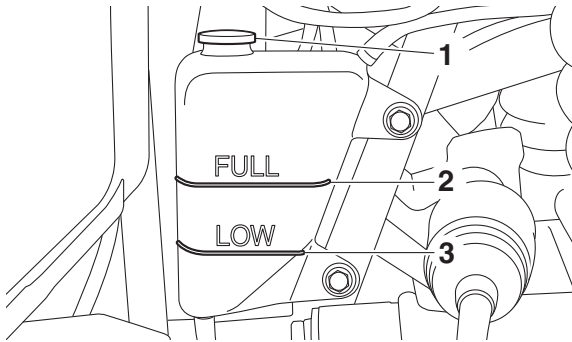

1. Coolant reservoir cap
2. Maximum level mark
3. Minimum level mark

3. If the coolant is at or below the minimum level mark, remove the coolant reservoir cap, add coolant to the maximum level mark, and install the reservoir cap.

Coolant reservoir capacity (up to the maximum level mark):

0.28 L (0.30 US qt, 0.25 Imp.qt)

1. Park the vehicle on a level surface.
2. Remove the hood. (See page 8-10 for hood removal and installation procedures.)
3. Place a container under the engine to collect the used coolant.
4. Remove the radiator cap.

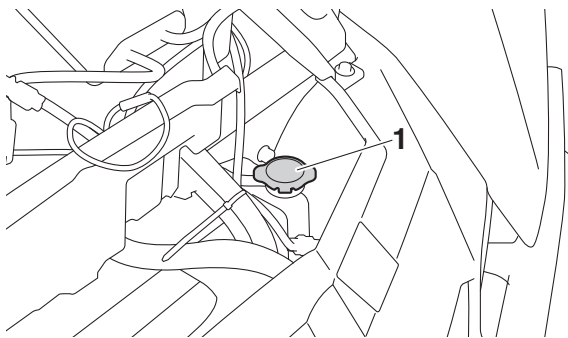

1. Radiator cap

5. Remove the coolant drain bolt and its gasket to drain the coolant from the engine and radiator.

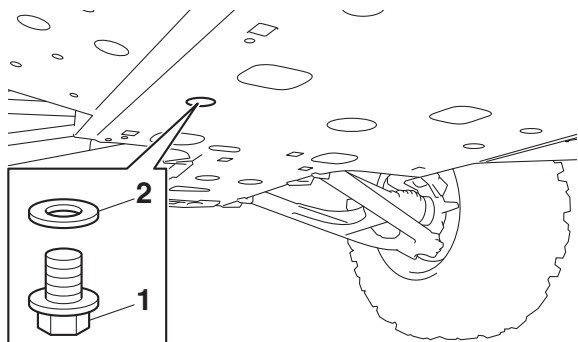

1. Coolant drain bolt

2. Gasket

6. Place a container under the coolant reservoir to collect the used coolant.
7. Remove the coolant reservoir cap.

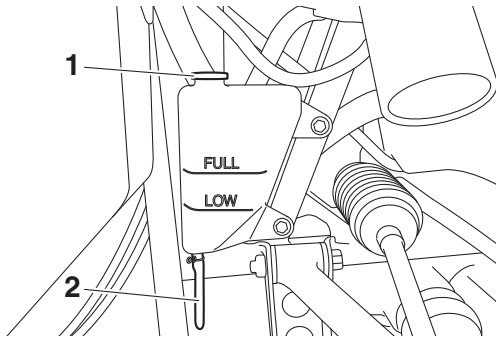

1. Coolant reservoir cap
2. Coolant reservoir hose

8. Disconnect the coolant reservoir hose, and then drain the coolant from the coolant reservoir.
9. After draining the coolant, thoroughly flush the cooling system with clean tap water.
10. Install the coolant drain bolt and its new gasket and then tighten the bolt to the specified torque.

Tightening torque:

Coolant drain bolt:

8 N·m (0.8 kgf·m, 5.8 lb·ft)

11. Connect the coolant reservoir hose.
12. Pour the recommended coolant into the radiator until it is full.
13. Pour the recommended coolant into the reservoir to the maximum level mark, and then install the reservoir cap.

ECB02190

NOTICE

Mix antifreeze with distilled water only. However, if distilled water is not available, soft water may be used for refilling. Do not use hard water or salt water since they are harmful to the engine.

Antifreeze/water mixture ratio:

1:1

Recommended antifreeze:

High-quality ethylene glycol antifreeze containing corrosion inhibitors for aluminum engines

Coolant quantity:

Radiator (including all routes):

2.85 L (3.01 US qt, 2.51 Imp.qt)

Coolant reservoir (up to the maximum level mark):

0.28 L (0.30 US qt, 0.25 Imp.qt)

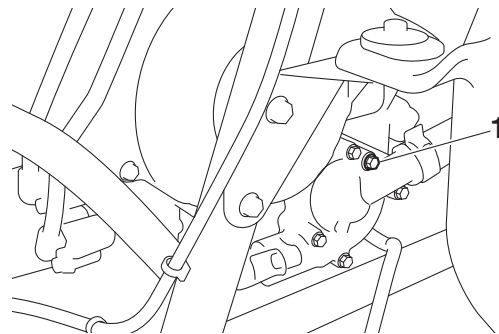

1. Water pump air bleed bolt

16. When coolant begins to flow out of the bolt hole, tighten the water pump air bleed bolt to the specified torque.

Tightening torque:

Water pump air bleed bolt:

8 N·m (0.8 kgf·m, 5.8 lb·ft)

17. Loosen the cylinder head air bleed bolt, without removing it, to allow all of the air to escape from the air bleed bolt hole.

14. Remove the right panel and right rear panel. (See page 8-11 for right panel and right rear panel removal and installation procedures.)
15. Loosen the water pump air bleed bolt, without removing it, to allow all of the air to escape from the air bleed bolt hole.

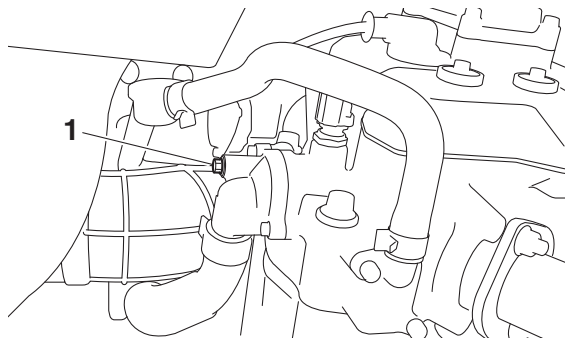

1. Cylinder head air bleed bolt

18. When coolant begins to flow out of the bolt hole, tighten the cylinder head air bleed bolt to the specified torque.

Tightening torque:

Cylinder head air bleed bolt:
10 N·m (1.0 kgf·m, 7.2 lb·ft)

19. Start the engine and let it idle for ten minutes.
20. Rev the engine five times.
21. Pour additional coolant into the radiator until it is full.

22. Stop the engine and allow it to cool. If the coolant level has dropped after the engine has cooled, add sufficient coolant until it reaches the top of the radiator, and then install the radiator cap.
23. Check the coolant level in the reservoir. If necessary, remove the coolant reservoir cap, add coolant to the maximum level mark, and then install the cap.
24. Start the engine, and then check for coolant leakage.

TIP _____

If any leakage is found, have a Yamaha dealer check the cooling system.

25. Install the panels and the hood.

EBU32400

Axle boots

Check the axle boots for holes or tears.

If any damage is found, have them replaced by a Yamaha dealer.

Spark plug inspection

Removal

1. Remove the spark plug cap.

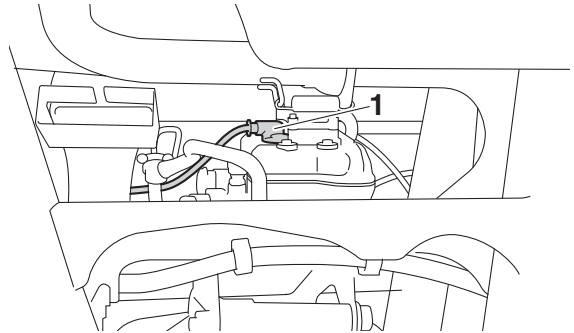

1. Spark plug cap
2. Use the spark plug wrench in the tool kit to remove the spark plug as shown.

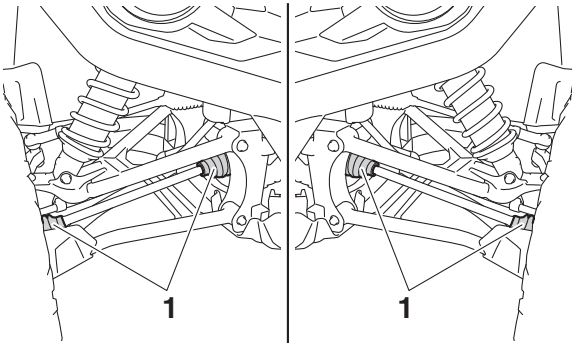

1. Front axle boot

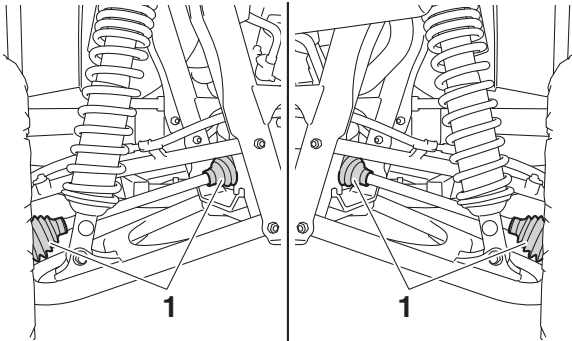

1. Rear axle boot

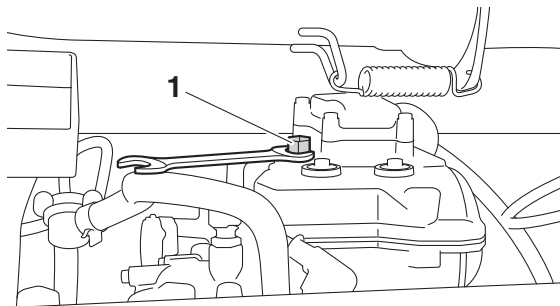

1. Spark plug wrench

Inspection

The spark plug is an important engine component and is easy to inspect. The condition of the spark plug can indicate the condition of the engine.

The ideal color of the porcelain insulator around the center electrode is a medium-to-light tan for a vehicle that is being ridden normally.

You should periodically remove and inspect the spark plug because heat and deposits will cause the spark plug to slowly break down

and erode. If electrode erosion becomes excessive, or if carbon and other deposits are excessive, you should replace the spark plug with the specified plug.

Specified spark plug:
NGK/CPR7EA-9

Measure the spark plug gap with a wire thickness gauge and, if necessary, adjust the gap to specification.

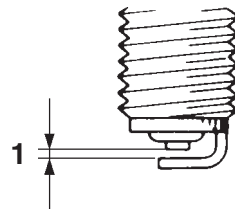

1. Spark plug gap

Spark plug gap:
0.8–0.9 mm (0.031–0.035 in)

Installation

1. Clean the surface of the spark plug gasket and its mating surface, and then wipe off any grime from the spark plug threads.
2. Install the spark plug and tighten it to the specified torque. If a torque wrench is not available when you are installing the spark plug, a good estimate of the correct torque is one-quarter to one-half turn past finger tight. Have the spark plug tightened to the specified torque as soon as possible.

Tightening torque:
Spark plug:
11 N·m (1.1 kgf·m, 8.0 lb·ft)

3. Install the spark plug cap.

EBU33580

Cleaning the air filter element

The air filter element should be cleaned every 20–40 hours. It should be cleaned and lubricated more often if the vehicle is operated in extremely dusty areas. Each time air filter element maintenance is performed, check the air inlet to the air filter case for obstructions.

Check the air filter element rubber joint to the throttle body and manifold fittings for an airtight seal. Tighten all fittings securely to avoid the possibility of unfiltered air entering the engine.

ECB02270

NOTICE

Never operate the engine with the air filter element removed. Doing so would allow unfiltered air to enter, causing rapid engine wear and possible engine damage. Additionally, the fuel injection system would be affected, resulting in poor engine performance and possible overheating.

1. Remove the storage compartment located between the driver seat and the passenger seat as shown.

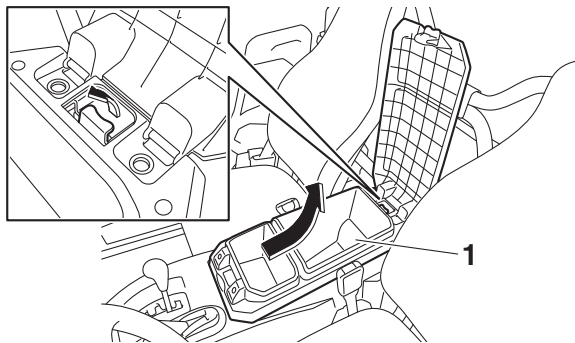

1. Storage compartment

2. Remove the air filter case cover by unhooking the holders.

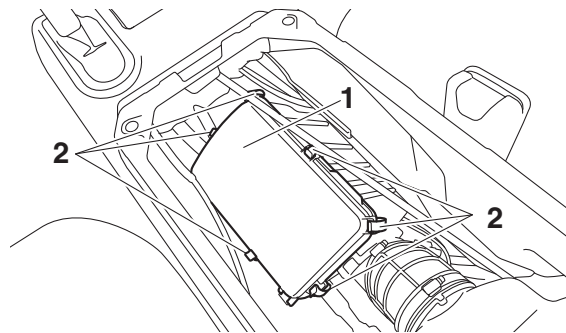

1. Air filter case cover

2. Air filter case cover holder

3. Remove the air filter element.

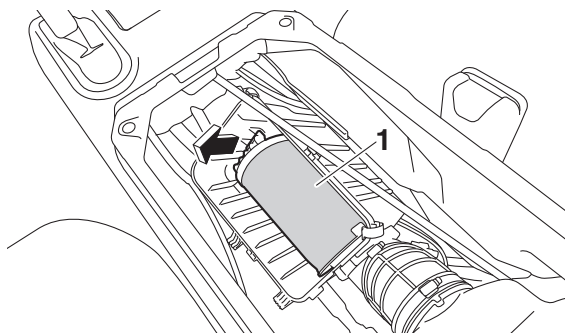

1. Air filter element

4. While pushing the projections on the air filter frame inward, remove the air filter element holder.

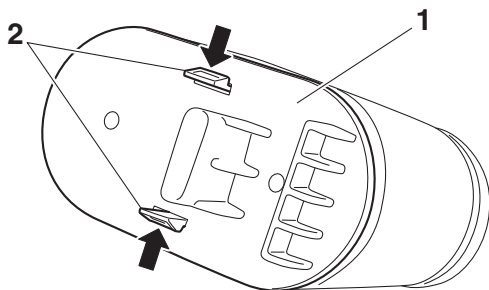

1. Air filter element holder
2. Projection

5. Remove the sponge material from the air filter frame.

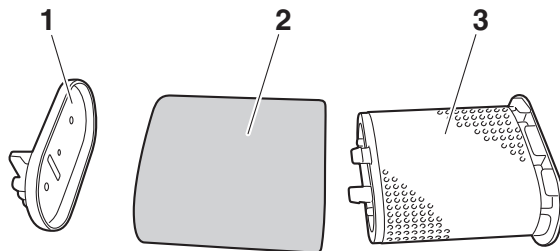

1. Air filter element holder
2. Sponge material
3. Air filter frame

6. Wash the sponge material gently but thoroughly in parts cleaning solvent. **WARNING! Using gasoline or other flammable solvents to clean the air filter element can cause a fire or explosion, which could lead to serious injury.** [EWB03360]
7. Squeeze the excess solvent out of the sponge material. **NOTICE: Do not twist the sponge material when squeezing it.** [ECB00442]

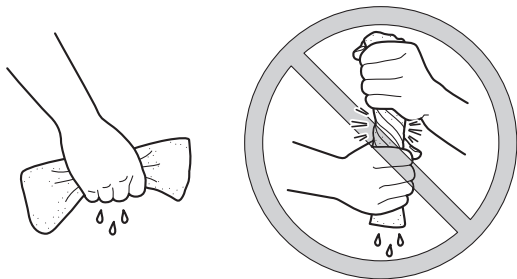

8. Wash the sponge material in warm soapy water to remove remaining solvent, then rinse thoroughly with plain warm water.
 9. Squeeze excess water out of the sponge material. **NOTICE: Do not twist the sponge material when squeezing it.**
- [ECB00442]
10. Allow the sponge material to dry thoroughly. Inspect the sponge material and replace it if damaged.

11. Thoroughly apply Yamaha foam air filter oil or other quality liquid foam air filter oil (not spray type) to the sponge material. The sponge material should be wet but not dripping.
12. Pull the sponge material over its frame.
13. Install the air filter element holder.
14. Install the air filter element.
15. Fit the holders on the air filter case cover onto the projections on the air filter case, and then install the air filter case cover by hooking the holders onto the cover.

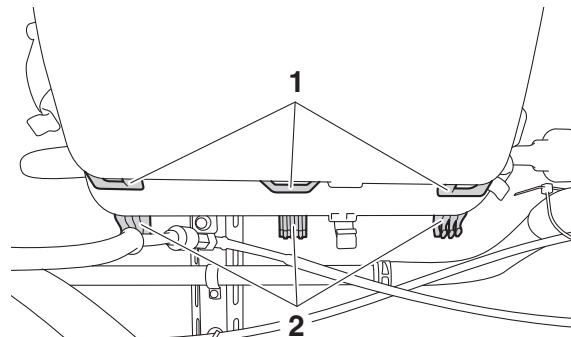

1. Holder
2. Projection

16. Install the storage compartment as shown.

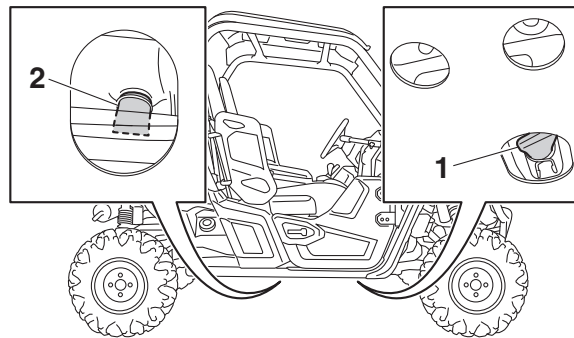
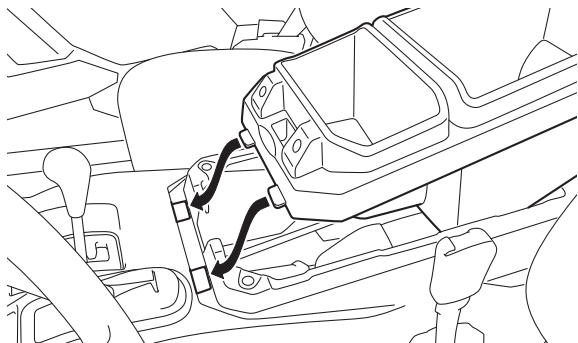

1. Air duct check hose
2. Air filter case check hose

EBU33672

8

Cleaning the air filter case/air duct check hose

There is a check hose at the bottom of the air filter case and at the bottom of the air duct. The check hoses can be accessed under the vehicle. If dust or water collects in a check hose, empty the hose and clean the air filter element and air filter case.

EBU33691

V-belt case drain plug

The V-belt case drain plug is located behind the left panel. (See page 8-11 for left panel removal and installation procedures.)

After operating in water deep enough to allow water to enter the V-belt case, remove the drain plug to drain any water from the case.

If water drains from the V-belt case after removing the drain plug, have a Yamaha dealer inspect the vehicle, as the water may affect other engine parts.

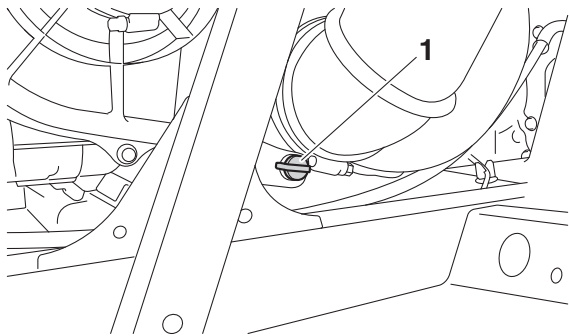

1. V-belt case drain plug

EBU32450

Cleaning the spark arrester

EWB03370



WARNING

Hot exhaust system may cause burns. To avoid burns or fires, make sure that the engine is stopped and the exhaust system is cool before cleaning the spark arrester. Do not start the engine while cleaning the exhaust system.

1. Remove the tailpipe bolts.

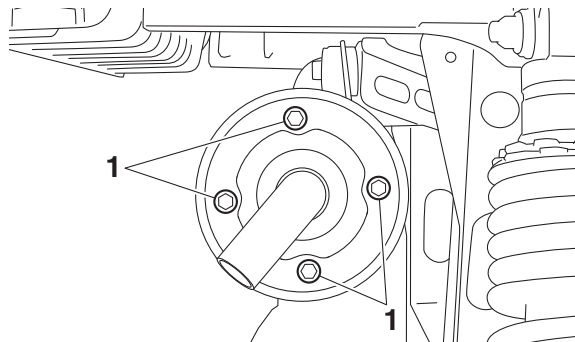

1. Tailpipe bolt

2. Remove the tailpipe by pulling it out of the muffler, and then remove the gasket.
3. Tap the tailpipe lightly, and then use a wire brush to remove any carbon deposits from the spark arrester portion of the tailpipe and inside of the tailpipe housing.

Valve clearance

The correct valve clearance changes with use, resulting in improper fuel/air supply or engine noise. To prevent this, the valve clearance must be adjusted regularly. This adjustment however, should be left to a professional Yamaha service technician.

Brakes

Replacement of brake components requires professional knowledge. Brake service should be performed by a Yamaha dealer.

⚠ WARNING

Operating with improperly serviced or adjusted brakes could lead to a loss in braking ability and an accident.

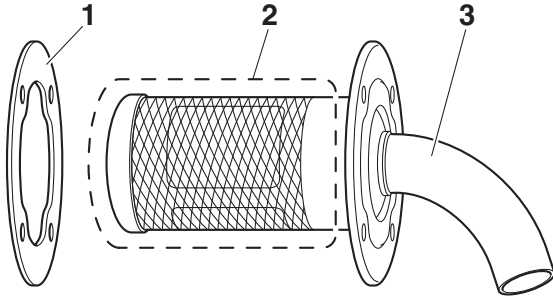

1. Gasket
2. Spark arrester
3. Tailpipe

8

4. Install the gasket, and then insert the tailpipe into the muffler and align the bolt holes.
5. Install the bolts and tighten them to the specified torque.

Tightening torque:

Tailpipe bolt:

10 N·m (1.0 kgf·m, 7.2 lb·ft)

Checking the front and rear brake pads

Each brake pad is provided with wear indicator grooves, which allow you to check the brake pad wear without having to disassemble the brake. To check the brake pad wear, check the wear indicator grooves. If a brake pad has worn to the point that the wear indicator grooves have almost disappeared, have a Yamaha dealer replace the brake pads as a set.

The wheels need to be removed to check the brake pads. (See pages 8-45, 8-46 for wheel removal and installation procedures.)

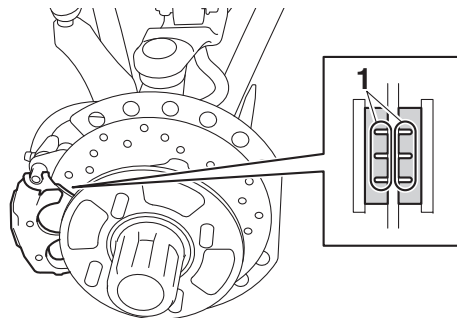

1. Brake pad wear indicator groove

Checking the brake fluid level

Before starting off, check that the brake fluid is above the minimum level mark. Check the brake fluid level with the top of the reservoir level. Replenish the brake fluid if necessary.

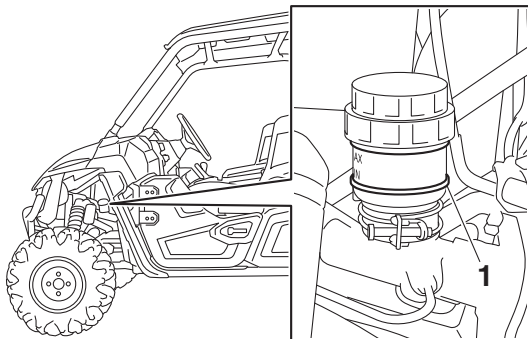

1. Minimum level mark

Specified brake fluid: DOT 4

8

EWB02721

WARNING

Improper maintenance can result in loss of braking ability. Observe these precautions:

- Insufficient brake fluid may allow air to enter the brake system, reducing braking performance.

- Clean the filler cap before removing. Use only DOT 4 brake fluid from a sealed container.
- Use only the specified brake fluid; otherwise, the rubber seals may deteriorate, causing leakage.
- Refill with the same type of brake fluid. Adding a brake fluid other than DOT 4 may result in a harmful chemical reaction.
- Be careful that water does not enter the brake fluid reservoir when refilling. Water will significantly lower the boiling point of the fluid and may result in vapor lock.

ECB01161

NOTICE

Brake fluid may damage painted surfaces or plastic parts. Always clean up spilled fluid immediately.

As the brake pads wear, it is normal for the brake fluid level to gradually go down. A low brake fluid level may indicate worn brake pads and/or brake system leakage; therefore, be sure to check the brake pads for wear and the brake system for leakage. If the brake fluid level goes down suddenly, have a Yamaha dealer check and repair the vehicle before any further operation.

EBU32520

Brake fluid replacement

Complete fluid replacement should be done only by trained Yamaha service personnel. Have a Yamaha dealer replace the following components during periodic maintenance or when they are damaged or leaking.

- Replace the oil seals every two years.
- Replace the brake hoses every four years.

EBU32530

Checking the brake pedal

Have a Yamaha dealer check the brakes at the intervals specified in the periodic maintenance and lubrication chart. There should be no free play in the brake pedal. The brakes should operate smoothly and there should be no brake drag. If the brakes feel soft or spongy, this could indicate air in the brake system. Have a Yamaha dealer check the brake system if necessary.

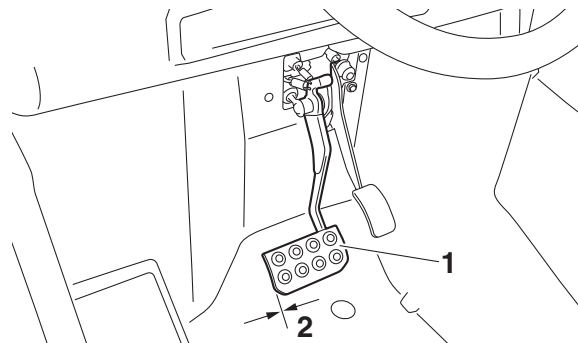

1. Brake pedal
2. No brake pedal free play

Parking brake

Pull the parking brake lever rearward completely. If the parking brake lever clicks eight times or more, have a Yamaha dealer adjust the parking brake because the braking force of the parking brake is weak. In addition, have a Yamaha dealer check and adjust the parking brake at the intervals specified in the periodic maintenance and lubrication chart.

Brake light switch adjustment

The brake light switch, which is activated by the brake pedal, is properly adjusted when the brake light comes on just before braking takes effect. If necessary, adjust the brake light switch as follows.

Turn the adjusting nut while holding the brake light switch in place. To make the brake light come on earlier, turn the adjusting nut in direction (a). To make the brake light come on later, turn the adjusting nut in direction (b).

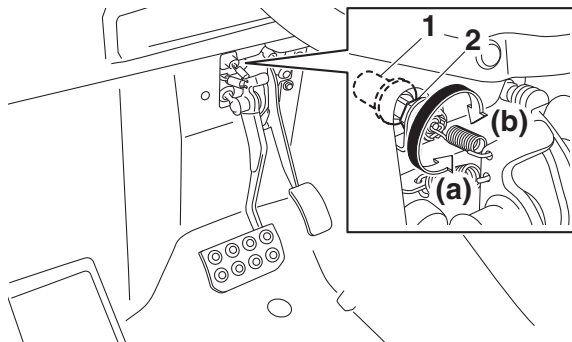

1. Brake light switch
2. Adjusting nut

Cable inspection and lubrication

⚠ WARNING

Damaged cables could restrict operation, which may cause an accident or injury. Inspect control cables frequently and replace damaged cables. Corrosion can result when the outer covering of control cables becomes damaged. Cables can also become frayed or kinked.

Lubricate the cable ends. If the cables do not operate smoothly, ask a Yamaha dealer to replace them.

Recommended lubricant:
Yamalube LubezAll (synthetic lubricant
spray with PTFE)

EBU32570

Brake pedal and accelerator pedal lubrication

Lubricate the pivoting parts.

Recommended lubricant:
Lithium-soap-based grease

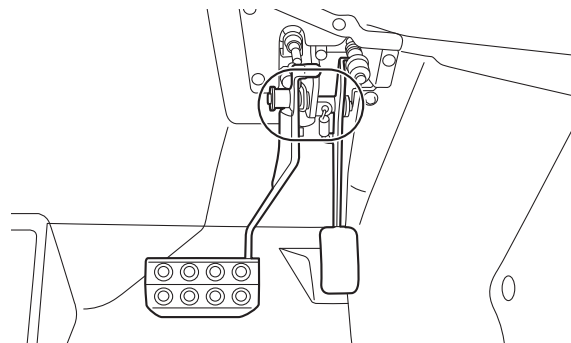

EBU32582

Checking the stabilizer bushes

The stabilizer bushes must be checked for cracks or damage at the intervals specified in the periodic maintenance and lubrication chart.

Have a Yamaha dealer replace the stabilizer bushes if necessary.

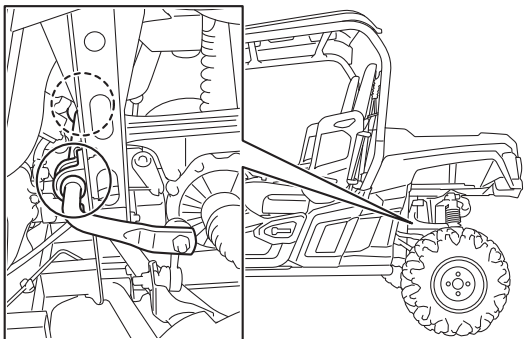

EBU32590

Rear knuckle upper and lower pivot lubrication (left and right)

8

Lubricate the knuckle upper and lower pivots with a grease gun.

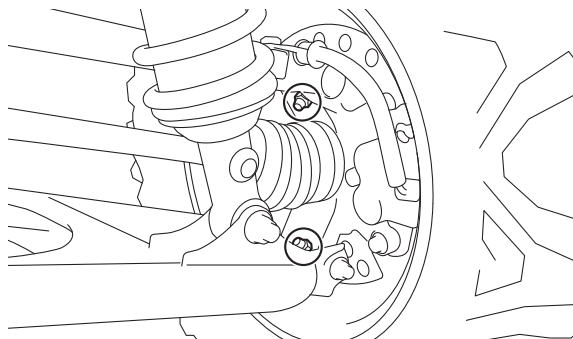

Recommended lubricant:
Lithium-soap-based grease

EBU32600

Steering shaft lubrication

Lubricate the pivot points.

Recommended lubricant:
Lithium-soap-based grease

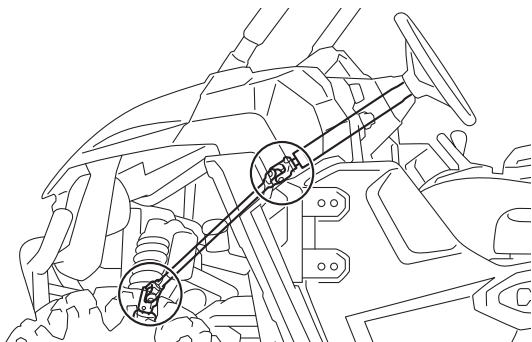

EBU32610

Wheel removal

1. Loosen the wheel nuts.
2. Elevate the vehicle and place a suitable stand under the frame.
3. Remove the nuts from the wheel.
4. Remove the wheel.

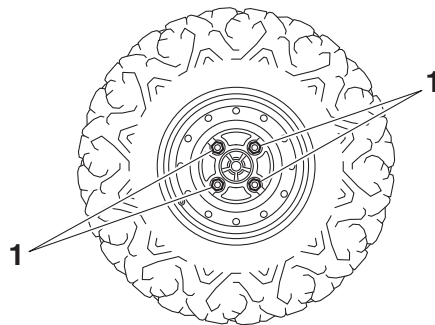

1. Wheel nut

EBU32620

Tire replacement

Always use the same size and type of tires recommended in this owner's manual. The tires that came with your Yamaha Wolverine were designed to match the performance capabilities and to provide the best combination of handling, braking, and comfort. It is best to replace all four tires at the same time. If that is not possible, you must replace the tires in

pairs (front or rear) with tires of the same size and type as the originals. Never replace just one tire.

EWB03390

⚠ WARNING

Installing improper tires on your Yamaha Wolverine can affect handling and stability. This can cause a loss of control.

The tires listed below have been approved by Yamaha Motor Manufacturing Corporation of America for this model.

8

Front tire:

Size:

26 x 8-12NHS

Manufacturer/model:

MAXXIS/MU09

Rear tire:

Size:

26 x 10-12NHS

Manufacturer/model:

MAXXIS/MU10

EBU33030

Wheel installation

1. Install the wheel and the nuts.

TIP

For YXE70WPXH / YXE70WPHH: tapered nuts are used for both the front and rear wheels. Install the nuts with their tapered side towards the wheel.

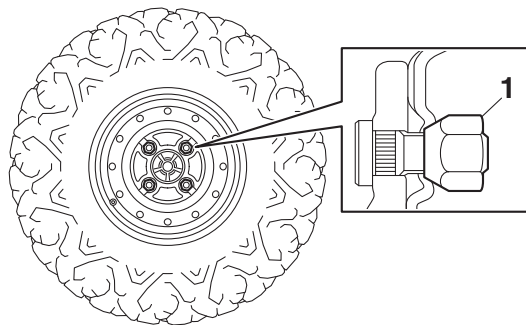

1. Tapered nut
2. Lower the vehicle so that the wheel is on the ground.
3. Tighten the wheel nuts in a crisscross pattern to the specified torque.



Do not reverse the rims on your Yamaha Wolverine to widen the track width. Installing wheels improperly increases the risk of wheel failure and accidents.

Tightening torques:

Front wheel nut:

75 N·m (7.5 kgf·m, 54 lb·ft)

Rear wheel nut:

75 N·m (7.5 kgf·m, 54 lb·ft)

Battery

The battery is located under the hood. (See page 8-10 for hood removal and installation procedures.)

This model is equipped with a VRLA (Valve Regulated Lead Acid) battery. There is no need to check the electrolyte or to add distilled water. However, the battery lead connections need to be checked and, if necessary, tightened.



Avoid battery contact with skin, eyes, or clothing. Shield eyes when working near batteries. Keep out of reach of children. You could be poisoned or severely burned by the sulfuric acid in battery electrolyte. In case of accidental contact with battery electrolyte:

EXTERNAL: Flush with water.

INTERNAL: Drink large quantities of water or milk. Follow with milk of magnesia, beaten egg, or vegetable oil. Get prompt medical attention.

EYES: Flush with water for 15 minutes and get prompt medical attention.

⚠ WARNING

Batteries may produce explosive gases. Ventilate when charging or using in a closed space. Keep batteries away from sparks, flames, cigarettes, or other sources of ignition.

To remove the battery

1. Turn the key to “○” (off).
2. Remove the hood. (See page 8-10 for hood removal and installation procedures.)
3. Remove the air intake duct panel by removing the quick fastener screws.

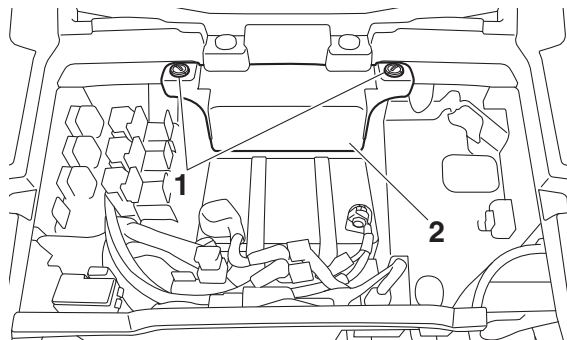

1. Quick fastener screw
2. Air intake duct panel

4. Unhook the battery bands.
5. Disconnect the negative battery lead first, then the positive battery lead by removing their bolt. **NOTICE: When removing the battery, the main switch must be off, and the negative lead must be disconnected before the positive lead.**

[ECB01002]

NOTICE

To charge a VRLA (Valve Regulated Lead Acid) battery, a special (constant-voltage) battery charger is required. Using a conventional battery charger will damage the battery.

To store the battery

- If the vehicle will not be used for more than one month, remove the battery, fully charge it, and then place it in a cool, dry place.
- If the battery will be stored for more than two months, check it at least once a month and fully charge it if necessary.

NOTICE

Always keep the battery charged. Storing a discharged battery can cause permanent battery damage.

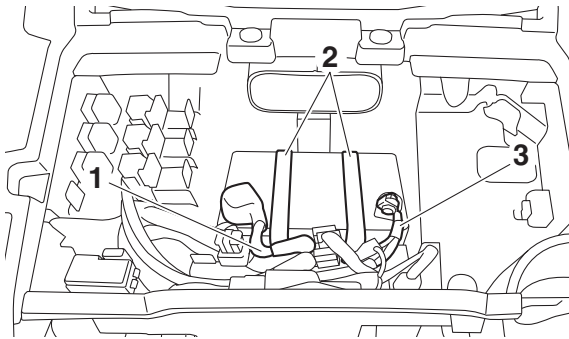

1. Positive battery lead (red)
2. Battery band
3. Negative battery lead (black)

6. Pull the battery out of its compartment.

To charge the battery

Have a Yamaha dealer charge the battery as soon as possible if it seems to have discharged. Keep in mind that the battery tends to discharge more quickly if the vehicle is equipped with optional electrical accessories.

To install the battery

TIP

Be sure the battery is fully charged.

1. Place the battery in its compartment.
2. Connect the positive battery lead first, then the negative battery lead by installing their bolt. **NOTICE: When installing the battery, the main switch must be off, and the positive lead must be connected before the negative lead.** [ECB01111]

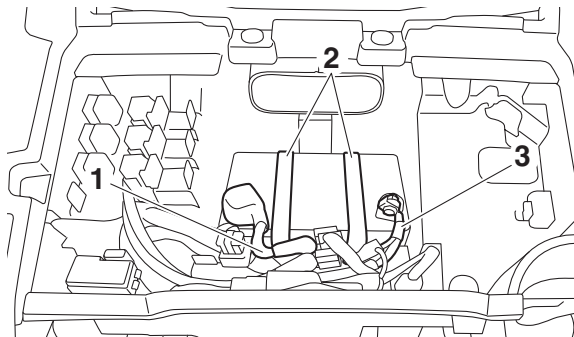

1. Positive battery lead (red)
2. Battery band
3. Negative battery lead (black)

3. Hook the battery bands.
4. Install the air intake duct panel by installing the quick fastener screws.
5. Install the hood.

EBU32650

Jump-starting

Jump-starting the vehicle should be avoided. The battery should be removed and charged instead.



EWB03430

! WARNING

To avoid battery explosion and/or serious damage to the electrical system:

- Do not connect the negative lead of the jumper cable to the negative terminal of the battery.
- Do not touch the positive lead of the jumper cable to the negative lead.
- Do not reverse the polarity of the jumper cables when connecting to the batteries.

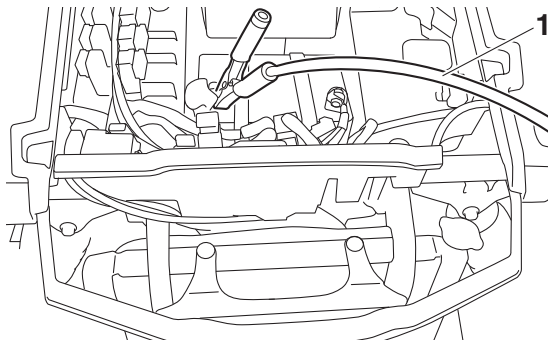
However, if the vehicle must be jump-started, proceed as follows.

1. Turn the key to “A line drawing of a vehicle's engine compartment with the hood removed. A jumper cable is shown with its positive lead (marked with a plus sign) connected to the positive terminal of the vehicle's battery. The other end of the positive lead is connected to the positive terminal of a second, charged battery. A label '1' with a leader line points to the positive lead of the jumper cable.

1. Jumper cable positive lead

4. Connect the negative lead of the jumper cable to the negative terminal of the charged battery and the other end of the negative lead to an unpainted metal surface of the frame of the vehicle to be started.

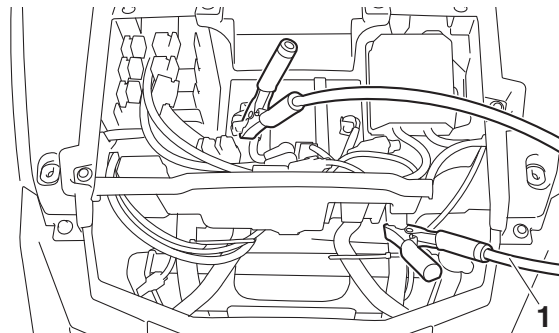

1. Jumper cable negative lead

5. Start the engine. (Refer to “Starting the engine” on page 6-2.)
6. After the engine starts, disconnect the negative lead of the jumper cable from the frame and charged battery, and then

disconnect the positive lead of the jumper cable from the charged battery and the battery in the vehicle.

7. Install the hood.

EBU33100

Fuse replacement

The main fuse, the fuel injection system fuse, the EPS fuse, and the fuse box are located under the hood. (See page 8-10 for hood removal and installation procedures.)

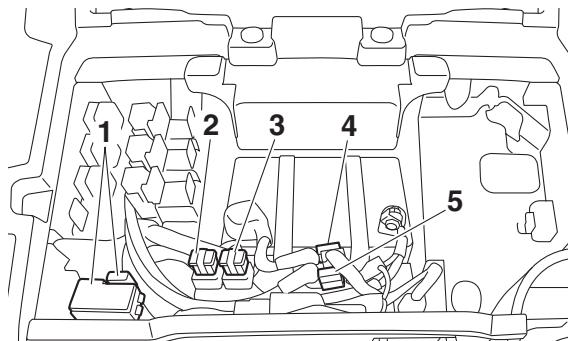

1. Fuse box
2. Main fuse
3. EPS fuse
4. Fuel injection system fuse
5. Fuel injection system spare fuse

NOTICE

To prevent accidental short-circuiting, turn off the main switch when checking or replacing a fuse.

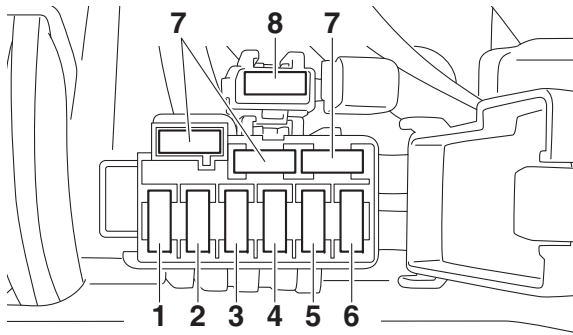

1. Backup fuse "BACK UP" (for clock)
2. Ignition fuse "IGNITION"
3. Four-wheel-drive motor fuse "DIFF"
4. Auxiliary DC jack fuse "TERMINAL"
5. Signaling system fuse "SIGNAL"
6. Headlight fuse "HEAD"
7. Spare fuse
8. Radiator fan motor fuse "FAN"

If a fuse is blown, replace it as follows.

1. Turn the key to "○" (off) and turn off the electrical circuit in question.

2. Remove the hood. (See page 8-10 for hood removal and installation procedures.)

3. Remove the blown fuse, and then install a new fuse of the specified amperage.

WARNING! Always use a fuse of the specified amperage. Never use any material in place of the proper fuse. Using an improper fuse can cause damage to the electrical system and may lead to a fire. [EWB03440]

Specified fuses:**Main fuse:**

40.0 A

Fuel injection system fuse:

10.0 A

Headlight fuse:

15.0 A

Ignition fuse:

10.0 A

Auxiliary DC jack fuse:

10.0 A

Signaling system fuse:

10.0 A

Four-wheel-drive motor fuse:

10.0 A

Radiator fan motor fuse:

25.0 A

Backup fuse:

10.0 A

EPS fuse:

40.0 A

4. Turn the key to “ I ” (on) and turn on the electrical circuit in question to check if the device operates. If the fuse blows again immediately, have a Yamaha dealer check the electrical system.
5. Install the hood.

EBU32670

Replacing a headlight bulb

If a headlight bulb burns out, replace it as follows.

1. Remove the cover at the rear of the headlight by pulling it off.

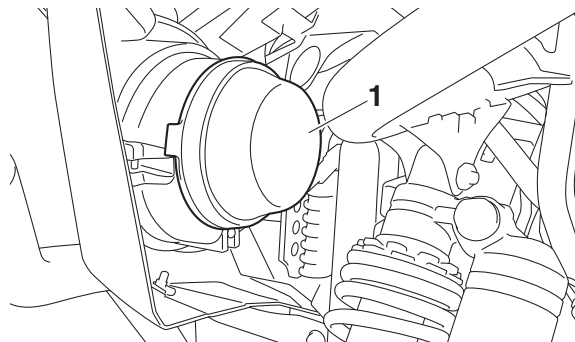

1. Cover at the rear of the headlight

2. Remove the headlight bulb cover by pulling it off.

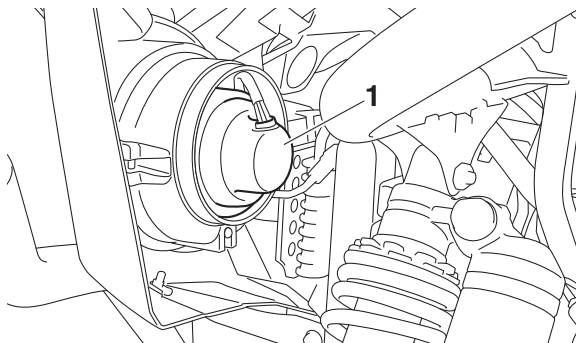

1. Headlight bulb cover

3. Disconnect the headlight coupler.

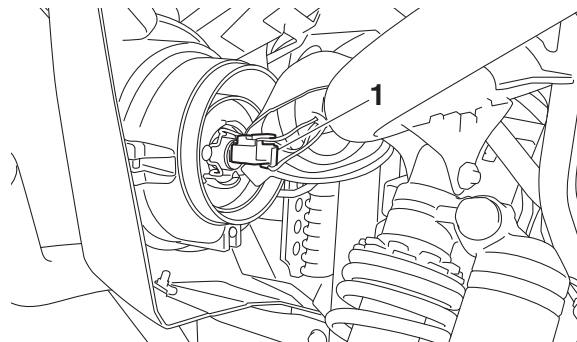

1. Headlight coupler

4. Unhook the headlight bulb holder.

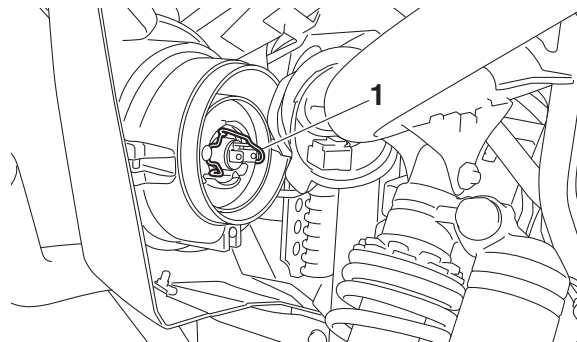

1. Headlight bulb holder

5. Wait for the headlight bulb to cool before touching or removing it. Remove the burnt-out bulb by pulling it out.
6. Place a new headlight bulb into position, and then secure it with the bulb holder.
NOTICE: Do not touch the glass part of the headlight bulb to keep it free from oil, otherwise the transparency of the glass, the luminosity of the bulb, and the bulb life will be adversely affected. Thoroughly clean off any dirt and fingerprints on the headlight bulb using a cloth moistened with alcohol or thinner. [ECB00652]

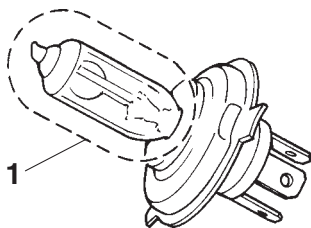

1. Do not touch the glass part of the bulb.
7. Connect the headlight coupler.
8. Install the bulb cover and the cover at the rear of the headlight. **NOTICE:** Make sure the headlight bulb cover is securely fitted over the bulb holder and seated properly. [ECB02210]
9. Adjust the headlight beam if necessary.

Headlight beam adjustment

NOTICE

It is advisable to have a Yamaha dealer make this adjustment.

To raise the beam, turn the headlight beam adjusting screw in direction (a).

To lower the beam, turn the headlight beam adjusting screw in direction (b).

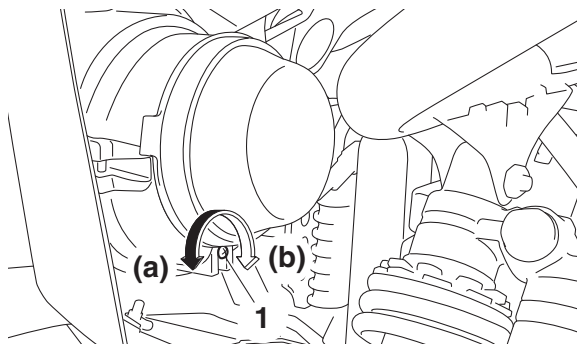

1. Headlight beam adjusting screw

Tail/brake light bulb replacement

If a tail/brake light bulb burns out, replace it as follows:

1. Remove the tail/brake light bulb holder (together with the bulb) by turning it counterclockwise.

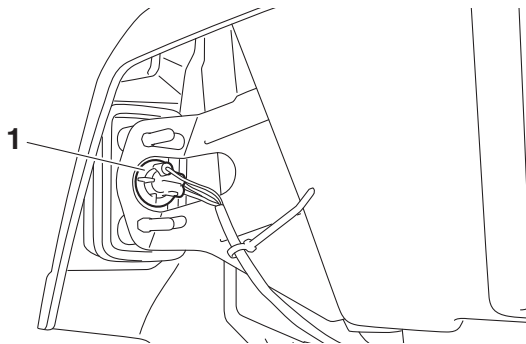

1. Tail/brake light bulb holder
2. Push the burnt-out bulb in and turn it counterclockwise to remove it from the bulb holder.
3. Push a new bulb in and turn it clockwise to install in the bulb holder.

4. Install the bulb holder (together with the bulb) by turning it clockwise.

EBU32700

Troubleshooting

Although Yamaha vehicles receive an inspection before shipment from the factory, trouble may occur during operation. Any problem in the fuel, compression, or ignition systems can cause poor starting and loss of power. The troubleshooting chart describes a quick, easy procedure for making checks. If your vehicle requires any repair, take it to a Yamaha dealer.

8

The skilled technicians at a Yamaha dealership have the tools, experience, and know-how to properly service your vehicle. Use only genuine Yamaha parts on your vehicle. Imitation parts may look like Yamaha parts, but they are often inferior. Consequently, they have a shorter service life and can lead to expensive repair bills.

EWB03450



When checking the fuel system, do not smoke and make sure there are no open flames or sparks in the area, including pilot lights from water heaters or furnaces. Gasoline or gasoline vapors can ignite or explode, causing severe injury or property damage.

Troubleshooting charts

Starting problems or poor engine performance

1. Fuel

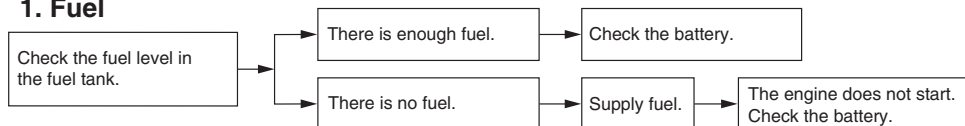

2. Battery

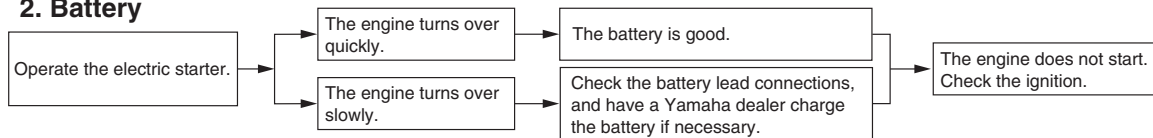

3. Ignition

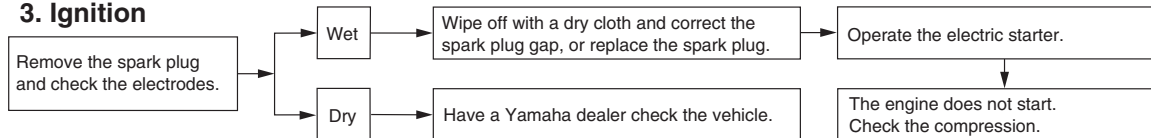

4. Compression

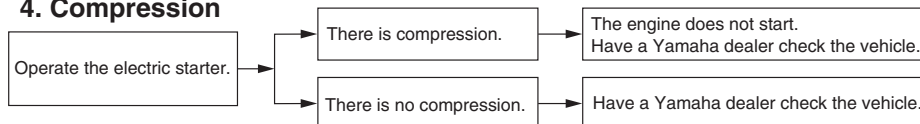

Engine overheating

Wait for the engine to cool before removing the radiator cap. **WARNING! If the engine is not cool when removing the radiator cap, hot fluid and steam could blow out under pressure and burn you.** [EWB03460] Place a thick rag over the cap and remove the cap slowly to allow any remaining pressure to escape.

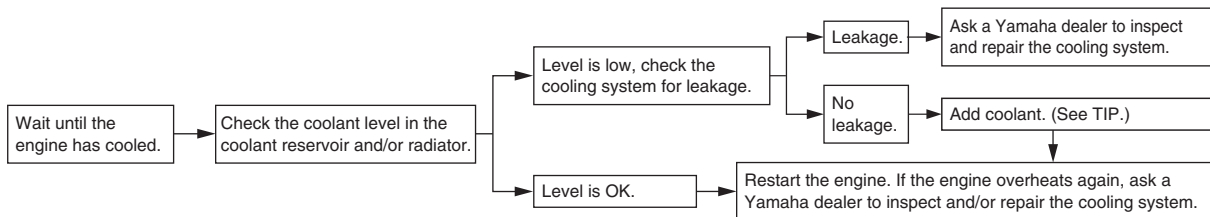

TIP _____
If it is difficult to get the recommended coolant, tap water can be used temporarily, provided that it is changed to the recommended coolant as soon as possible.

CLEANING AND STORAGE

Cleaning

Frequent, thorough cleaning of your vehicle will not only enhance its appearance but will improve its general performance and extend the useful life of many components.

1. Before cleaning the vehicle:
 - a. Block off the end of the exhaust pipe to prevent water entry. A plastic bag and strong rubber band may be used.
 - b. Make sure the spark plug and all filler caps are properly installed.
2. If the engine case is excessively greasy, apply degreaser with a paint brush. Do not apply degreaser to the wheel axles.
3. Rinse the dirt and degreaser off with a garden hose. Use only enough pressure to do the job. **WARNING! Test the brakes after washing. Apply the brakes several times at slow speeds to let friction dry the brakes. Wet brakes**

may have reduced stopping ability, increasing the chance of an accident.

[EWB03471] **NOTICE: Excessive water pressure may cause water seepage and deterioration of wheel bearings, brakes, transmission seals and electrical devices. Many expensive repair bills have resulted from improper high-pressure detergent applications such as those available in coin-operated car washers.** [ECB00712]

TIP

The tailgate can be removed to make it easier to clean the cargo bed. To separate the tailgate from the cargo bed, unhook the latches, and then pull up the tailgate. (See page 4-21 for tailgate removal and installation procedures.)

4. Once the majority of the dirt has been hosed off, wash all surfaces with warm water and mild, detergent-type soap. An old toothbrush or bottle brush is handy for hard-to-get-at places.
5. Rinse the vehicle off immediately with clean water and dry all surfaces with a clean chamois towel or soft, absorbent cloth.
6. Clean the seats with a vinyl upholstery cleaner to keep the covers pliable and glossy.
7. Automotive-type wax may be applied to all painted and chrome-plated surfaces. Avoid combination cleaner-waxes. Many contain abrasives which may scratch the paint or protective finish. When finished, start the engine and let it idle for several minutes.

EBU36120

Storage

Long term storage (60 days or more) of your vehicle will require some preventive procedures to guard against deterioration. Make any necessary repairs before storing the vehicle.

After thoroughly cleaning the vehicle, prepare for storage as follows:

1. Fill the fuel tank with fresh fuel and add the specified amount of Fuel Med Rx or another high-quality fuel stabilizer product. Follow the instructions on the product label. Operate the vehicle for at least 5 minutes to distribute treated fuel through the fuel system.

Specified amount:

1 oz of stabilizer to each gallon of fuel (or
7.5 ml of stabilizer to each liter of fuel)

2. Remove the spark plug and pour one tablespoon of fresh engine oil into the cylinder and then re-install the spark plug.

Remove the spark plug wire and ground it. Operate the electric starter to turn the engine over several times and coat the cylinder walls with oil.

3. Lubricate all control cables.
4. Put the frame on stands or blocks to raise all wheels off the ground.
5. Tie a plastic bag over the exhaust pipe outlet to prevent moisture from entering.
6. If storing in a humid or salt-air atmosphere, coat all exposed metal surfaces with a light film of oil. Do not apply oil to any rubber parts or the seat covers.
7. Remove the battery and charge it. Store it in a dry place and recharge it once a month. Do not store the battery in an excessively warm or cold place [less than 0 °C (30 °F) or more than 30 °C (90 °F)].

Use of fuel stabilizer eliminates the need to drain the fuel system. Consult a Yamaha dealer if the fuel system needs to be drained.

SPECIFICATIONS

Dimensions:

- Overall length:
2970 mm (116.9 in)
- Overall width:
1540 mm (60.6 in)
- Overall height:
1885 mm (74.2 in)
- Wheelbase:
2065 mm (81.3 in)
- Ground clearance:
290 mm (11.4 in)
- Minimum turning radius:
4600 mm (181 in)

Weight:

- Curb weight:
595.0 kg (1312 lb)

Noise and vibration level:

- Noise level (77/311/EEC):
80.0 dB(A) at 3125 r/min (YXE70WPAH, YXE70WPXH)
- Uncertainty of measurement:
3.0 dB(A) (YXE70WPAH, YXE70WPXH)
- Vibration on seat (EN1032, ISO5008):
Will not exceed 0.5 m/s² (YXE70WPAH, YXE70WPXH)
- Uncertainty of measurement:
0.0 m/s² (YXE70WPAH, YXE70WPXH)
- Vibration on handle (EN1032, ISO5008):
Will not exceed 2.5 m/s² (YXE70WPAH, YXE70WPXH)

Uncertainty of measurement:

0.5 m/s² (YXE70WPAH, YXE70WPXH)

Engine:

- Engine type:
Liquid cooled 4-stroke, DOHC
- Cylinder arrangement:
Single cylinder
- Displacement:
708 cm³
- Bore × stroke:
103.0 × 85.0 mm (4.06 × 3.35 in)
- Compression ratio:
10.1 : 1
- Starting system:
Electric starter
- Lubrication system:
Wet sump

Engine oil:

- Recommended brand:
YAMALUBE

Type:

SAE 0W-30, 10W-30, 10W-40, 15W-40, 20W-40 or 20W-50

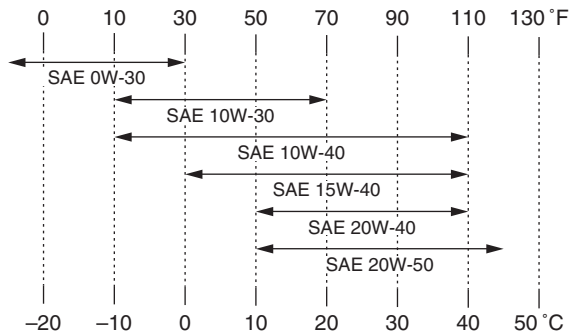

Recommended engine oil grade:

API service SG type or higher, JASO standard MA

Engine oil quantity:

Without oil filter cartridge replacement:

2.20 L (2.33 US qt, 1.94 Imp.qt)

With oil filter cartridge replacement:

2.30 L (2.43 US qt, 2.02 Imp.qt)

Final gear oil:

Type:

SAE 80 API GL-4 Hypoid gear oil

Quantity:

0.64 L (0.68 US qt, 0.56 Imp.qt)

Differential gear oil:

Type:

SAE 80 API GL-4 Hypoid gear oil

Quantity:

0.18 L (0.19 US qt, 0.16 Imp.qt)

Coolant quantity:

Coolant reservoir (up to the maximum level mark):

0.28 L (0.30 US qt, 0.25 Imp.qt)

Radiator (including all routes):

2.85 L (3.01 US qt, 2.51 Imp.qt)

Air filter:

Air filter element:

Wet element

Fuel:

Recommended fuel:

Regular unleaded gasoline only

Fuel tank capacity:

36.7 L (9.69 US gal, 8.07 Imp.gal)

Fuel injection:

Throttle body:

ID mark:

2MB1 00

Spark plug (s):

Manufacturer/model:

NGK/CPR7EA-9

Spark plug gap:

0.8–0.9 mm (0.031–0.035 in)

Clutch:

Clutch type:

Wet, centrifugal automatic

Transmission:

Secondary reduction system:

Shaft drive

Secondary reduction ratio:
43/21 × 17/12 × 33/9 (10.636)

Transmission type:
V-belt automatic

Operation:
Right hand operation
Reverse gear:
23/14 × 28/23 (2.000)

Low range:
31/16 (1.938)

High range:
30/22 (1.364)

Chassis:

Frame type:
Steel tube frame
Caster angle:
3.70 °

Trail:
19.0 mm (0.75 in)

Front tire:

Type:
Tubeless

Size:
26 x 8-12NHS

Manufacturer/model:
MAXXIS/MU09

Rear tire:

Type:
Tubeless

Size:
26 x 10-12NHS

Manufacturer/model:
MAXXIS/MU10

Loading:

Maximum loading limit:
327.0 kg (721 lb)
(Total weight of operator, passengers, cargo, accessories,
and tongue)

Tire air pressure (measured on cold tires):

Recommended:

Vehicle load:
0 - maximum

Front:
75.0 kPa (0.750 kgf/cm², 11 psi)

Rear:
75.0 kPa (0.750 kgf/cm², 11 psi)

Minimum:

Vehicle load:
0 - maximum

Front:
70.0 kPa (0.700 kgf/cm², 10 psi)

Rear:
70.0 kPa (0.700 kgf/cm², 10 psi)

Front wheel:

Wheel type:
Cast wheel (YXE70WPAH)
Panel wheel (YXE70WPHH, YXE70WPXH)

Rim size:
12 x 6.0AT

Rear wheel:

Wheel type:

Cast wheel (YXE70WPAH)

Panel wheel (YXE70WPHH, YXE70WPXH)

Rim size:

12 x 7.5AT

Front brake:

Type:

Hydraulic disc brake

Operation:

Unified brake

Specified brake fluid:

DOT 4

Rear brake:

Type:

Hydraulic disc brake

Operation:

Unified brake

Specified brake fluid:

DOT 4

Front suspension:

Type:

Double wishbone

Spring/shock absorber type:

Coil spring/gas-oil damper

Wheel travel:

246 mm (9.7 in)

Rear suspension:

Type:

Double wishbone

Spring/shock absorber type:

Coil spring/gas-oil damper

Wheel travel:

269 mm (10.6 in)

Electrical system:

Ignition system:

TCI

Charging system:

AC magneto

Battery:

Model:

U1-H11L

Voltage, capacity:

12 V, 28.0 Ah

Headlight(s):

Bulb type:

Halogen bulb

Bulb voltage, wattage × quantity:

Headlight:

12 V, 35.0/35.0 W × 2

Tail/brake light:

12 V, 5.0/21.0 W × 2

Neutral indicator light:

LED

Reverse indicator light:

LED

Coolant temperature warning light:

LED

Engine trouble warning light:

LED

Parking brake indicator light:

LED

On-Command four-wheel-drive/differential gear lock indicator:

LCD

High-range indicator light:

LED

Low-range indicator light:

LED

Differential gear lock indicator light:

LED

EPS warning light:

LED

Helmet/Seat belt indicator light:

14 V, 0.85 W × 2

Four-wheel-drive motor fuse:

10.0 A

Radiator fan motor fuse:

25.0 A

EBU33221

For Europe only

The figures quoted are emission levels and are not necessarily safe working levels. Whilst there is a correlation between the emission and exposure levels, this cannot be used reliably to determine whether or not further precautions are required. Factors that influence the actual level of exposure of work-force include the characteristics of the work room, the other sources of noise, etc. i.e. the number of machines and other adjacent processes, and the length of time for which an operator is exposed to the noise. Also the permissible exposure level can vary from country. This information, however, will enable the user of the machine to make a better evaluation of the hazard and risk.

Fuses:

Main fuse:

40.0 A

Fuel injection system fuse:

10.0 A

EPS fuse:

40.0 A

Headlight fuse:

15.0 A

Signaling system fuse:

10.0 A

Ignition fuse:

10.0 A

Auxiliary DC jack fuse:

10.0 A

Backup fuse:

10.0 A

CONSUMER INFORMATION

EBU33320

Identification number records

Record the vehicle identification number and model label information in the spaces provided for assistance when ordering spare parts from a Yamaha dealer or for reference, in case the vehicle is stolen.

VEHICLE IDENTIFICATION NUMBER:

MODEL LABEL INFORMATION:

EBU32800

Vehicle identification number

The vehicle identification number is stamped into the frame.

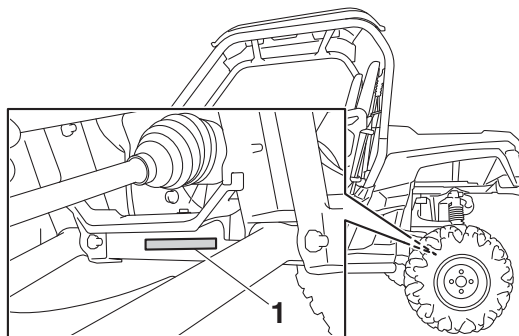

1. Vehicle identification number

The vehicle identification number is used to identify your vehicle.

EBU33331

Model label

The model label can be found under the driver seat. Record the information on this label in the space provided. This information will be needed to order spare parts from your Yamaha dealer.

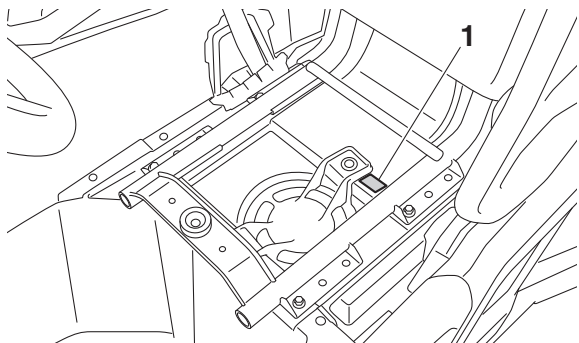

1. Model label

INDEX

A

Accelerator pedal	4-13
Accelerator pedal, Pre-operation check	5-6
Air filter case/air duct check hose, cleaning	8-36
Air filter element, cleaning	8-32
Auxiliary DC jack	4-33
Axle boots	8-29

B

Basic guide for safe use	7-1
Battery, Periodic maintenance	8-47
Brake fluid level, checking	8-39
Brake fluid, replacing	8-41
Brake light switch, adjusting	8-42
Brake pedal	4-13
Brake pedal and accelerator pedal, lubrication	8-43
Brake pedal, checking	8-41
Brakes, Periodic maintenance	8-38
Brakes, Pre-operation check	5-3

C

Cable, inspecting and lubrication	8-42
Cargo bed	4-21
Cleaning	9-1
Control cables, Pre-operation check	5-8
Coolant, Periodic maintenance	8-24
Coolant, Pre-operation check	5-6
Coolant temperature warning light	4-4
Cup holders	4-20

D

Differential gear oil, Periodic maintenance	8-22
---	------

Differential gear, Pre-operation check	5-6
Doors	4-15
Driver seat position	4-16
Drive select lever	4-14
Drive select lever operation and reverse driving	6-3

E

Engine break-in	6-1
Engine oil and oil filter cartridge, Periodic maintenance	8-14
Engine oil, Pre-operation check	5-5
Engine trouble warning light	4-4
EPS warning light	4-5

F

Final gear oil, Periodic maintenance	8-20
Final gear, Pre-operation check	5-6
Fittings and fasteners, Pre-operation check	5-7
Front and rear brake pads, checking	8-39
Fuel, Pre-operation check	5-3
Fuel tank cap	4-15
Fuse, replacing	8-52

G

Glove compartment	4-18
-------------------------	------

H

Headlight beam, adjusting	8-57
Headlight bulb, replacing	8-54
Helmet indicator light	4-5
High-range indicator light	4-2
Hood	8-10
Horn switch	4-12

I

Identification number records	11-1
-------------------------------------	------

Indicator lights and warning lights	4-2
Instruments, lights and switches, Pre-operation check	5-7

J

Jump-starting	8-50
---------------------	------

L

Label locations	1-1
Light switch	4-11
Loading	6-7
Low-range indicator light	4-2

M

Main switch	4-1
Maintenance and lubrication chart	8-6
Maintenance chart, emission control system	8-4
Model label	11-1
Multi-function meter unit	4-6

N

Neutral indicator light	4-3
-------------------------------	-----

O

On-Command drive knob	4-12
On-Command drive knob, operation	6-5
On-Command four-wheel-drive/differential gear lock indicator	4-3
Owner's manual and tool kit	8-2

P

Panels	8-11
Parking	6-7
Parking brake	8-42
Parking brake indicator light	4-3
Parking brake lever	4-13
Passenger handhold, Pre-operation check	5-7

R

Rear knuckle upper and lower pivot, lubrication	8-44
Reverse indicator light	4-3

S

Safety information	2-1
Seat belt indicator light	4-5
Seat belts	4-17
Seat belts, Pre-operation check	5-6
Seats	4-15
Shock absorber assemblies, adjusting the front	4-23
Shock absorber assemblies, adjusting the rear	4-28
Spark arrester, cleaning	8-37
Spark plug, inspecting	8-30
Specifications	10-1
Stabilizer bushes, checking	8-43
Starting the engine	6-2
Steering, Pre-operation check	5-7
Steering shaft, lubrication	8-44
Storage	9-2
Storage compartments	4-19

T

Tail/brake light bulb, replacing	8-57
Tire, replacing	8-45
Tires, Pre-operation check	5-8
Trailer hitch bracket and receiver	4-33
Troubleshooting	8-58
Troubleshooting charts	8-59

V

Valve clearance	8-38
V-belt case drain plug	8-36
Vehicle identification number	11-1

W

Wheel installation 8-46

Wheel removal 8-45

Original instructions



PRINTED IN USA
2016.03-0.3x1 CR
(E)