



OWNER'S MANUAL

MAJESTY

YP125E

5D8-F819D-E0

Welcome to the Yamaha world of motorcycling!

As the owner of the YP125E, you are benefiting from Yamaha's vast experience and newest technology regarding the design and manufacture of high-quality products, which have earned Yamaha a reputation for dependability.

Please take the time to read this manual thoroughly, so as to enjoy all advantages of your YP125E. The owner's manual does not only instruct you in how to operate, inspect and maintain your scooter, but also in how to safeguard yourself and others from trouble and injury.



In addition, the many tips given in this manual will help keep your scooter in the best possible condition. If you have any further questions, do not hesitate to contact your Yamaha dealer.

The Yamaha team wishes you many safe and pleasant rides. So, remember to put safety first!

IMPORTANT MANUAL INFORMATION

EAU34111

Particularly important information is distinguished in this manual by the following notations:

	The Safety Alert Symbol means ATTENTION! BECOME ALERT! YOUR SAFETY IS INVOLVED!
 WARNING	Failure to follow WARNING instructions <u>could result in severe injury or death to the scooter operator, a bystander, or a person inspecting or repairing the scooter.</u>
CAUTION	A CAUTION indicates special precautions that must be taken to avoid damage to the scooter.
NOTE:	A NOTE provides key information to make procedures easier or clearer.

NOTE:

- This manual should be considered a permanent part of this scooter and should remain with it even if the scooter is subsequently sold.
- Yamaha continually seeks advancements in product design and quality. Therefore, while this manual contains the most current product information available at the time of printing, there may be minor discrepancies between your scooter and this manual. If you have any questions concerning this manual, please consult your Yamaha dealer.

EWA12410

WARNING

PLEASE READ THIS MANUAL CAREFULLY AND COMPLETELY BEFORE OPERATING THIS SCOOTER.

*Product and specifications are subject to change without notice.

IMPORTANT MANUAL INFORMATION

EAUS1172

**YP125E
OWNER'S MANUAL
©2006 by YAMAHA MOTOR ESPAÑA S.A.
1st edition, August 2006
All rights reserved.
Any reprinting or unauthorized use
without the written permission of
YAMAHA MOTOR ESPAÑA S.A.
is expressly prohibited.
Printed in Neederland.**

TABLE OF CONTENTS

INTRODUCTION

IMPORTANT MANUAL INFORMATION

TABLE OF CONTENTS

SAFETY INFORMATION1-1

Further safe-riding points1-4

DESCRIPTION.....2-1

Left view2-1

Right view2-2

Controls and instruments2-3

INSTRUMENT AND CONTROL

FUNCTIONS3-1

Main switch/steering lock.....3-1

Indicator lights3-2

Speedometer unit3-2

Battery voltage/fuel gauge3-3

Clock.....3-4

Anti-theft alarm (optional)3-5

Handlebar switches3-5

Front brake lever.....3-6

Rear brake lever.....3-6

Fuel tank cap3-7

Fuel3-8

Fuel tank breather/overflow hose.....3-9

Catalytic converter.....3-9

Seat.....3-9

Front storage compartment.....3-10

Storage compartment.....3-11

Adjusting the shock absorber
assemblies.....3-12

Sidestand.....3-12

Ignition circuit cut-off system3-13

PRE-OPERATION CHECKS4-1

Pre-operation check list.....4-2

OPERATION AND IMPORTANT RIDING

POINTS5-1

Starting a cold engine5-1

Starting off5-2

Acceleration and deceleration5-2

Braking.....5-2

Tips for reducing fuel consumption..5-3

Engine break-in.....5-3

Parking.....5-4

PERIODIC MAINTENANCE AND

MINOR REPAIR.....6-1

Owner's tool kit.....6-1

Periodic maintenance and
lubrication chart6-3

Removing and installing panels.....6-6

Checking the spark plug6-7

Engine oil6-9

Final transmission oil6-11

Coolant6-12

Air filter and V-belt case air filter
elements6-14

Adjusting the carburetor6-15

Adjusting the throttle cable free
play6-15

Valve clearance6-16

Tires6-16

Cast wheels6-18

Front and rear brake lever free
play6-19

Checking the front and rear brake
pads.....6-19

Checking the brake fluid level6-20

Changing the brake fluid6-21

Checking and lubricating
the cables.....6-21

Lubricating the front and rear brake
levers6-22

Checking and lubricating the
centerstand6-22

Checking the front fork.....6-23

Checking the steering.....6-23

Checking the wheel bearings6-24

Battery6-24

Replacing the fuses6-26

Replacing a headlight bulb.....6-27

Replacing a front turn signal
light bulb.....6-29

Replacing the tail/brake light bulb
or a rear turn signal light bulb.....6-30

Replacing the license plate light
bulb6-31

Replacing the auxiliary light bulb ...6-31

TABLE OF CONTENTS

Troubleshooting6-31

Troubleshooting charts6-32

SCOOTER CARE AND STORAGE7-1

Matte color caution.....7-1

Care7-1

Storage7-3

SPECIFICATIONS8-1

CONSUMER INFORMATION9-1

Identification numbers9-1

SAFETY INFORMATION

EAU10261

SCOOTERS ARE SINGLE TRACK VEHICLES. THEIR SAFE USE AND OPERATION ARE DEPENDENT UPON THE USE OF PROPER RIDING TECHNIQUES AS WELL AS THE EXPERTISE OF THE OPERATOR. EVERY OPERATOR SHOULD KNOW THE FOLLOWING REQUIREMENTS BEFORE RIDING THIS SCOOTER.

HE OR SHE SHOULD:

- OBTAIN THOROUGH INSTRUCTIONS FROM A COMPETENT SOURCE ON ALL ASPECTS OF SCOOTER OPERATION.
- OBSERVE THE WARNINGS AND MAINTENANCE REQUIREMENTS IN THE OWNER'S MANUAL.
- OBTAIN QUALIFIED TRAINING IN SAFE AND PROPER RIDING TECHNIQUES.
- OBTAIN PROFESSIONAL TECHNICAL SERVICE AS INDICATED BY THE OWNER'S MANUAL AND/OR WHEN MADE NECESSARY BY MECHANICAL CONDITIONS.

Safe riding

- Always make pre-operation checks. Careful checks may help prevent an accident.
- This scooter is designed to carry the operator and passenger.
- The failure of motorists to detect and recognize scooters in traffic is the predominating cause of automobile/scooter accidents. Many accidents have been caused by an automobile driver who did not see the scooter. Making yourself conspicuous appears to be very effective in reducing the chance of this type of accident.

Therefore:

- Wear a brightly colored jacket.
- Use extra caution when approaching and passing through intersections, since intersections are the most likely places for scooter accidents to occur.
- Ride where other motorists can see you. Avoid riding in another motorist's blind spot.
- Many accidents involve inexperienced operators. In fact, many operators who have been invol-

ved in accidents do not even have a current driver's license.

- Make sure that you are qualified and that you only lend your scooter to other qualified operators.
- Know your skills and limits. Staying within your limits may help you to avoid an accident.
- We recommend that you practice riding your scooter where there is no traffic until you have become thoroughly familiar with the scooter and all of its controls.
- Many accidents have been caused by error of the scooter operator. A typical error made by the operator is veering wide on a turn due to EXCESSIVE SPEED or undercornering (insufficient lean angle for the speed).
- Always obey the speed limit and never travel faster than warranted by road and traffic conditions.
- Always signal before turning or changing lanes. Make sure that other motorists can see you.

- The posture of the operator and passenger is important for proper control.
- The operator should keep both hands on the handlebar and both feet on the footboard during operation to maintain control of the scooter.
- The passenger should always hold onto the operator, the seat strap or grab bar, if equipped, with both hands and keep both feet on the passenger footrests.
- Never carry a passenger unless he or she can firmly place both feet on the passenger footrests.
- Never ride under the influence of alcohol or other drugs.
- This scooter is designed for on-road use only. It is not suitable for off-road use.

Protective apparel

The majority of fatalities from scooter accidents are the result of head injuries. The use of a safety helmet is the single most critical factor in the prevention or reduction of head injuries.

- Always wear an approved helmet.
- Wear a face shield or goggles. Wind in your unprotected eyes could contribute to an impairment of vision which could delay seeing a hazard.
- The use of a jacket, substantial shoes, trousers, gloves, etc., is effective in preventing or reducing abrasions or lacerations.
- Never wear loose-fitting clothes, otherwise they could catch on the control levers or wheels and cause injury or an accident.
- Never touch the engine or exhaust system during or after operation. They become very hot and can cause burns. Always wear protective clothing that covers your legs, ankles, and feet.
- Passengers should also observe the above precautions.

Modifications

Modifications made to this scooter not approved by Yamaha, or the removal of original equipment, may render the scooter unsafe for use and

may cause severe personal injury. Modifications may also make your scooter illegal to use.

Loading and accessories

Adding accessories or cargo to your scooter can adversely affect stability and handling if the weight distribution of the scooter is changed. To avoid the possibility of an accident, use extreme caution when adding cargo or accessories to your scooter. Use extra care when riding a scooter that has added cargo or accessories. Here are some general guidelines to follow if loading cargo or adding accessories to your scooter:

Loading

The total weight of the operator, passenger, accessories and cargo must not exceed the maximum load limit.

<p>Maximum load: 177 kg (390.29 lb)</p>
--

When loading within this weight limit, keep the following in mind:

- Cargo and accessory weight should be kept as low and close to the scooter as possible. Make

SAFETY INFORMATION

1

sure to distribute the weight as evenly as possible on both sides of the scooter to minimize imbalance or instability.

- Shifting weights can create a sudden imbalance. Make sure that accessories and cargo are securely attached to the scooter before riding. Check accessory mounts and cargo restraints frequently.
- Never attach any large or heavy items to the handlebar, front fork, or front fender. Such items can create unstable handling or a slow steering response.

Accessories

Genuine Yamaha accessories have been specifically designed for use on this scooter. Since Yamaha cannot test all other accessories that may be available, you must personally be responsible for the proper selection, installation and use of non-Yamaha accessories. Use extreme caution when selecting and installing any accessories.

Keep the following guidelines in mind, as well as those provided under “Loading” when mounting accessories.

- Never install accessories or carry cargo that would impair the performance of your scooter. Carefully inspect the accessory before using it to make sure that it does not in any way reduce ground clearance or cornering clearance, limit suspension travel, steering travel or control operation, or obscure lights or reflectors.
- Accessories fitted to the handlebar or the front fork area can create instability due to improper weight distribution or aerodynamic changes. If accessories are added to the handlebar or front fork area, they must be as lightweight as possible and should be kept to a minimum.
- Bulky or large accessories may seriously affect the stability of the scooter due to aerodynamic effects. Wind may attempt to lift the scooter, or the scoo-

ter may become unstable in cross winds. These accessories may also cause instability when passing or being passed by large vehicles.

- Certain accessories can displace the operator from his or her normal riding position. This improper position limits the freedom of movement of the operator and may limit control ability, therefore, such accessories are not recommended.
- Use caution when adding electrical accessories. If electrical accessories exceed the capacity of the scooter’s electrical system an electric failure could result, which could cause a dangerous loss of lights or engine power.

Gasoline and exhaust gas

- **GASOLINE IS HIGHLY FLAMMABLE:**
 - Always turn the engine off when refueling.
 - Take care not to spill any gasoline on the engine or exhaust system when refueling.

- Never refuel while smoking or in the vicinity of an open flame.
- Never start the engine or let it run for any length of time in a closed area. The exhaust fumes are poisonous and may cause loss of consciousness and death within a short time. Always operate your scooter in an area that has adequate ventilation.
- Always turn the engine off before leaving the scooter unattended and remove the key from the main switch. When parking the scooter, note the following:
 - The engine and exhaust system may be hot, therefore, park the scooter in a place where pedestrians or children are not likely to touch these hot areas.
 - Do not park the scooter on a slope or soft ground, otherwise it may fall over.
 - Do not park the scooter near a flammable source (e.g., a kerosene heater, or near an open flame), otherwise it could catch fire.

- If you should swallow any gasoline, inhale a lot of gasoline vapor, or allow gasoline to get into your eyes, see your doctor immediately. If any gasoline spills on your skin or clothing, immediately wash the affected area with soap and water and change your clothes.

EAU10371

Further safe-riding points

- Be sure to signal clearly when making turns.
- Braking can be extremely difficult on a wet road. Avoid hard braking, because the scooter could slide. Apply the brakes slowly when stopping on a wet surface.
- Slow down as you approach a corner or turn. Once you have completed a turn, accelerate slowly.
- Be careful when passing parked cars. A driver might not see you and open a door in your path.
- Railroad crossings, streetcar rails, iron plates on road construction sites, and manhole

covers become extremely slippery when wet. Slow down and cross them with caution. Keep the scooter upright, otherwise it could slide out from under you.

- The brake pads could get wet when you wash the scooter. After washing the scooter, check the brakes before riding.
- Always wear a helmet, gloves, trousers (tapered around the cuff and ankle so they do not flap), and a bright colored jacket.
- Do not carry too much luggage on the scooter. An overloaded scooter is unstable.

DESCRIPTION

EAU10410

Left view

2

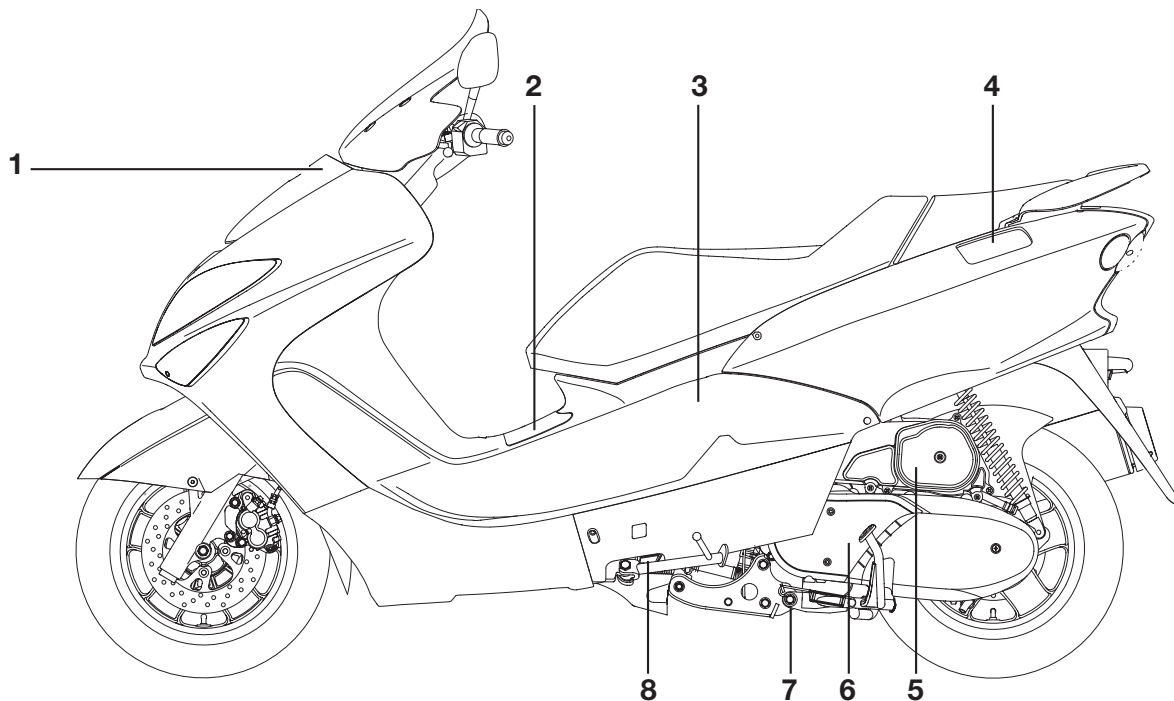

- 1. Coolant reservoir cap (page 6-12)
- 2. Battery (page 6-24)
- 3. Storage compartment (page 3-11)
- 4. Fuel tank cap (page 3-7)

- 5. Air filter (page 6-14)
- 6. V-Belt air filter (page 6-14)
- 7. Engine oil drain bolt (page 6-9)
- 8. Sidestand (page 3-12)

Right view

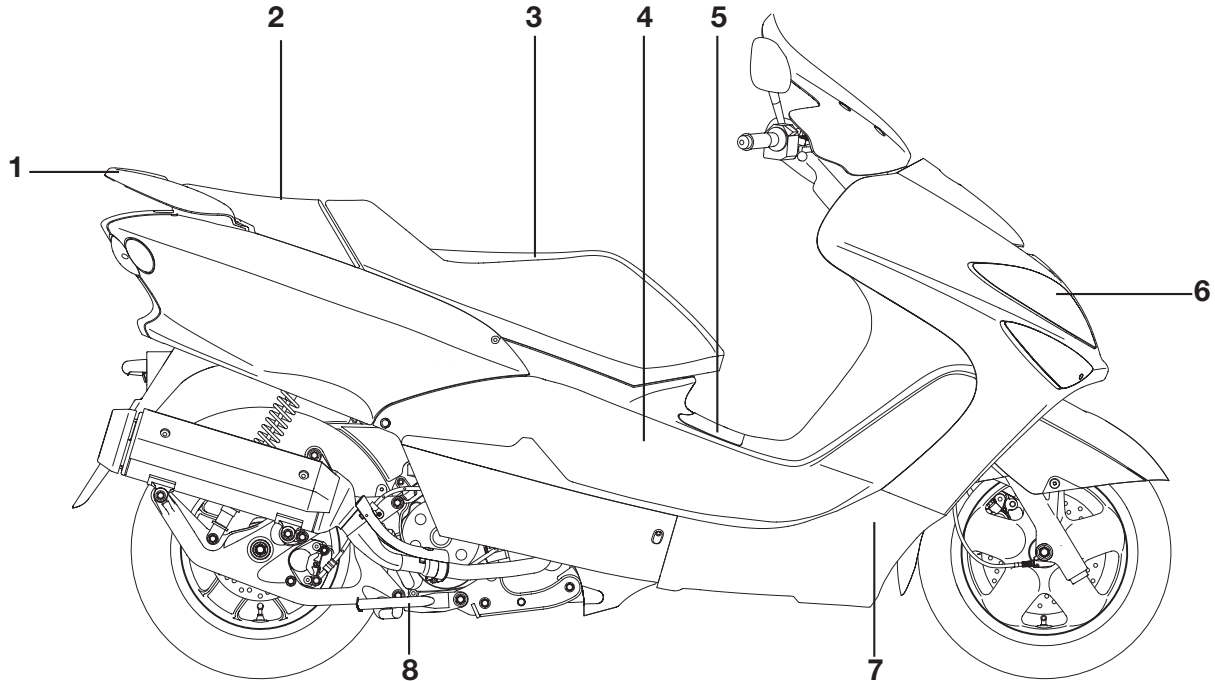

- 1. Grab bar
- 2. Passenger Seat
- 3. Rider Seat (page 3-9)
- 4. Owner's tool kit (page 6-1)

- 5. Fuses (page 6-26)
- 6. Headlight (page 6-27)
- 7. Radiator
- 8. Centerstand (page 6-22)

DESCRIPTION

EAU10430

Controls and instruments

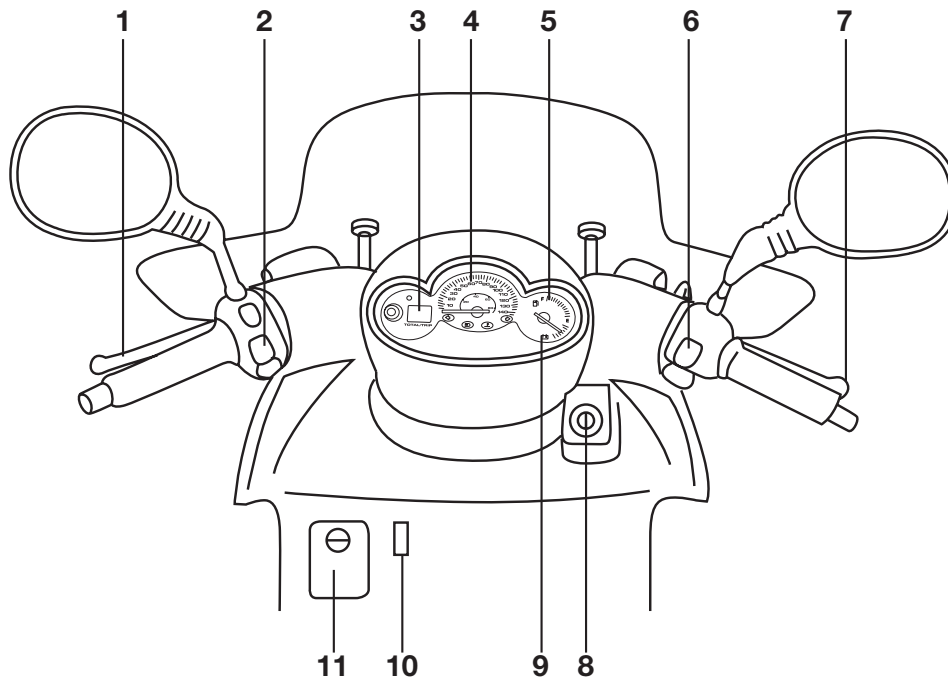

1. Rear brake lever (page 3-6)
2. Left handlebar switch (page 3-5)
3. Multi-function display (page 3-2)
4. Speedometer (page 3-2)
5. Fuel gauge (page 3-3)
6. Right handlebar switch (page 3-5)

7. Front brake lever (page 3-6)
8. Main switch (page 3-1)
9. Battery voltage (page 3-3)
10. Coolant level gauge window (page 6-12)
11. Front storage compartment (page 3-10)

INSTRUMENT AND CONTROL FUNCTIONS

EAU10460

Main switch/steering lock

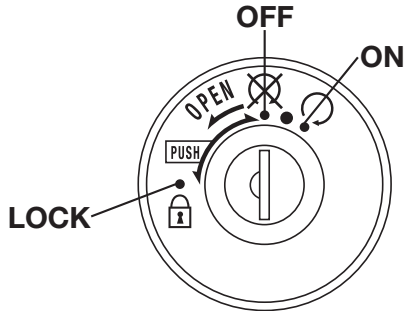

The main switch/steering lock controls the ignition and lighting systems, and is used to lock the steering. The various positions are described below.

EAU34121

ON “○”

All electrical circuits are supplied with power; the meter lighting, taillight, license plate light and auxiliary lights come on, and the engine can be started. The key cannot be removed.

NOTE:

The headlights come on automatically when the engine is started and stay on until the key is turned to "OFF" or the sidestand is moved down.

EAU10060

OFF “⊗”

All electrical systems are off. The key can be removed.

EAUM1020

“⊙”

The coolant temperature warning light should come on when the key is turned to “⊙”. (See page 3-2.)

EAU10680

LOCK “🔒”

The steering is locked, and all electrical systems are off. The key can be removed.

To lock the steering

1. Turn the handlebars all the way to the left.
2. Push the key in from the “⊗” position, and then turn it to “🔒” while still pushing it.
3. Remove the key.

To unlock the steering

Push the key in, and then turn it to “⊗” while still pushing it.

EWA10060

⚠ WARNING

Never turn the key to “⊗” or “🔒” while the vehicle is moving, otherwise the electrical systems will be switched off, which may result in loss of control or an accident. Make sure that the vehicle is stopped before turning the key to “⊗” or “🔒”.

INSTRUMENT AND CONTROL FUNCTIONS

EAU10980

Indicator lights

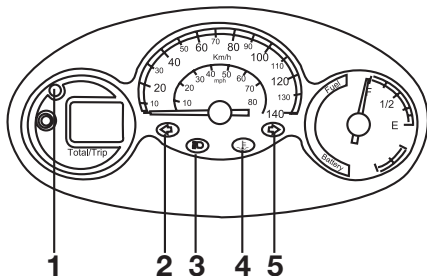

1. Alarm indicator light
2. Left turn signal indicator light “←”
3. High beam indicator light “≡”
4. Coolant temperature warning light “ ”
5. Right turn signal indicator light “→”

EAU11030

Turn signal indicator lights “←” and “→”

The corresponding indicator light flashes when the turn signal switch is pushed to the left or right.

EAU11080

High beam indicator light “≡”

This indicator light comes on when the high beam of the headlight is switched on.

EAUM1070

Oil change indicator

At the initial 500 km (300 mi) and every 3000 km (1800 mi) thereafter, the message “CHnGE OIL” appears in the odometer/clock display to indicate that the engine oil should be changed. (See page 6-9.)

EAUM1080

Coolant temperature warning light “ ”

This warning light comes on when the engine overheats. When this occurs, stop the engine immediately and allow the engine to cool.

The electrical circuit of the warning light can be checked according to the following procedure.

1. Turn the key to “○”.
2. If the warning light does not come on, have a Yamaha dealer check the electrical circuit.

CAUTION:

Do not operate the engine if it is overheated.

EAUS1361

Speedometer unit

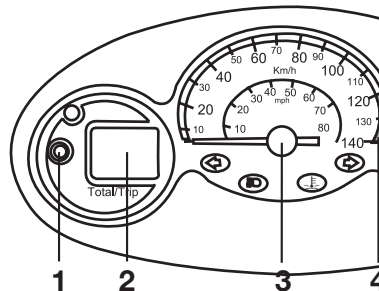

1. “TRIP” button
2. Multi-function display
3. Speedometer
4. Red zone

The speedometer unit is equipped with the following:

- a speedometer (which shows the riding speed)

ECAS0010

CAUTION:

Do not operate the scooter in the speedometer red zone. Red zone: 120 km/h (75 mph) and above

- an odometer (which shows the total distance traveled)
- a tripmeter (which shows the distance traveled since it was last set to zero)

INSTRUMENT AND CONTROL FUNCTIONS

EAUM1100

Pushing the “TRIP” button switches the display between the odometer mode “ODO” and the tripmeter mode “TRIP”. To reset the tripmeter, enter the “TRIP” mode, and then hold down the “TRIP” button for at least one second. The tripmeter can be used together with the fuel gauge to estimate the distance that can be traveled with a full tank of fuel. This information will enable you to plan future fuel stops.

Setting the odometer/tripmeter reading mode

The odometer and tripmeter can be set to count in either kilometers or miles according to the following procedure.

1. Turn the key to “○” while pressing the reset button.
2. Release the reset button when the display comes on.
3. The current mode appears in the display: “CONT” (continental) for the kilometer mode and “EnGL” (English) for the mile mode.
4. Press the reset button to switch the mode.

5. Press the reset button for two seconds to confirm the setting.

NOTE:

- The odometer/tripmeter reading mode can be changed any number of times while the odometer reading is below 10 (km/h or MPH), but it cannot be changed anymore after the reading has reached 10 (km/h or MPH).
- Switching between the kilometer mode and the mile mode does not change or convert the current odometer/tripmeter reading.

Battery voltage/fuel gauge

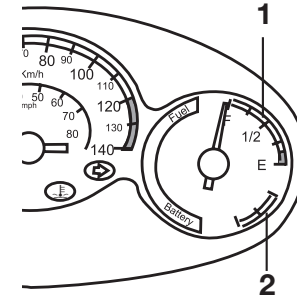

1. Fuel gauge
2. Battery voltage

When the key is turned to “⊗”, the voltage/fuel gauge indicates the battery voltage.

NOTE:

If the battery voltage drops to 10 V, have a Yamaha dealer check the battery.

When the key is turned to “○”, the voltage/fuel gauge indicates the amount of fuel in the fuel tank after indicating the battery voltage for two seconds. The needle moves towards “E” (empty) as the fuel level decrea-

INSTRUMENT AND CONTROL FUNCTIONS

ses. When the needle reaches “E”, refuel as soon as possible.

NOTE:

Do not allow the fuel tank to empty itself completely.

EAUS1210

Clock To set the clock

1. Turn the key to “O”.

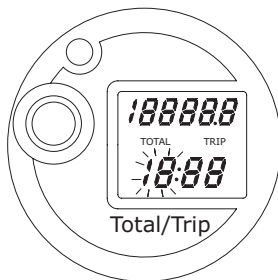

2. Press the “TRIP” button for two seconds, and the hour display will flash.
3. Press the “TRIP” button to set the hours.



4. Press the “TRIP” button for two seconds, and the first minute digit will flash.
5. Press the “TRIP” button to set the first minute digit.

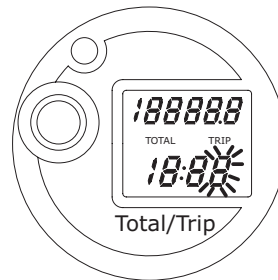

6. Press the “TRIP” button for two more seconds, and the second minute digit will flash.
7. Press the “TRIP” button to set the second minute digit.
8. Press the “TRIP” button for two seconds to set the clock.

INSTRUMENT AND CONTROL FUNCTIONS

EAU12331

Anti-theft alarm (optional)

This motorcycle can be equipped with an optional anti-theft alarm by a Yamaha dealer. Contact a Yamaha dealer for more information.

EAU12347

Handlebar switches

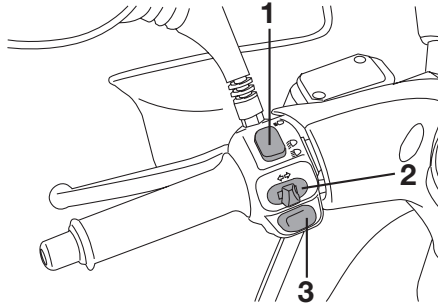

1. Dimmer switch “ \equiv D/ \equiv D”
2. Turn signal switch “ \leftarrow / \rightarrow ”
3. Horn switch “ H ”

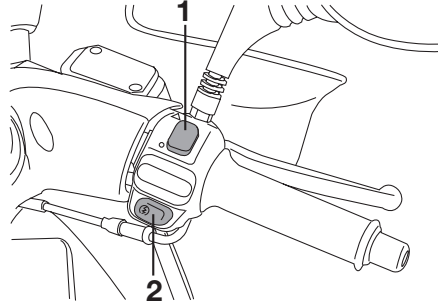

1. Hazard switch “ \triangle ”
2. Start switch “ S ”

EAU12020

Dimmer switch “ \equiv D/ \equiv D”

Set this switch to “ \equiv D” for the high beam and to “ \equiv D” for the low beam. With the headlight on low beam, press this switch downwards to flash the headlight.

EAU12460

Turn signal switch “ \leftarrow / \rightarrow ”

To signal a right-hand turn, push this switch to “ \rightarrow ”. To signal a left-hand turn, push this switch to “ \leftarrow ”. When released, the switch returns to the center position. To cancel the turn signal lights, push the switch in after it has returned to the center position.

EAU12500

Horn switch “ H ”

Press this switch to sound the horn.

EAU12720

Start switch “ S ”

With the sidestand up, push this switch while applying the front or rear brake to crank the engine with the starter.

INSTRUMENT AND CONTROL FUNCTIONS

CAUTION:

ECA10050

See page 5-1 for starting instructions prior to starting the engine.

Hazard switch “▲”

EAU12764

With the key in the “○” position, turn this switch to “▲” to turn on the hazard lights (simultaneous flashing of all turn signal lights).

The hazard lights are used in case of an emergency or to warn other drivers when your vehicle is stopped where it might be a traffic hazard.

ECA10061

CAUTION:

Do not use the hazard lights for an extended length of time with the engine not running, otherwise the battery may discharge.

EAU12900

Front brake lever

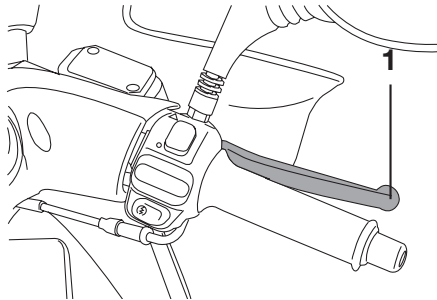

1. Front brake lever

The front brake lever is located on the right handlebar grip. To apply the front brake, pull this lever toward the handlebar grip.

EAU12950

Rear brake lever

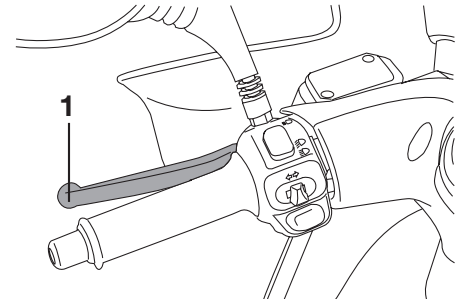

1. Rear brake lever

The rear brake lever is located on the left handlebar grip. To apply the rear brake, pull this lever toward the handlebar grip.

INSTRUMENT AND CONTROL FUNCTIONS

EAUS1040

Fuel tank cap

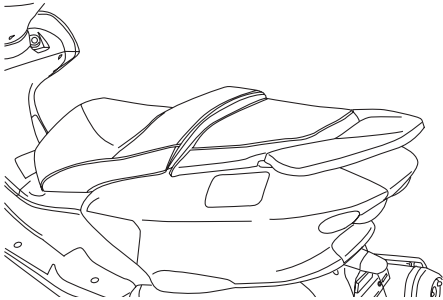

To open the fuel tank cap

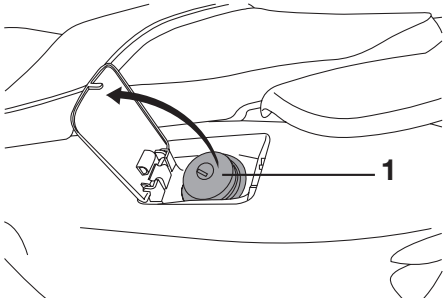

1. Fuel tank cap

1. Open the fuel tank cap cover by pushing in on the rear end of it.

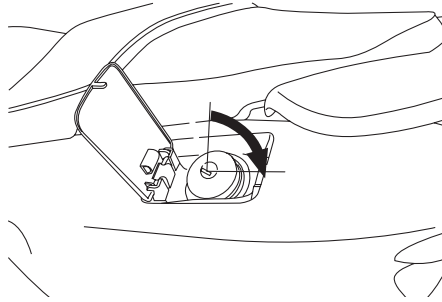

2. Insert the key in the lock and turn it clockwise.

To close the fuel tank cap

1. Align the match marks, and then push the fuel tank cap into the original position.

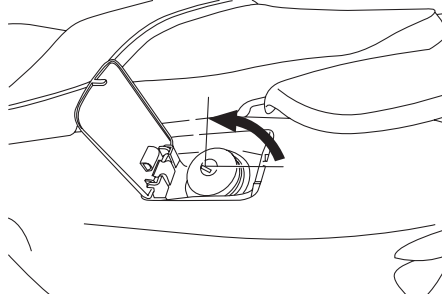

2. Turn the key counterclockwise and remove it.

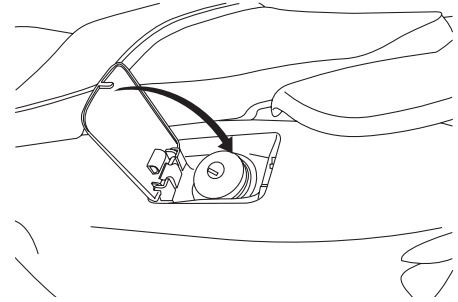

3. Close the fuel tank cover.

INSTRUMENT AND CONTROL FUNCTIONS

Fuel

EAU13220

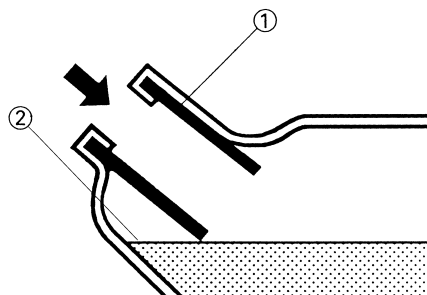

1. Fuel tank filler tube
2. Fuel level

Make sure that there is sufficient fuel in the tank. When refueling, be sure to insert the pump nozzle into the fuel tank filler hole and to fill the tank to the bottom of the filler tube as shown.

EWA10880

⚠ WARNING

- Do not overfill the fuel tank, otherwise it may overflow when the fuel warms up and expands.
- Avoid spilling fuel on the hot engine.

ECA10070

CAUTION:

Immediately wipe off spilled fuel with a clean, dry, soft cloth, since fuel may deteriorate painted surfaces or plastic parts.

EAU33520

Recommended fuel:

REGULAR UNLEADED GASOLINE ONLY

Fuel tank capacity:

10.5 L (2.77US gal) (2.31 Imp.gal)

Fuel reserve amount

3 L (0.79 US gal) (0.66 Imp gal)

ECA11400

CAUTION:

Use only unleaded gasoline. The use of leaded gasoline will cause severe damage to internal engine parts, such as the valves and piston rings, as well as to the exhaust system.

Your Yamaha engine has been designed to use regular unleaded gasoline with a research octane number of 91 or higher. If knocking (or pinging) occurs, use a gasoline of a different brand or premium unleaded fuel. Use of unleaded fuel will extend spark plug life and reduce maintenance costs.

INSTRUMENT AND CONTROL FUNCTIONS

EAUB1300

Fuel tank breather/overflow hose

Before operating the motorcycle:

- Check the fuel tank breather/overflow hose connection.
- Check the fuel tank breather/overflow hose for cracks or damage, and replace it if damaged.
- Make sure that the end of the fuel tank breather/overflow hose is not blocked, and clean it if necessary.
- Make sure that the end of the fuel tank breather/overflow hose is positioned inside of the clamp.

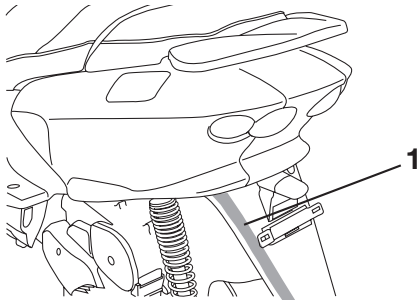

1. Fuel tank breather/overflow hose

EAU13431

Catalytic converter

This model is equipped with a catalytic converter in the exhaust system.

EWA10860

WARNING

The exhaust system is hot after operation. Make sure that the exhaust system has cooled down before doing any maintenance work.

ECA10700

CAUTION:

The following precautions must be observed to prevent a fire hazard or other damages.

- Use only unleaded gasoline. The use of leaded gasoline will cause unreparable damage to the catalytic converter.
- Never park the vehicle near possible fire hazards such as grass or other materials that easily burn.
- Do not allow the engine to idle too long.

EAU13891

Seat

To open the seat

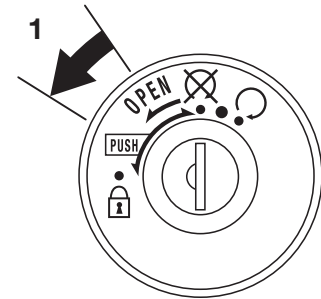

1. Open

1. Insert the key in the lock, and then turn it as shown.

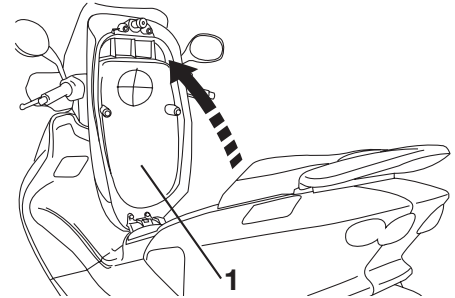

1. Rider seat

2. Fold the seat up.

INSTRUMENT AND CONTROL FUNCTIONS

To close the seat

1. Fold the seat down, and then push it down to lock it in place.
2. Remove the key.

NOTE:

Make sure that the seat is properly secured before riding.

3

EAU14540

Front storage compartment

To open the front storage compartment

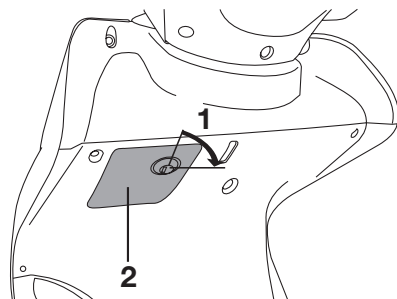

1. Open
2. Lid

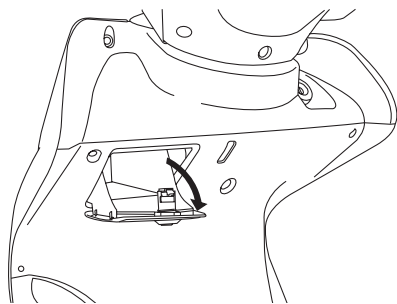

Insert the key into the lock, turn it clockwise, and then pull on it to open the front storage compartment lid.

To close the front storage compartment

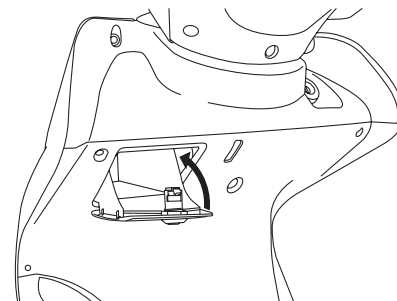

Push the front storage compartment lid into the original position, and then remove the key.

EWA10960

⚠ WARNING

- Do not exceed the load limit of 0.5 kg (1.10 lb) for the front storage compartment.
- Do not exceed the maximum load of 177 kg (390.29 lb) for the vehicle.

INSTRUMENT AND CONTROL FUNCTIONS

EAUM1190

ECA10080

Storage compartment

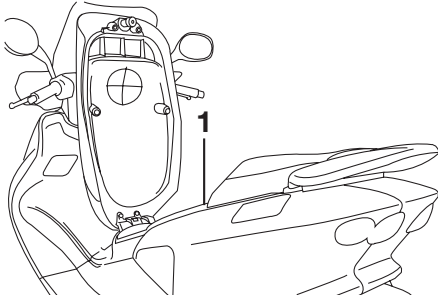

1. Storage compartment

There is a storage compartment under the seat. (See page 3-9.)

⚠ WARNING

EWA10960

- Do not exceed the load limit of 10 kg (22 lb) for the storage compartment.
- Do not exceed the maximum load of 177 kg (390.29 lb) for the vehicle.

CAUTION:

Keep the following points in mind when using the storage compartment.

- Since the storage compartment accumulates heat when exposed to the sun, do not store anything susceptible to heat inside it.
- To avoid humidity from spreading through the storage compartment, wrap wet articles in a plastic bag before storing them in the compartment.
- Since the storage compartment may get wet while the scooter is being washed, wrap any articles stored in the compartment in a plastic bag.
- Do not keep anything valuable or breakable in the storage compartment.

To store a helmet in the storage compartment, place the helmet with the frontfacing backward.

NOTE:

- Some helmets cannot be stored in the storage compartment because of their size or shape.
- Do not leave your scooter unattended with the seat open.

INSTRUMENT AND CONTROL FUNCTIONS

EAU14880

Adjusting the shock absorber assemblies

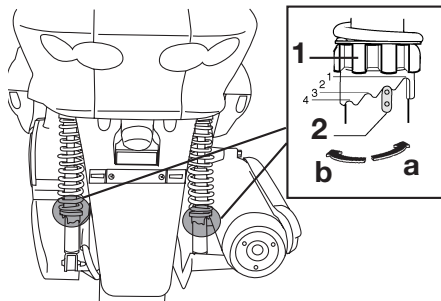

1. Spring preload adjusting ring
2. Position indicator

Each shock absorber assembly is equipped with a spring preload adjusting ring.

ECA10100

CAUTION:

Never attempt to turn an adjusting mechanism beyond the maximum or minimum settings.

EWA10210

⚠ WARNING

Always adjust both shock absorber assemblies equally, otherwise poor handling and loss of stability may result.

Adjust the spring preload as follows. To increase the spring preload and thereby harden the suspension, turn the adjusting ring on each shock absorber assembly in direction (a). To decrease the spring preload and thereby soften the suspension, turn the adjusting ring on each shock absorber assembly in direction (b).

NOTE:

Align the appropriate notch in the adjusting ring with the position indicator on the shock absorber.

Spring preload setting:

- Minimum (soft):
1
- Standard:
2
- Maximum (hard):
4

EAU15301

Sidestand

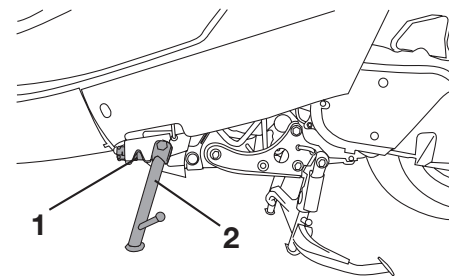

1. Sidestand switch
2. Sidestand

The sidestand is located on the left side of the frame. Raise the sidestand or lower it with your foot while holding the motorcycle upright.

NOTE:

The built-in sidestand switch is part of the ignition circuit cut-off system, which cuts the ignition in certain situations. (See further down for an explanation of the ignition circuit cut-off system.)

EWA10240

EAU15361

WARNING

The vehicle must not be ridden with the sidestand down, or if the sidestand cannot be properly moved up (or does not stay up), otherwise the sidestand could contact the ground and distract the operator, resulting in a possible loss of control. Yamaha's ignition circuit cut-off system has been designed to assist the operator in fulfilling the responsibility of raising the sidestand before starting off. Therefore, check this system regularly as described below and have a Yamaha dealer repair it if it does not function properly.

Ignition circuit cut-off system

The ignition circuit cut-off system (comprising the sidestand switch and brake light switches) has the following functions.

- It prevents starting when the sidestand is up, but neither brake is applied.
- It prevents starting when either brake is applied, but the sidestand is still down.
- It cuts the running engine when the sidestand is moved down.

Periodically check the operation of the ignition circuit cut-off system according to the following procedure.

EWA10260

WARNING

- The vehicle must be placed on the centerstand during this inspection.
- If a malfunction is noted, have a Yamaha dealer check the system before riding.

INSTRUMENT AND CONTROL FUNCTIONS

3

With the engine turned off:
1. Move the sidestand down.
2. Make sure that the engine stop switch is turned on.
3. Turn the key on.
4. Keep the front or rear brake applied.
5. Push the start switch.
Does the engine start?

NO

YES

NOTE:

This check is most reliable if performed with a warmed-up engine.

The sidestand switch may be defective.
The scooter should not be ridden until checked by a Yamaha dealer.

With the engine still off:
6. Move the sidestand up.
7. Keep the front or rear brake applied.
8. Push the start switch.
Does the engine start?

YES

NO

The brake switch may be defective.
The scooter should not be ridden until checked by a Yamaha dealer.

With the engine still running:
9. Move the sidestand down.
Does the engine stall?

YES

NO

The sidestand switch may be defective.
The scooter should not be ridden until checked by a Yamaha dealer.

The system is OK. **The scooter can be ridden.**

EAU15591

The condition of a vehicle is the owner's responsibility. Vital components can start to deteriorate quickly and unexpectedly, even if the vehicle remains unused (for example, as a result of exposure to the elements). Any damage, fluid leakage or loss of tire air pressure could have serious consequences. Therefore, it is very important, in addition to a thorough visual inspection, to check the following points before each ride.

NOTE: _____

Pre-operation checks should be made each time the vehicle is used. Such an inspection can be accomplished in a very short time; and the added safety it assures is more than worth the time involved.

EWA11150

 WARNING _____

If any item in the Pre-operation check list is not working properly, have it inspected and repaired before operating the vehicle.

PRE-OPERATION CHECKS

EAU15605

Pre-operation check list

ITEM	CHECKS	PAGE
Fuel	<ul style="list-style-type: none"> • Check fuel level in fuel tank. • Refuel if necessary. • Check fuel line for leakage. 	3-3, 3-7
Engine oil	<ul style="list-style-type: none"> • Check oil level in engine. • If necessary, add recommended oil to specified level. • Check vehicle for oil leakage. 	3-2, 6-9
Final transmission oil	<ul style="list-style-type: none"> • Check vehicle for oil leakage. 	6-11
Coolant	<ul style="list-style-type: none"> • Check coolant level in reservoir. • If necessary, add recommended coolant to specified level. • Check cooling system for leakage. 	3-2, 6-12
Front brake	<ul style="list-style-type: none"> • Check operation. • If soft or spongy, have Yamaha dealer bleed hydraulic system. • Check brake pads for wear. • Replace if necessary. • Check fluid level in reservoir. • If necessary, add recommended brake fluid to specified level. • Check hydraulic system for leakage. 	3-6, 6-19, 6-20, 6-21
Rear brake	<ul style="list-style-type: none"> • Check operation. • If soft or spongy, have Yamaha dealer bleed hydraulic system. • Check brake pads for wear. • Replace if necessary. • Check fluid level in reservoir. • If necessary, add recommended brake fluid to specified level. • Check hydraulic system for leakage. 	3-6, 6-19, 6-20, 6-21
Throttle grip	<ul style="list-style-type: none"> • Make sure that operation is smooth. • Check cable free play. • If necessary, have Yamaha dealer adjust cable free play and lubricate cable and grip housing. 	5-2, 6-15
Wheels and tires	<ul style="list-style-type: none"> • Check for damage. • Check tire condition and tread depth. • Check air pressure. • Correct if necessary. 	6-16, 6-18

4

PRE-OPERATION CHECKS

ITEM	CHECKS	PAGE
Brake levers	<ul style="list-style-type: none">• Make sure that operation is smooth.• Lubricate lever pivoting points if necessary.	3-6, 5-2, 6-22
Centerstand, sidestand	<ul style="list-style-type: none">• Make sure that operation is smooth.• Lubricate pivots if necessary.	6-22
Chassis fasteners	<ul style="list-style-type: none">• Make sure that all nuts, bolts and screws are properly tightened.• Tighten if necessary.	---
Instruments, lights, signals and switches	<ul style="list-style-type: none">• Check operation.• Correct if necessary.	---
Sidestand switch	<ul style="list-style-type: none">• Check operation of ignition circuit cut-off system.• If system is defective, have Yamaha dealer check vehicle.	3-12
Battery	<ul style="list-style-type: none">• Check fluid level.• Fill with distilled water if necessary.	6-24

OPERATION AND IMPORTANT RIDING POINTS

EAU15980
EWA10870

⚠ WARNING

- Become thoroughly familiar with all operating controls and their functions before riding. Consult a Yamaha dealer regarding any control or function that you do not thoroughly understand.
- Never start the engine or operate it in a closed area for any length of time. Exhaust fumes are poisonous, and inhaling them can cause loss of consciousness and death within a short time. Always make sure that there is adequate ventilation.
- For safety, always start the engine with the centerstand down.

Starting a cold engine

EAUM1210

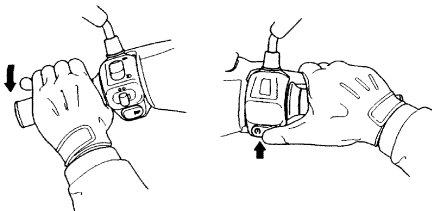

ZAJM0024

ECA10250

CAUTION:

See page 5-3 for engine break-in instructions prior to operating the vehicle for the first time.

1. Turn the key to “O”.
2. Close the throttle completely.
3. Start the engine by pushing the start switch while applying the front or rear brake.

NOTE:

If the engine fails to start, release the start switch, wait a few seconds, and then try again. Each starting attempt should be as short as possible to preserve the battery. Do not crank the

engine more than 10 seconds on any one attempt.

ECA11040

CAUTION:

For maximum engine life, never accelerate hard when the engine is cold!

OPERATION AND IMPORTANT RIDING POINTS

EAU16760

Starting off

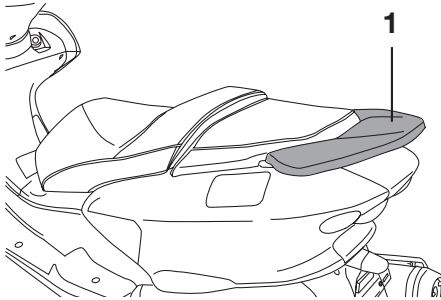

1. Grab bar

NOTE:

Before starting off, allow the engine to warm up.

1. While pulling the rear brake lever with your left hand and holding the grab bar with your right hand, push the scooter off the centerstand.
2. Sit astride the seat, and then adjust the rear view mirrors.
3. Switch the turn signal on.
4. Check for oncoming traffic, and then slowly turn the throttle grip (on the right) in order to take off.
5. Switch the turn signal off.

EAU16780

Acceleration and deceleration

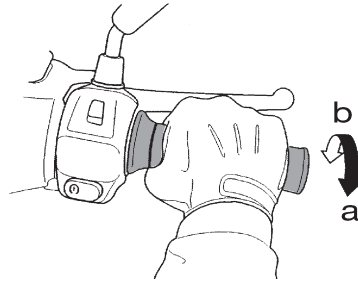

The speed can be adjusted by opening and closing the throttle. To increase the speed, turn the throttle grip in direction (a). To reduce the speed, turn the throttle grip in direction (b).

EAU16791

Braking



1. Close the throttle completely.
2. Apply both front and rear brakes simultaneously while gradually increasing the pressure.

5

EWA10300

⚠ WARNING

- **Avoid braking hard or suddenly (especially when leaning over to one side), otherwise the scooter may skid or overturn.**
- **Railroad crossings, streetcar rails, iron plates on road construction sites, and manhole covers become extremely slippery when wet. Therefore, slow down when approaching such**

OPERATION AND IMPORTANT RIDING POINTS

areas and cross them with caution.

- **Keep in mind that braking on a wet road is much more difficult.**
 - **Ride slowly down a hill, as braking downhill can be very difficult.**
-

EAU16820

EAU16830

Tips for reducing fuel consumption

Fuel consumption depends largely on your riding style. Consider the following tips to reduce fuel consumption:

- Avoid high engine speeds during acceleration.
- Avoid high engine speeds with no load on the engine.
- Turn the engine off instead of letting it idle for an extended length of time (e.g., in traffic jams, at traffic lights or at railroad crossings).

Engine break-in

There is never a more important period in the life of your engine than the period between 0 and 1000 km (600 mi). For this reason, you should read the following material carefully. Since the engine is brand new, do not put an excessive load on it for the first 1000 km (600 mi). The various parts in the engine wear and polish themselves to the correct operating clearances. During this period, prolonged full-throttle operation or any condition that might result in engine overheating must be avoided.

EAU16950

0 ~ 150 km (0 ~ 90 mi)

Avoid prolonged operation above 1/3 throttle.

After every hour of operation, stop the engine, and then let it cool for five to ten minutes.

Vary the engine speed from time to time. Do not operate the engine at one set throttle position.

OPERATION AND IMPORTANT RIDING POINTS

150 ~ 500 km (90 ~ 300 mi)

Avoid prolonged operation above 1/2 throttle.

Rev the engine freely through the gears, but do not use full throttle at any time.

500 ~ 1000 km (300 ~ 600 mi)

Avoid prolonged operation above 3/4 throttle.

ECA10350

CAUTION:

After 1000 km (600 mi) of operation, the engine oil must be changed and the oil strainer cleaned.

1000 km (600 mi) and beyond

Avoid prolonged full-throttle operation. Vary the speed occasionally.

ECA10270

CAUTION:

If any engine trouble should occur during the engine break-in period, immediately have a Yamaha dealer check the vehicle.

EAU17200

Parking

When parking, stop the engine, and then remove the key from the main switch.

EWA10310

WARNING

- Since the engine and exhaust system can become very hot, park in a place where pedestrians or children are not likely to touch them.
- Do not park on a slope or on soft ground, otherwise the vehicle may overturn.

PERIODIC MAINTENANCE AND MINOR REPAIR

EAU17280

Safety is an obligation of the owner. Periodic inspection, adjustment and lubrication will keep your vehicle in the safest and most efficient condition possible. The most important points of inspection, adjustment, and lubrication are explained on the following pages.

The intervals given in the periodic maintenance and lubrication chart should be simply considered as a general guide under normal riding conditions. However, DEPENDING ON THE WEATHER, TERRAIN, GEOGRAPHICAL LOCATION, AND INDIVIDUAL USE, THE MAINTENANCE INTERVALS MAY NEED TO BE SHORTENED.

EWA10320

⚠ WARNING

If you are not familiar with maintenance work, have a Yamaha dealer do it for you.

EWA10330

⚠ WARNING

This scooter is designed for use on paved roads only. If this scooter is operated in abnormally dusty, muddy or wet conditions, the air filter element should be cleaned or replaced more frequently, otherwise rapid engine wear may result. Consult a Yamaha dealer for proper maintenance intervals.

EAU17450

Owner's tool kit

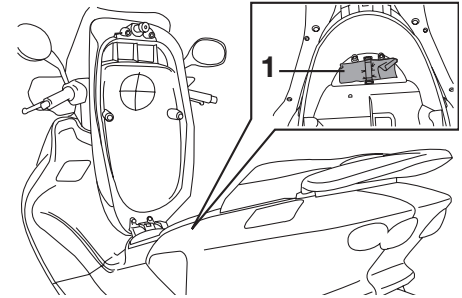

1. Owner's tool kit

The owner's tool kit is located inside the storage compartment. (See page 3-11.) The service information included in this manual and the tools provided in the owner's tool kit are intended to assist you in the performance of preventive maintenance and minor repairs. However, additional tools such as a torque wrench may be necessary to perform certain maintenance work correctly.

PERIODIC MAINTENANCE AND MINOR REPAIR

NOTE: _____

If you do not have the tools or experience required for a particular job, have a Yamaha dealer perform it for you.

EWA10350

 **WARNING**

Modifications not approved by Yamaha may cause loss of performance and render the vehicle unsafe for use. Consult a Yamaha dealer before attempting any changes.

PERIODIC MAINTENANCE AND MINOR REPAIR

EAU17710

Periodic maintenance and lubrication chart

NOTE:

- The annual checks must be performed every year, except if a kilometer-based maintenance is performed instead.
- From 30000 km, repeat the maintenance intervals starting from 6000 km.
- Items marked with an asterisk should be performed by a Yamaha dealer as they require special tools, data and technical skills.

NO.	ITEM	CHECK OR MAINTENANCE JOB	ODOMETER READING (x 1000 Km)					ANNUAL CHECK
			1	6	12	18	24	
1	* Fuel line	<ul style="list-style-type: none"> • Check fuel and vacuum hoses for cracks or damage. 		√	√	√	√	√
2	Spark plug	<ul style="list-style-type: none"> • Check condition. • Clean and regap. 		√		√		
		<ul style="list-style-type: none"> • Replace. 			√		√	
3	* Valves	<ul style="list-style-type: none"> • Check valve clearance. • Adjust. 		√	√	√	√	
4	Air filter element	<ul style="list-style-type: none"> • Clean. 		√		√		
		<ul style="list-style-type: none"> • Replace. 			√		√	
5	V-belt case air filter element	<ul style="list-style-type: none"> • Clean. 		√	√	√	√	
6	* Battery	<ul style="list-style-type: none"> • Check electrolyte level and specific gravity. • Make sure that the breather hose is properly routed. 		√	√	√	√	√
7	* Front brake	<ul style="list-style-type: none"> • Check operation, fluid level and vehicle for fluid leakage. 	√	√	√	√	√	√
		<ul style="list-style-type: none"> • Replace brake pads. 	Whenever worn to the limit					

PERIODIC MAINTENANCE AND MINOR REPAIR

NO.	ITEM	CHECK OR MAINTENANCE JOB	ODOMETER READING (x 1000 Km)					ANNUAL CHECK
			1	6	12	18	24	
8 *	Rear brake	• Check operation, fluid level and vehicle for fluid leakage.	√	√	√	√	√	√
		• Replace brake pads.	Whenever worn to the limit					
9 *	Brake hoses	• Check for cracks or damage.		√	√	√	√	√
		• Replace.	Every 4 years					
10 *	Wheels	• Check runout and for damage.		√	√	√	√	
11 *	Tires	• Check tread depth and for damage. • Replace if necessary. • Check air pressure. • Correct if necessary.		√	√	√	√	√
12 *	Wheel bearings	• Check bearing for looseness or damage.		√	√	√	√	
13 *	Steering bearings	• Check bearing play and steering for roughness.	√	√	√	√	√	
		• Lubricate with lithium-soap-based grease.	Every 20000 km					
14 *	Chassis fasteners	• Make sure that all nuts, bolts and screws are properly tightened.		√	√	√	√	√
15	Sidestand, centerstand	• Check operation. • Lubricate.		√	√	√	√	√
16 *	Sidestand switch	• Check operation.	√	√	√	√	√	√
17 *	Front fork	• Check operation and for oil leakage.		√	√	√	√	
18 *	Shock absorber assemblies	• Check operation and shock absorbers for oil leakage.		√	√	√	√	
19 *	Carburetor	• Adjust engine idling speed.	√	√	√	√	√	√
20	Engine oil	• Change. (See page 6-9.)	√	When the oil change indicator light comes on (every 3000 km)				
		• Check oil level and vehicle for oil leakage.	Every 3000 km					√
21 *	Engine oil strainer	• Clean.	√		√		√	

PERIODIC MAINTENANCE AND MINOR REPAIR

NO.	ITEM	CHECK OR MAINTENANCE JOB	ODOMETER READING (x 1000 Km)					ANNUAL CHECK
			1	6	12	18	24	
22	* Cooling system	<ul style="list-style-type: none"> • Check coolant level and vehicle for coolant leakage. • Change. 		√	√	√	√	√
			Every 3 years					
23	Final transmission oil	<ul style="list-style-type: none"> • Check vehicle for oil leakage. • Initial 500 km • Change. 	√		√			
				√		√		
24	* V-belt	<ul style="list-style-type: none"> • Replace. 	Every 10000 km					
25	* Front and rear brake switches	<ul style="list-style-type: none"> • Check operation. 	√	√	√	√	√	√
26	Moving parts and cables	<ul style="list-style-type: none"> • Lubricate. 		√	√	√	√	√
27	* Throttle grip housing and cable	<ul style="list-style-type: none"> • Check operation and free play. • Adjust the throttle cable free play if necessary. • Lubricate the throttle grip housing and cable. 		√	√	√	√	√
28	* Mufflers and exhaust pipes	<ul style="list-style-type: none"> • Check the screw clamps for looseness. 	√	√	√	√	√	√
29	* Lights, signals and switches	<ul style="list-style-type: none"> • Check operation. • Adjust headlight beam. 	√	√	√	√	√	√

EAUM2070

NOTE:

- The air filter needs more frequent service if you are riding in unusually wet or dusty areas.
- Hydraulic brake service
 - Regularly check and, if necessary, correct the brake fluid level.
 - Every two years change the brake fluid.
 - Replace the brake hoses every four years and if cracked or damaged.

PERIODIC MAINTENANCE AND MINOR REPAIR

Removing and installing panels

EAU18771

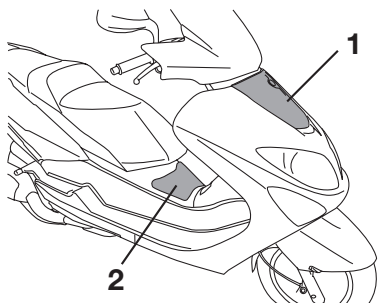

1. Panel A
2. Panel B

The panels shown need to be removed to perform some of the maintenance jobs described in this chapter. Refer to this section each time a panel needs to be removed and installed.

Panel A

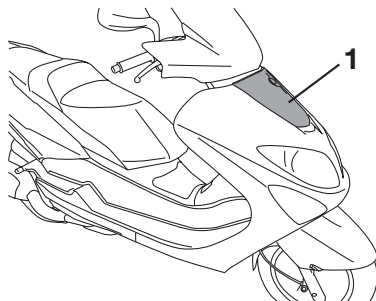

1. Panel A

To remove the panel

Remove the screws, and then take the panel off.

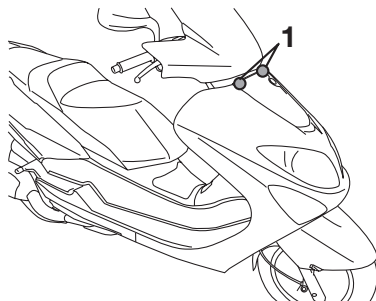

1. Screw

EAU19210

To install the panel

Place the panel in the original position, and then install the screws.

Panel B

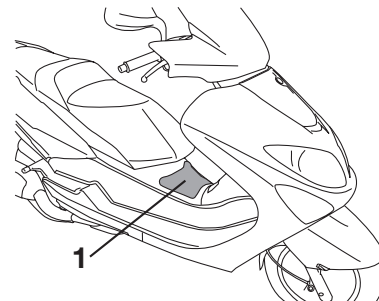

1. Panel B

To remove the panel

Remove the screw, and then take the panel off.

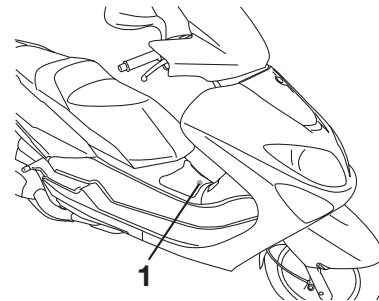

1. Screw

PERIODIC MAINTENANCE AND MINOR REPAIR

To install the panel

Place the panel in the original position, and then install the screw.

EAU19603

Checking the spark plug

The spark plug is an important engine component, which is easy to check. Since heat and deposits will cause any spark plug to slowly erode, the spark plug should be removed and checked in accordance with the periodic maintenance and lubrication chart. In addition, the condition of the spark plug can reveal the condition of the engine.

To remove the spark plug

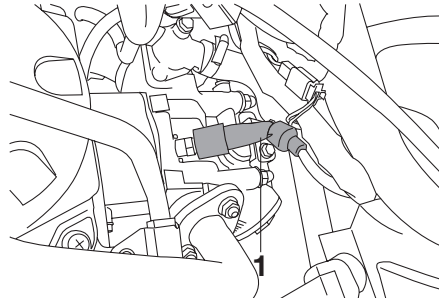

1. Spark plug cap

1. Remove the spark plug cap.

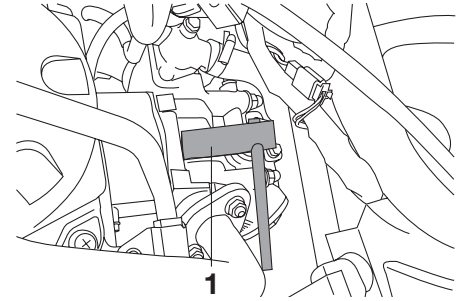

1. Spark plug wrench

2. Remove the spark plug as shown, with the spark plug wrench included in the owner's tool kit.

To check the spark plug

1. Check that the porcelain insulator around the center electrode of the spark plug is a medium-to-light tan (the ideal color when the vehicle is ridden normally).

PERIODIC MAINTENANCE AND MINOR REPAIR

NOTE:

If the spark plug shows a distinctly different color, the engine could be operating improperly. Do not attempt to diagnose such problems yourself. Instead, have a Yamaha dealer check the vehicle.

2. Check the spark plug for electrode erosion and excessive carbon or other deposits, and replace it if necessary.

Specified spark plug:
NGK (CR8E)

To install the spark plug

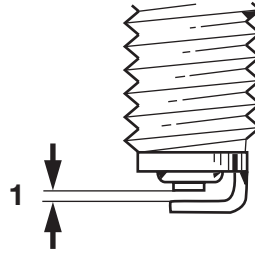

1. Spark plug gap

1. Measure the spark plug gap with a wire thickness gauge and, if necessary, adjust the gap to specification.

Spark plug gap:
0.7 ~ 0.8 (0.02 ~ 0.03 in)

2. Clean the surface of the spark plug gasket and its mating surface, and then wipe off any grime from the spark plug threads.
3. Install the spark plug with the spark plug wrench, and then tighten it to the specified torque.

Tightening torque:

Spark plug:
20 Nm (2.0 m•kgf, 14.5 ft•lbf)

NOTE:

If a torque wrench is not available when installing a spark plug, a good estimate of the correct torque is 1/4 ~ 1/2 turn past finger tight. However, the spark plug should be tightened to the specified torque as soon as possible.

4. Install the spark plug cap.

PERIODIC MAINTENANCE AND MINOR REPAIR

EAUM1260

Engine oil

The engine oil level should be checked before each ride. In addition, the oil must be changed at the intervals specified in the periodic maintenance and lubrication chart and when the oil change indicator display comes on.

To check the engine oil level

1. Place the scooter on the centerstand.

NOTE:

Make sure that the scooter is positioned straight up when checking the oil level. A slight tilt to the side can result in a false reading.

2. Start the engine, warm it up for several minutes, and then turn it off.

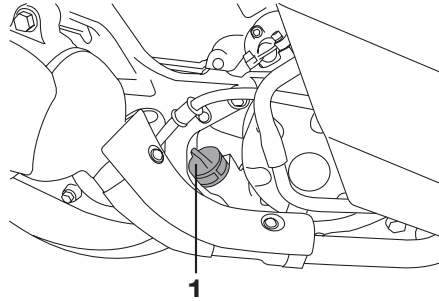

1. Engine oil filler cap

3. Wait a few minutes until the oil settles, remove the oil filler cap, wipe the dipstick clean, insert it back into the oil filler hole (without screwing it in), and then remove it again to check the oil level.

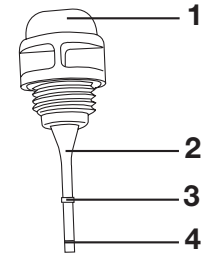

1. Engine oil filler cap
2. Dipstick
3. Maximum level mark
4. Minimum level mark

NOTE:

The engine oil should be between the minimum and maximum level marks.

4. If the engine oil is below the minimum level mark, add sufficient oil of the recommended type to raise it to the correct level.
5. Insert the dipstick into the oil filler hole, and then tighten the oil filler cap.

To change the engine oil

1. Start the engine, warm it up for several minutes, and then turn it off.

PERIODIC MAINTENANCE AND MINOR REPAIR

ECA11670

2. Place an oil pan under the engine to collect the used oil.

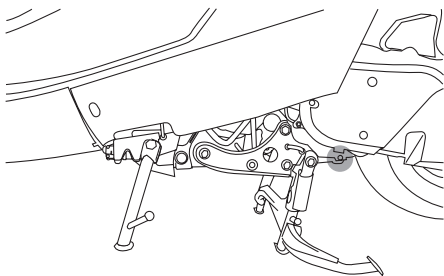

3. Remove the engine oil filler cap and the engine oil drain bolt to drain the oil from the crankcase.

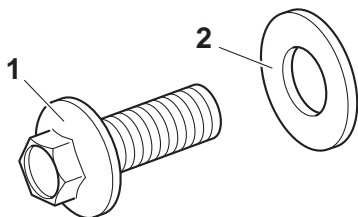

1. Engine oil drain bolt
2. Washer

4. Check the washer for damage and replace it if necessary.
5. Install the washer and the engine oil drain bolt, and then tighten the drain bolt to the specified torque.

Tightening torque:

Engine oil drain bolt:
32 Nm (3.2 m•kgf, 23.1 ft•lbf)

NOTE:

Make sure that the washer is properly seated.

6. Add the specified amount of the recommended engine oil, and then install and tighten the oil filler cap.

Recommended engine oil:

See page 8-1.

Oil change quantity:

1.2 L (1.27 US qt) (1.06 Imp.qt)

CAUTION:

- Do not use oils with a diesel specification of "CD" or oils of a higher quality than specified. In addition, do not use oils labeled "ENERGY CONSERVING II" or higher.
- Be sure no foreign material enters the crankcase.

7. Start the engine, and then let it idle for several minutes while checking it for oil leakage. If oil is leaking, immediately turn the engine off and check for the cause.
8. Reset the oil change indicator display according to the following procedure.

To reset the oil change indicator display

1. Push and hold the "TRIP" button for a MAXIMUM of three seconds. While pushing the "TRIP" button, turn the key to "○".

PERIODIC MAINTENANCE AND MINOR REPAIR

2. Release the "TRIP" button and the oil change indicator light will go off.
3. Turn the key to "⌘".

NOTE:

If the engine oil is changed before the oil change indicator light comes on (i.e. before the periodic oil change interval has been reached), the indicator light must be reset after the oil change for the next periodic oil change to be indicated at the correct time. To reset the oil change indicator light before the periodic oil change interval has been reached, follow the above procedure, but note that the indicator light will come on for 1.4 seconds after releasing the reset button, otherwise repeat the procedure.

EAU20061

Final transmission oil

The final transmission case must be checked for oil leakage before each ride. If any leakage is found, have a Yamaha dealer check and repair the scooter. In addition, the final transmission oil must be changed as follows at the intervals specified in the periodic maintenance and lubrication chart.

1. Start the engine, warm up the final transmission oil by riding the scooter for several minutes, and then stop the engine.
2. Place the scooter on the centerstand.
3. Place an oil pan under the final transmission case to collect the used oil.

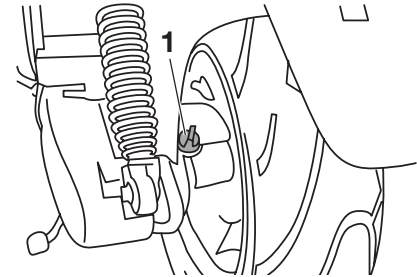

1. Final transmission oil filler cap

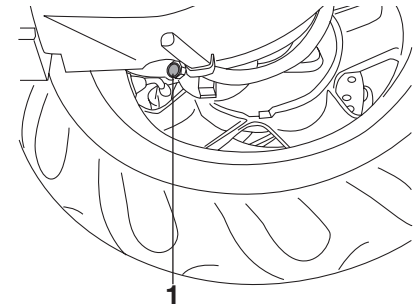

1. Final transmission oil drain bolt

4. Remove the oil filler cap and drain bolt to drain the oil from the final transmission case.
5. Install the final transmission oil drain bolt, and then tighten it to the specified torque.

PERIODIC MAINTENANCE AND MINOR REPAIR

Tightening torque:

Final transmission oil drain bolt:
22 Nm (2.2 m•kgf, 15.9 ft•lbf)

6. Add the specified amount of the recommended final transmission oil, and then install and tighten the oil filler cap.

Recommended final transmission oil:

See page 8-1.

Oil quantity:

0.15 L (0.16 US qt) (0.88 Imp.qt)

EWA11310

WARNING

- Make sure that no foreign material enters the final transmission case.
- Make sure that no oil gets on the tire or wheel.

7. Check the final transmission case for oil leakage. If oil is leaking, check for the cause.

EAU20070

Coolant

The coolant level should be checked before each ride. In addition, the coolant must be changed at the intervals specified in the periodic maintenance and lubrication chart.

EAU20101

To check the coolant level

1. Place the vehicle on the centerstand.

NOTE:

- The coolant level must be checked on a cold engine since the level varies with engine temperature.
- Make sure that the vehicle is positioned straight up when checking the coolant level. A slight tilt to the side can result in a false reading.

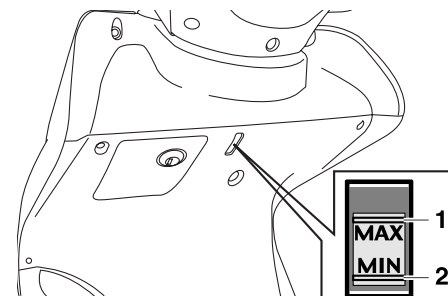

1. Maximum level mark
2. Minimum level mark

2. Check the coolant level in the coolant reservoir.

NOTE:

The coolant should be between the minimum and maximum level marks.

PERIODIC MAINTENANCE AND MINOR REPAIR

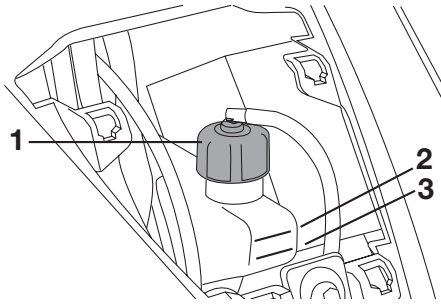

1. Coolant reservoir cap
2. Maximum level mark
3. Minimum level mark

3. If the coolant is at or below the minimum level mark, remove panel A (See page 6-6.), remove the reservoir cap, add coolant to the maximum level mark, and then install the reservoir cap and the panel.

Coolant reservoir capacity (up to the maximum level mark):
0.30 L (0.32 US qt) (0.26 Imp.qt)

ECA10470

CAUTION:

- If coolant is not available, use distilled water or soft tap water instead. Do not use hard water or salt water since it is harmful to the engine.
- If water has been used instead of coolant, replace it with coolant as soon as possible, otherwise the engine may not be sufficiently cooled and the cooling system will not be protected against frost and corrosion.
- If water has been added to the coolant, have a Yamaha dealer check the antifreeze content of the coolant as soon as possible, otherwise the effectiveness of the coolant will be reduced.

EWA10380

⚠ WARNING

Never attempt to remove the radiator cap when the engine is hot.

NOTE:

- The radiator fan is automatically switched on or off according to the coolant temperature in the radiator.
- If the engine overheats, see page 6-33 for further instructions.

EAU33030

Changing the coolant

EWA10380

⚠ WARNING

Never attempt to remove the radiator cap when the engine is hot.

The coolant must be changed at the intervals specified in the periodic maintenance and lubrication chart. Have a Yamaha dealer change the coolant.

PERIODIC MAINTENANCE AND MINOR REPAIR

EAUM1320

Air filter and V-belt case air filter elements

The air filter and the V-belt case air filter elements should be cleaned at the intervals specified in the periodic maintenance and lubrication chart. Clean both filter elements more frequently if you are riding in unusually wet or dusty areas.

Cleaning the air filter element

1. Place the scooter on the centerstand.

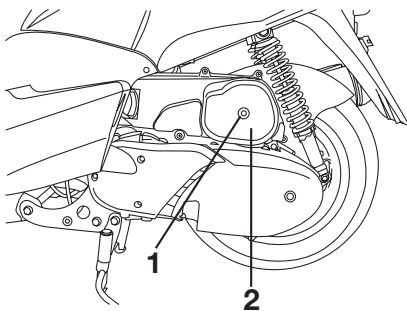

1. Screw
2. Air filter case cover

2. Remove the air filter case cover by removing the screw.

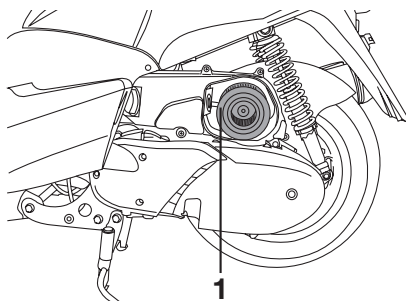

1. Air filter element

3. Pull the air filter element out.

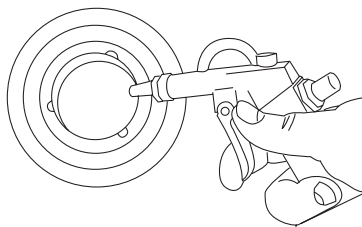

4. Lightly tap the air filter element to remove most of the dust and dirt, and then blow the remaining dirt out with compressed air.
5. Check the air filter element for damage and replace it if necessary.

6. Insert the air filter element into the air filter case.
7. Install the air filter case cover by installing the screw.

Cleaning the V-belt case air filter element

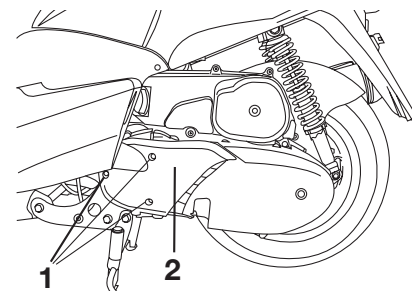

1. Screw
2. V-belt case air filter cover

1. Remove the V-belt case air filter cover by removing the screws.

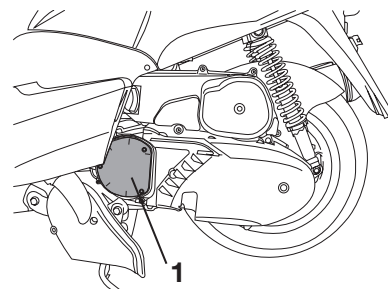

1. Air filter element

PERIODIC MAINTENANCE AND MINOR REPAIR

EAU21300

EAU21370

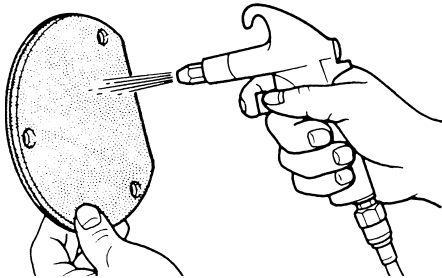

2. Remove the air filter element, and then blow out the dirt with compressed air as shown.
3. Check the air filter element for damage and replace it if necessary.
4. Install the air filter element with the colored side facing outward.
5. Install the V-belt case air filter cover by installing the screws.

ECA10530

CAUTION:

- Make sure that each filter element is properly seated in its case.
- The engine should never be operated without the filter elements installed, otherwise the piston(s) and/or cylinder(s) may become excessively worn.

Adjusting the carburetor

The carburetor is an important part of the engine and requires very sophisticated adjustment. Therefore, all carburetor adjustments should be left to a Yamaha dealer, who has the necessary professional knowledge and experience.

Adjusting the throttle cable free play

The throttle cable free play should measure 4 ~ 6 mm (0.15 ~ 0.24 in) at the throttle grip. Periodically check the throttle cable free play and, if necessary, adjust it as follows.

NOTE:

The engine idling speed must be correctly adjusted before checking and adjusting the throttle cable free play.

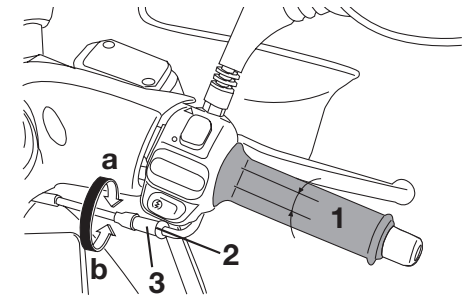

1. Throttle cable free play
 2. Locknut
 3. Adjusting nut
1. Loosen the locknut.
 2. To increase the throttle cable free play, turn the adjusting nut in

PERIODIC MAINTENANCE AND MINOR REPAIR

direction (a). To decrease the throttle cable free play, turn the adjusting nut in direction (b).

3. Tighten the locknut.

EAU21401

Valve clearance

The valve clearance changes with use, resulting in improper air-fuel mixture and/or engine noise. To prevent this from occurring, the valve clearance must be adjusted by a Yamaha dealer at the intervals specified in the periodic maintenance and lubrication chart.

EAU21870

Tires

To maximize the performance, durability, and safe operation of your motorcycle, note the following points regarding the specified tires.

Tire air pressure

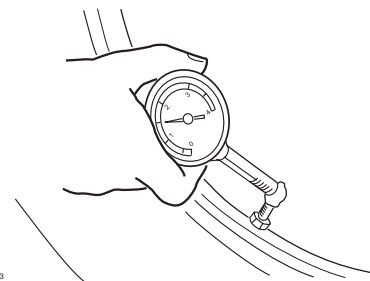

ZALM0053

6

The tire air pressure should be checked and, if necessary, adjusted before each ride.

EWA10500

⚠ WARNING

- The tire air pressure must be checked and adjusted on cold tires (i.e., when the temperature of the tires equals the ambient temperature).

PERIODIC MAINTENANCE AND MINOR REPAIR

- The tire air pressure must be adjusted in accordance with the riding speed and with the total weight of rider, passenger, cargo, and accessories approved for this model.

Tire air pressure (measured on cold tires):

Up to 90 kg (198 lb):

Front:

190 kPa (27 psi) (1.9 kgf/cm²)

Rear:

220 kPa (31 psi) (2.2 kgf/cm²)

90 kg (198 lb) to maximum load:

Front:

190 kPa (27 psi) (1.9 kgf/cm²)

Rear:

240 kPa (34 psi) (2.4 kgf/cm²)

Maximum load*:

177 kg (390.29 lb)

* Total weight of rider, passenger, cargo and accessories

EWA10450

WARNING

Because loading has an enormous impact on the handling, braking, performance and safety characteristics of your vehicle, you should keep the following precautions in mind.

- **NEVER OVERLOAD THE VEHICLE!** Operation of an overloaded vehicle may result in tire damage, loss of control, or severe injury. Make sure that the total weight of rider, cargo, and accessories does not exceed the specified maximum load for the vehicle.
- Do not carry along loosely packed items, which can shift during a ride.
- Securely pack the heaviest items close to the center of the vehicle and distribute the weight evenly on both sides.
- Adjust the suspension and tire air pressure with regard to the load.
- Check the tire condition and air pressure before each ride.

Tire inspection

The tires must be checked before each ride. If the center tread depth reaches the specified limit, if the tire has a nail or glass fragments in it, or if the sidewall is cracked, have a Yamaha dealer replace the tire immediately.

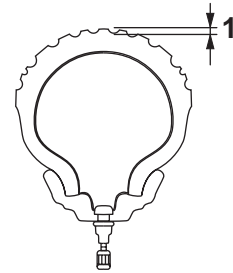

ZAJM0054

1. Tire tread depth

Minimum tire tread depth (front and rear):

1.6 mm (0.06 in)

NOTE:

The tire tread depth limits may differ from country to country. Always comply with the local regulations.

PERIODIC MAINTENANCE AND MINOR REPAIR

EAU21960

Tire information

This motorcycle is equipped with tubeless tires.

Front tire:

Size:

120/70 - 12 51L

Manufacturer/model:

CONTINENTAL / ZIPPY 1

PIRELLI / SL26

MICHELIN / BOPPER

Rear tire:

Size:

130/70 - 12 56L

Manufacturer/model:

CONTINENTAL / ZIPPY 1

PIRELLI / SL26

MICHELIN / BOPPER

a Yamaha dealer, who has the necessary professional knowledge and experience.

Cast wheels

To maximize the performance, durability, and safe operation of your motorcycle, note the following points regarding the specified wheels.

- The wheel rims should be checked for cracks, bends or warpage before each ride. If any damage is found, have a Yamaha dealer replace the wheel. Do not attempt even the smallest repair to the wheel. A deformed or cracked wheel must be replaced.
- The wheel should be balanced whenever either the tire or wheel has been changed or replaced. An unbalanced wheel can result in poor performance, adverse handling characteristics, and a shortened tire life.
- Ride at moderate speeds after changing a tire since the tire surface must first be “broken in” for it to develop its optimal characteristics.

6

EWA10470

WARNING

- **Have a Yamaha dealer replace excessively worn tires. Besides being illegal, operating the vehicle with excessively worn tires decreases riding stability and can lead to loss of control.**
- **The replacement of all wheel and brake related parts, including the tires, should be left to**

PERIODIC MAINTENANCE AND MINOR REPAIR

EAU33453

Front and rear brake lever free play Front

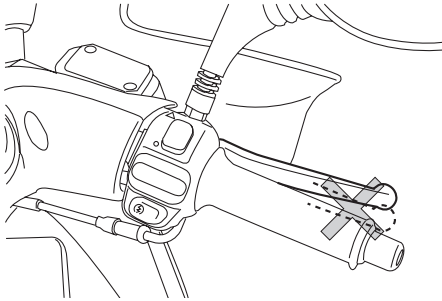

6

Rear

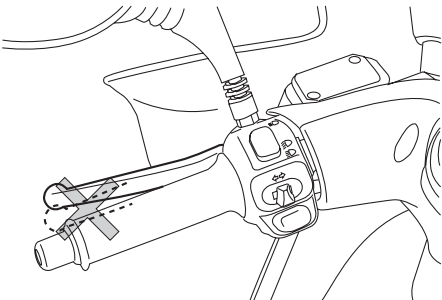

There should be no free play at the brake lever ends. If there is free play, have a Yamaha dealer inspect the brake system.

EWA14211

⚠ WARNING

A soft or spongy feeling in the brake lever can indicate the presence of air in the hydraulic system. If there is air in the hydraulic system, have a Yamaha dealer bleed the system before operating the vehicle. Air in the hydraulic system will diminish the braking performance, which may result in loss of control and an accident.

EAU22390

Checking the front and rear brake pads

The front and rear brake pads must be checked for wear at the intervals specified in the periodic maintenance and lubrication chart.

EAU22430

Front brake pads

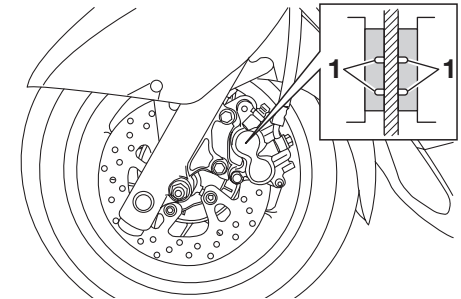

1. Brake pad wear indicator groove

Each front brake pad is provided with wear indicator grooves, which allow you to check the brake pad wear without having to disassemble the brake. To check the brake pad wear, check the wear indicator grooves. If a brake pad has worn to the point that the wear indicator grooves have almost

PERIODIC MAINTENANCE AND MINOR REPAIR

disappeared, have a Yamaha dealer replace the brake pads as a set.

Rear brake pads

EAU22500

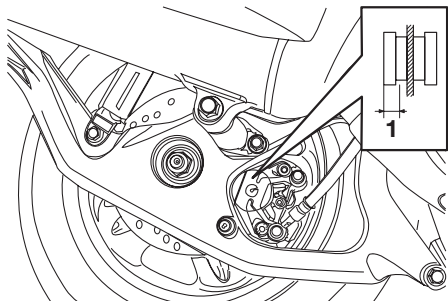

1. Lining thickness

Check each rear brake pad for damage and measure the lining thickness. If a brake pad is damaged or if the lining thickness is less than 3.8 mm (0.15 in), have a Yamaha dealer replace the brake pads as a set.

Checking the brake fluid level

EAU22580

Insufficient brake fluid may allow air to enter the brake system, possibly causing it to become ineffective.

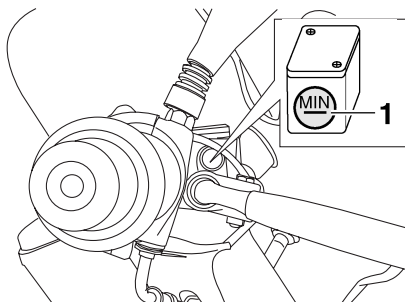

1. Minimum level mark

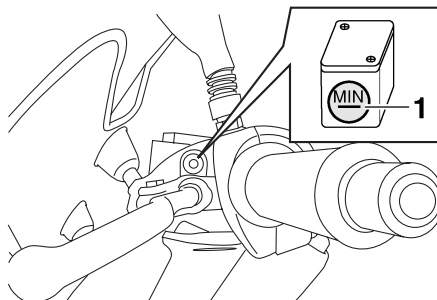

1. Minimum level mark

Before riding, check that the brake fluid is above the minimum level mark and replenish if necessary. A low brake fluid level may indicate worn brake pads and/or brake system leakage. If the brake fluid level is low, be sure to check the brake pads for wear and the brake system for leakage.

Observe these precautions:

- When checking the fluid level, make sure that the top of the brake fluid reservoir is level.
- Use only the recommended quality brake fluid, otherwise the rubber seals may deteriorate, causing leakage and poor braking performance.

Recommended brake fluid:
DOT 4

- Refill with the same type of brake fluid. Mixing fluids may result in a harmful chemical reaction and lead to poor braking performance.
- Be careful that water does not enter the brake fluid reservoir

PERIODIC MAINTENANCE AND MINOR REPAIR

when refilling. Water will significantly lower the boiling point of the fluid and may result in vapor lock.

- Brake fluid may deteriorate painted surfaces or plastic parts. Always clean up spilled fluid immediately.
- As the brake pads wear, it is normal for the brake fluid level to gradually go down. However, if the brake fluid level goes down suddenly, have a Yamaha dealer check the cause.

EAU22720

Changing the brake fluid

Have a Yamaha dealer change the brake fluid at the intervals specified in the NOTE after the periodic maintenance and lubrication chart. In addition, have the oil seals of the brake master cylinder and caliper as well as the brake hose replaced at the intervals listed below or whenever they are damaged or leaking.

- Oil seals: Replace every two years.
- Brake hose: Replace every four years.

EAU23100

Checking and lubricating the cables

The operation of all control cables and the condition of the cables should be checked before each ride, and the cables and cable ends should be lubricated if necessary. If a cable is damaged or does not move smoothly, have a Yamaha dealer check or replace it.

Recommended lubricant:
Engine oil

EWA10720

WARNING

Damage to the outer sheath may interfere with proper cable operation and will cause the inner cable to rust. Replace a damaged cable as soon as possible to prevent unsafe conditions.

PERIODIC MAINTENANCE AND MINOR REPAIR

Lubricating the front and rear brake levers

EAU23170

The pivoting points of the front and rear brake levers must be lubricated at the intervals specified in the periodic maintenance and lubrication chart.

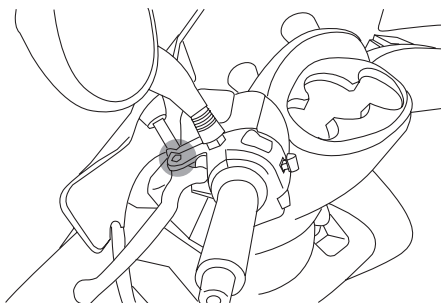
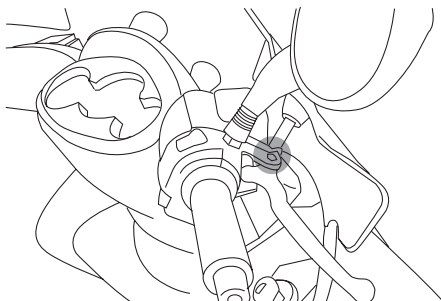

Recommended lubricant:

Lithium-soap-based grease (all-purpose grease)

Checking and lubricating the centerstand and sidestand

EAU23211

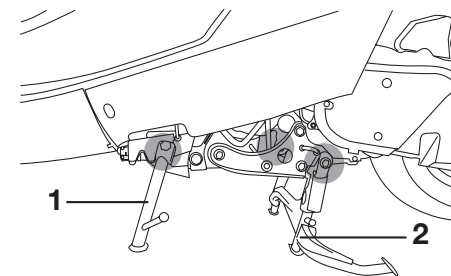

1. Sidestand
2. Centerstand

The operation of the centerstand and sidestand should be checked before each ride, and the pivots and metal-to-metal contact surfaces should be lubricated if necessary.

EWA10740

⚠ WARNING

If the centerstand or sidestand does not move up and down smoothly, have a Yamaha dealer check or repair it.

Recommended lubricant:

Lithium-soap-based grease (all-purpose grease)

PERIODIC MAINTENANCE AND MINOR REPAIR

EAU23271

Checking the front fork

The condition and operation of the front fork must be checked as follows at the intervals specified in the periodic maintenance and lubrication chart.

To check the condition

EWA10750

⚠ WARNING

Securely support the motorcycle so that there is no danger of it falling over.

Check the inner tubes for scratches, damage and excessive oil leakage.

To check the operation

1. Place the motorcycle on a level surface and hold it in an upright position.

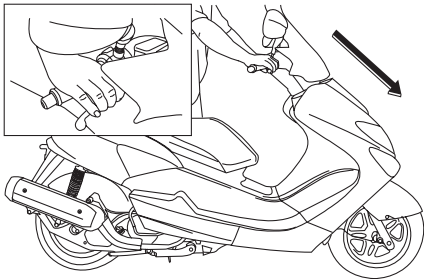

2. While applying the front brake, push down hard on the handlebars several times to check if the front fork compresses and rebounds smoothly.

ECA10590

CAUTION:

If any damage is found or the front fork does not operate smoothly, have a Yamaha dealer check or repair it.

EAU23280

Checking the steering

Worn or loose steering bearings may cause danger. Therefore, the operation of the steering must be checked as follows at the intervals specified in the periodic maintenance and lubrication chart.

1. Place a stand under the engine to raise the front wheel off the ground.

EWA10750

⚠ WARNING

Securely support the motorcycle so that there is no danger of it falling over.

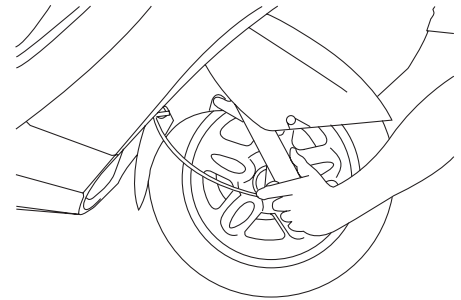

2. Hold the lower ends of the front fork legs and try to move them forward and backward. If any free

PERIODIC MAINTENANCE AND MINOR REPAIR

play can be felt, have a Yamaha dealer check or repair the steering.

EAU23290

EAUM1401

Checking the wheel bearings

The front and rear wheel bearings must be checked at the intervals specified in the periodic maintenance and lubrication chart. If there is play in the wheel hub or if the wheel does not turn smoothly, have a Yamaha dealer check the wheel bearings.

Battery

A poorly maintained battery will corrode and discharge quickly. The electrolyte level, battery lead connections and breather hose routing should be checked before each ride and at the intervals specified in the periodic maintenance and lubrication chart.

To check the electrolyte level

1. Place the scooter on a level surface and hold it in an upright position.

NOTE: _____

Make sure that the scooter is positioned straight up when checking the electrolyte level.

2. Remove panel B. (See page 6-6.)

PERIODIC MAINTENANCE AND MINOR REPAIR

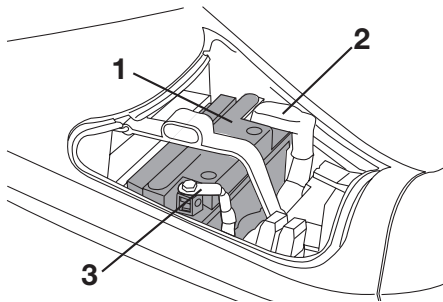

1. Battery
2. Positive battery terminal
3. Negative battery terminal

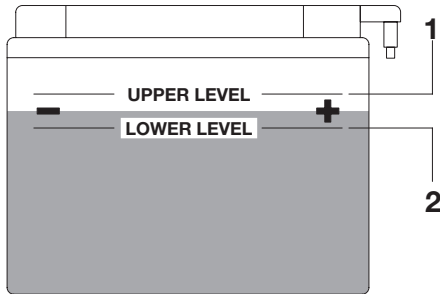

1. Maximum level mark
2. Minimum level mark
3. Check the electrolyte level in the battery.

NOTE: _____
The electrolyte should be between the minimum and maximum level marks.

4. If the electrolyte is at or below the minimum level mark, add distilled water to raise it to the maximum level mark.

EWA10760

⚠ WARNING

- **Electrolyte is poisonous and dangerous since it contains sulfuric acid, which causes severe burns. Avoid any contact with skin, eyes or clothing and always shield your eyes when working near batteries. In case of contact, administer the following FIRST AID.**
 - **EXTERNAL:** Flush with plenty of water.
 - **INTERNAL:** Drink large quantities of water or milk and immediately call a physician.
 - **EYES:** Flush with water for 15 minutes and seek prompt medical attention.

- **Batteries produce explosive hydrogen gas. Therefore, keep sparks, flames, cigarettes, etc., away from the battery and provide sufficient ventilation when charging it in an enclosed space.**
- **KEEP THIS AND ALL BATTERIES OUT OF THE REACH OF CHILDREN.**

ECA10610

CAUTION: _____

Use only distilled water, as tap water contains minerals that are harmful to the battery.

5. Check and, if necessary, tighten the battery lead connections and correct the breather hose routing.

To store the battery

1. If the scooter will not be used for more than one month, remove the battery, fully charge it, and then place it in a cool, dry place.

PERIODIC MAINTENANCE AND MINOR REPAIR

2. If the battery will be stored for more than two months, check the specific gravity of the electrolyte at least once a month and fully charge the battery whenever necessary.
3. Fully charge the battery before installation.
4. After installation, make sure that the battery leads are properly connected to the battery terminals and that the breather hose is properly routed, in good condition, and not obstructed.

ECA10600

CAUTION:

If the breather hose is positioned in such a way that the frame is exposed to electrolyte or gas expelled from the battery, the frame could suffer structural and external damages.

Replacing the fuses

The main fuse box and the fuse box, which contains the fuses for the individual circuits, are located under panel B. (See page 6-6.)

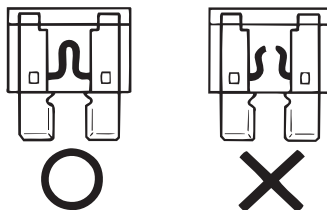

If a fuse is blown, replace it as follows.

1. Turn the key to “ \otimes ” and turn off the electrical circuit in question.

EAU23630

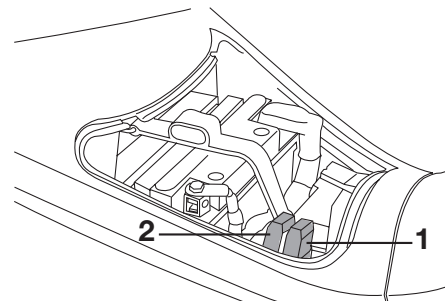

1. Main fuse
2. Radiator fan fuse

2. Remove the blown fuse, and then install a new fuse of the specified amperage.

Specified fuses:

Main fuse:
20 A
Radiator fan fuse:
4 A

CAUTION:

Do not use a fuse of a higher amperage rating than recommended to avoid causing extensive damage to the electrical system and possibly a fire.

ECA10640

PERIODIC MAINTENANCE AND MINOR REPAIR

EAUS1370

3. Turn the key to “○” and turn on the electrical circuit in question to check if the device operates.
4. If the fuse immediately blows again, have a Yamaha dealer check the electrical system.

Replacing a headlight bulb

This model is equipped with quartz bulb headlights. If a headlight bulb burns out, replace it as follows.

To replace the low beam headlight bulb

1. Remove panel A. (See page 6-6.)

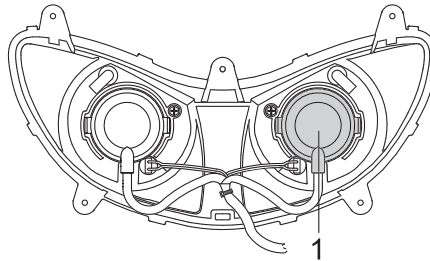

1. Headlight bulb cover
2. Remove the bulb cover.

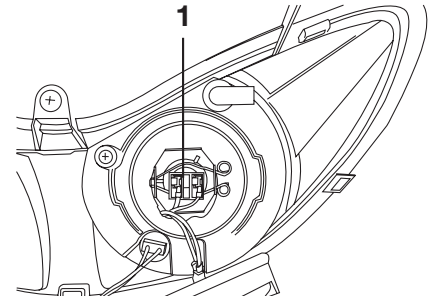

1. Headlight coupler
3. Disconnect the headlight coupler.

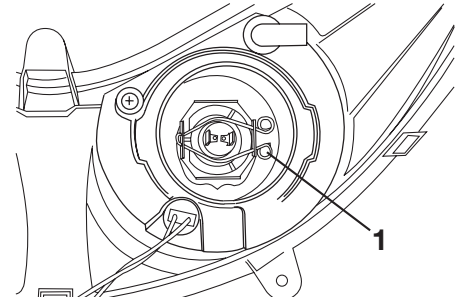

1. Headlight bulb holder
- 4 Unhook the headlight bulb holder, and then remove the defective bulb.

PERIODIC MAINTENANCE AND MINOR REPAIR

WARNING

EWA10790

Headlight bulbs get very hot. Therefore, keep flammable products away from a lit headlight bulb, and do not touch the bulb until it has cooled down.

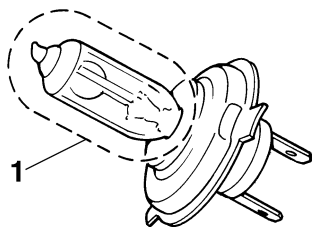

1. Do not touch the glass part of the bulb

5. Place a new headlight bulb into position, and then secure it with the bulb holder.

CAUTION:

ECA10650

Take care not to damage the following parts:

● Headlight bulb

Do not touch the glass part of the headlight bulb to keep it free from oil, otherwise the

transparency of the glass, the luminosity of the bulb, and the bulb life will be adversely affected. Thoroughly clean off any dirt and fingerprints on the headlight bulb using a cloth moistened with alcohol or thinner.

● Headlight lens

- Do not affix any type of tinted film or stickers to the headlight lens.
- Do not use a headlight bulb of a wattage higher than specified.

6. Connect the headlight coupler.
7. Install the headlight bulb cover.
8. Install the panel.
9. Have a Yamaha dealer adjust the headlight beam if necessary.

To replace the high beam headlight bulb

1. Remove panel A. (See page 6-6.)

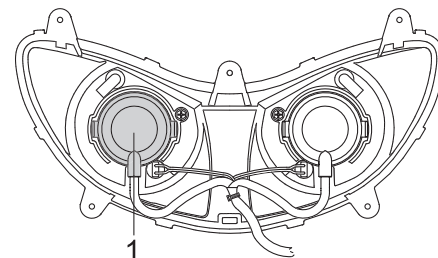

1. Headlight bulb cover

2. Remove the bulb cover.

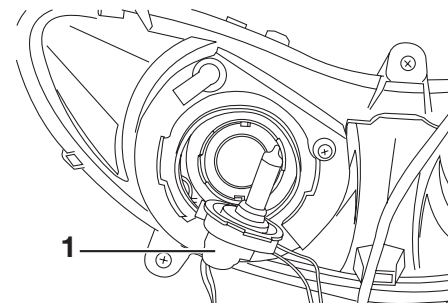

1. Headlight bulb holder

3. Unhook the headlight bulb holder by turning it counterclockwise, and then remove the defective bulb

PERIODIC MAINTENANCE AND MINOR REPAIR

⚠ WARNING

EWA10790

Headlight bulbs get very hot. Therefore, keep flammable products away from a lit headlight bulb, and do not touch the bulb until it has cooled down.

- Place a new headlight bulb into position, and then secure it with the bulb holder by turning it clockwise

ECA10650

CAUTION:

Take care not to damage the following parts:

- **Headlight bulb**
Do not touch the glass part of the headlight bulb to keep it free from oil, otherwise the transparency of the glass, the luminosity of the bulb, and the bulb life will be adversely affected. Thoroughly clean off any dirt and fingerprints on the headlight bulb using a cloth moistened with alcohol or thinner.
- **Headlight lens**

- Do not affix any type of tinted film or stickers to the headlight lens.
- Do not use a headlight bulb of a wattage higher than specified.

- Install the headlight bulb cover
- Install the panel.
- Have a Yamaha dealer adjust the headlight beam if necessary.

EAU24250

Replacing a front turn signal light bulb

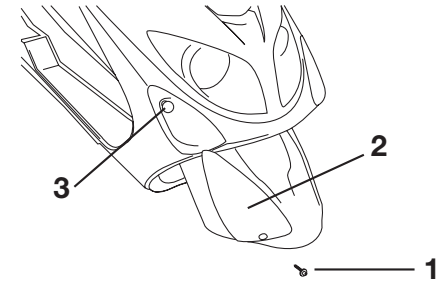

- Screw
- Front turn signal light lens
- Light bulb

- Remove the front turn signal light lens by removing the screw.
- Remove the defective bulb by pushing it in and turning it counterclockwise.
- Insert a new bulb into the socket, push it in, and then turn it clockwise until it stops.
- Install the lens by installing the screw.

ECA11190

CAUTION:

Do not overtighten the screw, otherwise the lens may break.

PERIODIC MAINTENANCE AND MINOR REPAIR

Replacing the tail/brake light bulb or a rear turn signal light bulb

EAUS1130

Tail/brake light bulb

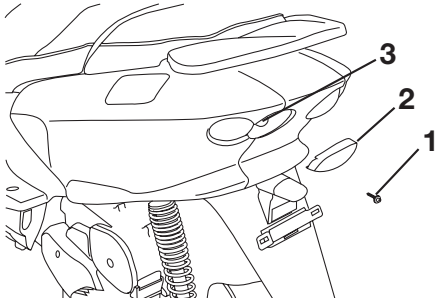

1. Screw
2. Tail/brake light lens
3. Bulb

1. Remove the tail/brake light lens by removing the screw.
2. Remove the defective bulb by pushing it in and turning it counterclockwise.
3. Insert a new bulb into the socket, push it in, and then turn it clockwise until it stops.
4. Install the lens by installing the screw.

Rear turn signal light bulb

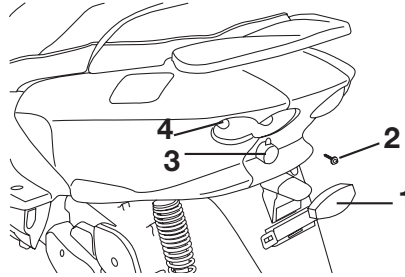

1. Turn signal light lens
2. Screw
3. Turn signal light bulb lens
4. Bulb

1. Remove the tail/brake light bulb lens by removing the screw.
2. Remove the left or right turn signal light bulb lens by pulling it backwards.
3. Remove the bulb cap by removing the screw.
4. Remove the defective bulb by pushing it in and turning it counterclockwise.
5. Insert a new bulb into the socket, push it in, and then turn it clockwise until it stops.
6. Install the bulb cap by installing the screw

7. Install the turn signal light bulb lens.
8. Install the tail/brake light bulb lens by installing the screw.

ECA10680

CAUTION:

Do not overtighten the screws, otherwise the lens may break.

PERIODIC MAINTENANCE AND MINOR REPAIR

EAUM1460

Replacing the license plate light bulb

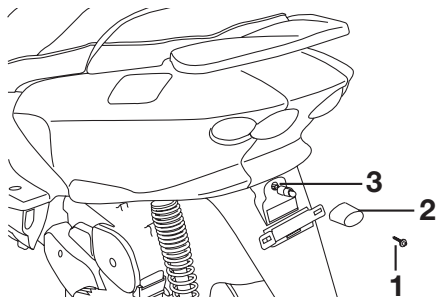

1. Screw
2. License plate light cover
3. Socket

1. Remove the license plate light cover by removing the screw.
2. Remove the socket (together with the bulb) by pulling it out.
3. Remove the defective bulb by pulling it out.
4. Insert a new bulb into the socket.
5. Install the socket (together with the bulb) by pushing it in.
6. Install the license plate light cover by installing the screw.

EAUS1260

Replacing the auxiliary light bulb

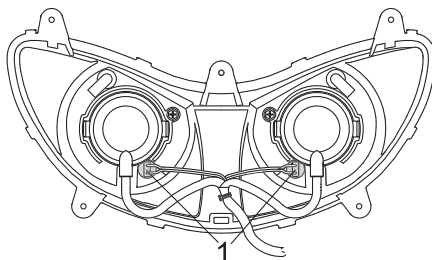

1. Auxiliary light bulb socket

If the auxiliary light bulb burns out, replace it as follows.

1. Remove panel A . (See page 6-6.).
2. Remove the socket (together with the bulb) by pulling it out.
3. Remove the defective bulb by pulling it out.
4. Insert a new bulb into the socket.
5. Install the socket (together with the bulb) by pushing it in.
6. Install the panel A.

EAU25880

Troubleshooting

Although Yamaha scooters receive a thorough inspection before shipment from the factory, trouble may occur during operation. Any problem in the fuel, compression, or ignition systems, for example, can cause poor starting and loss of power.

The following troubleshooting charts represent quick and easy procedures for checking these vital systems yourself. However, should your scooter require any repair, take it to a Yamaha dealer, whose skilled technicians have the necessary tools, experience, and know-how to service the scooter properly.

Use only genuine Yamaha replacement parts. Imitation parts may look like Yamaha parts, but they are often inferior, have a shorter service life and can lead to expensive repair bills.

PERIODIC MAINTENANCE AND MINOR REPAIR

EAU25941

Troubleshooting charts

Starting problems or poor engine performance

EWA10840



WARNING

Keep away from open flames and do not smoke while checking or working on the fuel system.

1. Fuel

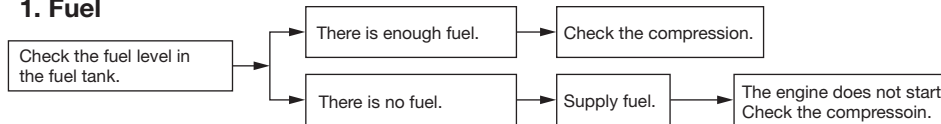

2. Compression

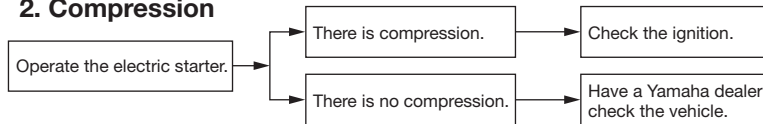

3. Ignition

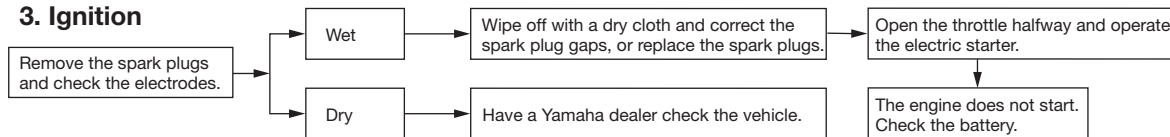

4. Battery

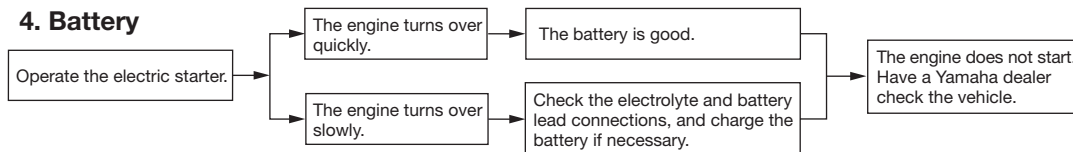

PERIODIC MAINTENANCE AND MINOR REPAIR

Engine overheating

EWA10400

⚠ WARNING

- Do not remove the radiator cap when the engine and radiator are hot. Scalding hot fluid and steam may be blown out under pressure, which could cause serious injury. Be sure to wait until the engine has cooled.
- After removing the radiator cap retaining bolt, place a thick rag, like a towel, over the radiator cap, and then slowly rotate the cap counterclockwise to the detent to allow any residual pressure to escape. When the hissing sound has stopped, press down on the cap while turning it counterclockwise, and then remove the cap.

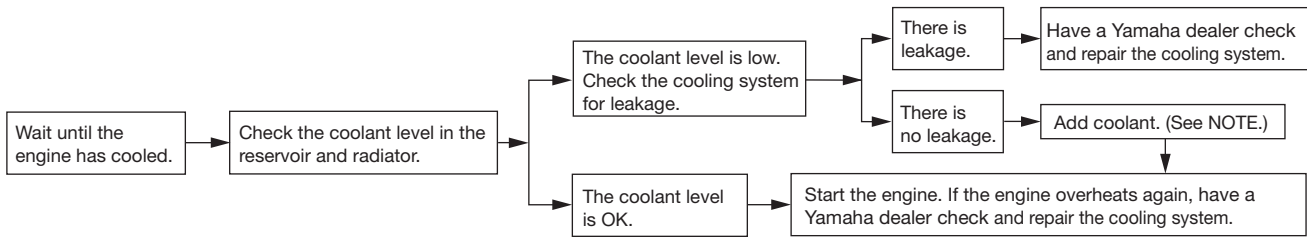

NOTE:

If coolant is not available, tap water can be temporarily used instead, provided that it is changed to the recommended coolant as soon as possible.

SCOOTER CARE AND STORAGE

EAU37832

EAU26090

Matte color caution

CAUTION:

Some models are equipped with matte colored finished parts. Be sure to consult a Yamaha dealer for advice on what products to use before cleaning the vehicle. Using a brush, harsh chemical products or cleaning compounds when cleaning these parts will scratch or damage their surface. Wax also should not be applied to any matte colored finished parts.

ECA15192

Care

While the open design of a scooter reveals the attractiveness of the technology, it also makes it more vulnerable. Rust and corrosion can develop even if high-quality components are used. A rusty exhaust pipe may go unnoticed on a car, however, it detracts from the overall appearance of a scooter. Frequent and proper care does not only comply with the terms of the warranty, but it will also keep your scooter looking good, extend its life and optimize its performance.

Before cleaning

1. Cover the muffler outlet with a plastic bag after the engine has cooled down.
2. Make sure that all caps and covers as well as all electrical couplers and connectors, including the spark plug cap, are tightly installed.
3. Remove extremely stubborn dirt, like oil burnt onto the crankcase, with a degreasing agent and a brush, but never apply such pro-

ducts onto seals, gaskets and wheel axles. Always rinse the dirt and degreaser off with water.

Cleaning

ECA10780

CAUTION:

- Avoid using strong acidic wheel cleaners, especially on spoked wheels. If such products are used on hard-to-remove dirt, do not leave the cleaner on the affected area any longer than instructed. Also, thoroughly rinse the area off with water, immediately dry it, and then apply a corrosion protection spray.
- Improper cleaning can damage windshields, cowlings, panels and other plastic parts. Use only a soft, clean cloth or sponge with mild detergent and water to clean plastic.
- Do not use any harsh chemical products on plastic parts. Be sure to avoid using cloths or sponges which have been in contact with strong or abrasive cleaning products, solvent or

SCOOTER CARE AND STORAGE

ECA10790

thinner, fuel (gasoline), rust removers or inhibitors, brake fluid, antifreeze or electrolyte.

- **Do not use high-pressure washers or steam-jet cleaners since they cause water seepage and deterioration in the following areas: seals (of wheel and swingarm bearings, fork and brakes), electric components (couplers, connectors, instruments, switches and lights), breather hoses and vents.**
 - **For scooters equipped with a windshield: Do not use strong cleaners or hard sponges as they will cause dulling or scratching. Some cleaning compounds for plastic may leave scratches on the windshield. Test the product on a small hidden part of the windshield to make sure that it does not leave any marks. If the windshield is scratched, use a quality plastic polishing compound after washing.**
-

After normal use

Remove dirt with warm water, a mild detergent, and a soft, clean sponge, and then rinse thoroughly with clean water. Use a toothbrush or bottle-brush for hard-to-reach areas. Stubborn dirt and insects will come off more easily if the area is covered with a wet cloth for a few minutes before cleaning.

After riding in the rain, near the sea or on salt-sprayed roads

Since sea salt or salt sprayed on the roads during winter are extremely corrosive in combination with water, carry out the following steps after each ride in the rain, near the sea or on salt-sprayed roads.

NOTE: _____

Salt sprayed on roads in the winter may remain well into spring.

1. Clean the scooter with cold water and a mild detergent after the engine has cooled down.

CAUTION: _____

Do not use warm water since it increases the corrosive action of the salt.

2. Apply a corrosion protection spray on all metal, including chrome- and nickel-plated, surfaces to prevent corrosion.

After cleaning

1. Dry the scooter with a chamois or an absorbing cloth.
2. Use a chrome polish to shine chrome, aluminum and stainless-steel parts, including the exhaust system. (Even the thermally induced discoloring of stainless-steel exhaust systems can be removed through polishing.)
3. To prevent corrosion, it is recommended to apply a corrosion protection spray on all metal, including chrome- and nickel-plated, surfaces.
4. Use spray oil as a universal cleaner to remove any remaining dirt.
5. Touch up minor paint damage caused by stones, etc.

SCOOTER CARE AND STORAGE

EAU26300

6. Wax all painted surfaces.
7. Let the scooter dry completely before storing or covering it.

EWA10940

WARNING

- **Make sure that there is no oil or wax on the brakes or tires. If necessary, clean the brake discs and brake linings with a regular brake disc cleaner or acetone, and wash the tires with warm water and a mild detergent.**
- **Before operating the scooter test its braking performance and cornering behavior.**

ECA10800

CAUTION:

- **Apply spray oil and wax sparingly and make sure to wipe off any excess.**
- **Never apply oil or wax to any rubber and plastic parts, but treat them with a suitable care product.**
- **Avoid using abrasive polishing compounds as they will wear away the paint.**

NOTE: _____
Consult a Yamaha dealer for advice on what products to use.

Storage **Short-term**

Always store your scooter in a cool, dry place and, if necessary, protect it against dust with a porous cover.

ECA10820

CAUTION:

- **Storing the scooter in a poorly ventilated room or covering it with a tarp, while it is still wet, will allow water and humidity to seep in and cause rust.**
- **To prevent corrosion, avoid damp cellars, stables (because of the presence of ammonia) and areas where strong chemicals are stored.**

Long-term

Before storing your scooter for several months:

1. Follow all the instructions in the “Care” section of this chapter.
2. Drain the carburetor float chamber by loosening the drain bolt; this will prevent fuel deposits from building up. Pour the drained fuel into the fuel tank.

SCOOTER CARE AND STORAGE

EWA10950

WARNING

To prevent damage or injury from sparking, make sure to ground the spark plug electrodes while turning the engine over.

3. Fill up the fuel tank and add fuel stabilizer (if available) to prevent the fuel tank from rusting and the fuel from deteriorating.
4. Perform the following steps to protect the cylinder, piston rings, etc. from corrosion.
 - a. Remove the spark plug cap and spark plug.
 - b. Pour a teaspoonful of engine oil into the spark plug bore.
 - c. Install the spark plug cap onto the spark plug, and then place the spark plug on the cylinder head so that the electrodes are grounded. (This will limit sparking during the next step.)
 - d. Turn the engine over several times with the starter. (This will coat the cylinder wall with oil.)
 - e. Remove the spark plug cap from the spark plug, and then install the spark plug and the spark plug cap.

5. Lubricate all control cables and the pivoting points of all levers and pedals as well as of the sidestand/centerstand.
6. Check and, if necessary, correct the tire air pressure, and then lift the scooter so that both of its wheels are off the ground. Alternatively, turn the wheels a little every month in order to prevent the tires from becoming degraded in one spot.
7. Cover the muffler outlet with a plastic bag to prevent moisture from entering it.
8. Remove the battery and fully charge it. Store it in a cool, dry place and charge it once a month. Do not store the battery in an excessively cold or warm place [less than 0 °C (30 °F) or more than 30 °C (90 °F)]. For more

information on storing the battery, see page 6-24.

NOTE: _____
Make any necessary repairs before storing the scooter.

Dimensions

- Overall length
2030 mm (79.9 in)
- Overall width
745 mm (29.3 in)
- Overall height
1285 mm (50.6 in)
- Seat height
774 mm (30.5 in)
- Wheelbase
1480 mm (58.2 in)
- Ground clearance
102 mm (4.01 in)
- Minimum turning radius
3840 mm (151.2 in)

Weight

- With oil and fuel
148 kg (326 lb)

Engine

- Engine type
Liquid cooled 4-stroke, SOHC
- Cylinder arrangement
Forward-inclined single cylinder
- Displacement
124.1 cm³ (7.57 cu.in)
- Bore x stroke
53.7 x 54.8 mm (2.11 x 2.15 in)
- Compression ratio
11:1
- Starting system
Electric starter
- Lubrication system
Wet sump

Engine oil

- Type
SAE10W30 or SAE10W40

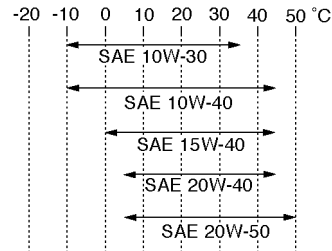

- Recommended engine oil grade
API service SE, SF, SG type or higher

Engine oil quantity

- Periodic oil change
1.2 L (1.27 US qt) (1.06 Imp.qt)

Final transmission oil

- Type
YAMALUBE 4 (10W30) of SAE10W30 type SE motorolie
- Quantity
0.15 L (0.16 US qt) (0.88 Imp.qt)

Cooling system

- Radiator capacity (including all routes)
1.20 L (1.27 US qt) (1.06 Imp.qt)
- Coolant reservoir capacity (up to the maximum level mark)
0.30 L (0.32 US qt) (0.26 Imp.qt)

Air filter

- Air filter element
Dry element

Recommended fuel

- Recommended fuel
Unleaded fuel
- Fuel tank capacity
10.5 L (2.77US gal) (2.31 Imp.gal)
- Fuel reserve amount
3 L (0.79 US gal) (0.66 Imp gal)

Carburetor

- Manufacturer
TEIKEI
- Type x quantity
TK28 x 1

Spark plug (s)

- Manufacturer/model
NGK / CR8E
- Spark plug gap
0.7 - 0.8 (0.028 - 0.031 in)

Clutch

- Clutch type
Dry, automatic centrifugal

Transmission

- Primary reduction system
Helical gear
- Primary reduction ratio
40/15 (2.666)
- Secondary reduction system
Helical gear
- Secondary reduction ratio
40/15 (2.666)
- Transmission type
V-belt automatic

SPECIFICATIONS

Operation

Centrifugal automatic type

Chassis

Frame type

Steel tube underbone

Caster angle

28 °

Trail

104.0 mm (4.09 in)

Front tire

Type

Tubeless

Size

120/70 - 12 51L

Manufacturer/model

CONTINENTAL / ZIPPY 1

PIRELLI / SL26

MICHELIN / BOPPER

Rear tire

Type

Tubeless

Size

130/70 - 12 56L

Manufacturer/model

CONTINENTAL / ZIPPY 1

PIRELLI / SL26

MICHELIN / BOPPER

Loading

Maximum load

177 kg (390.29 lb)

Load is total weight of the equipment, driver, passenger and accessories

Tire air pressure (measured on cold tires)

Loading condition

0–90 kg (0–198 lb)

Front

190 kPa (27 psi) (1.9 kgf/cm²)

Rear

220 kPa (31 psi) (2.2 kgf/cm²)

Loading condition

90 kg (198 lb)–Maximum load

Front

190 kPa (27 psi) (1.9 kgf/cm²)

Rear

240 kPa (34 psi) (2.4 kgf/cm²)

Front wheel

Wheel type

Aluminium wheel

Rim size

12 x MT3.50

Rear wheel

Wheel type

Aluminium wheel

Rim size

12 x MT3.50

Front brake

Type

Single disc brake

Operation

Right hand operation

Recommended fluid

DOT 4

Rear brake

Type

Single disc brake

Operation

Left hand operation

Recommended fluid

DOT 4

Front suspension

Type

Telescopic fork

Spring/shock absorber type

Coil spring/oil damper

Wheel travel

90 mm (3.54 in)

Rear suspension

Type

Unit swing

Spring/shock absorber type

Coil spring/oil damper

Wheel travel

90 mm (3.54 in)

Electrical system

Ignition system

CDI

Charging system

AC magneto

Battery

Manufacturer/model

GS / CB7L-B2

Voltage, capacity

12 V, 8.0 Ah

Bulb voltage, wattage x quantity

Headlight

12 V, 55.0 W x 2

Auxiliary light

12 V, 5.0 W x 2

Tail/brake light

12 V, 21.0 W / 5.0 W x 2

Front turn signal light

12 V, 21.0 W x 2

Rear turn signal light

12 V, 10.0 W x 2

License plate light

12 V, 5.0 W x 1

Meter lighting

12 V, 1.2 W x 2

High beam Indicator light

12 V, 1.2 W x 1

Turn signal indicator light

12 V, 1.2 W x 2

Coolant temperature warning light

12 V, 1.2 W x 1

Fuses

Main fuse

20 A

Radiator fan fuse

4 A

Reserve fuse

20 A

Reserve fuse

4 A

CONSUMER INFORMATION

EAU26351

Identification numbers

Record the key identification number, vehicle identification number and model label information in the spaces provided below for assistance when ordering spare parts from a Yamaha dealer or for reference in case the vehicle is stolen.

KEY IDENTIFICATION NUMBER:

VEHICLE IDENTIFICATION NUMBER:

MODEL LABEL INFORMATION:

Key identification number

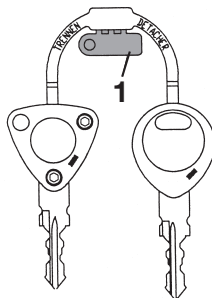

1. Key identification number

The key identification number is stamped into the key tag. Record this number in the space provided and use it for reference when ordering a new key.

EAU26381

Vehicle identification number

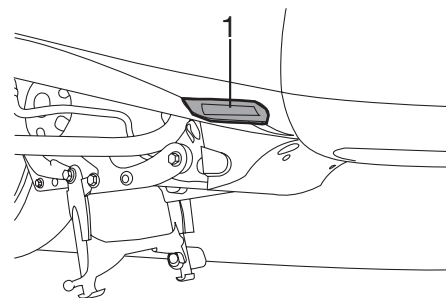

1. Vehicle identification number

The vehicle identification number is stamped into the frame.

NOTE: _____

The vehicle identification number is used to identify your motorcycle and may be used to register your motorcycle with the licensing authority in your area.

EAU26410

EAU26490

Model label

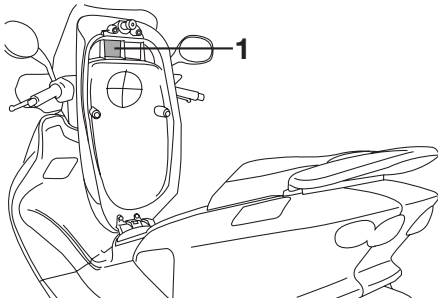

1. Model label

The model label is affixed to the bottom of the seat. (See page 3-9.) Record the information on this label in the space provided. This information will be needed when ordering spare parts from a Yamaha dealer.

INDEX

A

- Acceleration and deceleration5-2
- Air filter and V-belt case air filter elements6-14
- Anti-theft alarm (optional)3-5
- Auxiliary light bulb, replacing.....6-31

B

- Battery.....6-24
- Brake fluid level, checking6-20
- Brake fluid, changing6-21
- Brake lever, front.....3-6
- Brake lever, rear3-6
- Brake levers, lubricating6-22
- Braking.....5-2

C

- Cables, checking and lubricating6-21
- Carburetor,adjusting.....6-15
- Care.....7-1
- Catalytic converter.....3-9
- Caution, matte color7-1
- Centerstand and sidestand, checking and lubricating6-22
- Clock.....3-4
- Coolant.....6-12
- Coolant temperature warning light3-2

D

- Dimmer switch3-5

E

- Engine break-in5-3
- Engine oil6-9

F

- Final transmission oil6-11
- Front and rear brake lever free play.....6-19
- Front and rear brake pads, checking6-19

- Front fork, checking6-23
- Front Storage compartment3-10
- Fuel3-8
- Fuel consumption, tips for reducing.....5-3
- Fuel tank breather/overflow hose3-9
- Fuel tank cap3-7
- Fuses, replacing.....6-26

H

- Handlebar switches3-5
- Hazard switch3-6
- Headlight bulb, replacing6-27
- High beam indicator light.....3-2
- Horn switch.....3-5

I

- Identification numbers9-1
- Ignition circuit cut-off system3-13
- Indicator lights3-2

K

- Key identification number9-1

L

- License plate light bulb, replacing6-31

M

- Main switch/steering lock3-1
- Model label9-2

O

- Oil change indicator.....3-2

P

- Panels, removing and installing6-6
- Parking5-4
- Part locations2-1
- Periodic maintenance and lubrication chart.....6-3
- Pre-operation check list.....4-2

S

- Safe-riding points.....1-4
- Safety information.....1-1
- Seat.....3-9
- Shock absorber assemblies, adjusting....3-12
- Sidestand3-12
- Spark plug, checking6-7
- Specifications.....8-1
- Speedometer unit3-2
- Start switch.....3-5
- Starting a cold engine.....5-1
- Starting off5-2
- Steering, checking6-23
- Storage.....7-3
- Storage compartment.....3-11

T

- Tail/brake light bulb or rear turn signal light bulb, replacing6-30
- Throttle cable free play, adjusting.....6-15
- Tires6-16
- Tool kit.....6-1
- Troubleshooting6-31
- Troubleshooting charts6-32
- Turn signal indicator lights3-2
- Turn signal light bulb (front), replacing6-29
- Turn signal switch3-5

V

- Valve clearance.....6-16
- Vehicle identification number.....9-1

W

- Wheel bearings, checking.....6-24
- Wheels6-18



PRINTED IN NEEDEERLAND
2006.09
(E)